

bed

Product ID. QU2NY



Scan for Support
support@garvee.com



Distributed by
GARVEE.com

Installation Manual

Product ID. QU2NY



Scan for Support

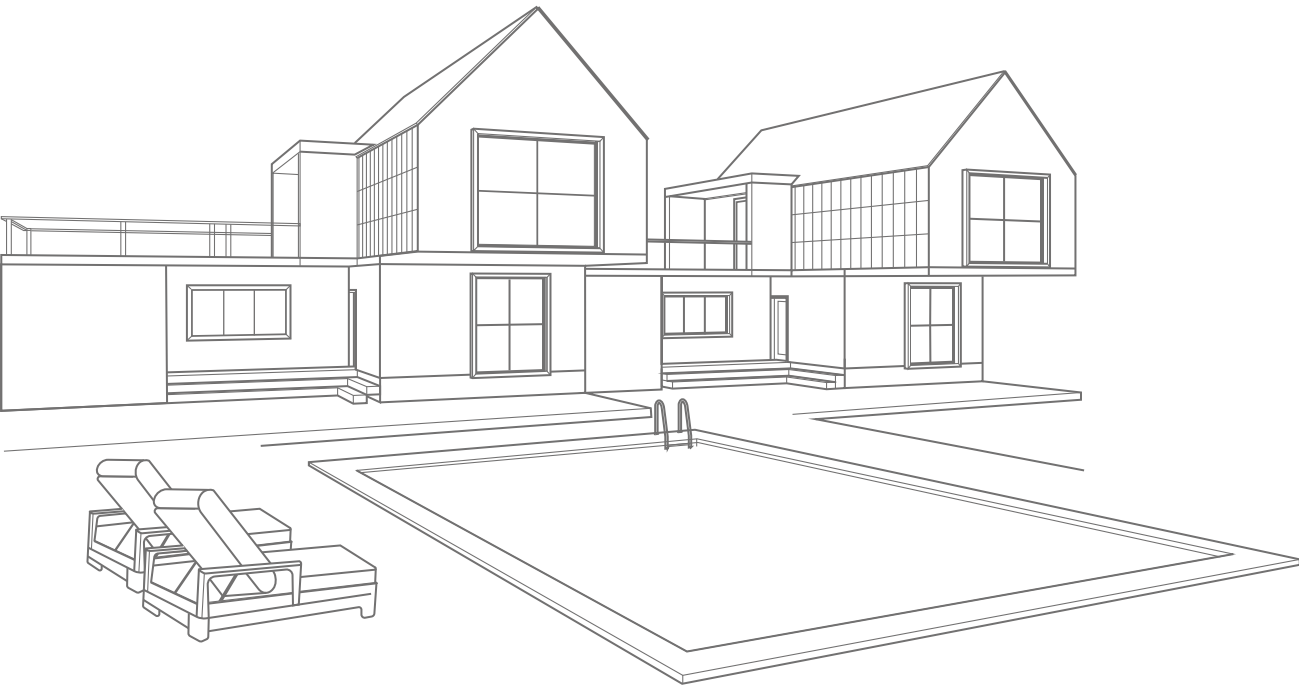

Distributed by
GARVEE.com

support@garvee.com

SPU : PHK-33TRUHS7

Lot NO : TC-NO.1

King

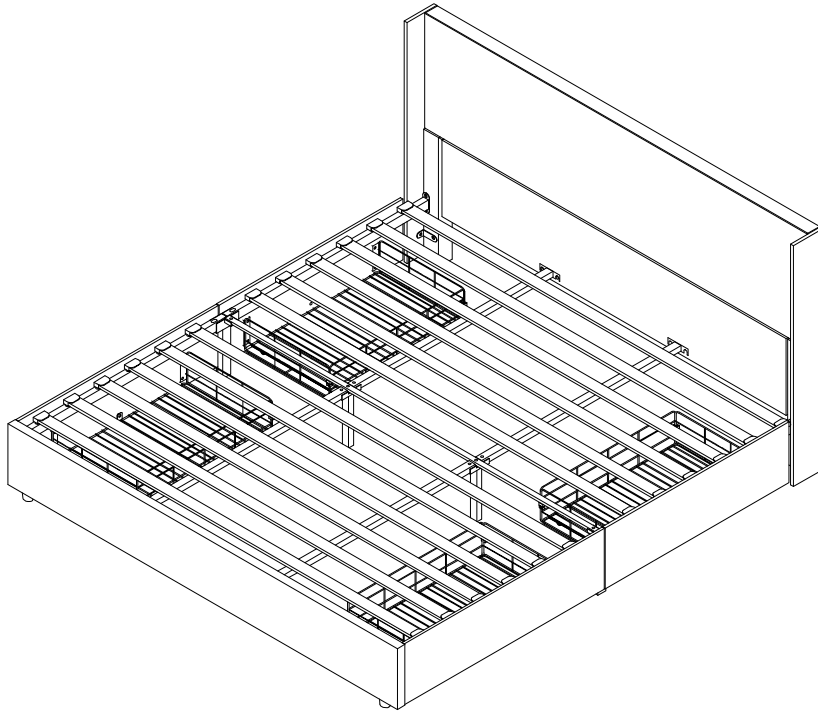

Trouble shooting:

Missing/Wrong/Broken parts and installation issues



Send email with your question,pic and order NO.to
support@garvee.com



Respond within 24 hours



Issue resolved

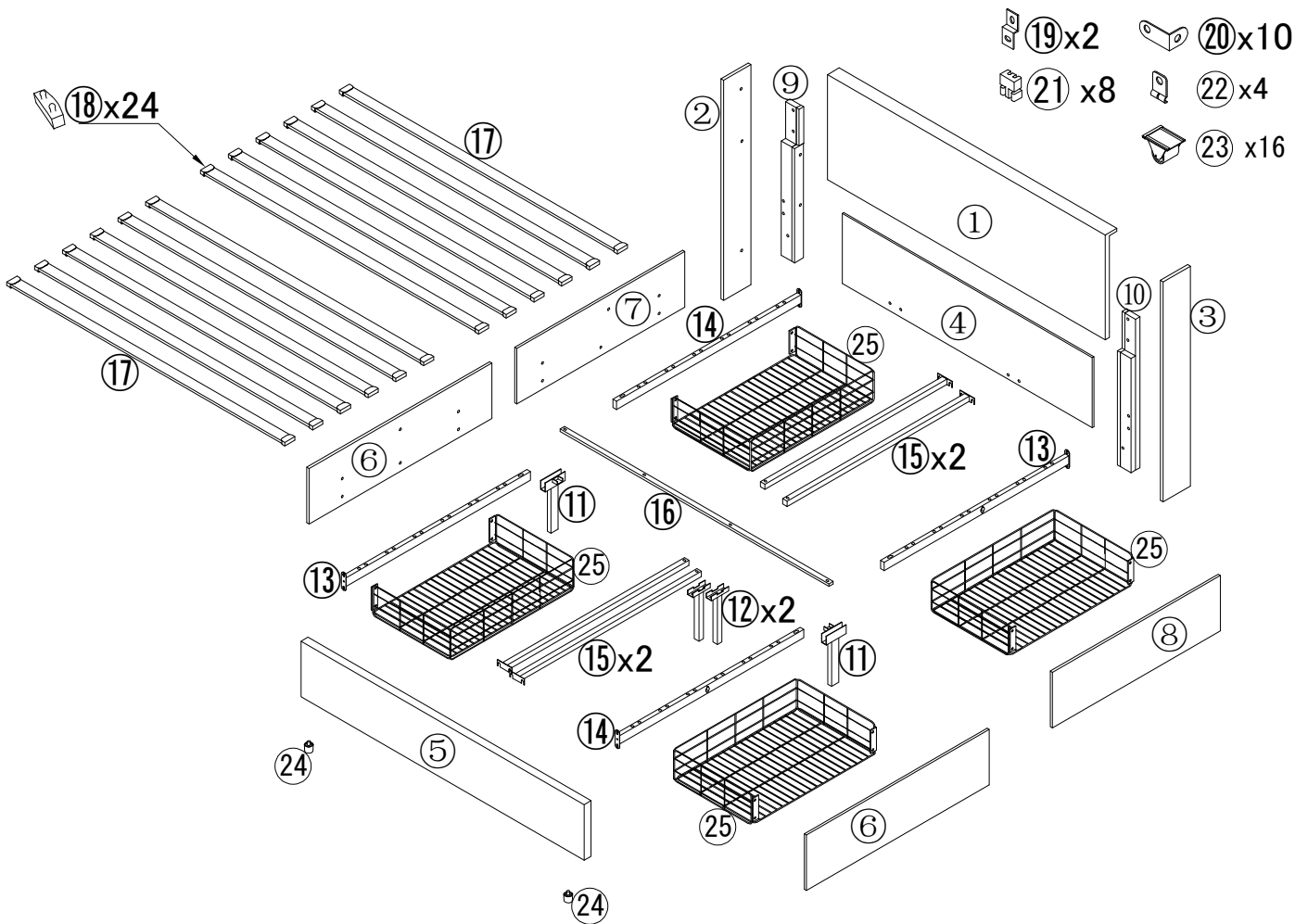

Note: Don't tighten all screws during installation.

Screws & Tools ▼

A		M6x12	X24
B		M8x10	X10
C		M8x15	X12
D		M8x18	X20
E		M8x35	X4
F		M8x45	X10
G		D5mm	X1
H		D4mm	X1

Please check all components & screws before assembly.

If parts are missing, do not install, Contact us for the missing parts.

Send email with your question to support@garvee.com
We will reply you within 24 hours.

Components ▼

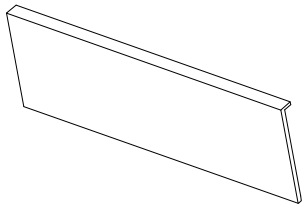

1 x1



2 x1



3 x1

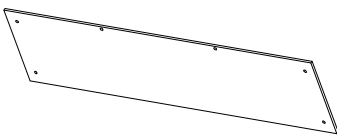

4 x1

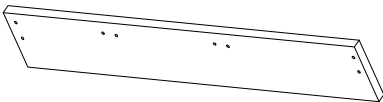

5 x1

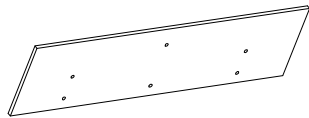

6 x2

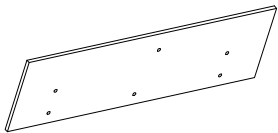

7 x1

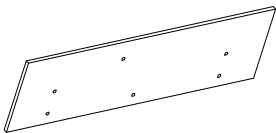

8 x1

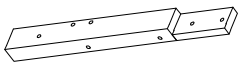

9 x1

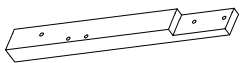

10 x1

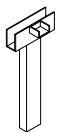

11 x2

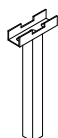

12 x2

Components ▼



13 x2



14 x2



15 x4



16 x1



17 x12



18 x24



19 x2



20 x10



21 x8



22 x4



23 x16





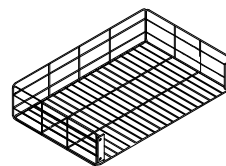

24 x2





25 x4

Step 1

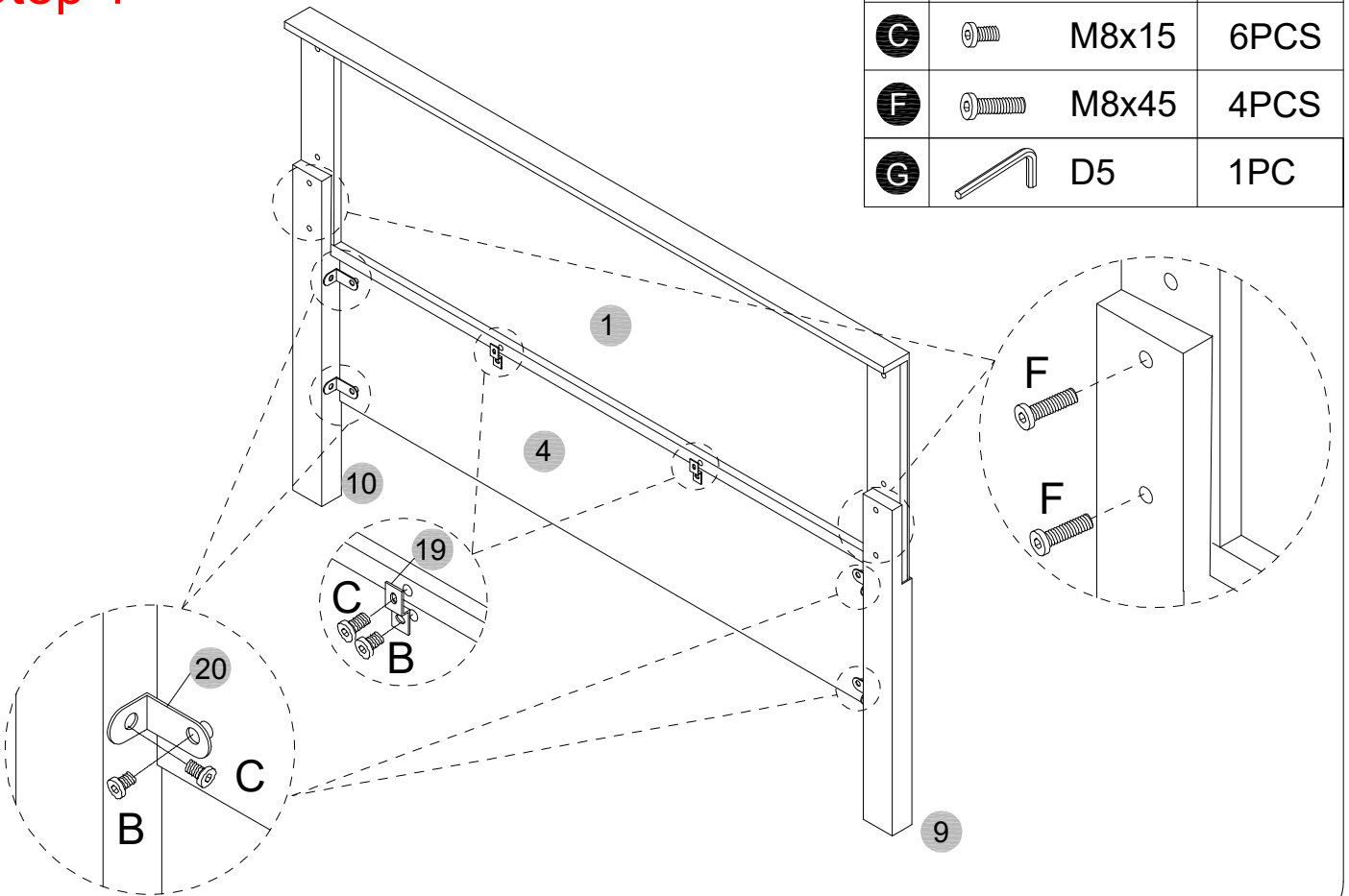
B		M8x10	6PCS
C		M8x15	6PCS
F		M8x45	4PCS
G		D5	1PC



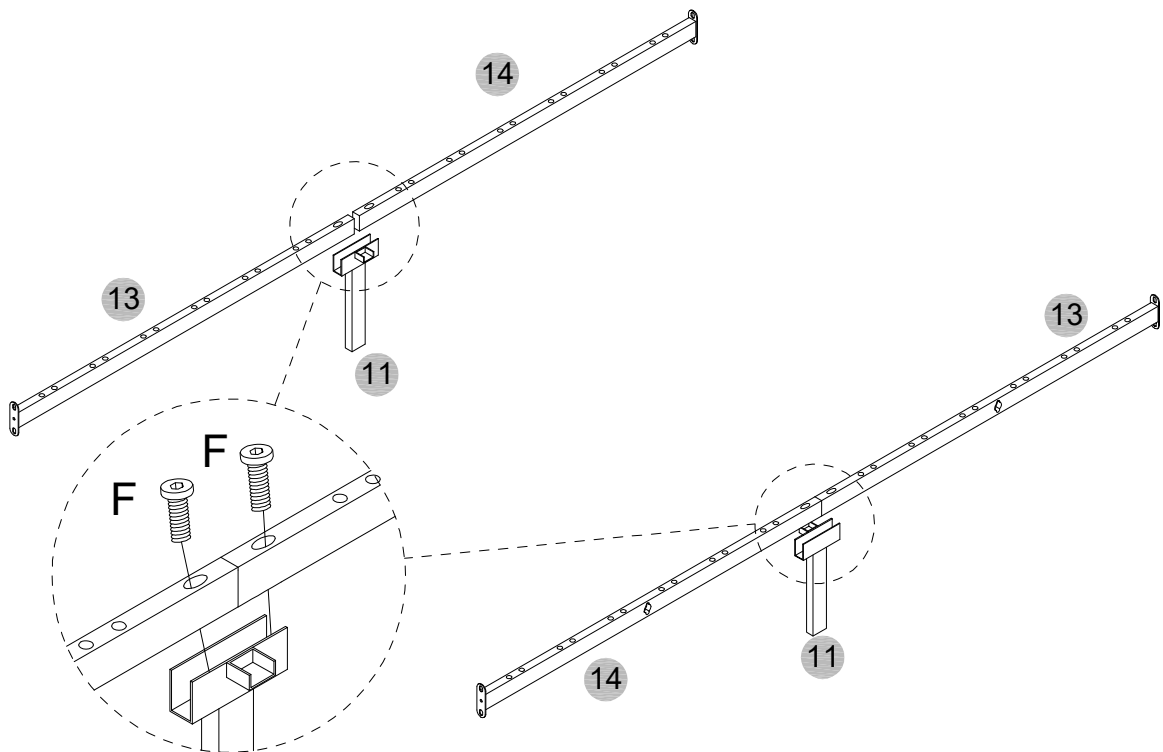

Step 2

F		M8x45	4PCS
G		D5	1PC





Step 3

Please pre-install the screws to 50% first.

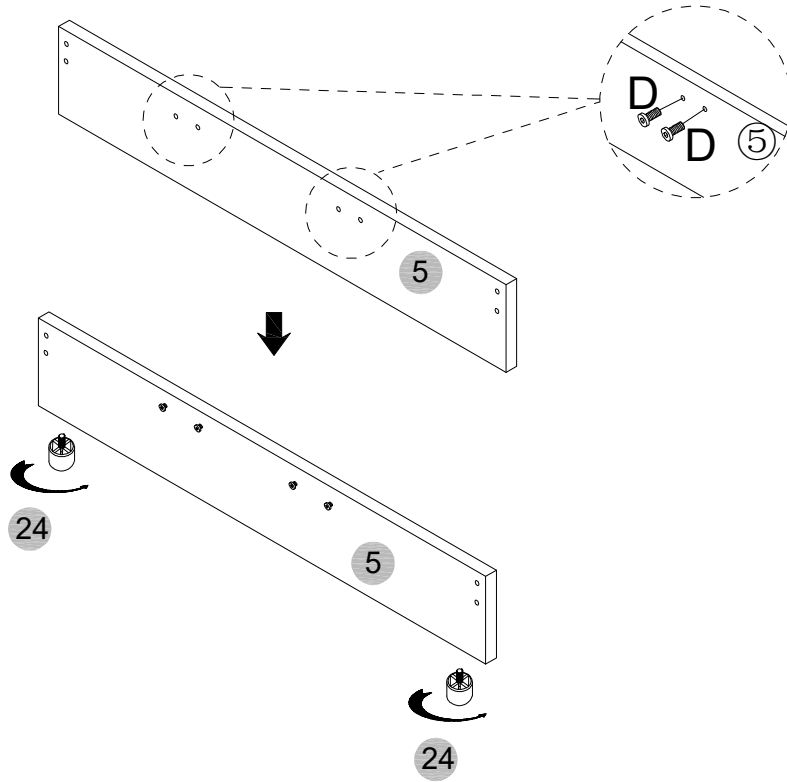
D		M8x18	4PCS
G		D5	1PC





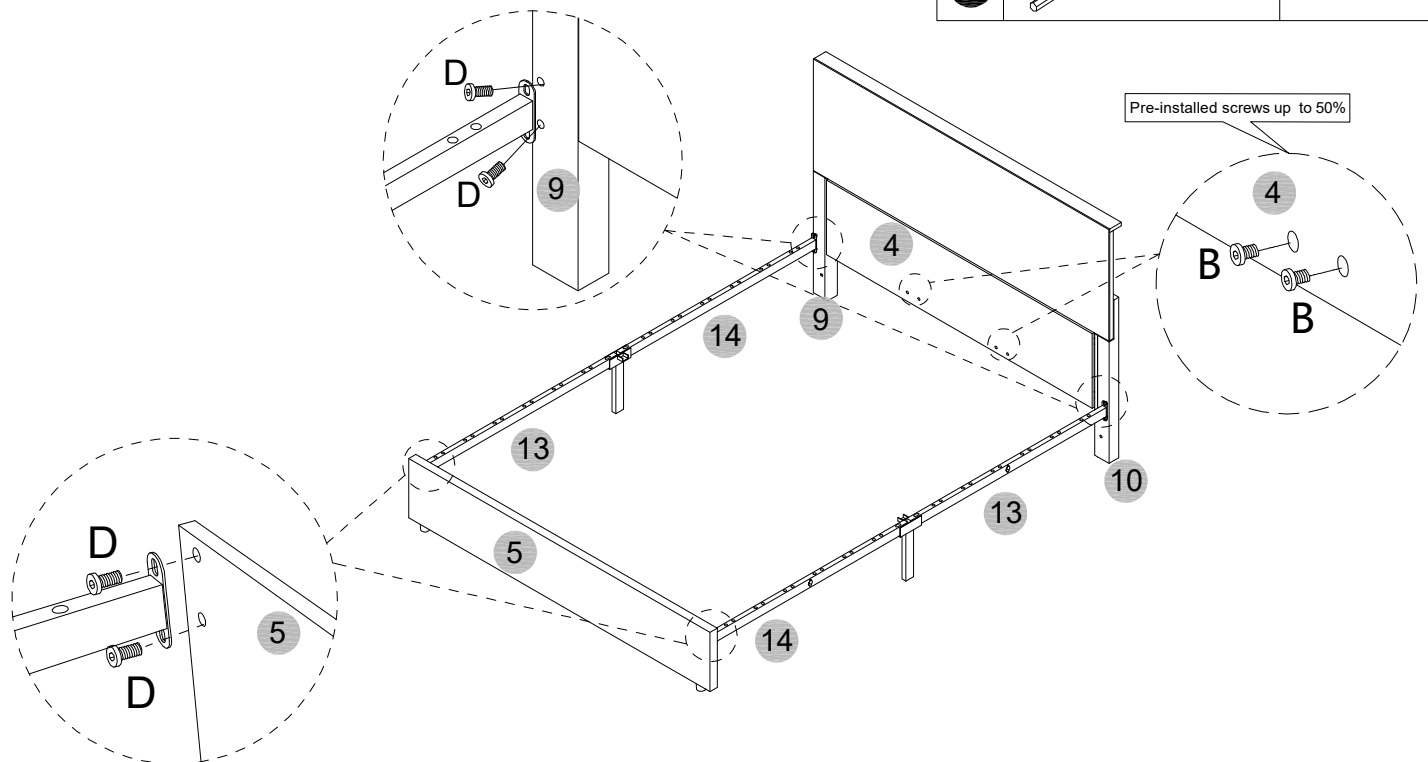

Step 4

B		M8x10	4PCS
D		M8x18	8PCS
G		D5	1PC



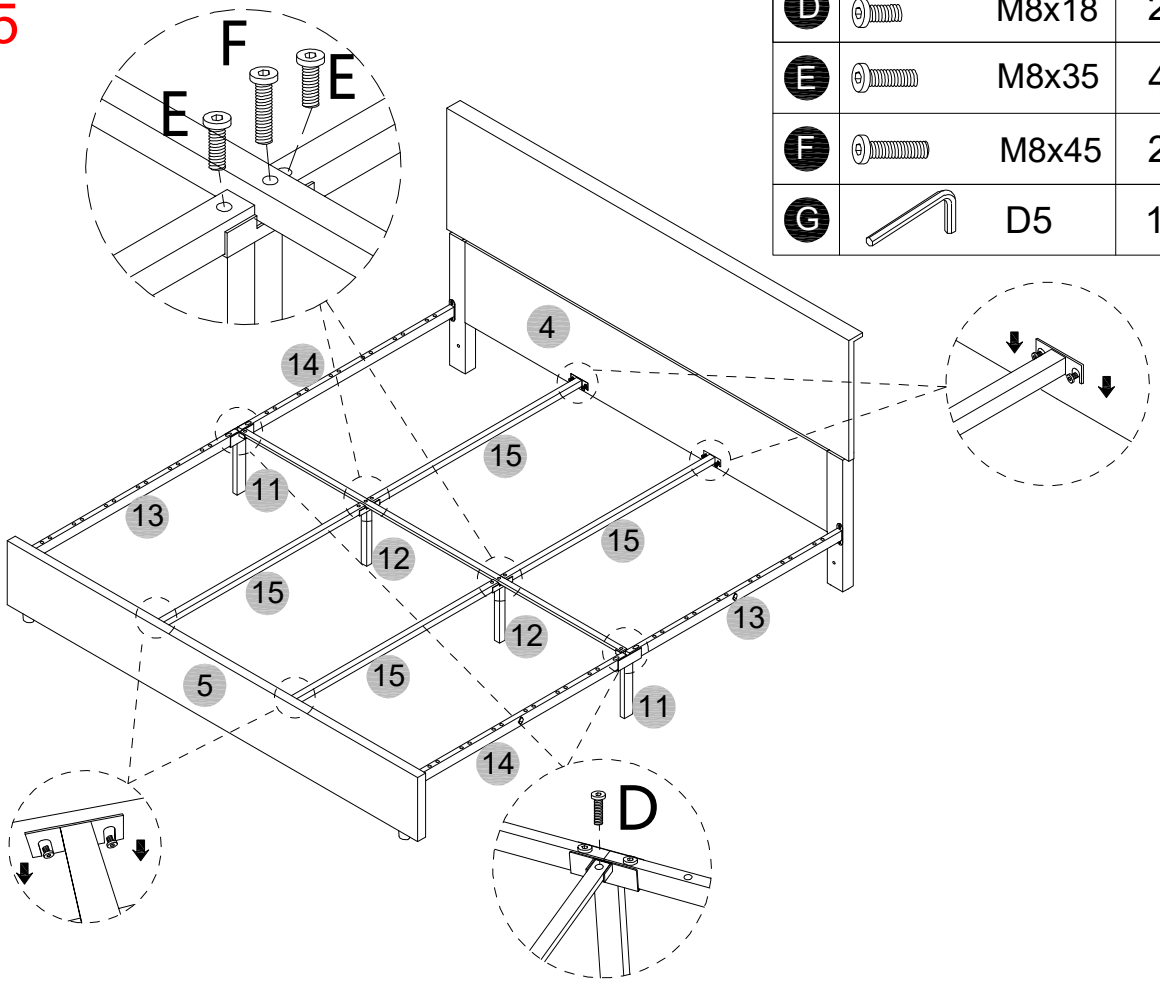

Step 5

D		M8x18	2PCS
E		M8x35	4PCS
F		M8x45	2PCS
G		D5	1PC



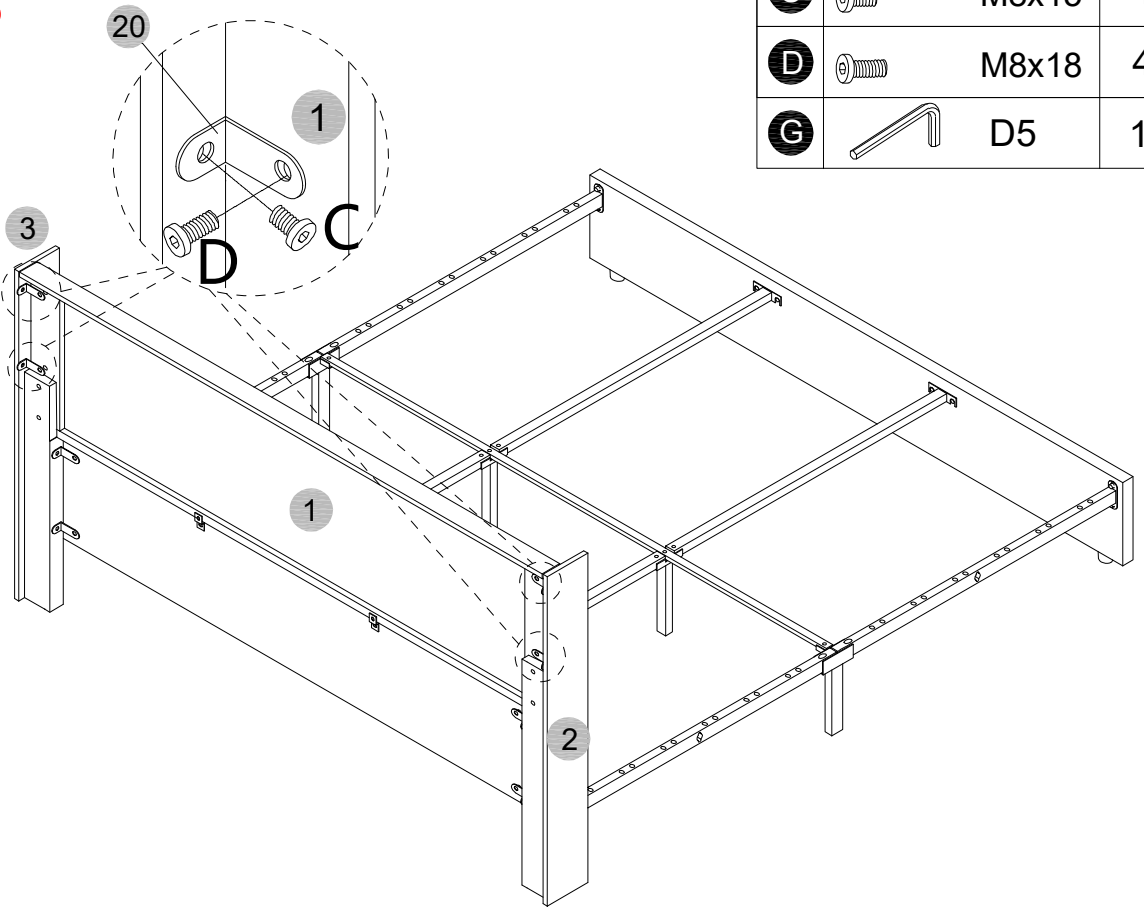

Step 6

C		M8x15	4PCS
D		M8x18	4PCS
G		D5	1PC



Step 7

C		M8x15	2PCS
D		M8x18	2PCS
G		D5	1PC

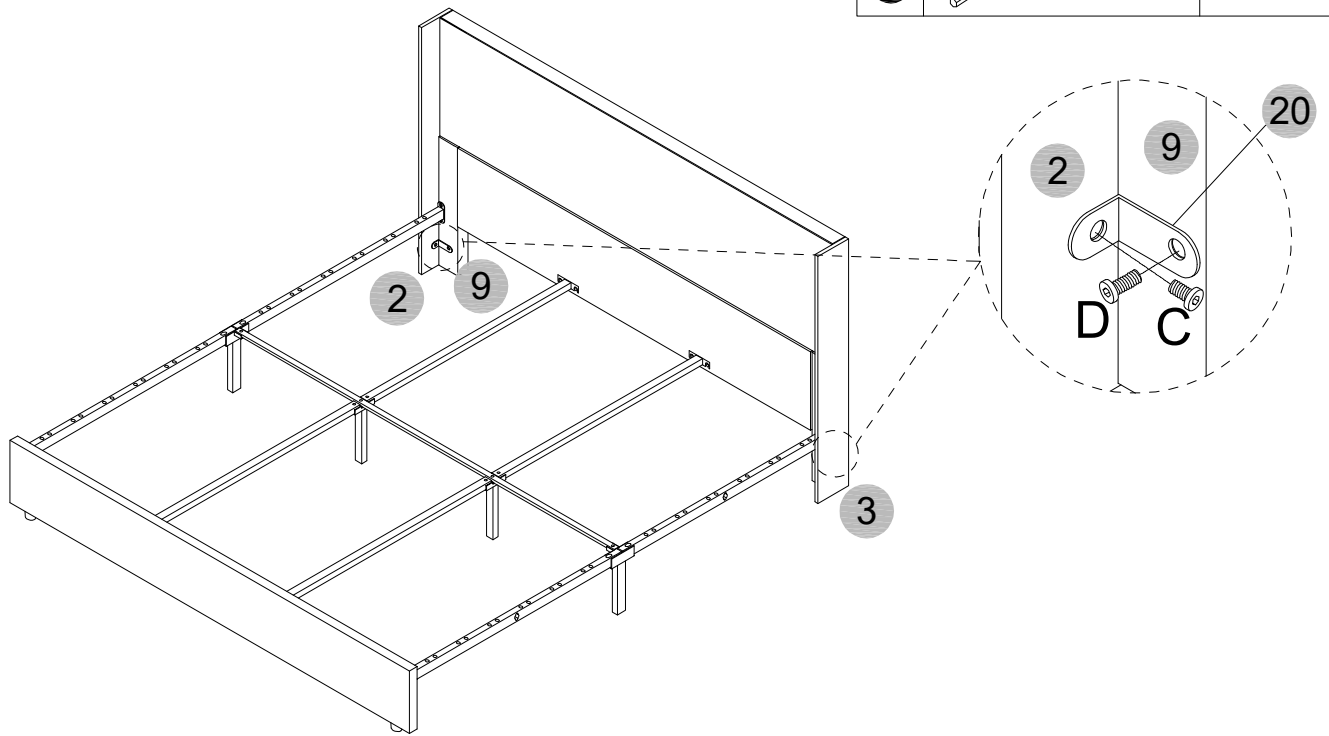

Step 8

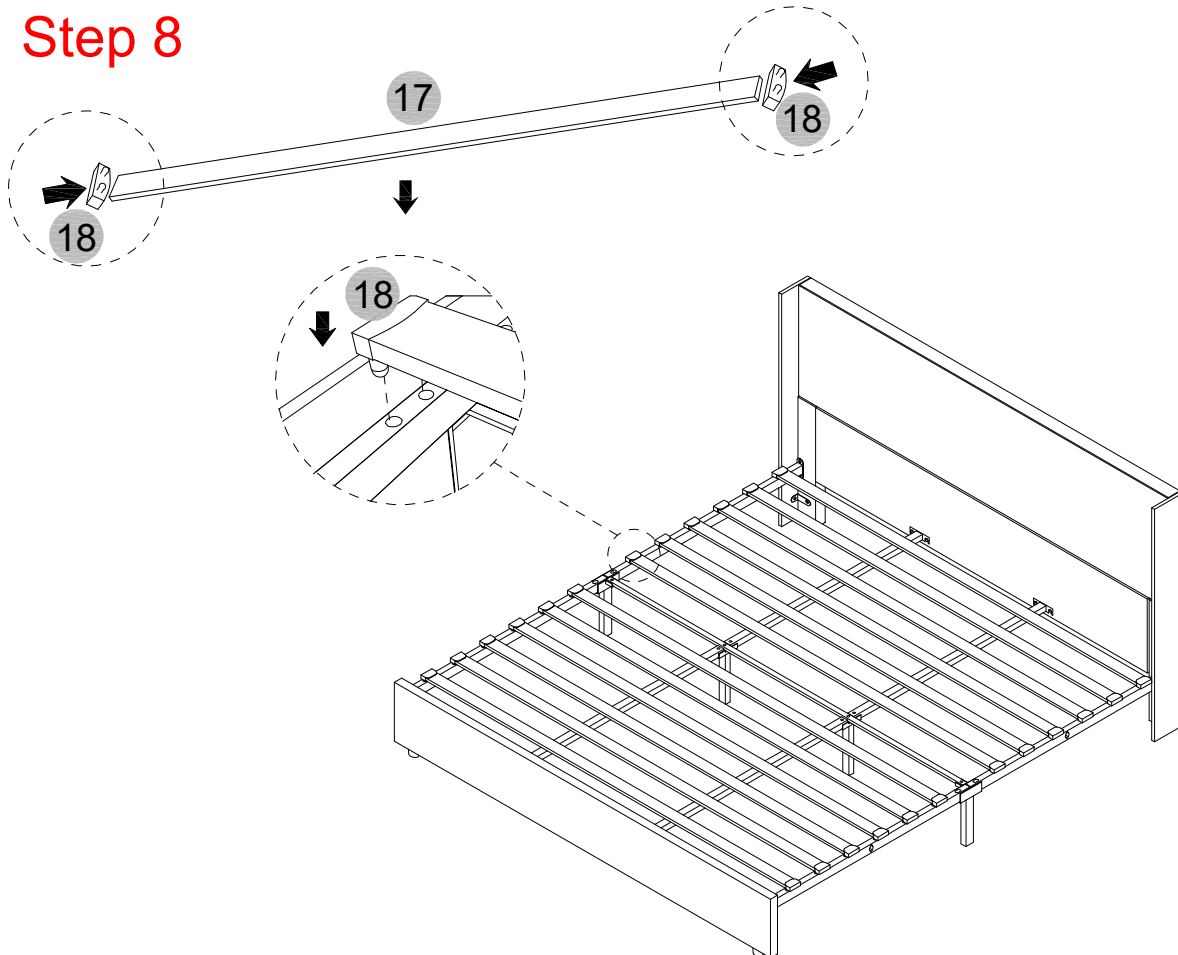

Step 9

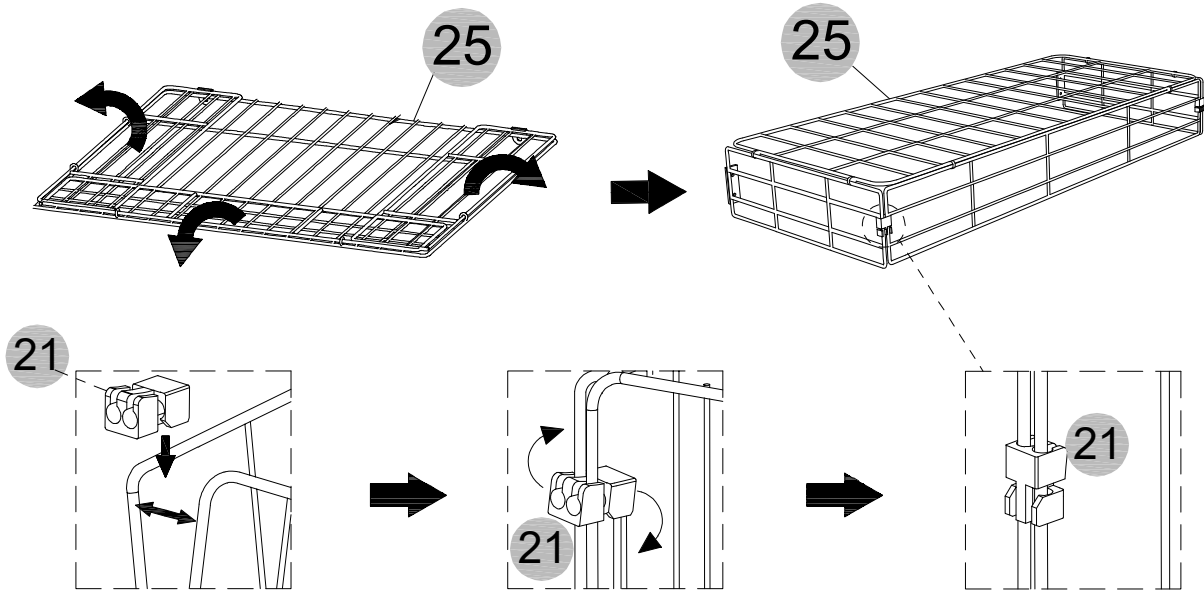

1, Take part 21 and insert it between the left and right steel bars, ensuring a tight fit.

2, Then, rotate part 21 to secure the steel bars in the inner and outer slots, ensuring a tight fit.

3, Finally, adjust the position so that the steel bar and the slot of part 21 fit perfectly.

x4

Step 10

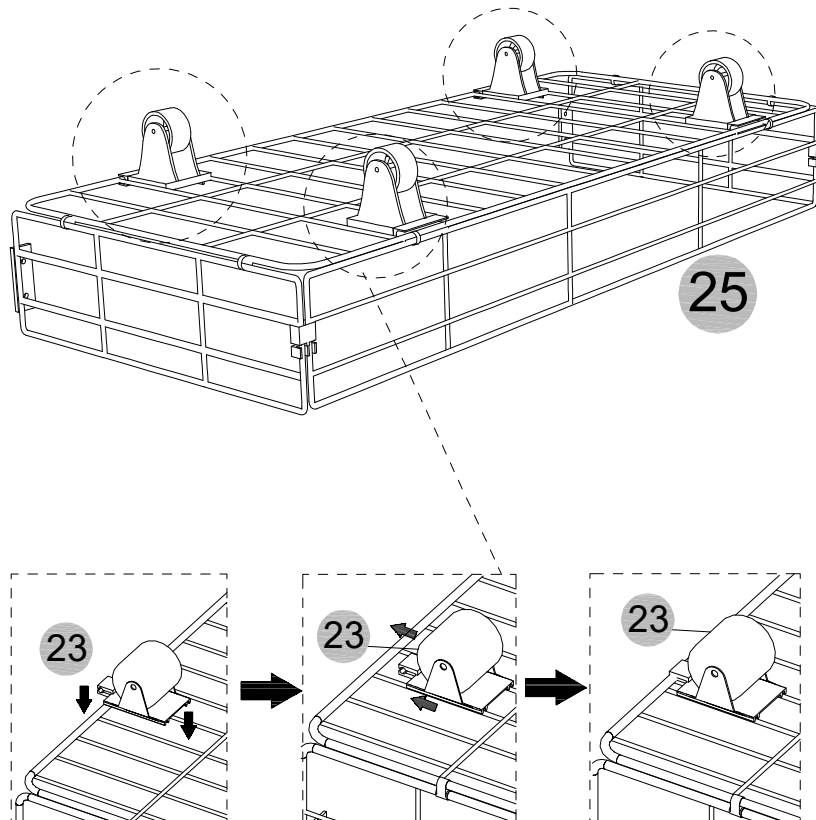

x4

x4

Step 11

A		M6x12	12PCS
H		D4	1PC

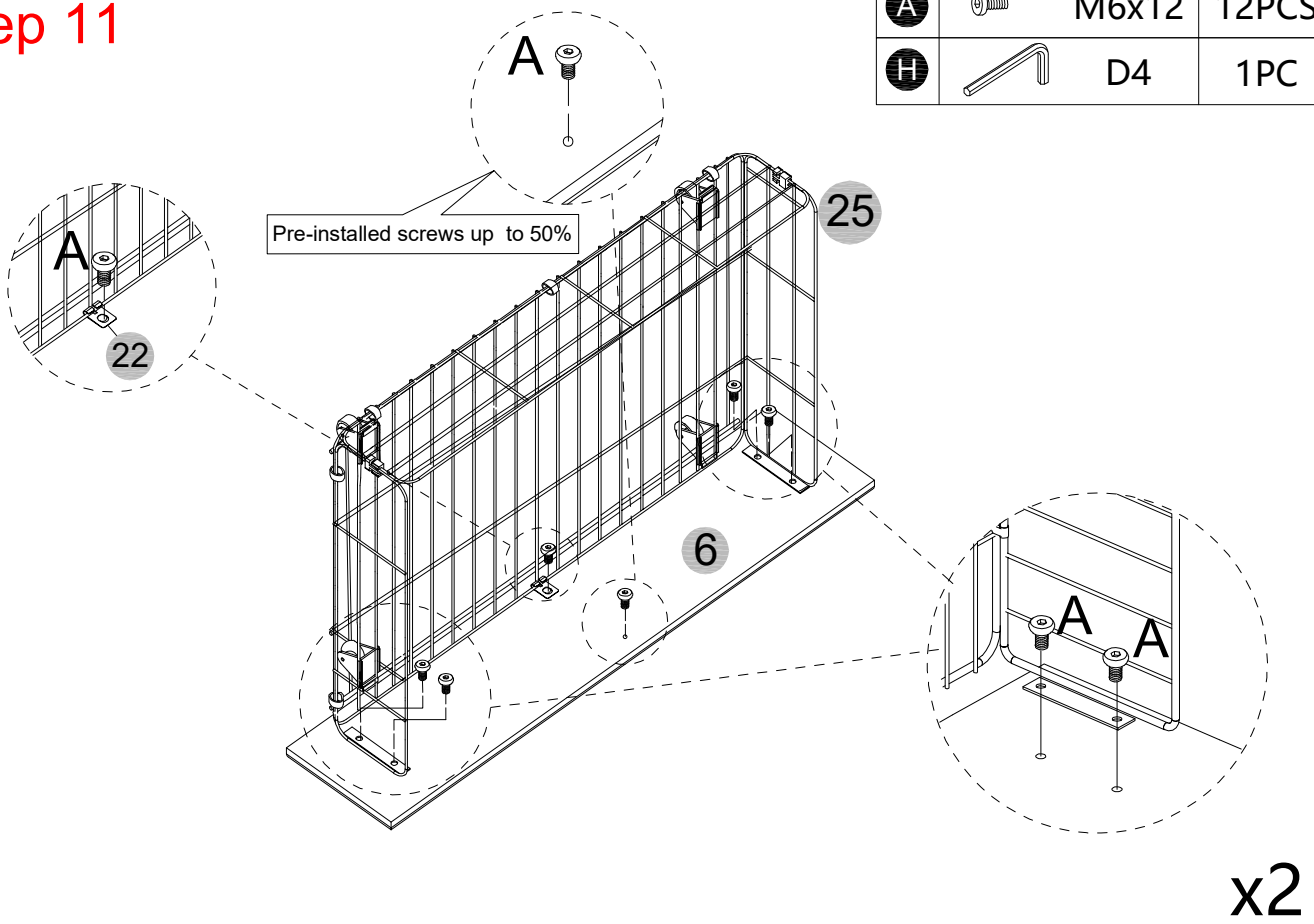

Step 12

A		M6x12	12PCS
H		D4	1PC

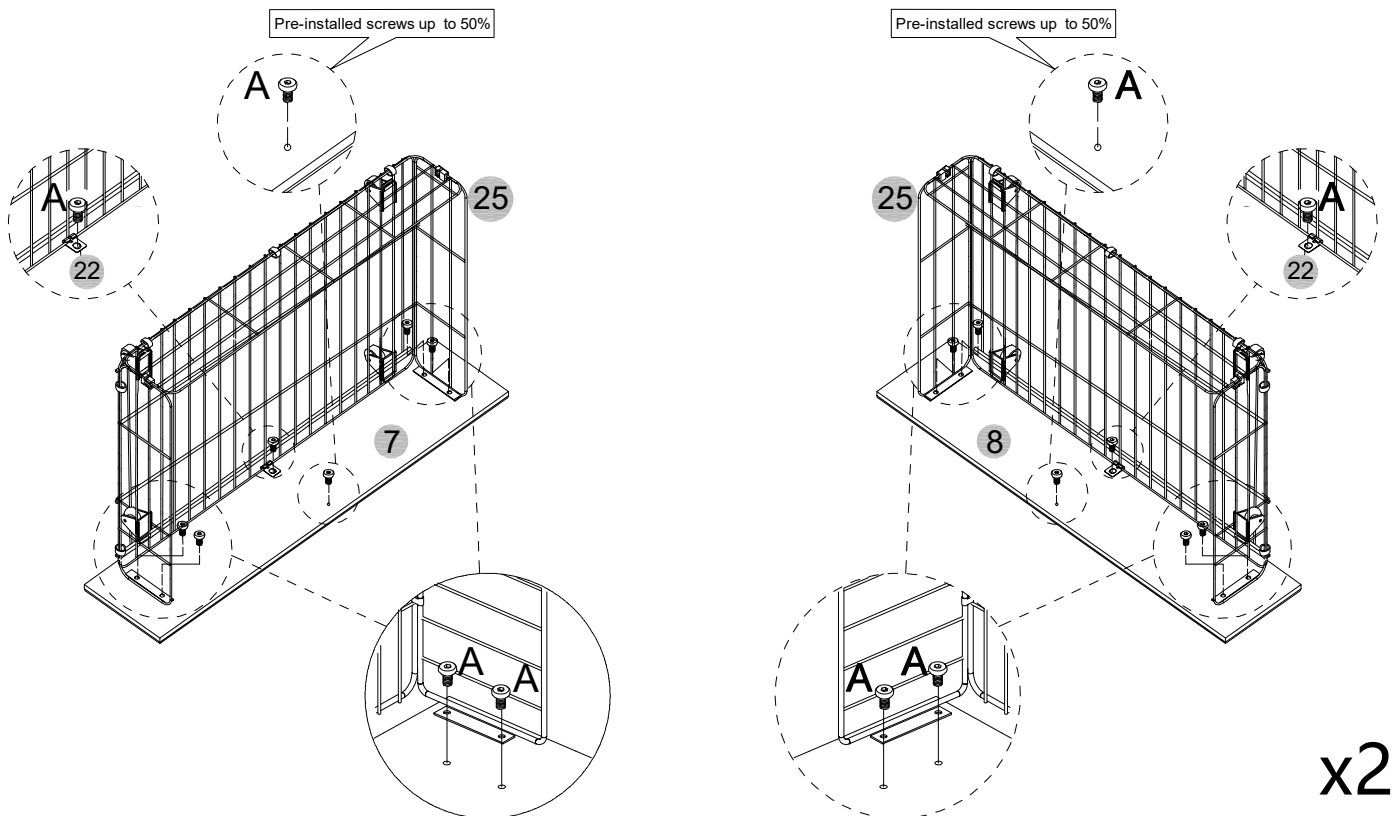

Step 13

When pushing into the drawer, gently lift the drawer, align the screws with the gourd holes and push in. When pulling out the drawer, gently lift the drawer, align the screws with the gourd holes, and pull it out.

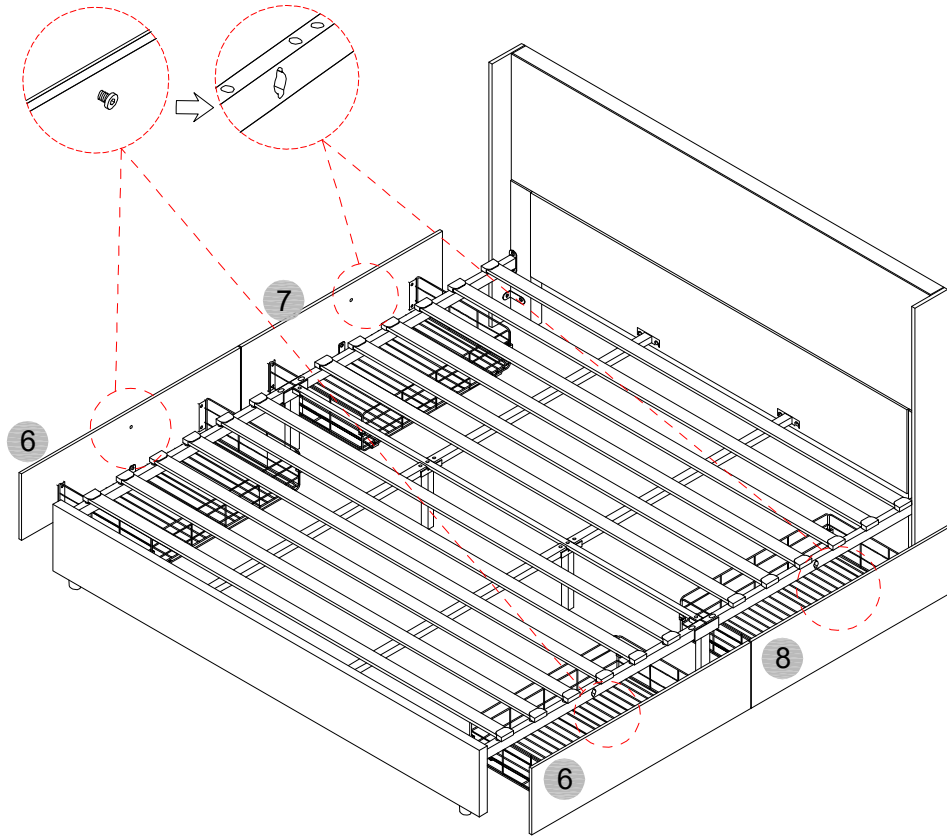

Step 14

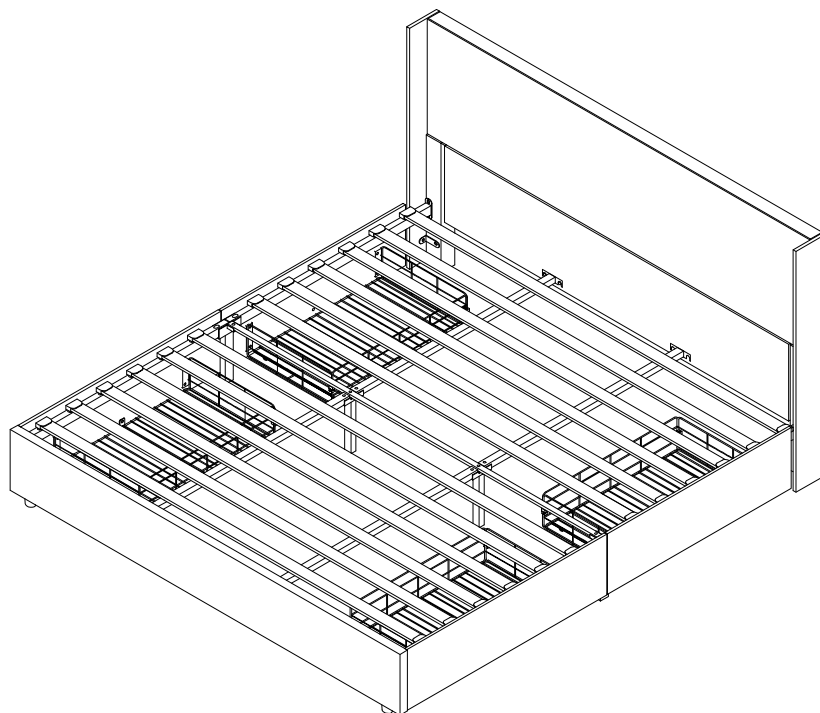

IMPORTANT SAFETY INFORMATION

Please carefully read the instructions and caution warnings below before assembling the product. Following this guide will ensure that you install, use and maintain the product properly.

- Please keep this installation and user manual/instructions for future reference in case you need to assemble the product.
- Do not assemble if you notice serious damage such as cracks or bends.
- During installation, please use work gloves for hand safety.
- Please assemble the unit on carpeted floor or the flat cardboard box to avoid scratching the surface or your floor while assembling on the floor.
- To assemble, please use the complimentary installation tools (Allen Wrench). Pay more attention to the direction of components at each steps.
- It is recommended that two people work together to assemble the product.
- Please do not tighten the screws up too much, just to 80% before you finish to make the installation go on successfully.

RETURN POLICY

We believe you will absolutely love your new product. But for some reason you want to return your item, please contact us within 30 days after receiving and ensure that the product which you want to return is in a good condition in the original box with all original certificates of purchase, manuals and accessories attached.

HOW TO MAINTAIN YOUR PRODUCT:

- Check the screws of the product are not loose from regular use.
- Do not use sharp instruments, rubbing alcohol, corrosive chemicals, or abrasive cleaners to clean the product.
- Do not keep the product in a damp environment for a long period of time. The damp environment may cause the iron components to rust and the plates to bulge and crack.

CAUTIONS!

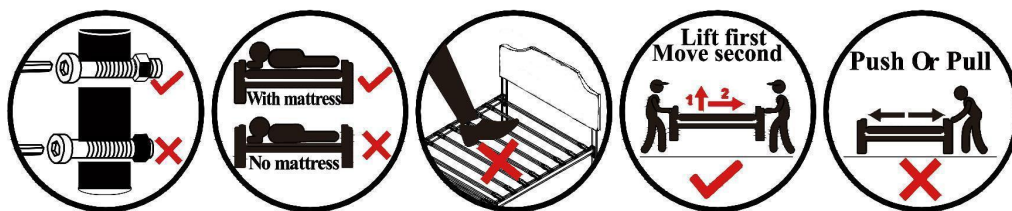

How to find us?

Customer Service

Email: support@garvee.com

Limited Liability & Warning

No Unauthorized Modifications/Repairs: Do not modify or attempt to repair this product unless you are an authorized technician. Unauthorized actions may create hazards and void all warranties

Misuse & Non-Compliance: We are not liable for any injury, damage, or loss resulting from:

- (a) misuse, abuse, neglect, or improper installation;
- (b) failure to follow instructions or safety precautions;
- (c) use of unauthorized parts/accessories;
- (d) unauthorized modifications/repairs;
- (e) accidents, natural disasters, or external causes.

If you doubt any step of installation or operation, stop using the product and contact authorized service or the customer support.

LIMITACIÓN DE RESPONSABILIDAD Y ADVERTENCIA

Modificaciones o Reparaciones No Autorizadas: NO modifique ni intente reparar este producto a menos que sea un técnico autorizado. Las acciones no autorizadas pueden generar riesgos y anularán todas las garantías.

Uso Indevido e Incumplimiento: No asumimos responsabilidad alguna por lesiones, daños o pérdidas que resulten de:

- (a) uso indebido, abuso, negligencia o instalación incorrecta;
- (b) incumplimiento de las instrucciones o precauciones de seguridad;
- (c) uso de piezas o accesorios no autorizados;
- (d) modificaciones o reparaciones no autorizadas;
- (e) accidentes, desastres naturales o causas externas.

Si tiene dudas sobre algún paso de la instalación o el funcionamiento, deje de usar el producto y póngase en contacto con el servicio técnico autorizado o con atención al cliente.

GARVEE
support@garvee.com