





CARE AND MAINTENANCE

Wipe clean with a soft, dry cloth. The seat board can be cleaned with a mild cleaner. Test the cleaning method on a hidden area before using them over the entire area.

NOTICE

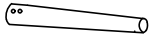
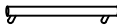
- * Please make sure that you have all parts indicated before you begin assembly of this item.
- * This item should be assembled on a soft surface to prevent scratching the finished product during assembly.
- * This item may require periodic tightening.
- * Do not tighten bolts until completely assembled.

Part List and Hardware List

PIECE	DESCRIPTION	PICTURE	QUANTITY
A	DRAWER		1 X
B	LEG		4 X
HW1	Handle	 160mm	1 X
HW2	Hex Socket Bolt	 5/16"-18 x 2-1/4"	8 X
HW3	Phillips Bolt	 5/32"*20mm	2 X
HW4	Allen Key	 M4	1 X
HW5	Anti-Tip Hardware		2 X

SAFAVIEH

C O U T U R E

Model# SFV2116

Product Dimensions:39"W*18"D*27"H

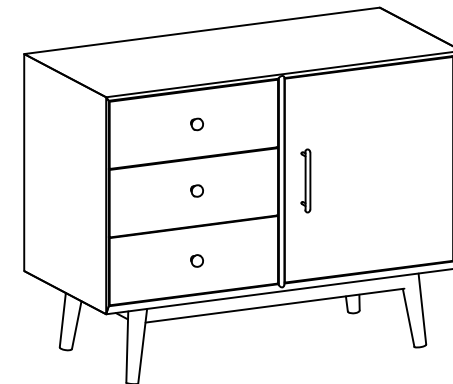

Weight Capacity : 40 lbs on top of the product
25 lbs on shelf

Warning : Do not stand on the product

Warning : Do not over torque bolts.

PREPARATION

Before beginning assembly of product, make sure all parts are present. Compare parts with package contents list and hardware contents list. If any part is missing or damaged, do not attempt to assemble the product.

Estimated Assembly Time:20 minutes.

Tools Required for Assembly : Allen key (included) & Phillips head screwdriver (not included)

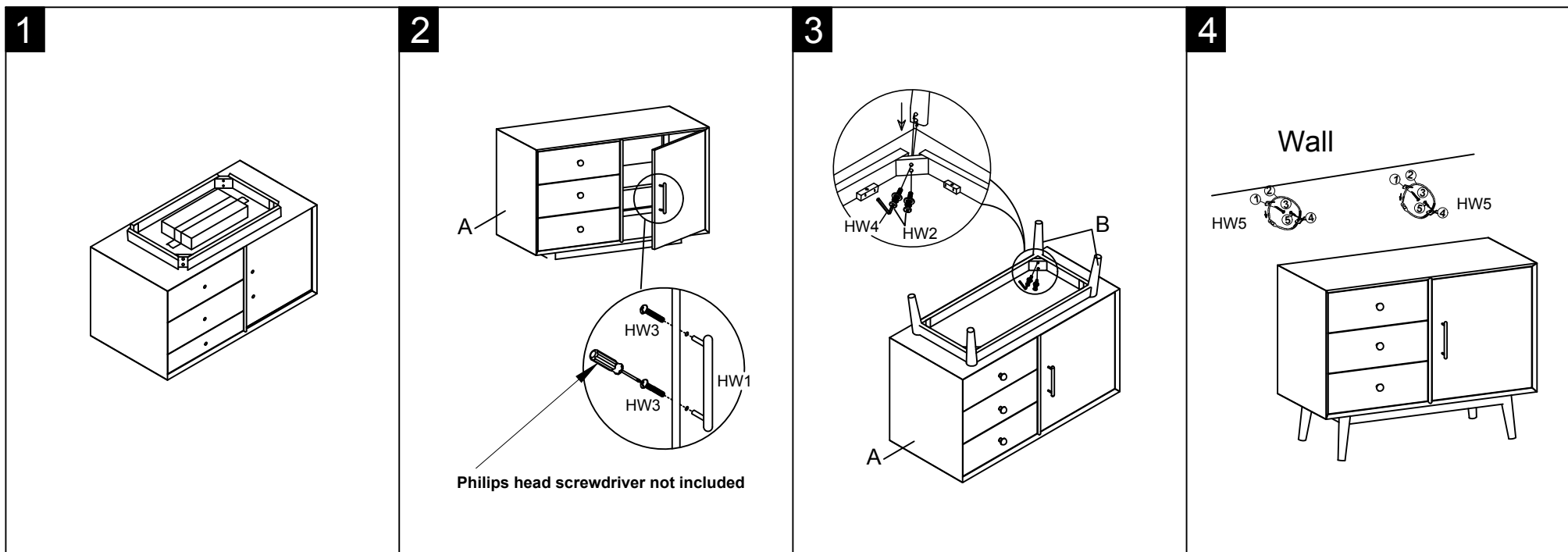

Notice :

HANDLE, 4*LEGS and
HARDWARE BAG AT THE
BOTTOM OF THIS PRODUCT.

Step 1

Open the door then installed the Handle (HW1) on the inside of Door by using a Phillips head screwdriver (not included) to lock with 2*Phillips Bolt (HW3).
P.S. How to remove and install the drawer knob, please see another assembly instruction.

Step 2

Attach 4*Legs (B) in the corresponding position on the underneath of Drawer (A) by using Allen key (HW4) to lock with 8*Hex Socket Bolt (HW2), As picture.

Step 3

Straighten up the assembled product. Following the installation instructions of anti-tipping (HW5) to fix the product in the wall by 2 straps. Assembly is completed.