

ASSEMBLY INSTRUCTION

Important note :

- Place all wooden part on a clean and smooth surface such as rug or carpet to avoid the part from being scratch.
- Please follow the assembly instruction step by step
- Do not tighten all screw until the table is fully set-up

PARTS LIST		
NO	DESCRIPTION	QTY
A	TABLE TOP	1
B	LONG APRON	2
C	SHORT APRON	2
D	TABLE LEG	4

HARDWARE LIST		
NO	DESCRIPTION	QTY
1	JCBC SCREW M6 x 35mm	16 PCS
2	SPRING WASHER	16 PCS
3	FLAT WASHER	16 PCS
4	CSK SCREW M4 x 32mm	8 PCS
5	ALLEN KEY	1 PC

STEP 1

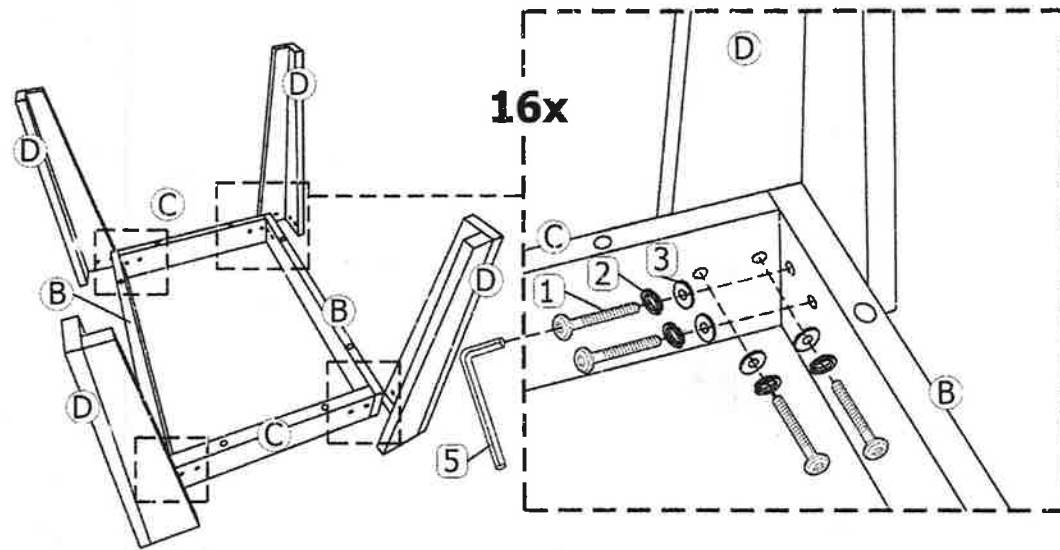

STEP 2

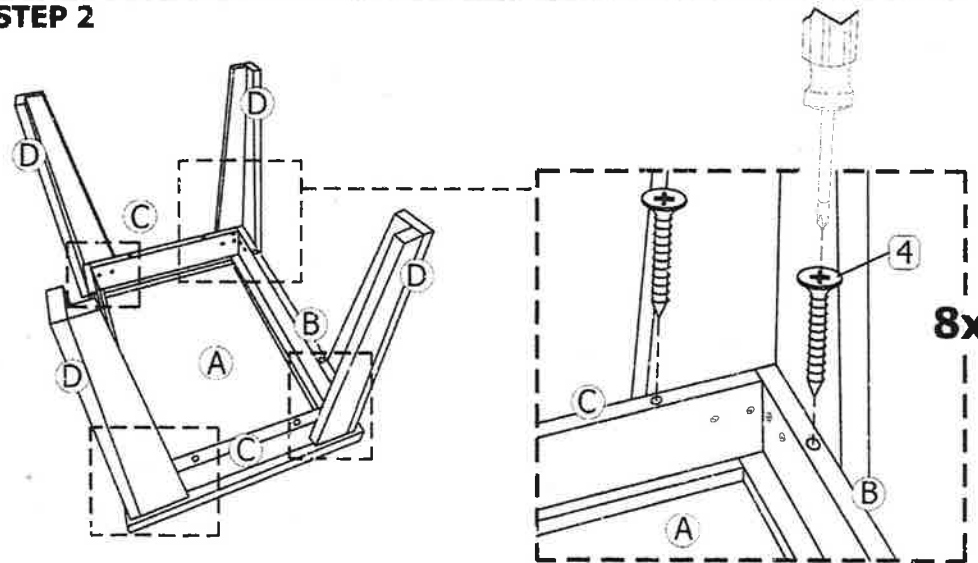





STEP 3



ASSEMBLY INSTRUCTION

Important note :

- Placez toutes les pieces en bois sure une surface propre et lisse, comme un tapis pour eviter les rayures
- Suivez les instructions d'assemblage etape par etape
- Ne pas serrer toutes les vis jusqu'a ce que la table est entierement mis en place

PARTS LIST		
NO	DESCRIPTION	QTY
A	Dessus de la table 	1
B	Longue bordure 	2
C	Court bordure 	2
D	Pied de table 	4

HARDWARE LIST		
NO	DESCRIPTION	QTY
1	JCBC SCREW M6 x 35mm 	16 PCS
2	Rondelle élastique 	16 PCS
3	Rondelle plate 	16 PCS
4	CSK SCREW M4 x 32mm 	8 PCS
5	Cle Allen 	1 PC

STEP 1

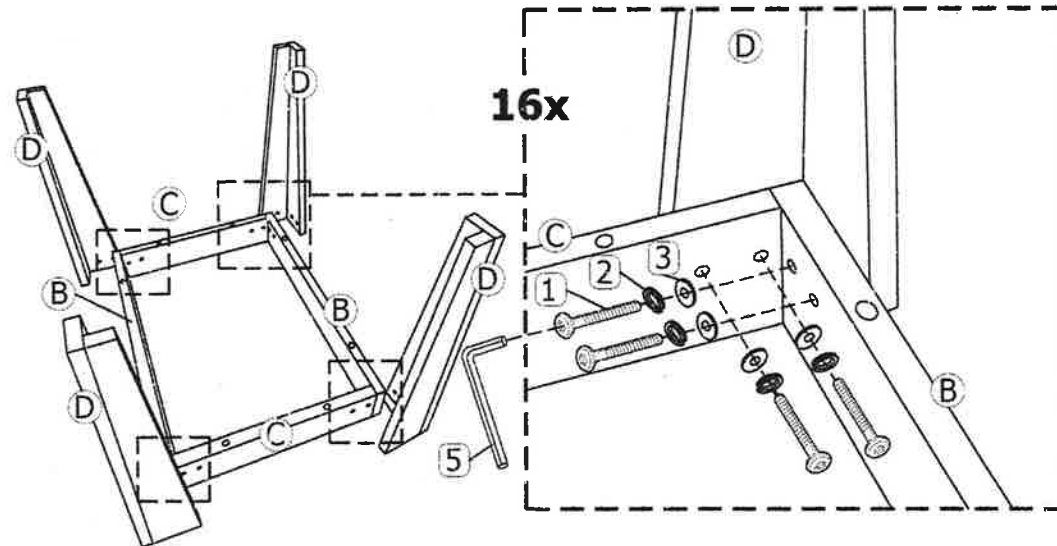

STEP 2

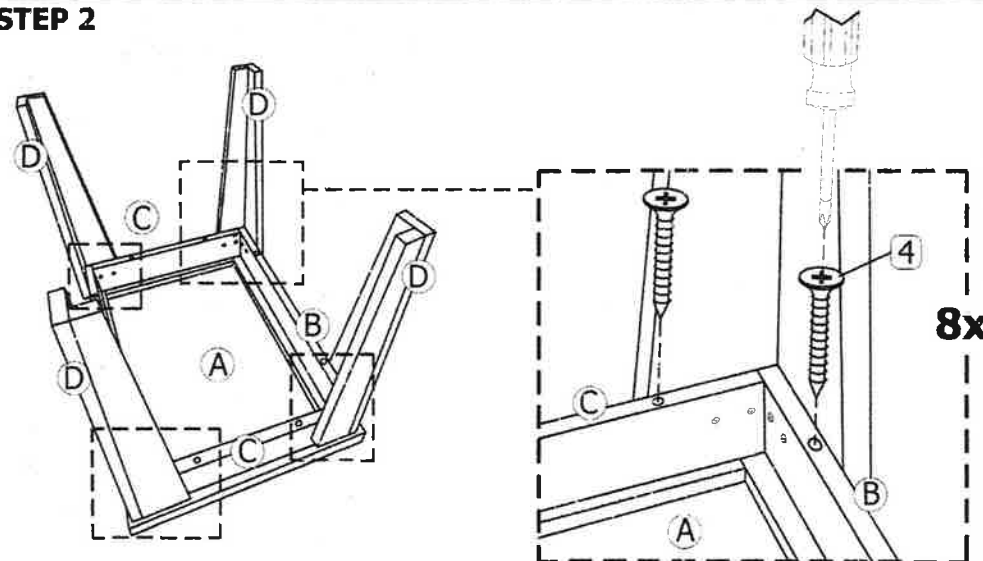

STEP 3

