

ASSEMBLY INSTRUCTIONS

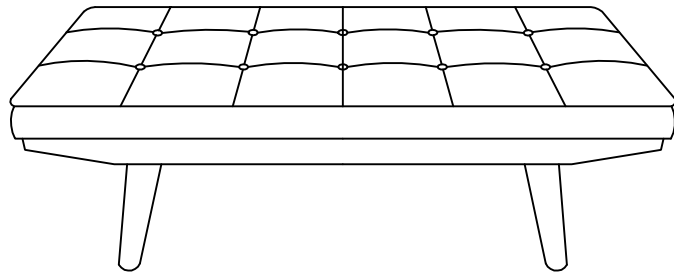

ASSEMBLY INSTRUCTIONS

ASSEMBLY TIPS:

1. Remove hardware from box and sort by size.
2. Please check to see that all hardware and parts are present prior start of assembly.
3. Please follow attached instructions in the same sequence as numbered to assure fast & easy assembly.



WARNING!

1. Don't attempt to repair or modify parts that are broken or defective .Please contact the store immediately.
2. This product is for home use only and not intended for commercial establishment.





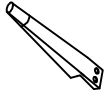
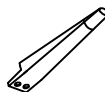

ASSEMBLY TIME

10 MINUTES

PARTS IDENTIFICATION

A	SEAT		1PC
B	LEG B		2PCS
C	LEG C		2PCS

Z HARDWARE IDENTIFICATION

1	ALLEN KEY (M5mm)		1PC
2	BOLT(Ø5/16"*1-1/2")		8PCS
3	SPRING WASHER-BIG (Ø5/16")		8PCS
4	FLAT WASHER-BIG (Ø5/16"*22mm)		8PCS

ASSEMBLY INSTRUCTIONS

STEP 1

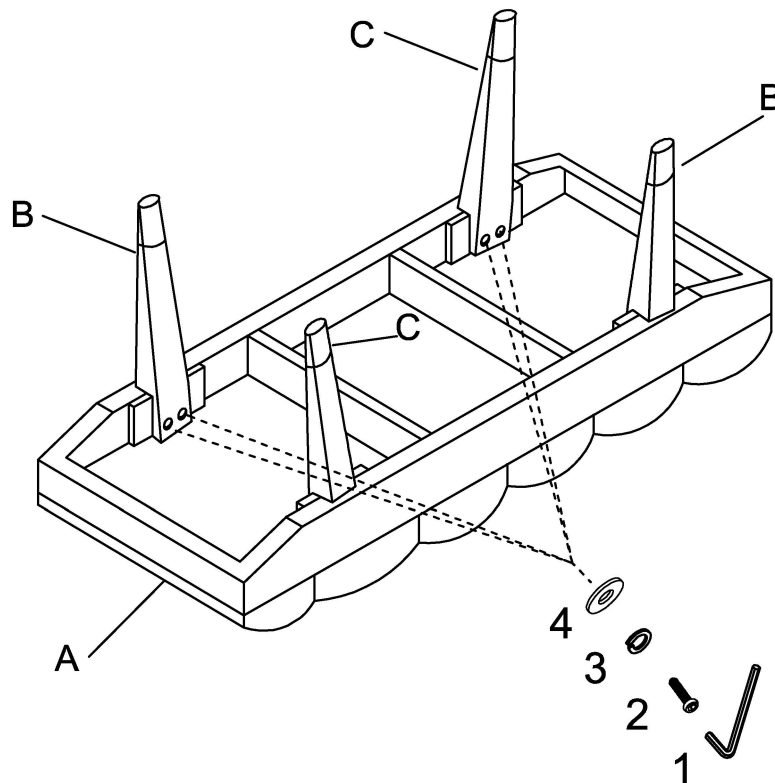

STEP 2

