

ASSEMBLY INSTRUCTIONS

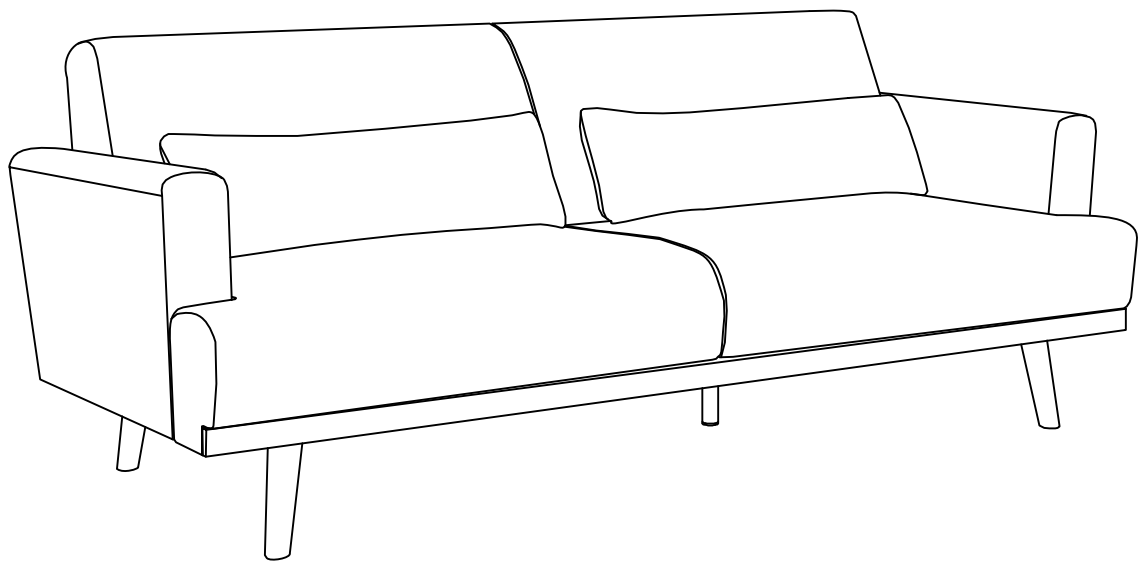

ASSEMBLY INSTRUCTION

ASSEMBLY TIPS:

1. Remove hardware from box and sort by size.
2. Please check to see that all hardware and parts are present prior to start of assembly.
3. Please follow attached instructions in the same sequence as numbered to assure fast & easy assembly.



WARNING!



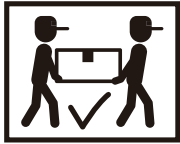

1. Don't attempt to repair or modify parts that are broken or defective. Please contact the store immediately.
2. This product is for home use only and not intended for commercial establishments.





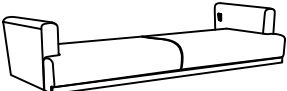

ASSEMBLY TIME

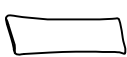
15 MINUTES

PARTS IDENTIFICATION

A	BODY		1 PC	B	BACK		1 PC
C	LEG		4 PCS	D	SUPPORT LEG		1 PC
E	PILLOW		2 PCS				

HARDWARE PACKAGE

1	BOLT		M8*65mm	4 PCS	2	WASHER		9*19mm	4 PCS
3	ALLEN WRENCH		M5	1 PC	4	PLASTIC WASHER			1 PC

ASSEMBLY INSTRUCTION

STEP1:

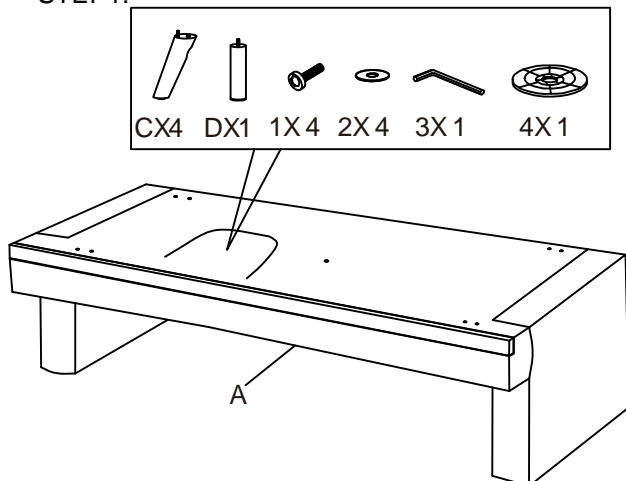

STEP2:

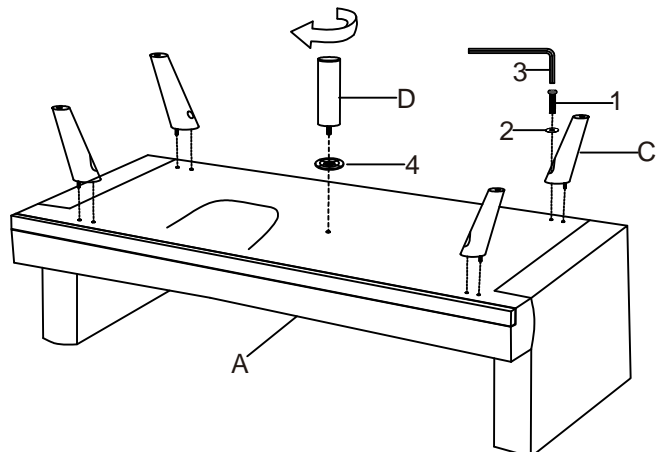

STEP3:

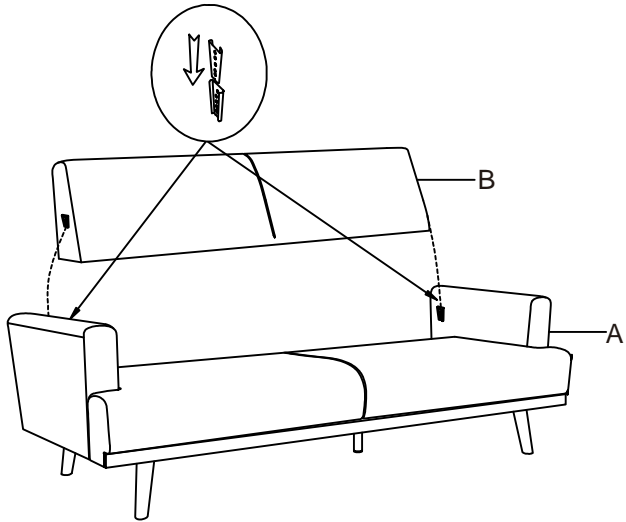

STEP4:

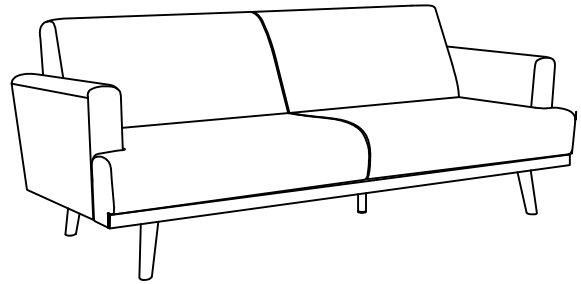

STEP5:

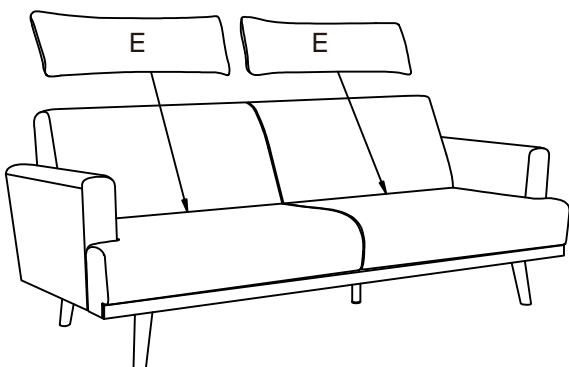

STEP6:

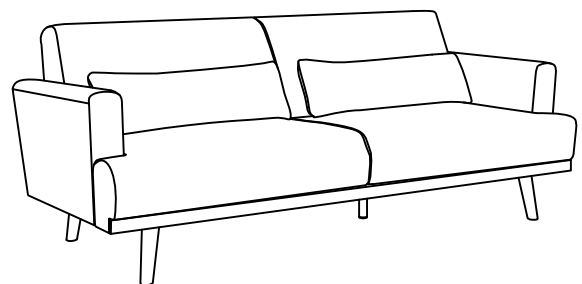

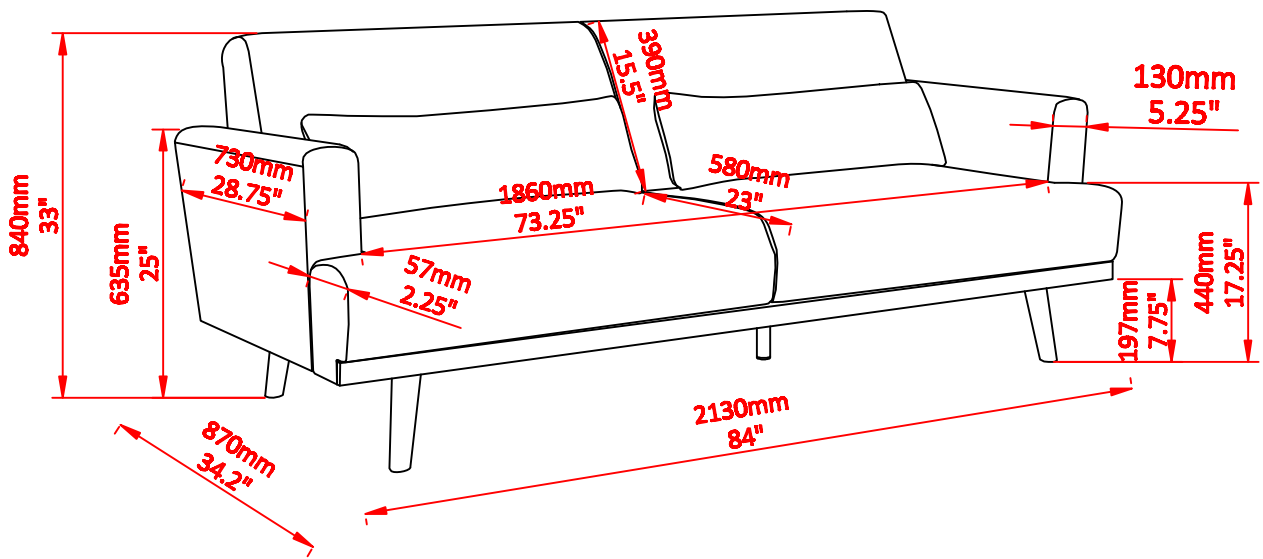

Note : Dimension tolerance $\pm 5\%$