

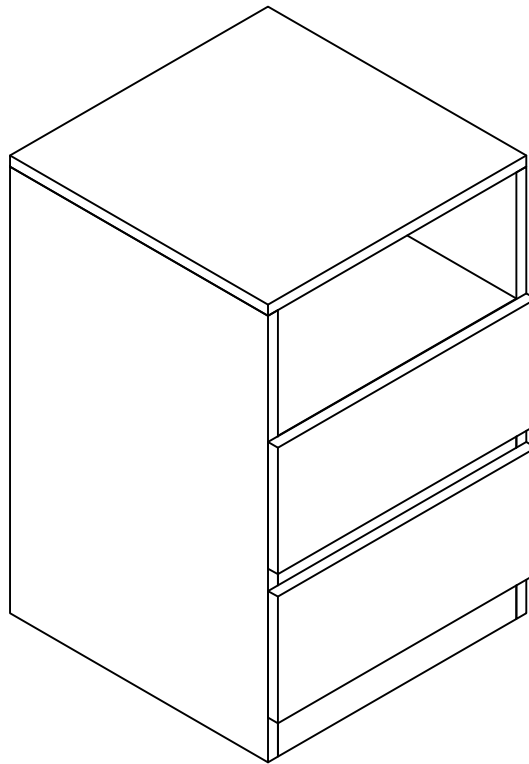









# Drawers Cabinet Installation Instructions



## Disassembly and installation of accessories

The letter in the top-left corner indicates the parts bag number, with the adjacent number showing the included quantity. Bottom text specifies product dimensions. Before installation, please verify all parts. For missing/damaged items, contact us - we'll promptly supply replacements.

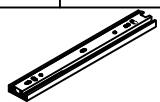

<p>1.</p> <p>This part cannot be separated, please install in strict accordance with the assembly requirements</p>	<p>2.</p>	<p>3.</p>	<p>4.</p>	<p>5.</p>
--	-----------	-----------	-----------	-----------

<p><b>A</b> 28PCS</p>  <p>Ø15*10mm</p>	<p><b>B</b> 28PCS</p>  <p>Ø6*35mm</p>	<p><b>C</b> 4PCS</p>  <p>Ø8*30mm</p>	<p><b>D</b> 4PCS</p>  <p>decorative stickers</p>	<p><b>E</b> 8PCS</p>  <p>Ø3.5*35mm</p>	<p><b>F</b> 26PCS</p>  <p>Ø3.5*14mm</p>	<p><b>H</b> 4PCS</p> 
<p><b>K</b> 4PCS</p>  <p>10"</p>	<p><b>L</b> 1PC</p> 					

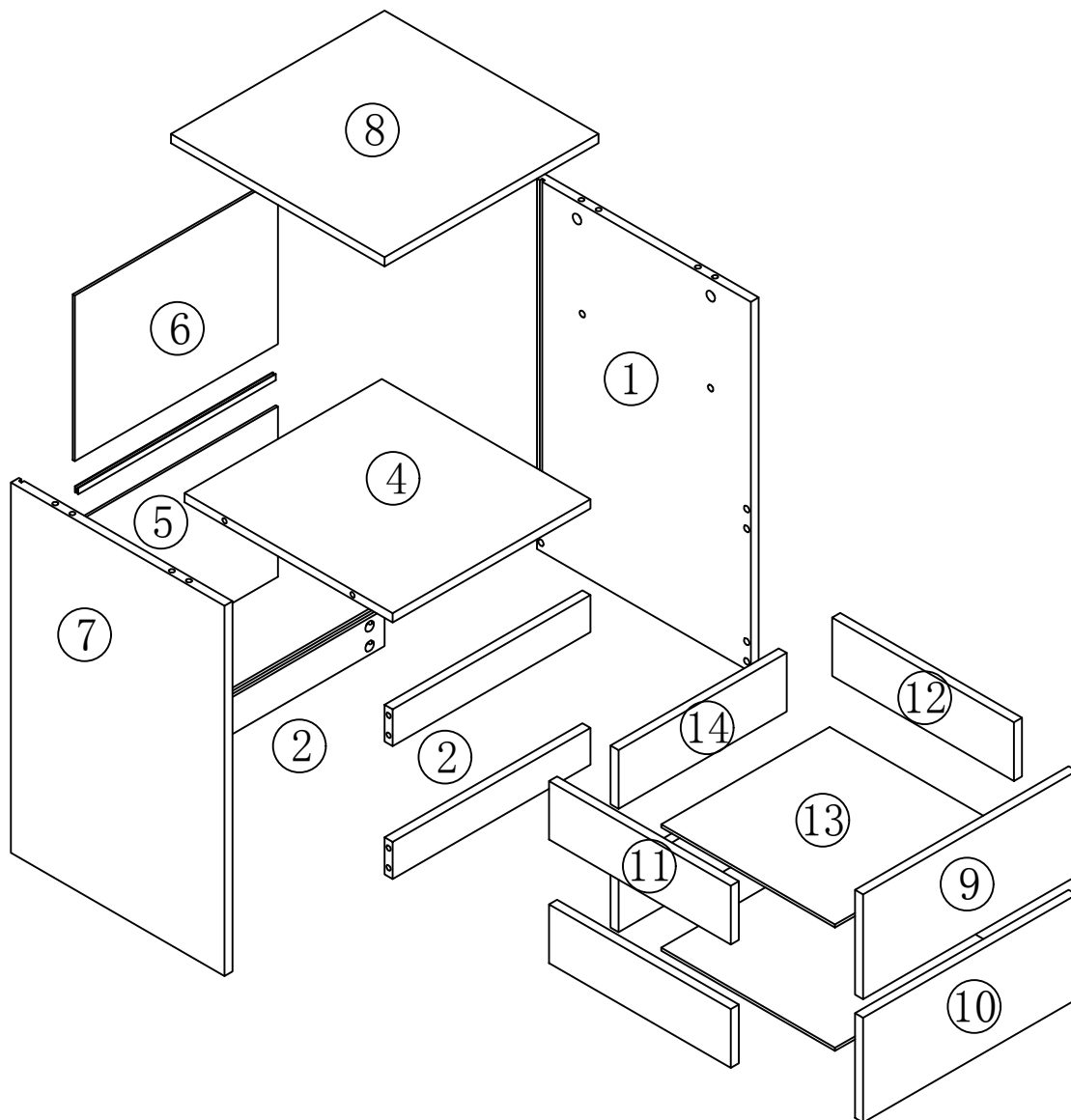
There is an number sticker on each wooden Panel. Please match them one by one according to the instructions.



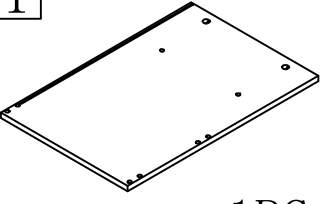
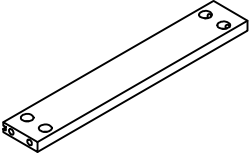
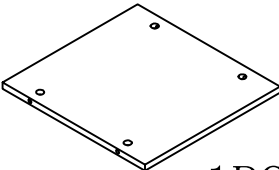
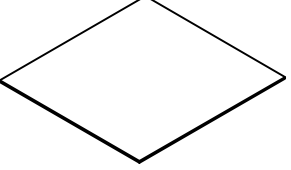
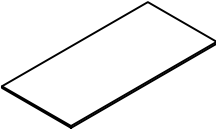
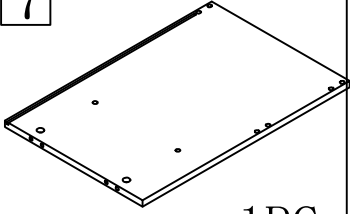
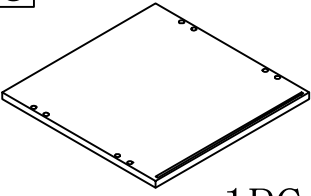
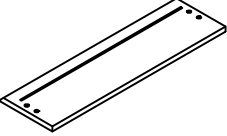
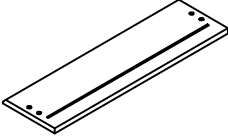
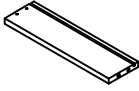
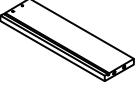
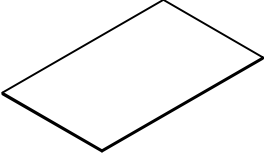

The letter in the top-left corner indicates the parts bag number, with the adjacent number showing the included quantity. Bottom text specifies product dimensions. Before installation, please verify all parts. For missing/damaged items, contact us - we'll promptly supply replacements.

<p>1</p>  <p>1PC</p>	<p>2</p>  <p>3PCS</p>	<p>4</p>  <p>1PC</p>	<p>5</p>  <p>1PC</p>
<p>6</p>  <p>1PC</p>	<p>7</p>  <p>1PC</p>	<p>8</p>  <p>1PC</p>	<p>9</p>  <p>1PC</p>
<p>10</p>  <p>1PC</p>	<p>11</p>  <p>2PCS</p>	<p>12</p>  <p>2PCS</p>	<p>13</p>  <p>2PCS</p>
<p>14</p>  <p>2PCS</p>			

- 1 Install the connector bolts in the pre-drilled holes of panels 1, 7, 8, 9, and 10.

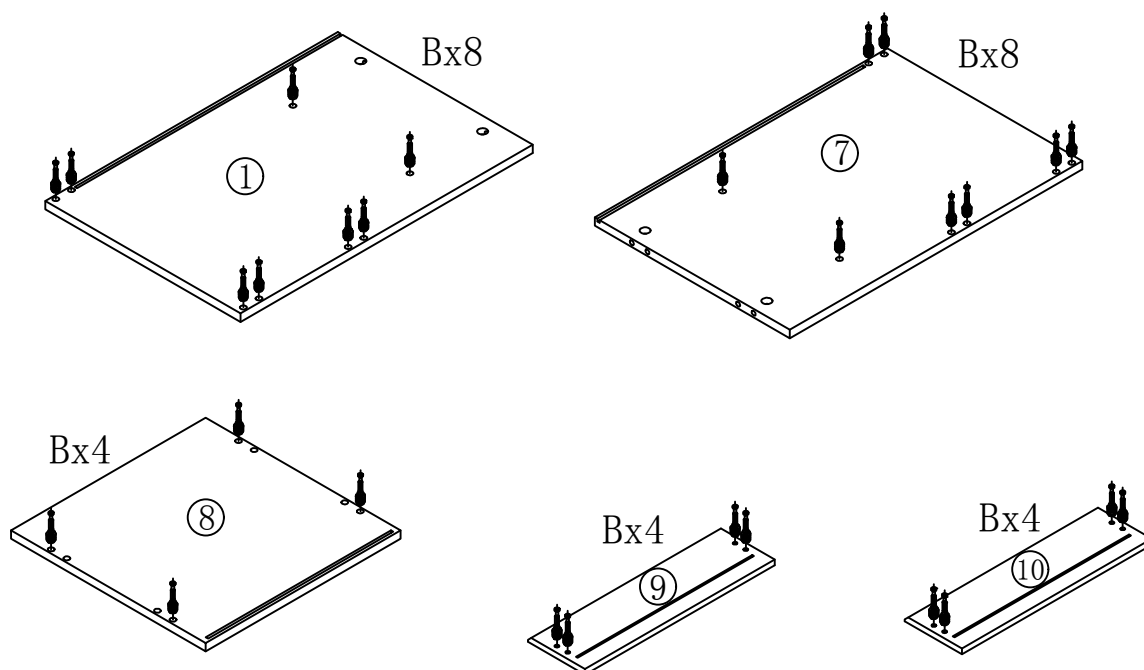
Tip: Use a hand screwdriver here to control depth and prevent over-drilling.



B	28PCS
	
Ø6*35mm	

- 2 Separate the drawer slide into two components: the K<sub>1</sub> (outer rail) and the K<sub>2</sub> (inner rail).

Tip: Bend and hold the rubber strip aside while pulling out the inner rail to separate the outer rail.

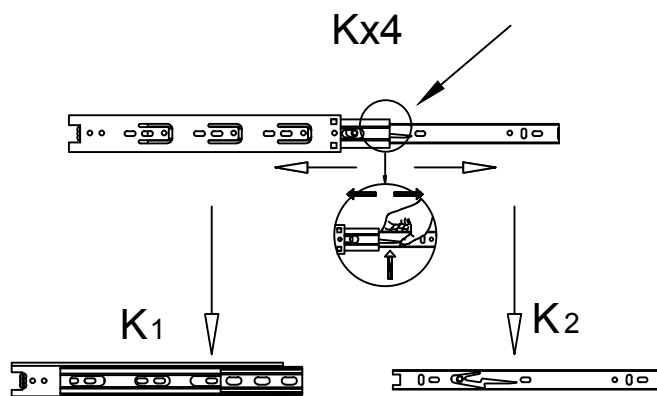

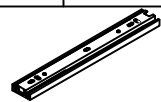
K	4PCS
	
10"	

3 Secure the #K<sub>1</sub> (outer rails) to the pre-drilled holes on Panel 1 and Panel 7 using #F (screws).

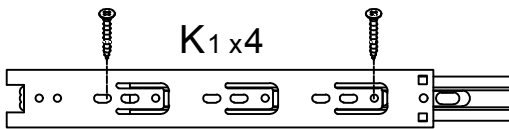
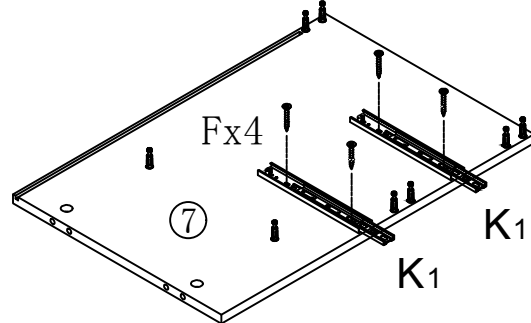
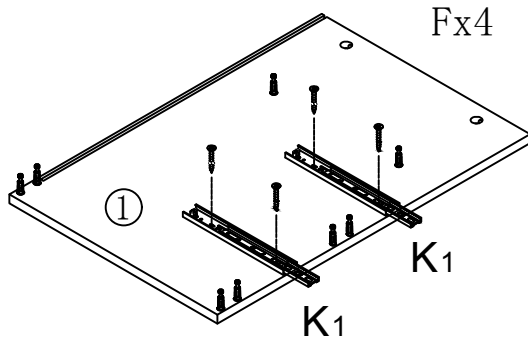

F	8PCS
	
Ø3.5*14mm	

K <sub>1</sub>	4PCS
	
10"	

4 Assemble Panels 2 and 4 with Panel 1, then install and tighten the #A (eccentric cam lock).

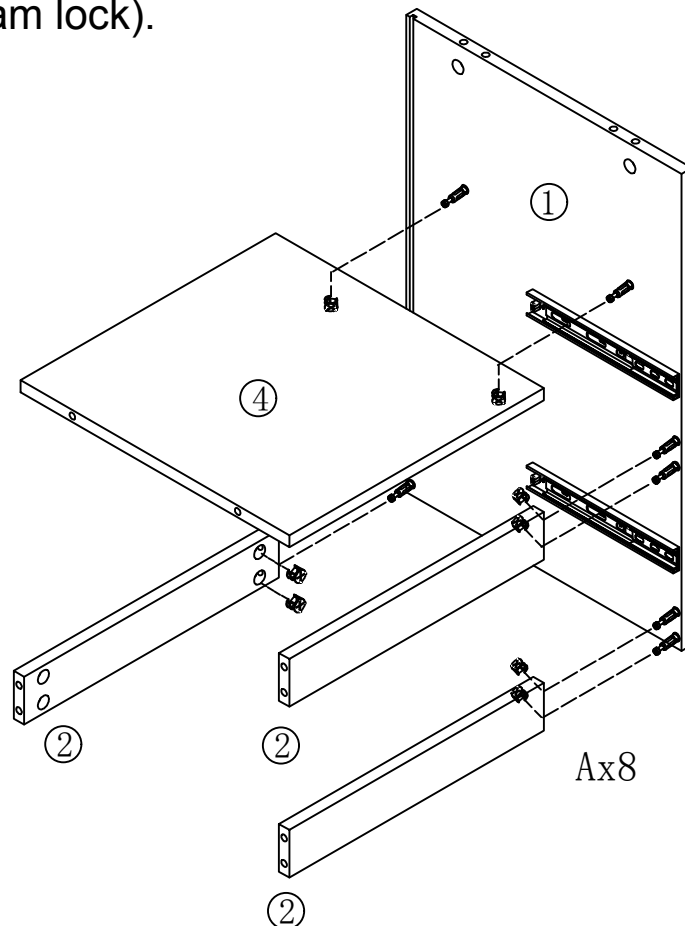

A	8PCS
	
Ø15*10mm	

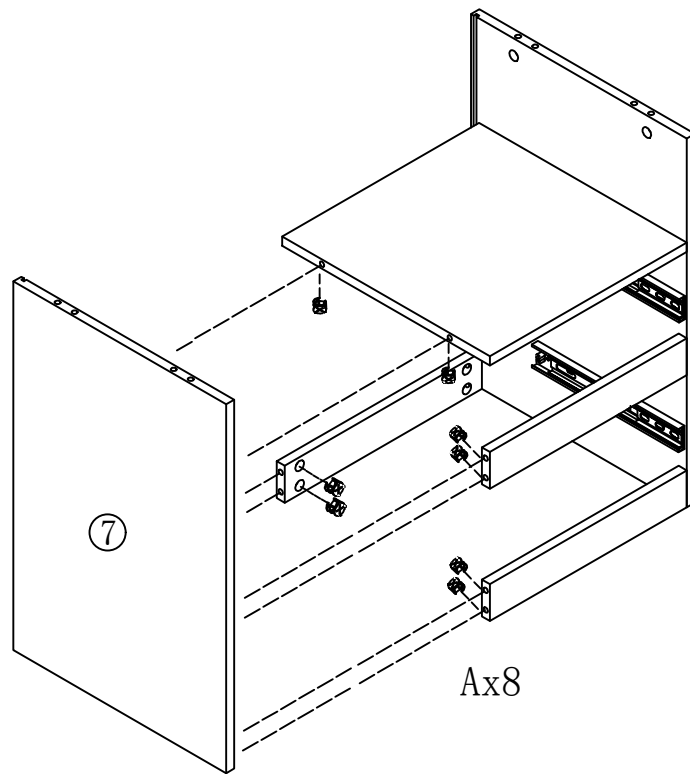

- 5 Install Panel 7 onto the assembly, then install and tighten #A (eccentric cam lock).

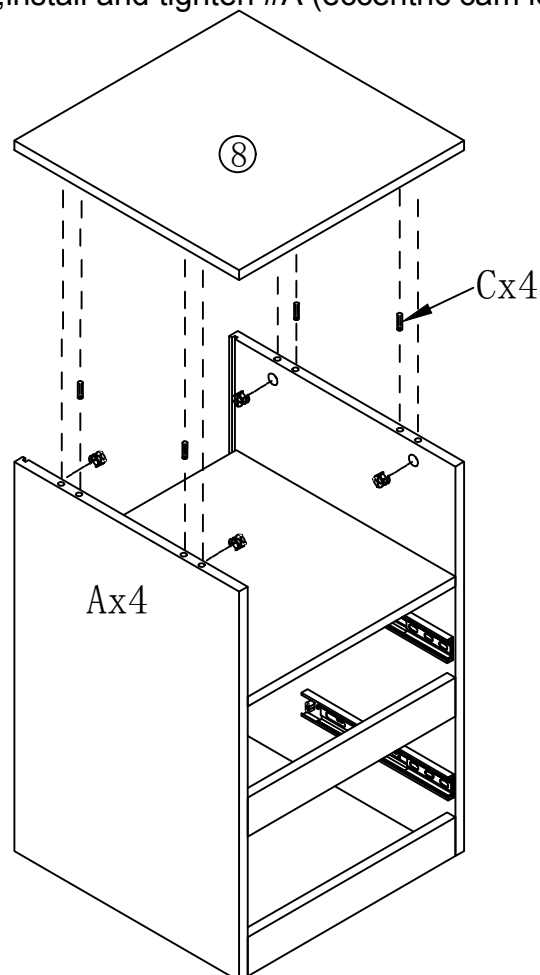

A	8PCS
	
Ø15*10mm	

- 6 First, insert #C(wood dowel pins)into the holes on the top of the assembly. Then, assemble Panel 8 onto it, and finally, install and tighten #A (eccentric cam lock) to complete the fixation.



A	4PCS	C	4PCS
			
Ø15*10mm		Ø8*30mm	

**7** Install Panel 6, then Part #L, and finally Panel 5 to the back of the drawer cabinet.

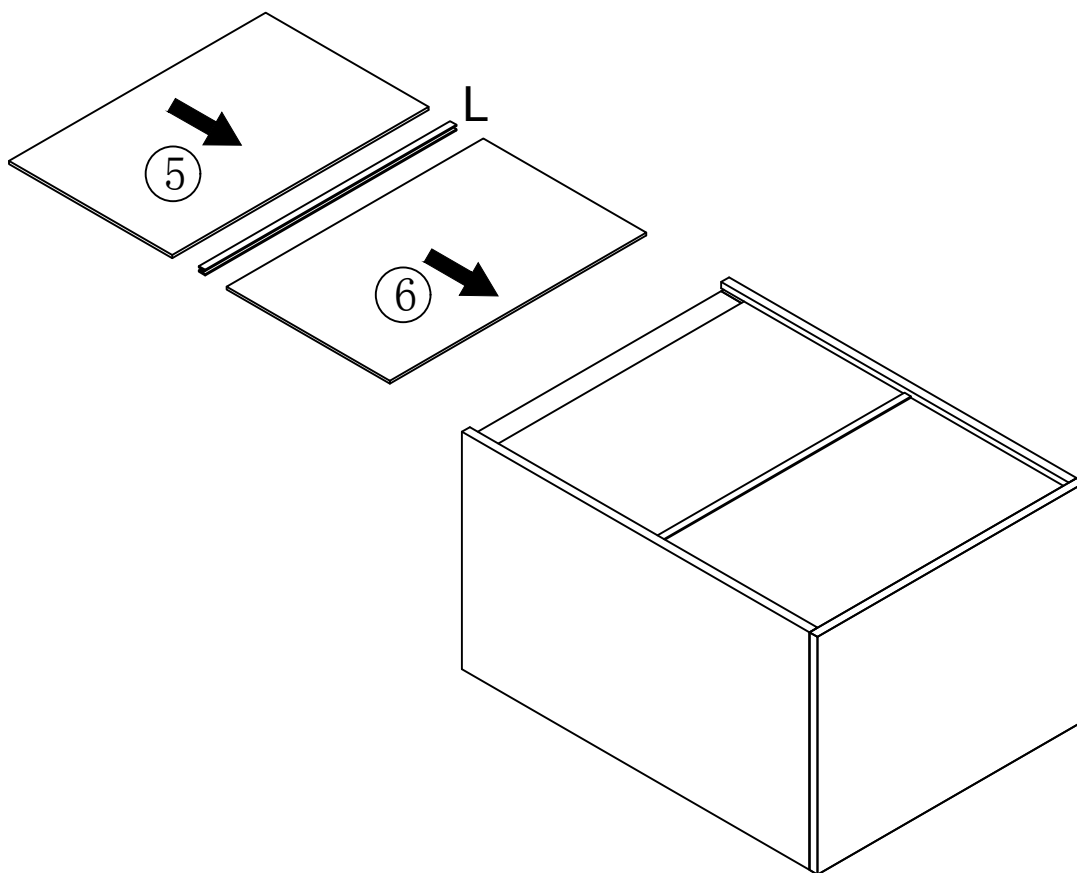

L	1PC

**8** Assemble two drawers :  
As shown in the diagram, first use #E (screws) to assemble Panel 11, Panel 12, and Panel 14 together (Note: the grooves of Panel 11 and Panel 12 should face downward and be opposite each other). Then, snap Panel 13 (the drawer base) into place.

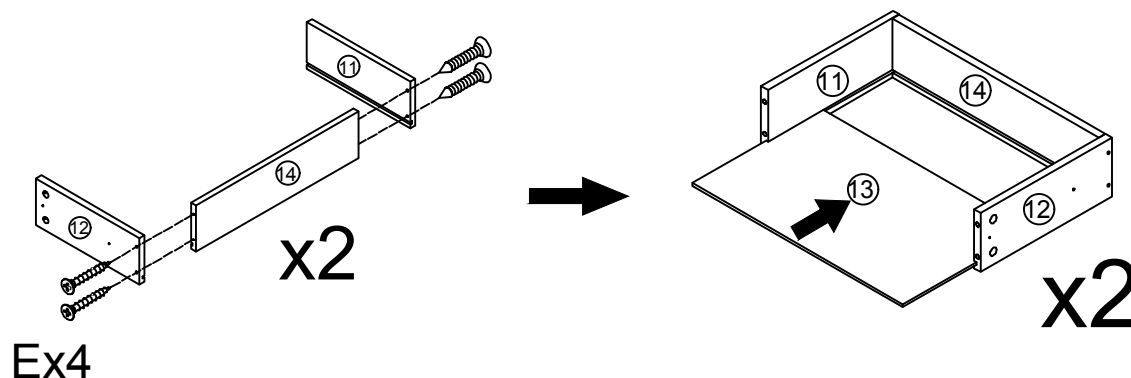

E	8PCS
Ø3.5*35mm	

9 After assembling Panel 9 and Panel 10 with the drawer component, install and tighten #A (eccentric cam lock) to complete the fixation.

Upper drawer: Panel #9  
beveled edge faces downward

Lower drawer: Panel #10  
beveled edge faces upward

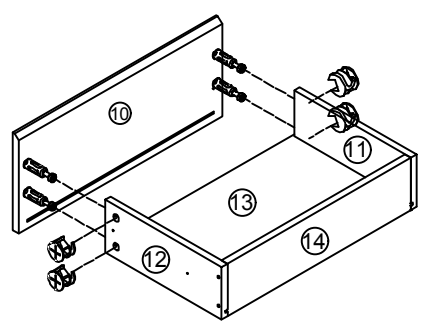
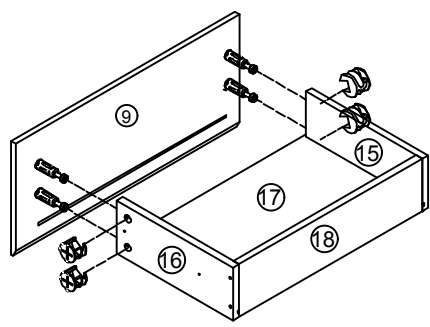

A	8PCS
Ø15*10mm	

10 Use #F (screws) to attach K<sub>2</sub> (inner rail) to both sides of each drawer.

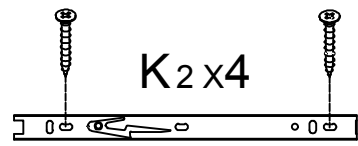
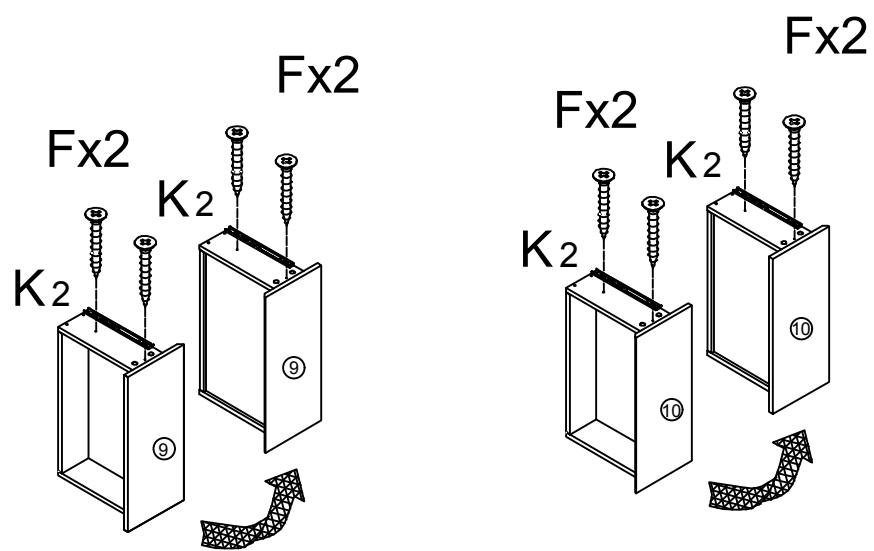

F	8PCS
Ø3.5*14mm	

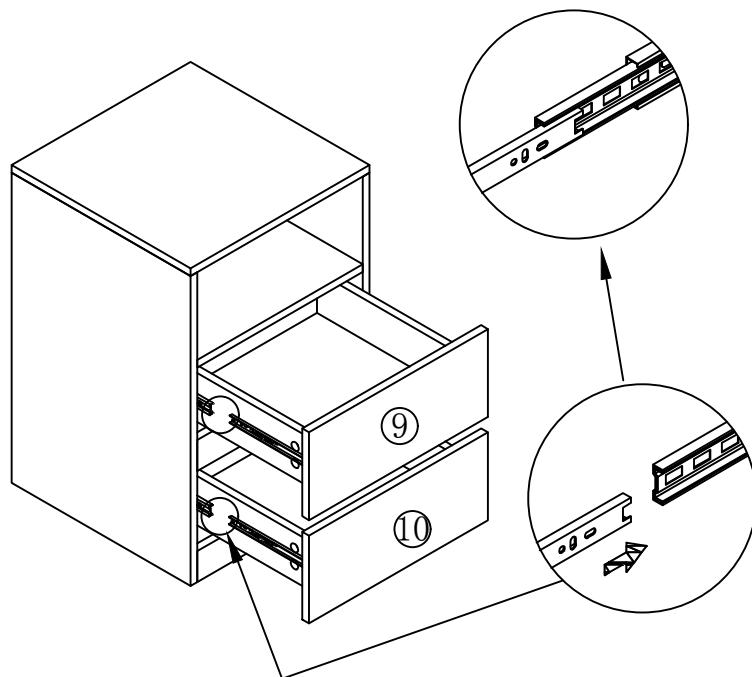

K <sub>2</sub>	4PCS
10"	

11 Align drawer K<sub>2</sub> (inner rail) with cabinet K<sub>1</sub> (outer rail) mounts and engage.

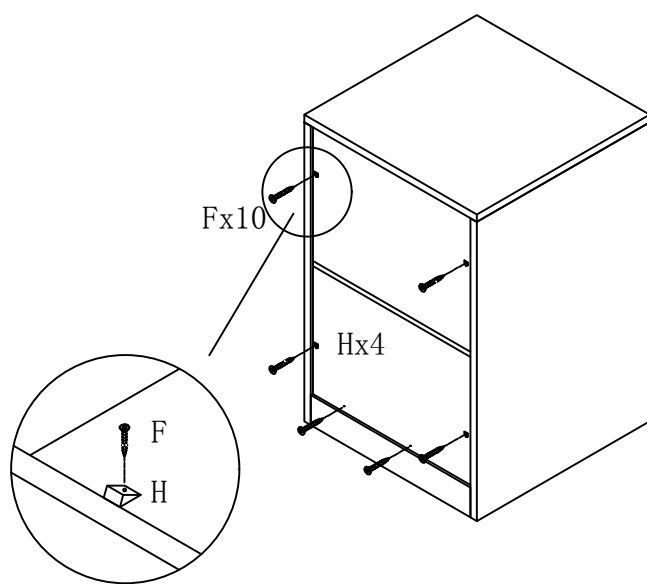

12 Secure back panel by installing #F and #H to drawer cabinet rear.



<b>F</b>	10PCS	<b>H</b>	4PCS
			
Ø3.5*14mm			

**13** Install #D (decorative stickers) over the pre-drilled holes in the open storage area to conceal the fasteners.

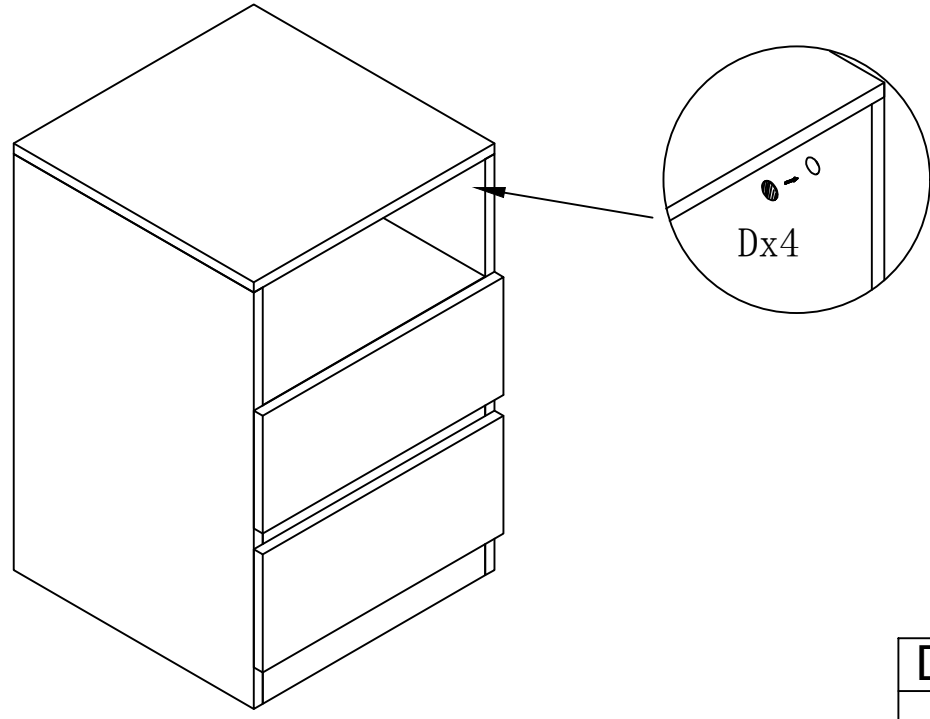

<b>D</b>	4PCS

**14** Installation Complete!

