

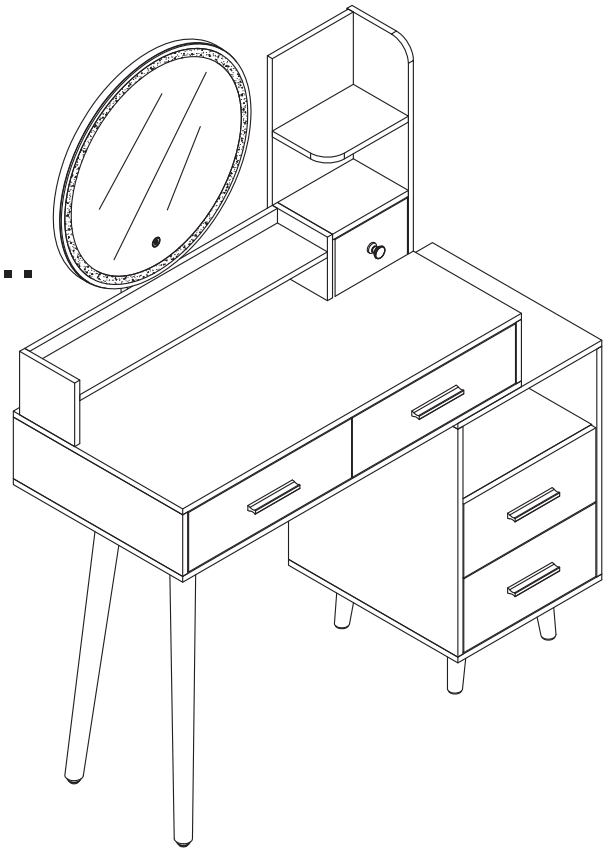

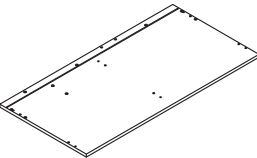

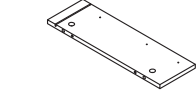

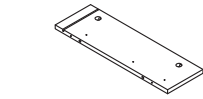

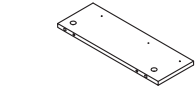
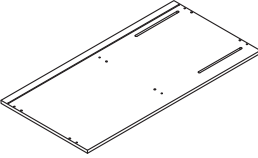
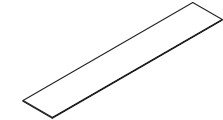
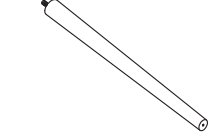
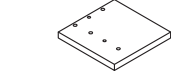
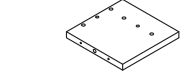
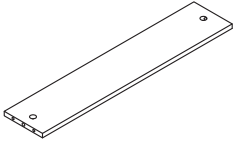
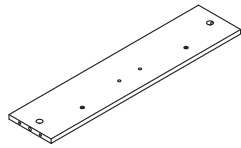
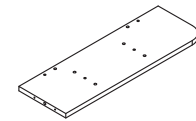
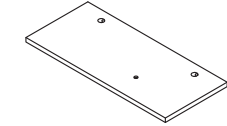
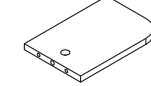
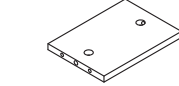
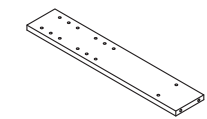

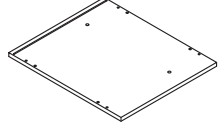
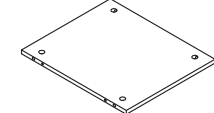
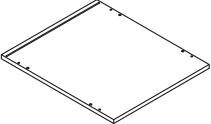
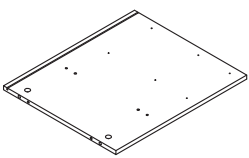
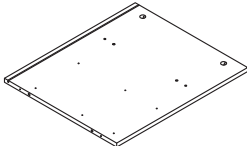
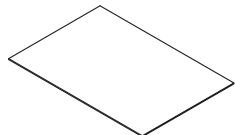

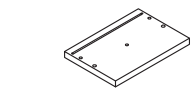
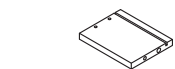

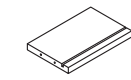
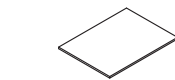
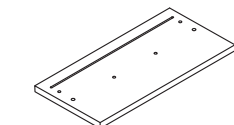
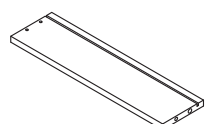
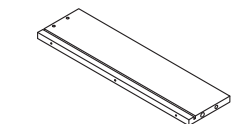
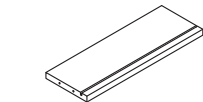
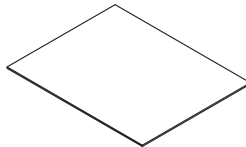
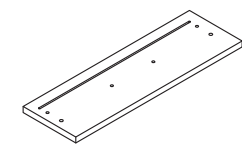
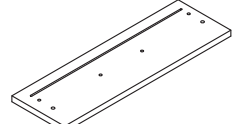
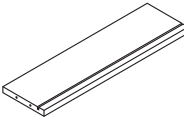
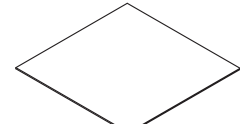

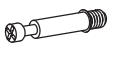



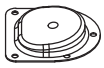









Between..

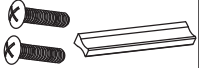

If parts are missing, contact us to obtain any missing parts.

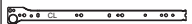
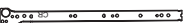

① x1 	② x1 	③ x1 	④ x1 	⑤ x1 
⑥ x1 	⑦ x2 	⑧ x1 	⑨ x1 	⑩ x1 
⑪ x1 	⑫ x1 	⑬ x1 	⑭ x1 	⑮ x1 
⑯ x1 	⑰ x1 	⑱ x1 	⑲ x1 	⑳ x1 
㉑ x1 	㉒ x1 	㉓ x1 	㉔ x4 	㉕ x1 
㉖ x1 	㉗ x1 	㉘ x1 	㉙ x1 	㉚ x2 
㉛ x4 	㉜ x4 	㉝ x2 	㉞ x2 	㉟ x1 
㊳ x1 	㊴ x2 	㊵ x2 		

Hardware

A x43 +2(spare)  Ø6x35mm	B x43 +2(spare)  Ø15x10mm	C x48 +3(spare)  Ø6x30mm	D x42 +2(spare)  Ø4x40mm	E x48 +4(spare) 	F x6 
G x30 +2(spare) 	H x2 	I x4 	J x6 +1(spare)  	K x2  Ø6x18mm	L x2  Ø6x15mm
M x4 	N x2 	O x2  Ø6x40mm	P x1  M4mm	Q x6  Ø6x25mm	R x1  
S x4 	T x1 	U x1 U-1 U-2  Ø4x40mm	V x1 	W x1 	CL x4  L350mm
CR x4  L350mm	DL x4  L350mm	DR x4  L350mm			

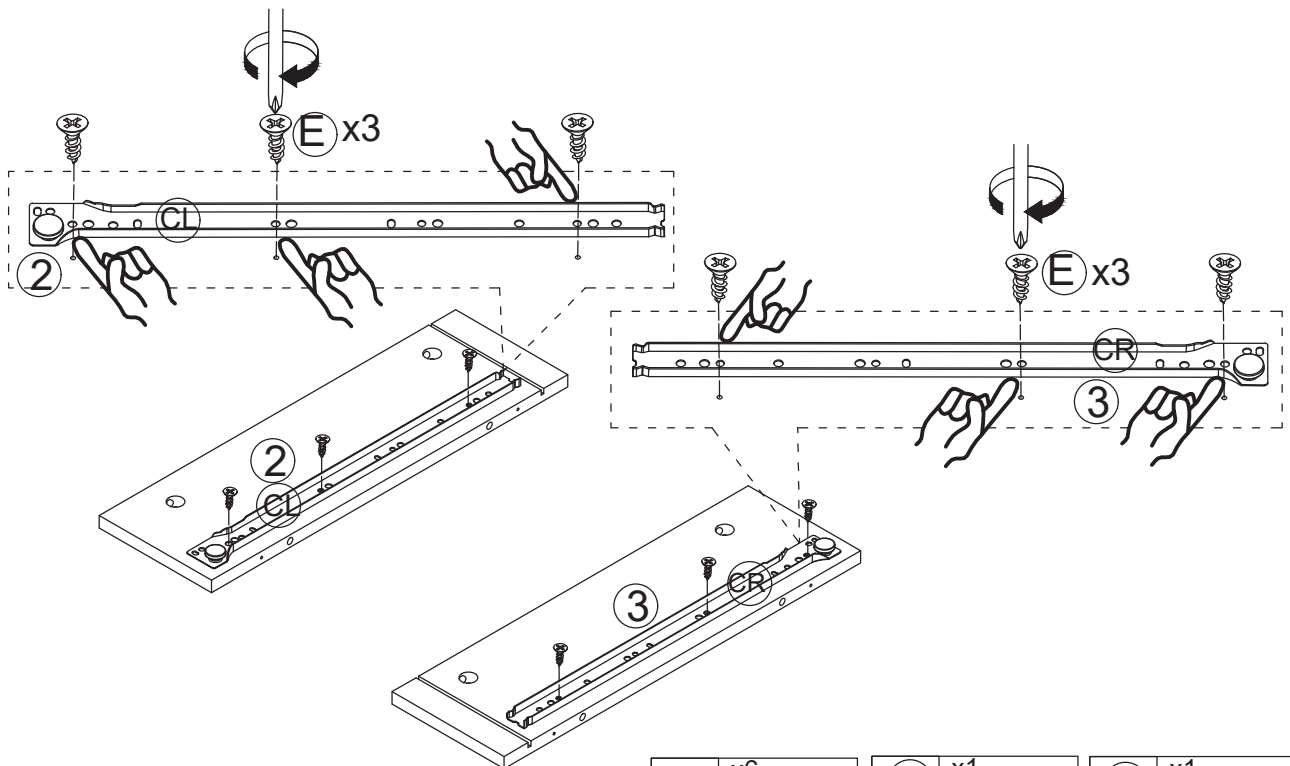
1

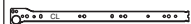

E x6 	CL x1  L350mm	CR x1  L350mm
--	---	---

2

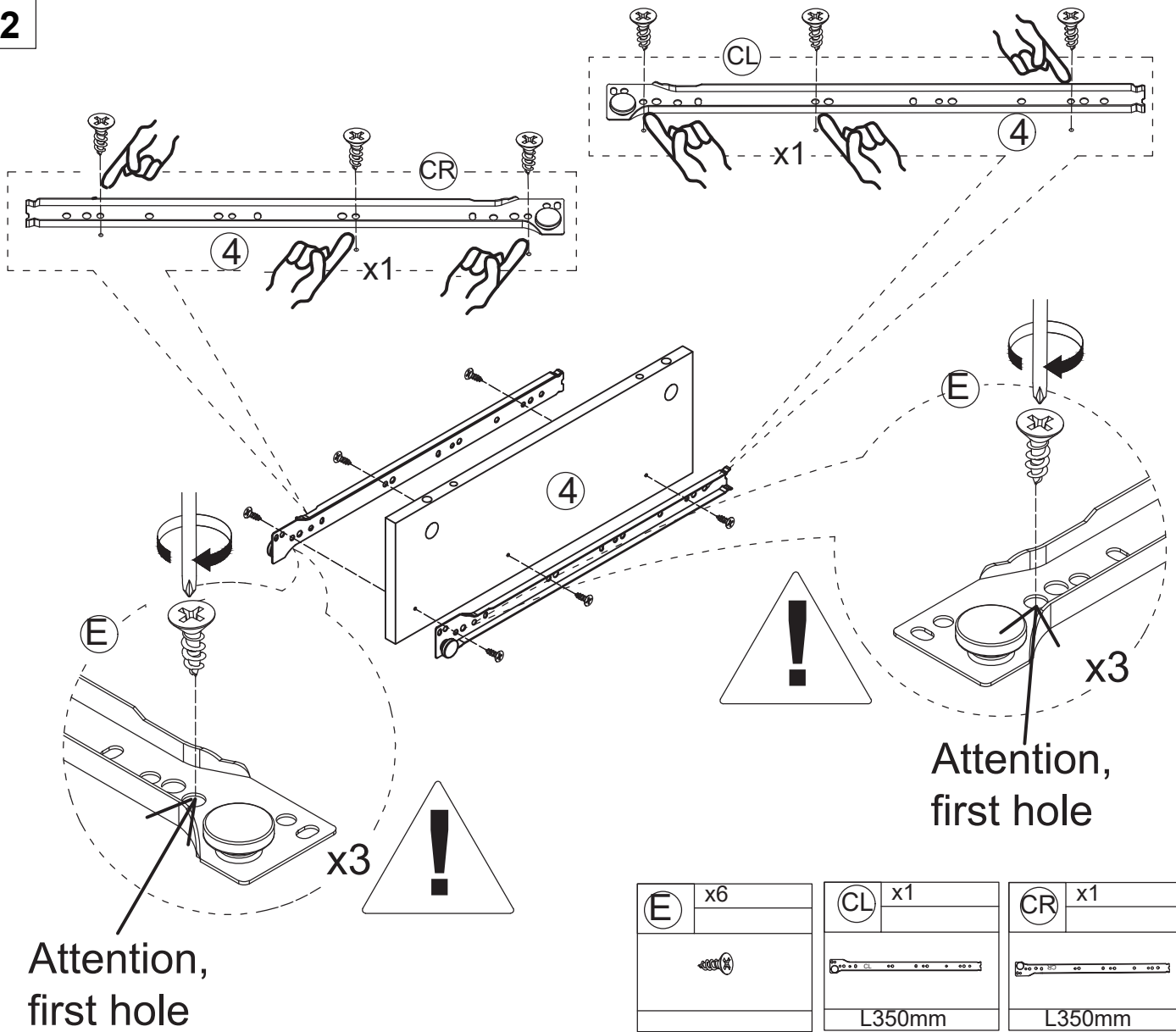

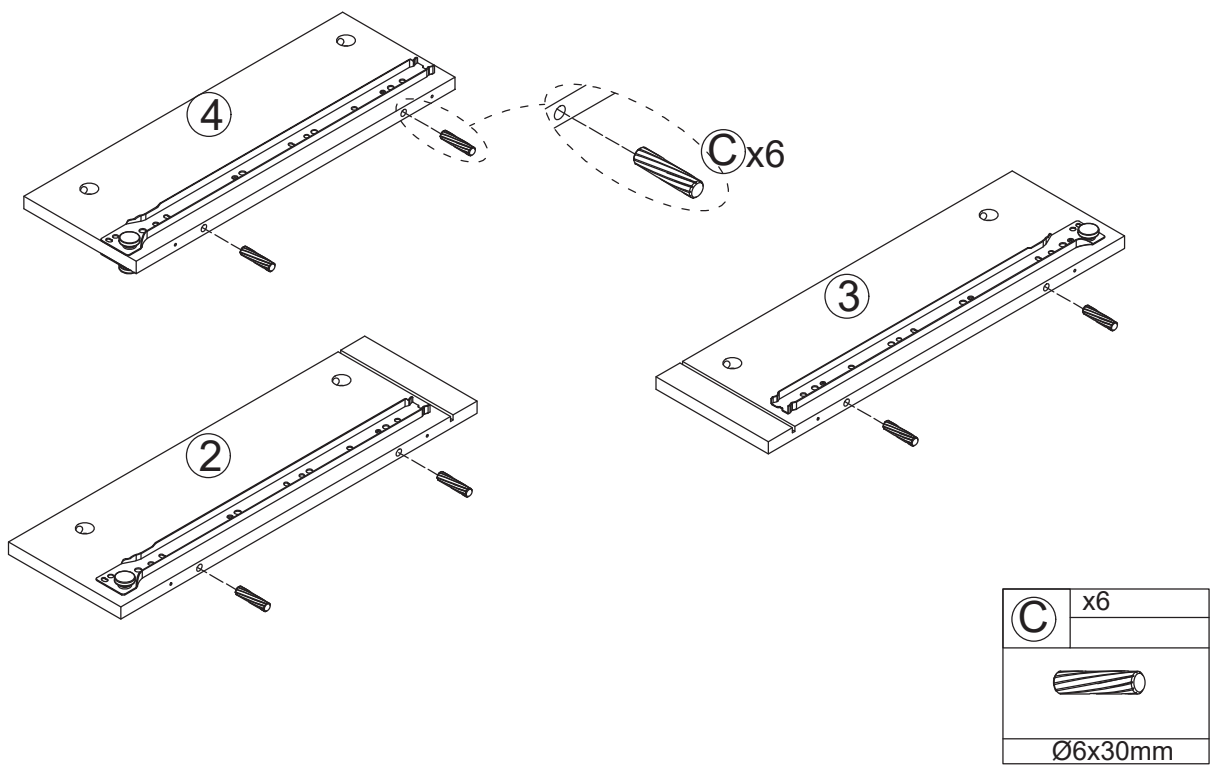

3



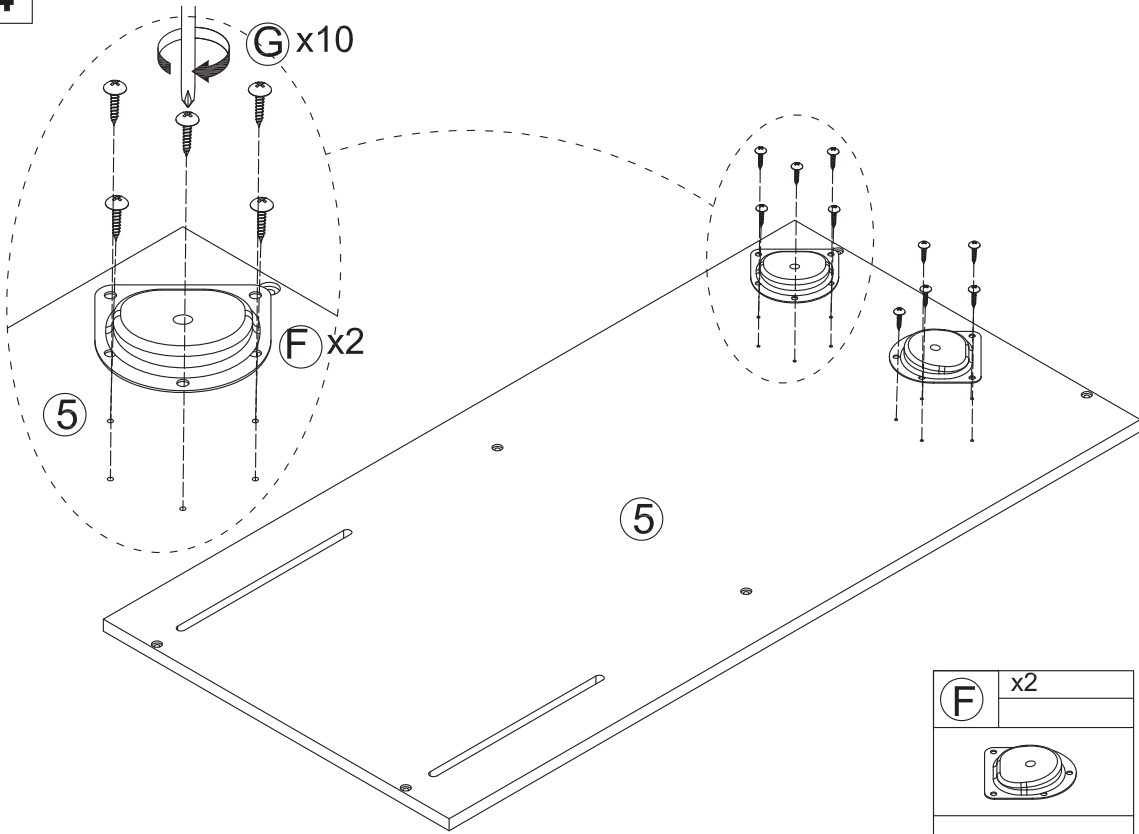

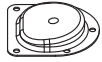
4

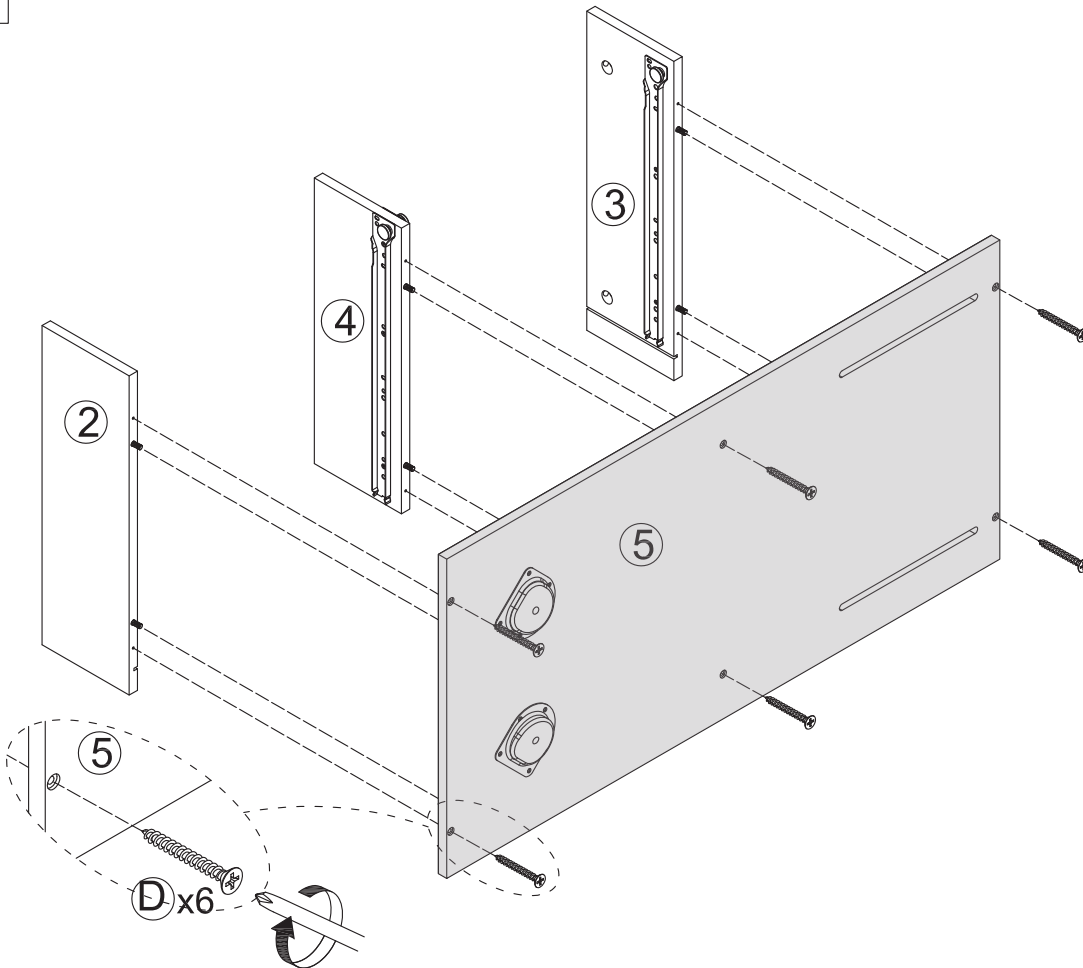

F	x2
	
G	x10
	

5



D	x6
	

6

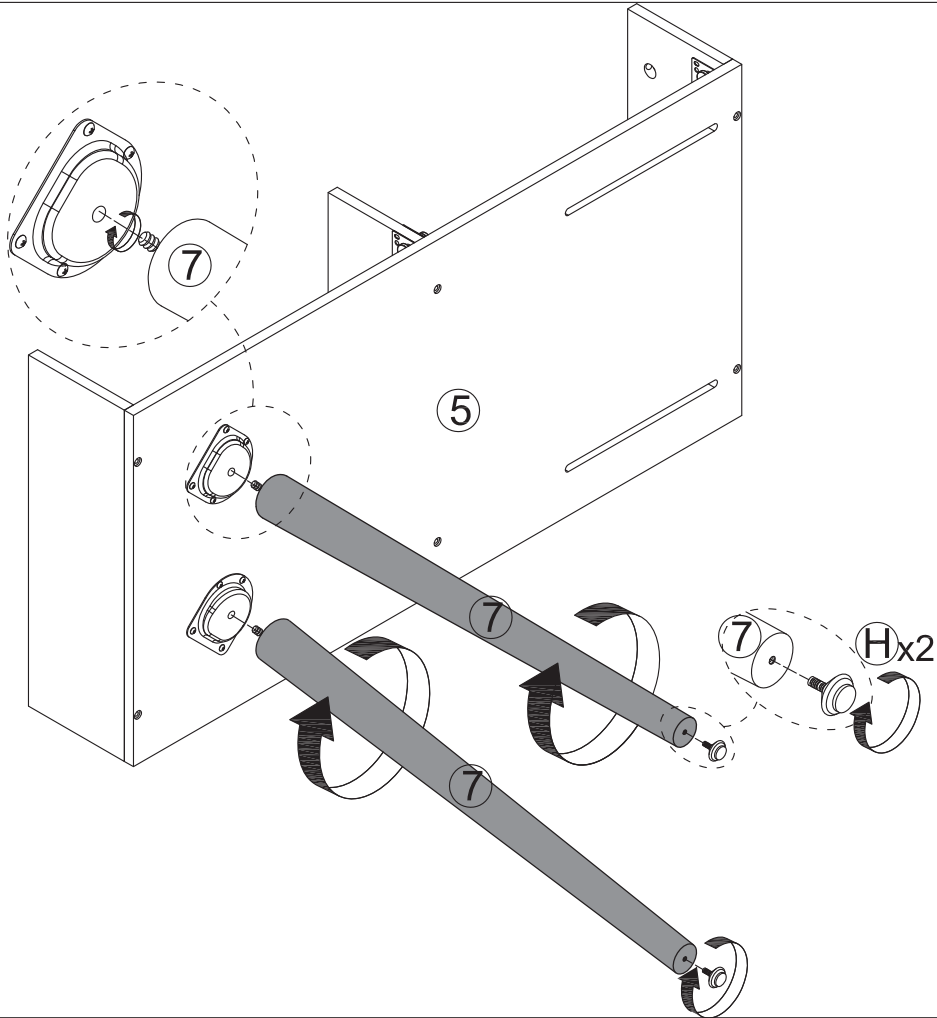

H	x2

7

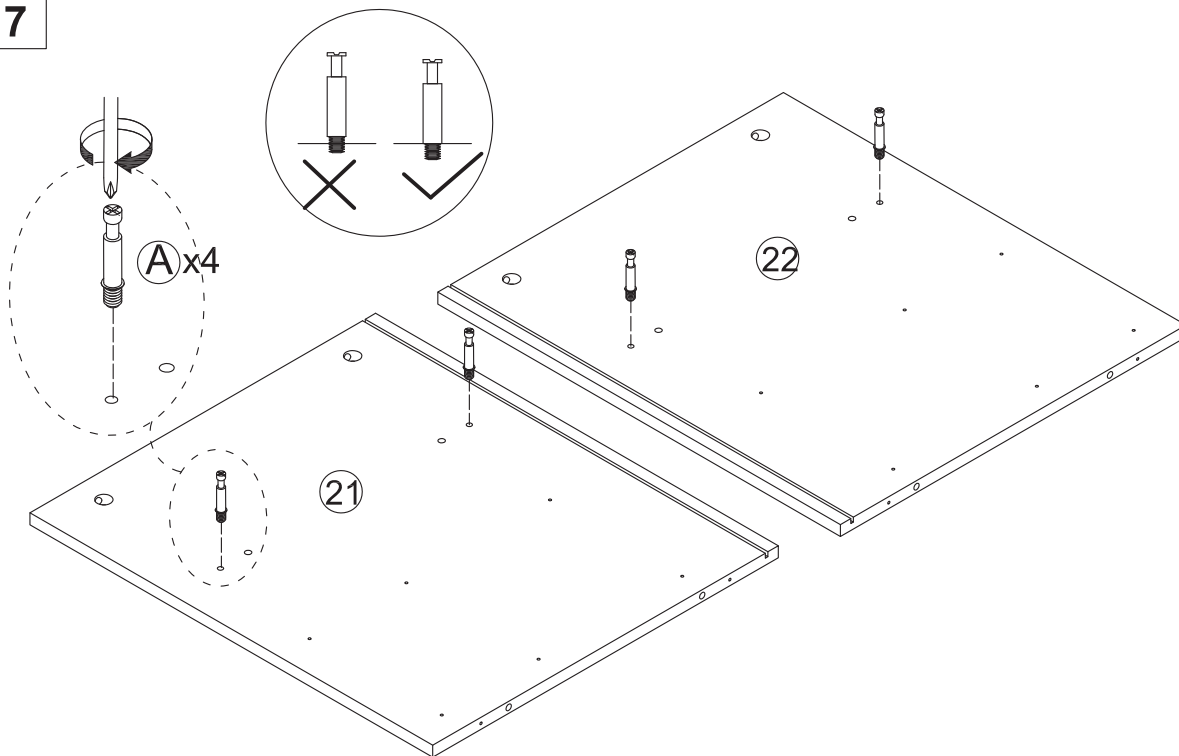

A	x4
Ø6x35mm	

8

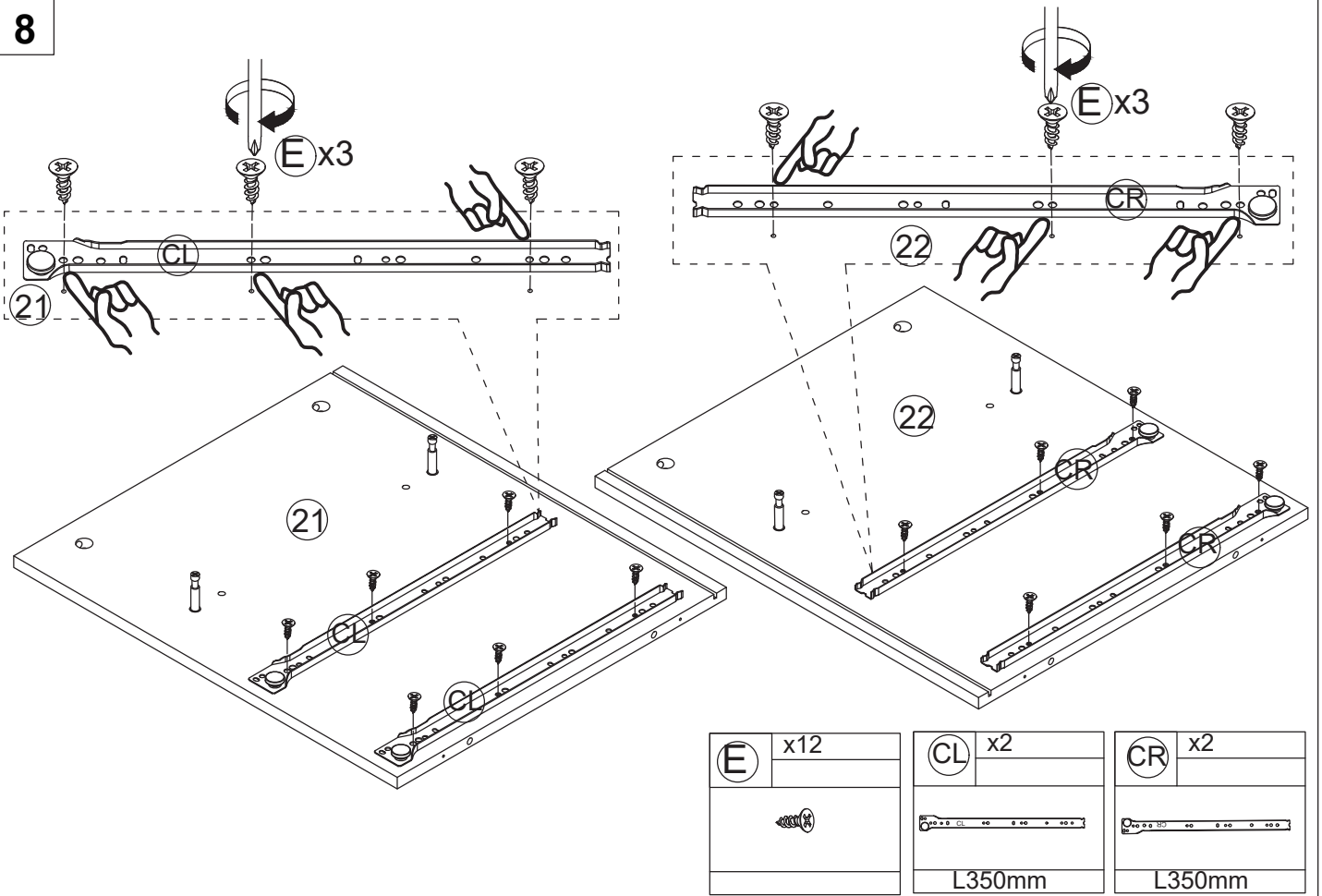

E	x12	CL	x2	CR	x2
		L350mm		L350mm	

9

! There is edge banding in front

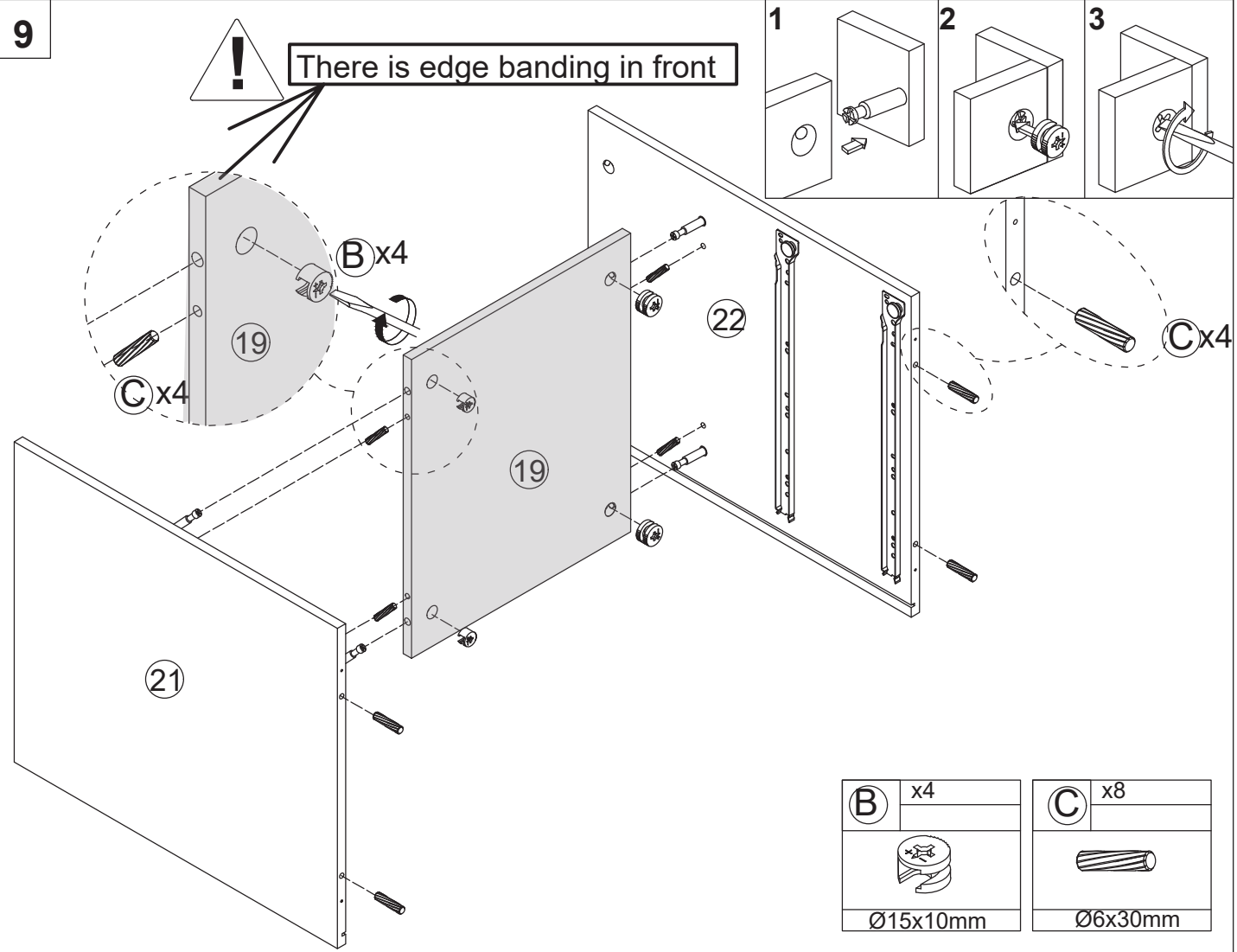
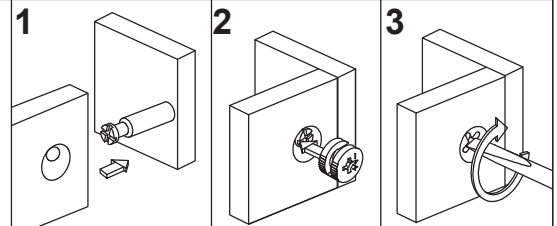

B	x4	C	x8
Ø15x10mm		Ø6x30mm	

10

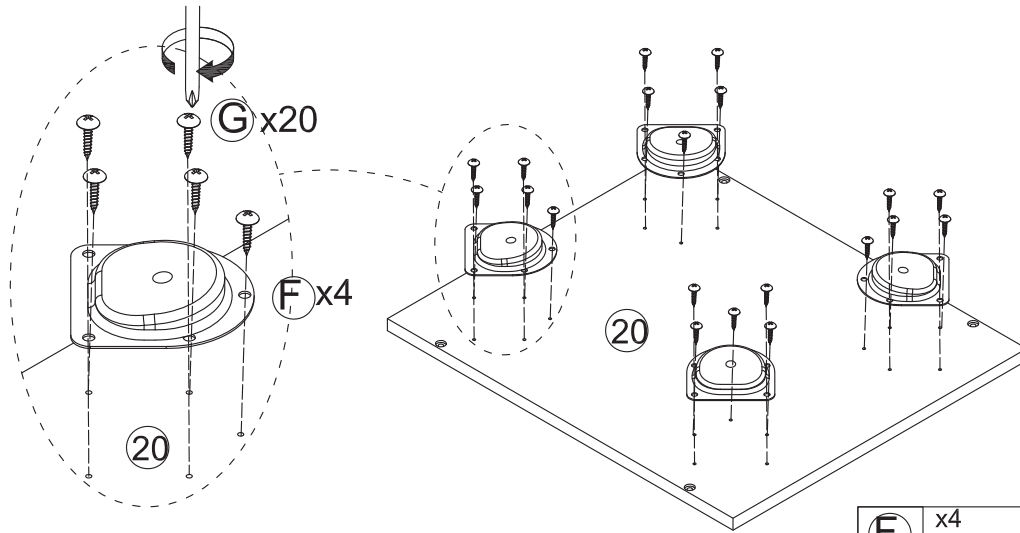

F	x4
	

G	x20
	

11

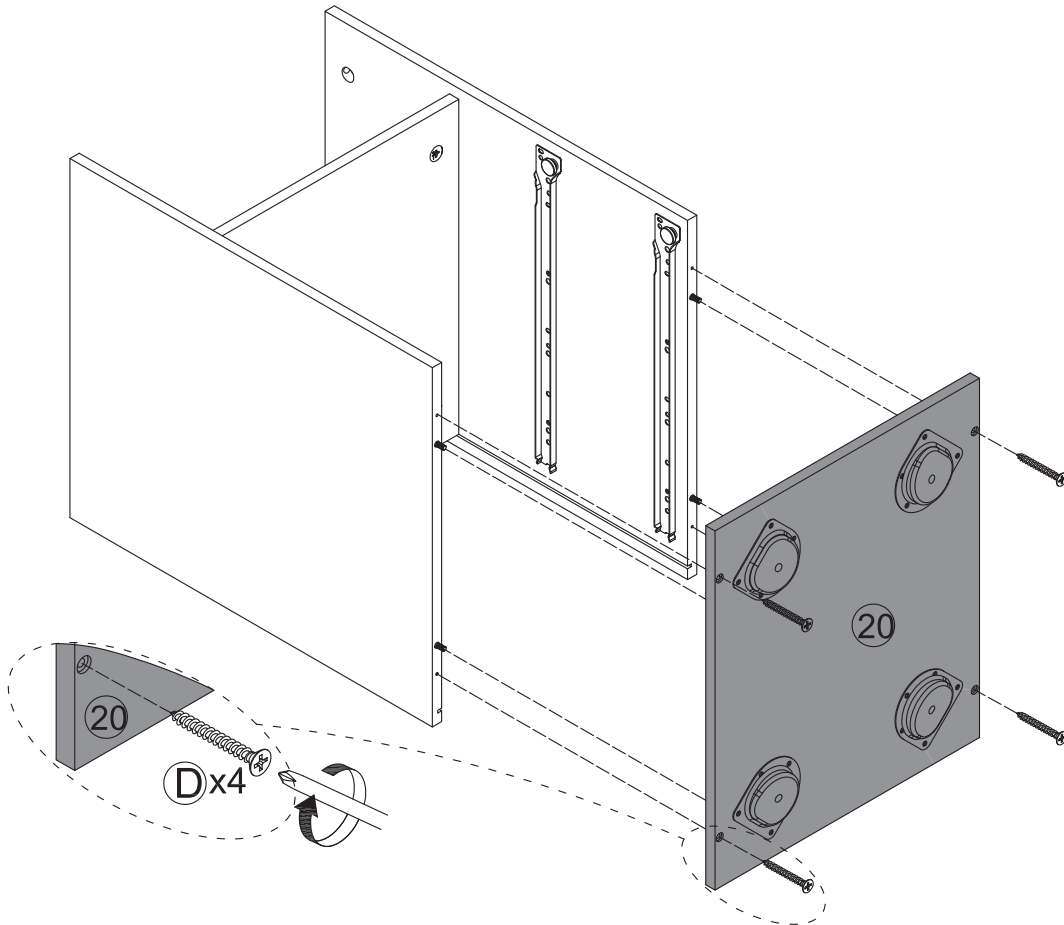

D	x4
	

12

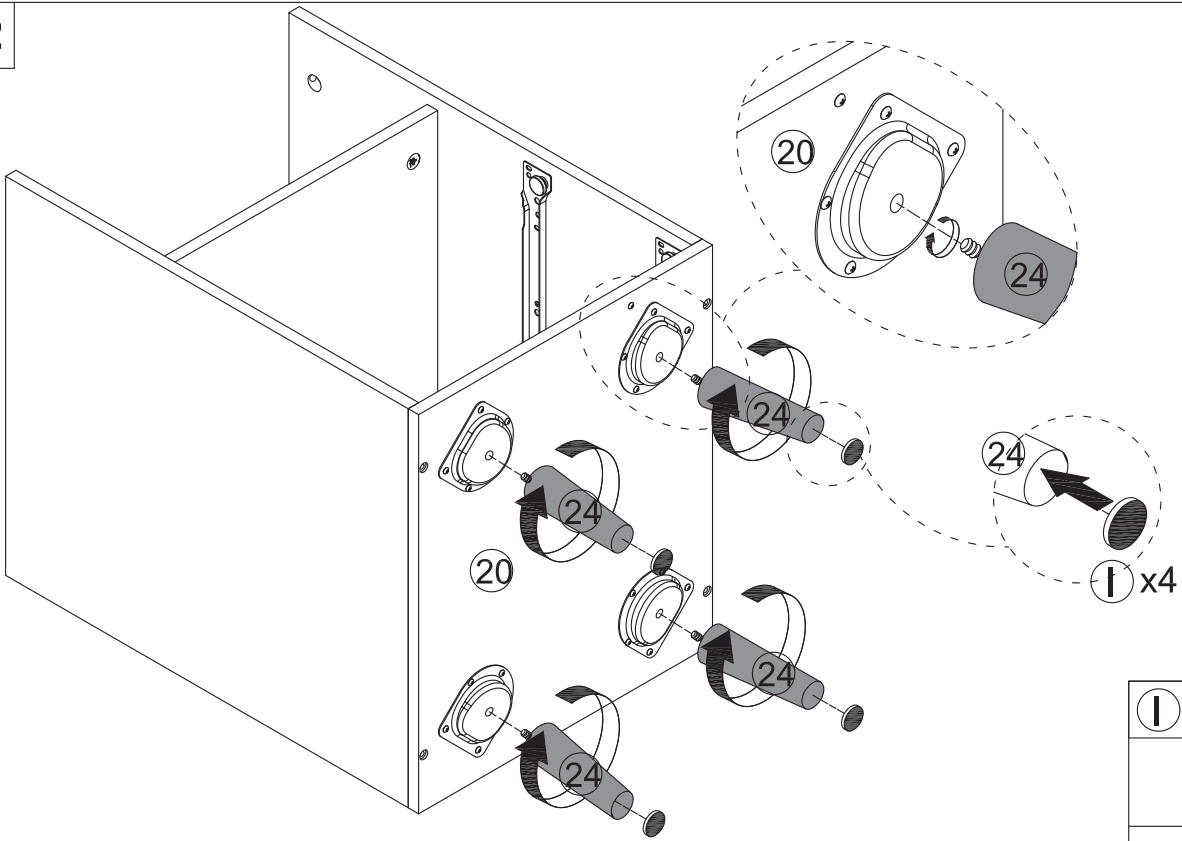

⊥	x4

13

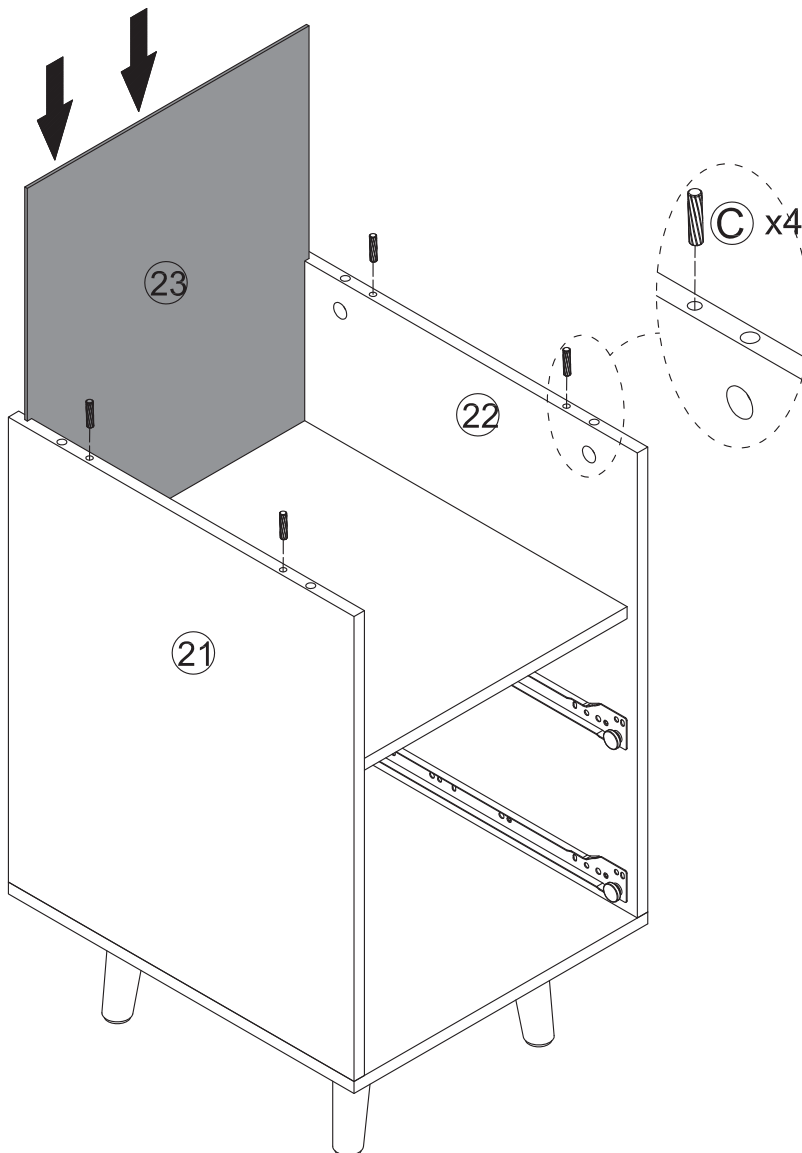

C	x4
Ø6x30mm	

14

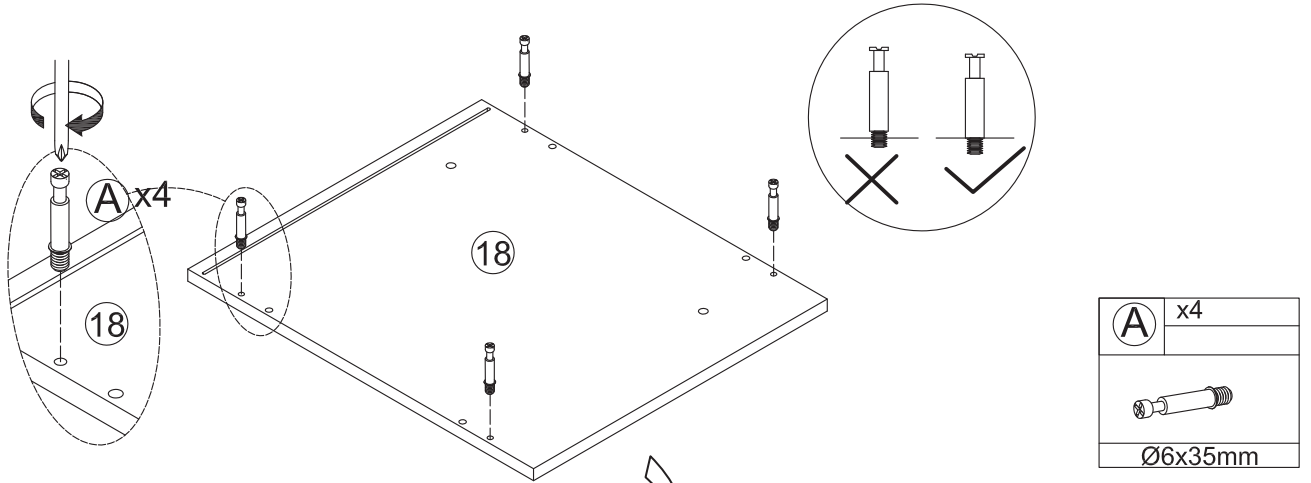

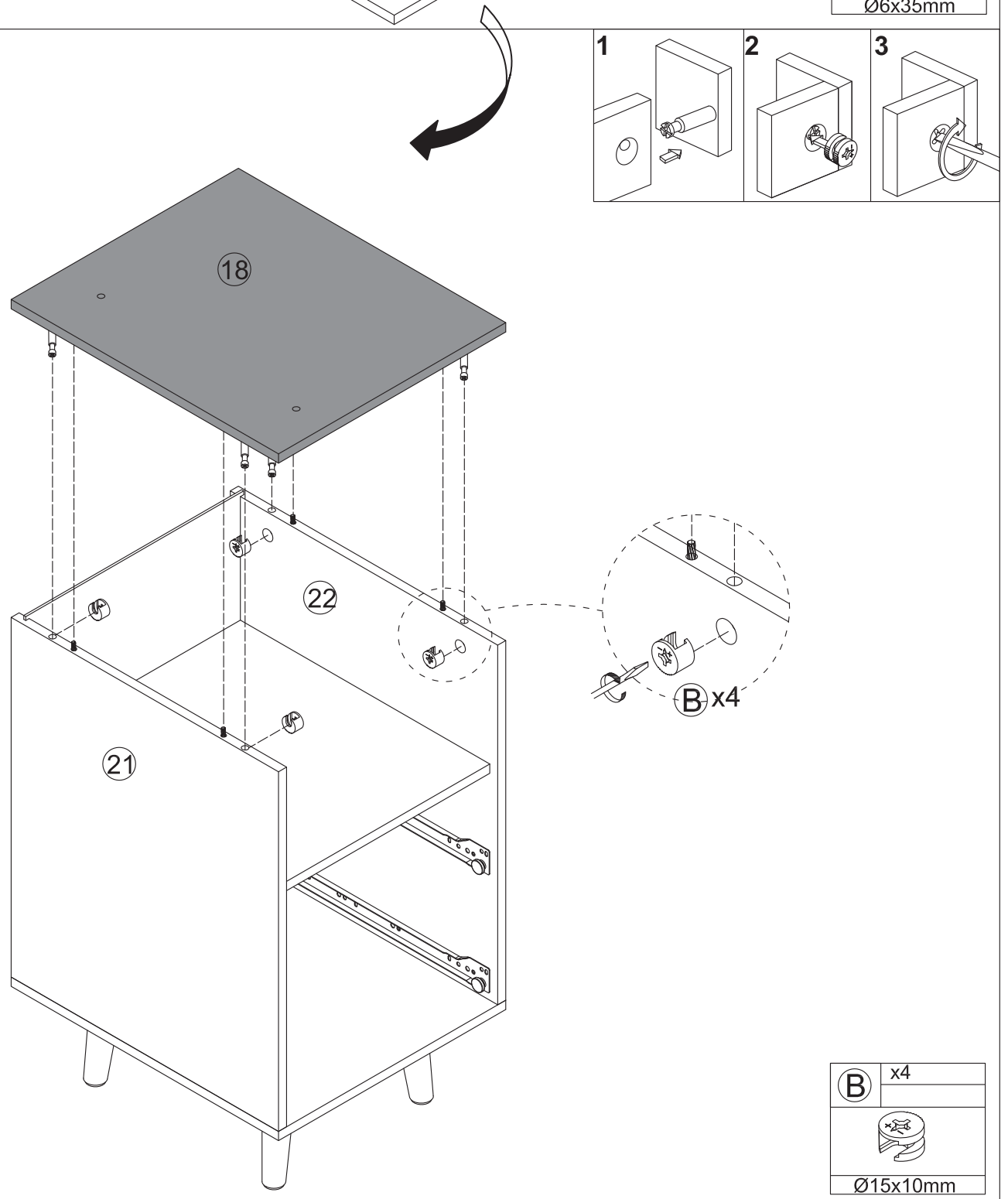

15

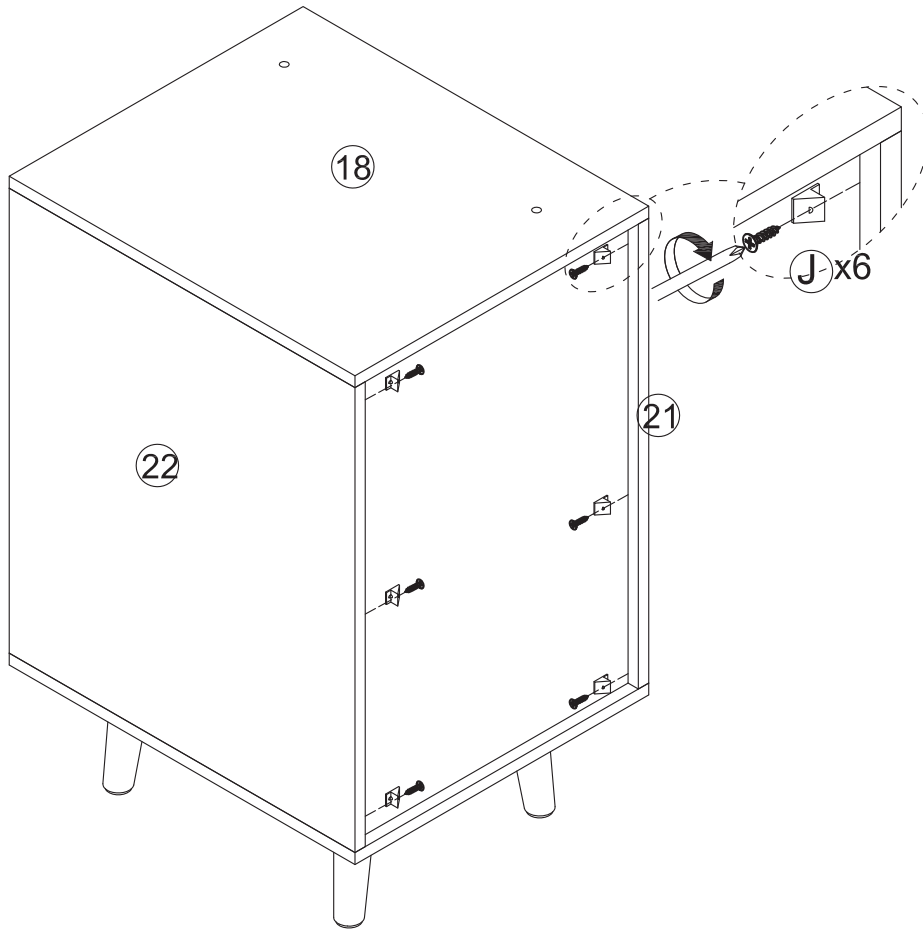

16





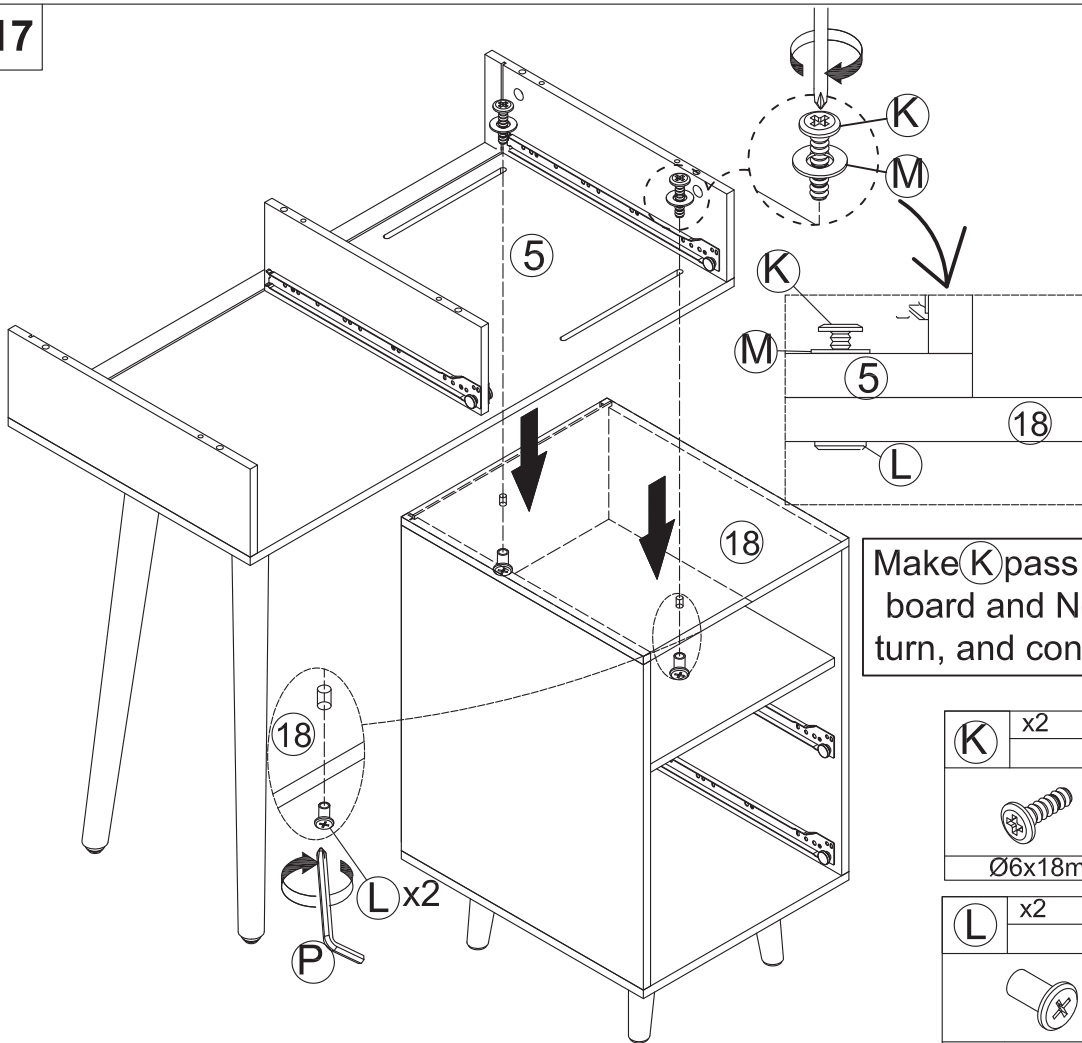

J	x6
	

17

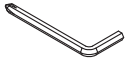
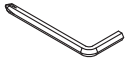
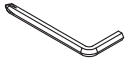

Make **K** pass through **M**, No. 5 board and No. 18 board in turn, and connect with **L**.

K	x2	P	x1
			
Ø6x18mm	M4mm		
L	x2	M	x2
			
Ø6x15mm			

18

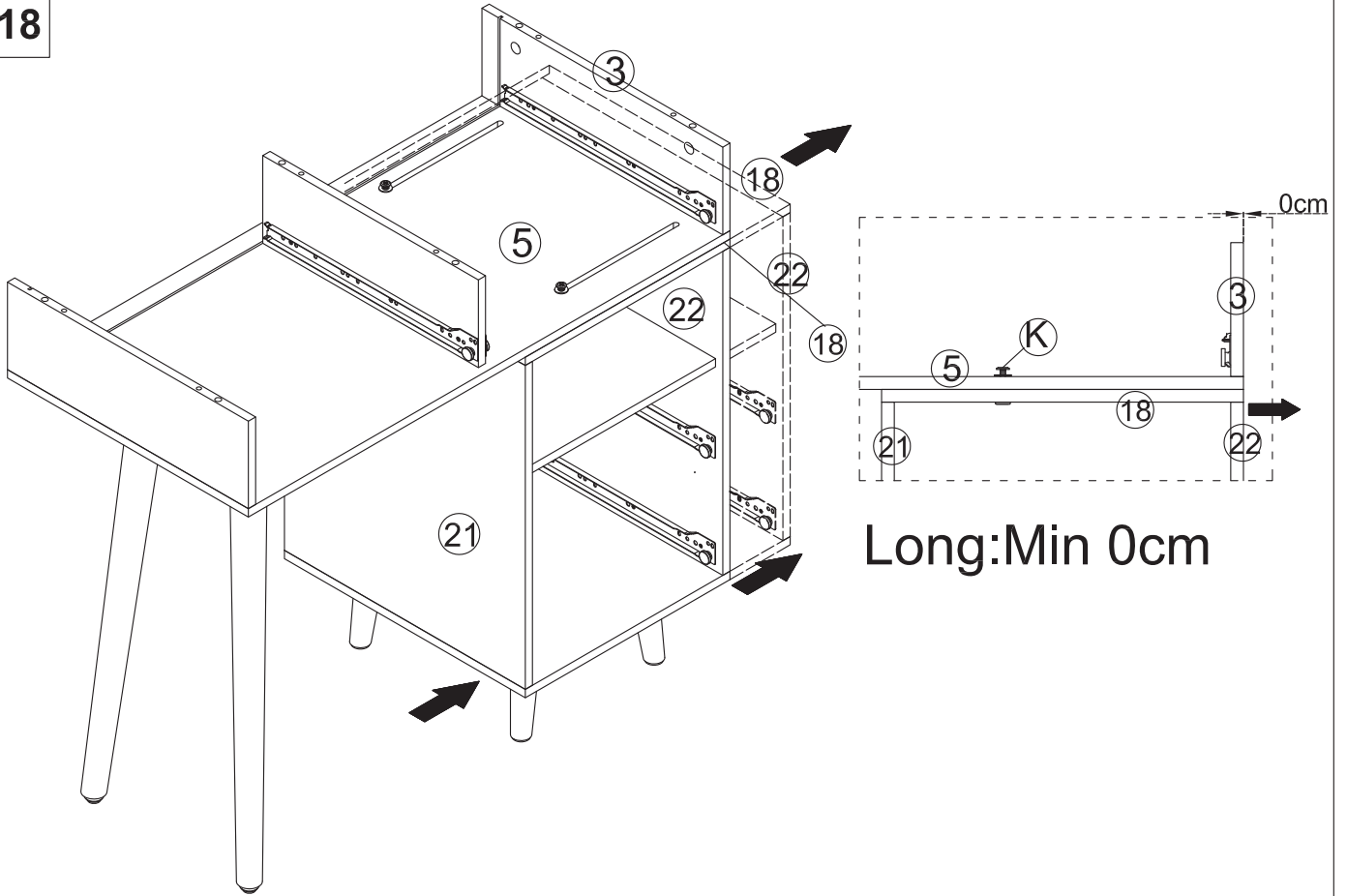

Long:Min 0cm

Between..

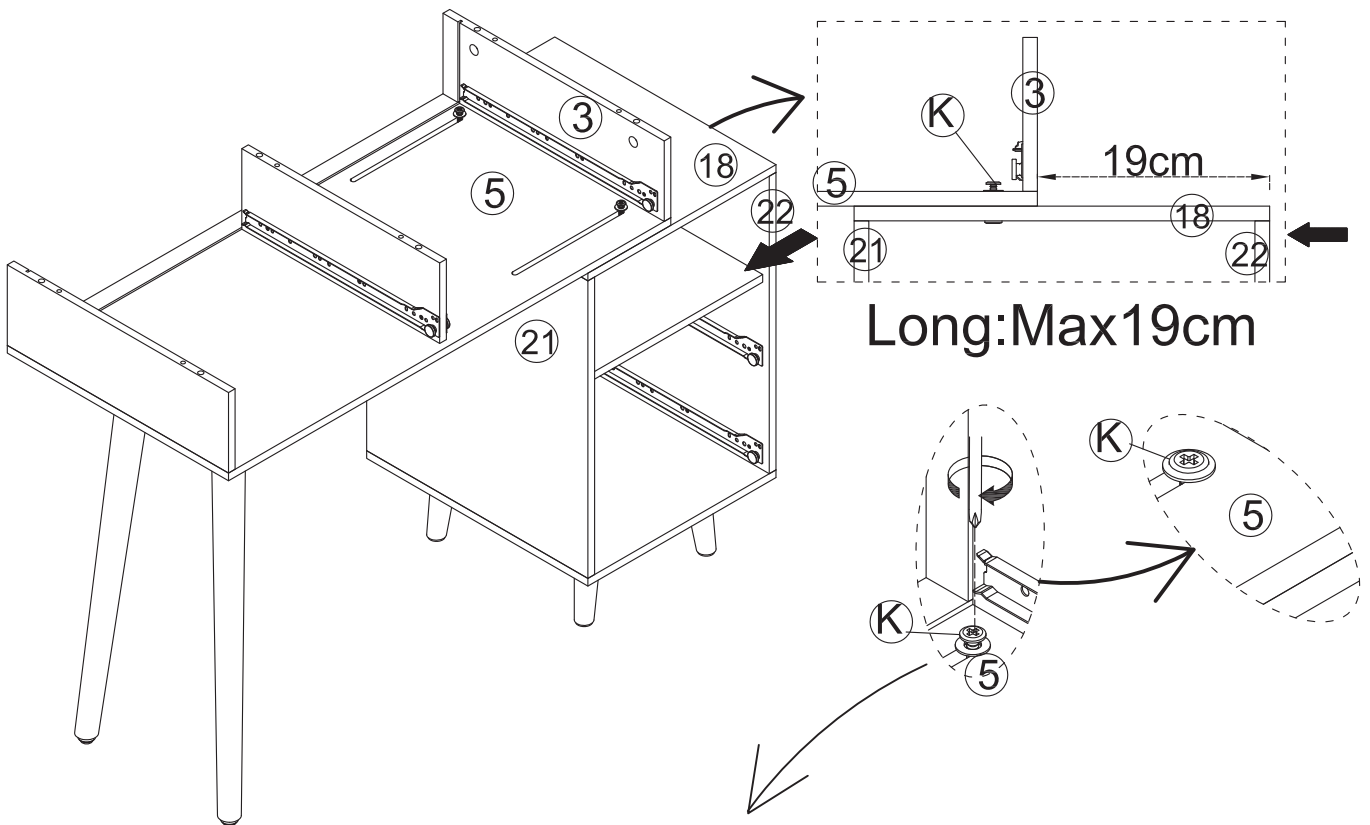

Long:Max 19cm

NOTE: Be sure to tighten (K) and (L) to maintain stability.

19

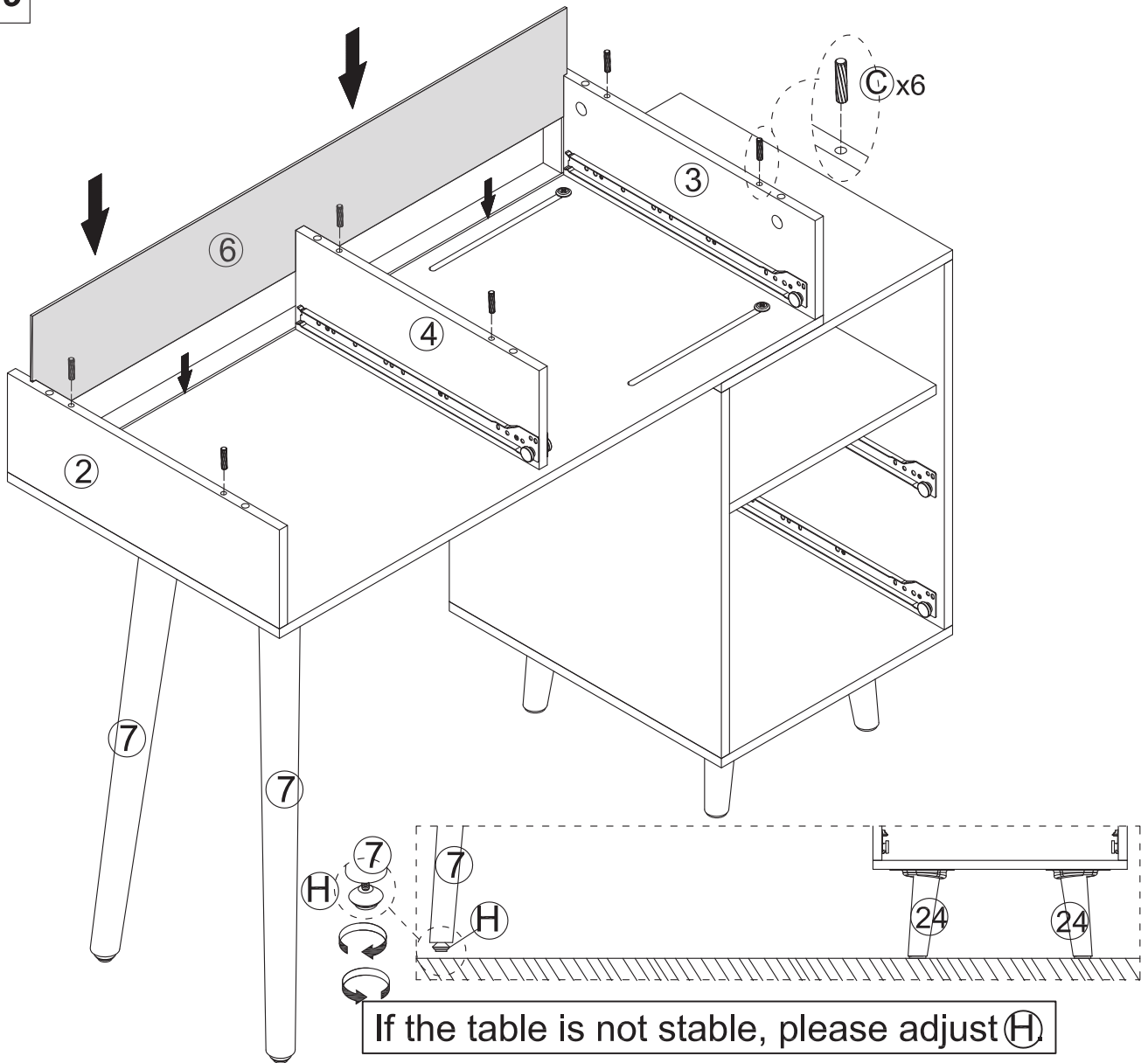



If the table is not stable, please adjust (H)

(C)	x6
	
Ø6x30mm	

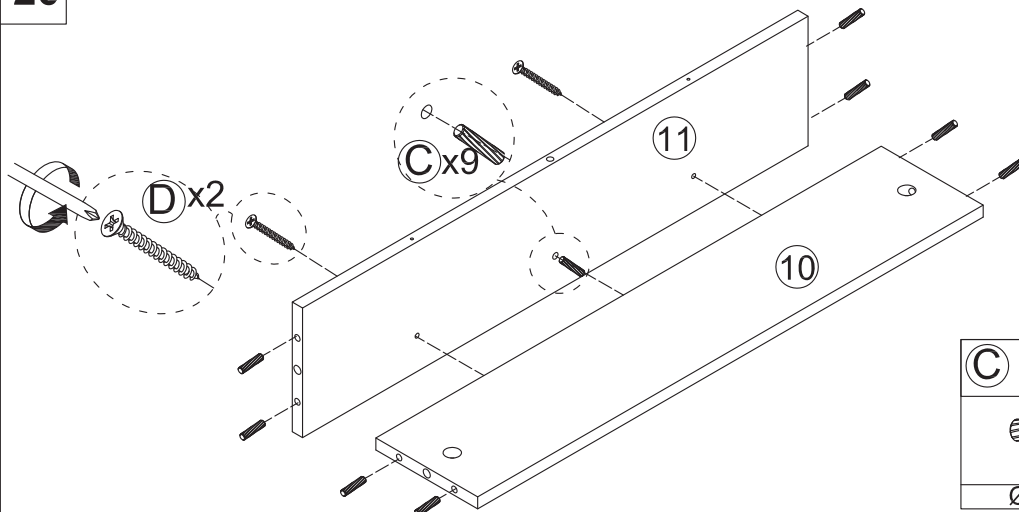
20



(C)	x9
	
Ø6x30mm	

(D)	x2
	

21

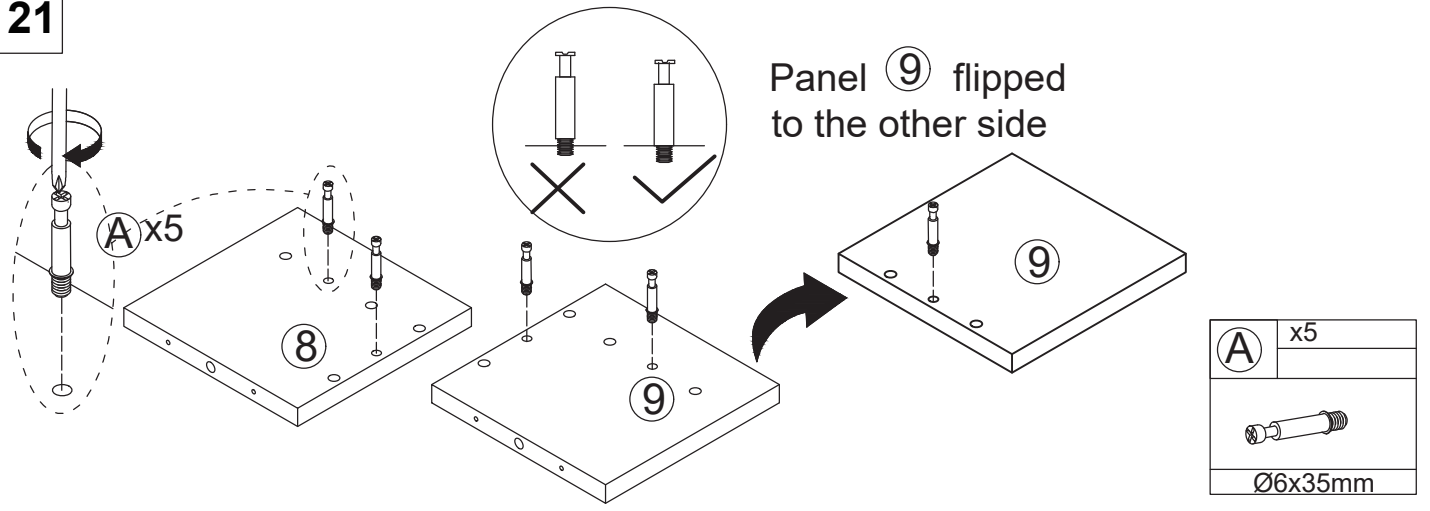

22

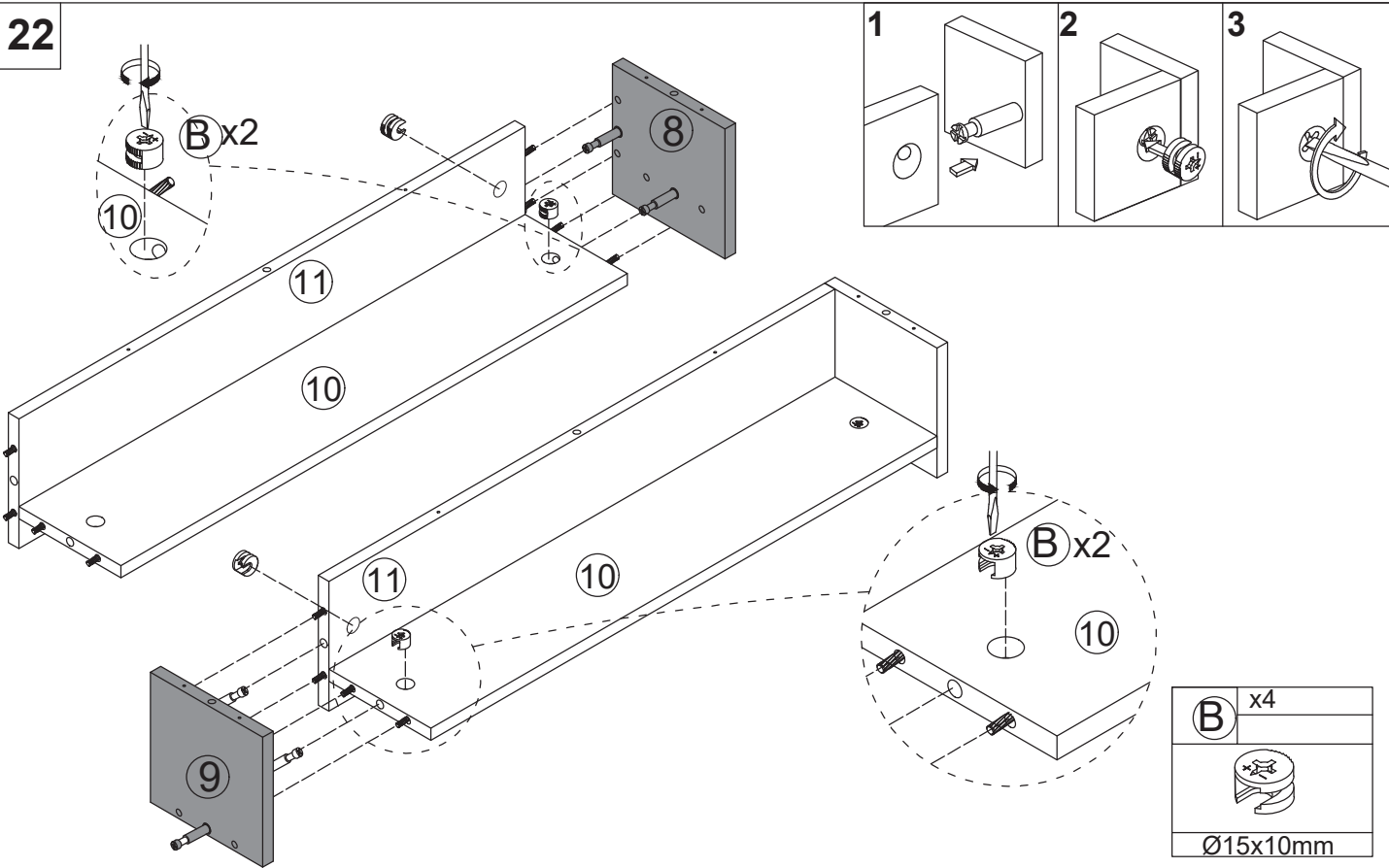

23

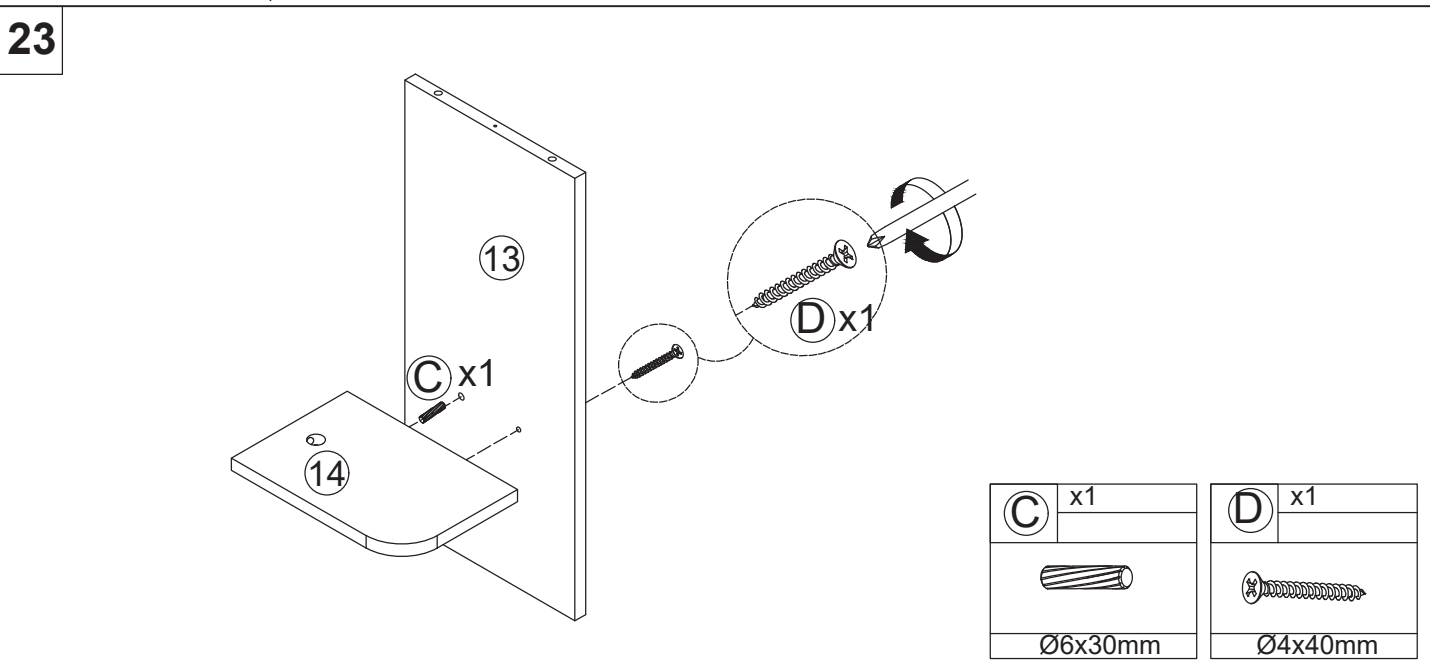

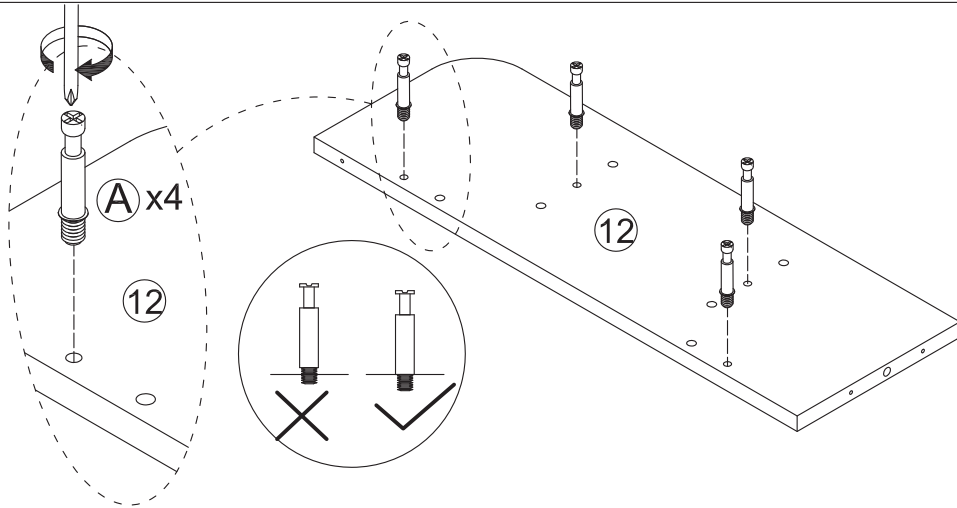

24



(A)	x4
	
Ø6x35mm	

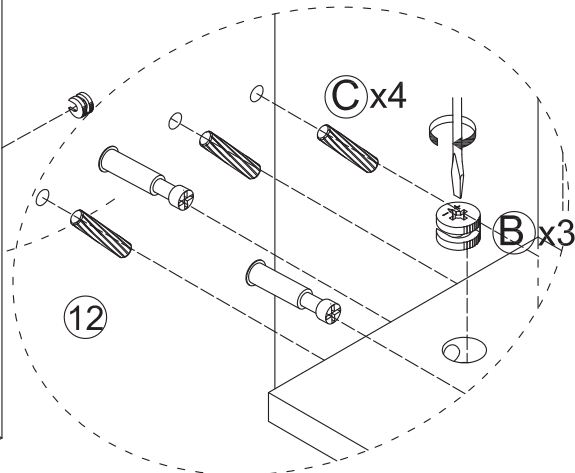
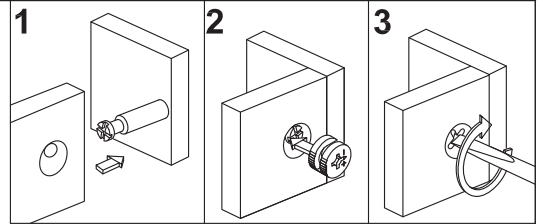
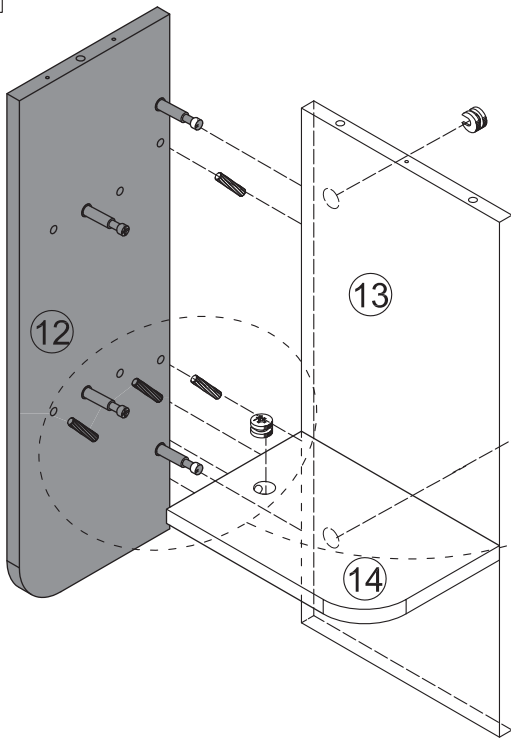

25

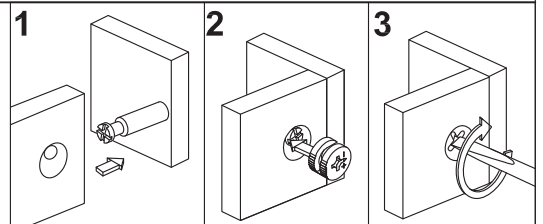
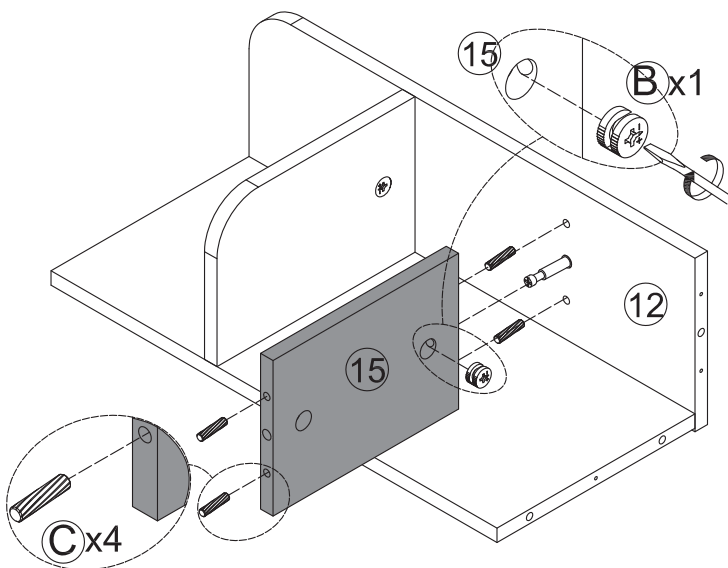

(B)	x3
	
Ø15x10mm	
(C)	x4
	
Ø6x30mm	

26



(B)	x1
	
Ø15x10mm	
(C)	x4
	
Ø6x30mm	

27

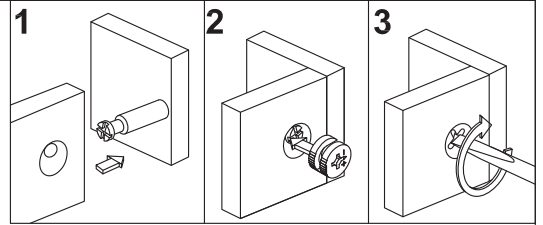
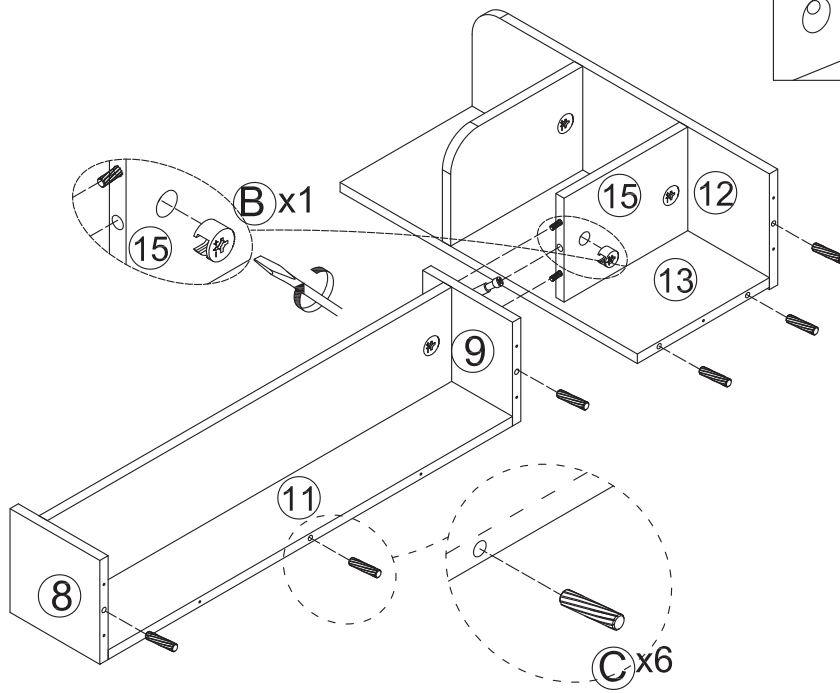

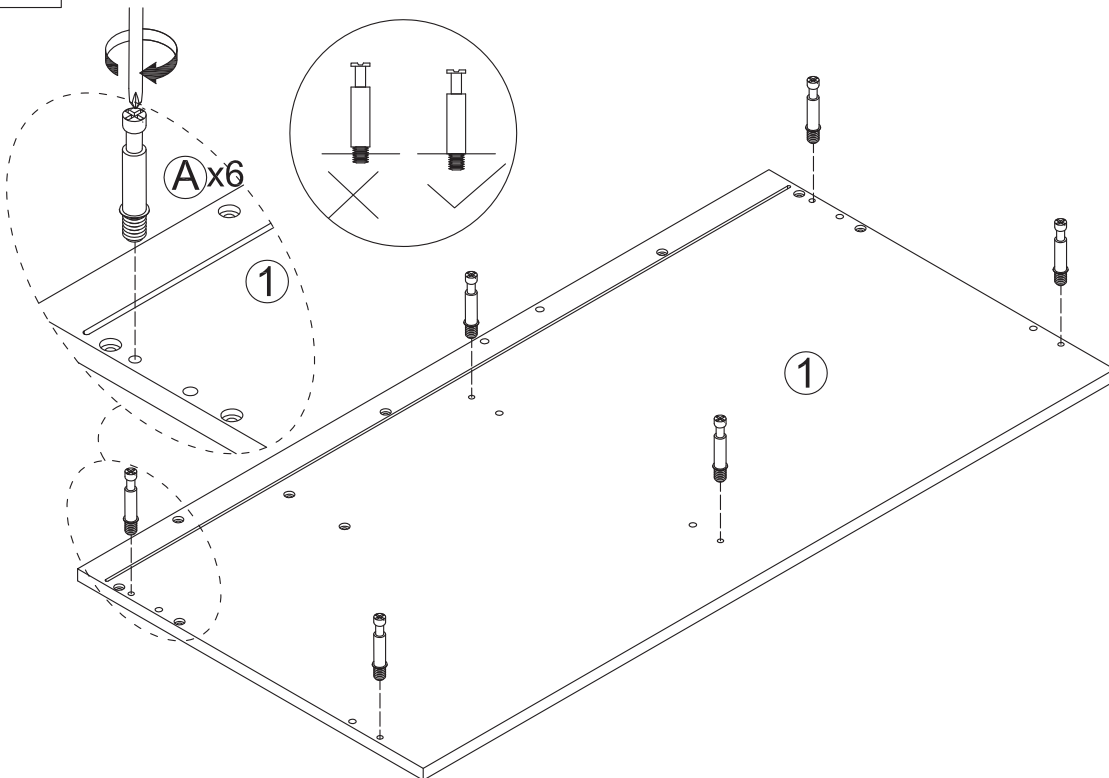

B	x1	C	x6
Ø15x10mm		Ø6x30mm	

28

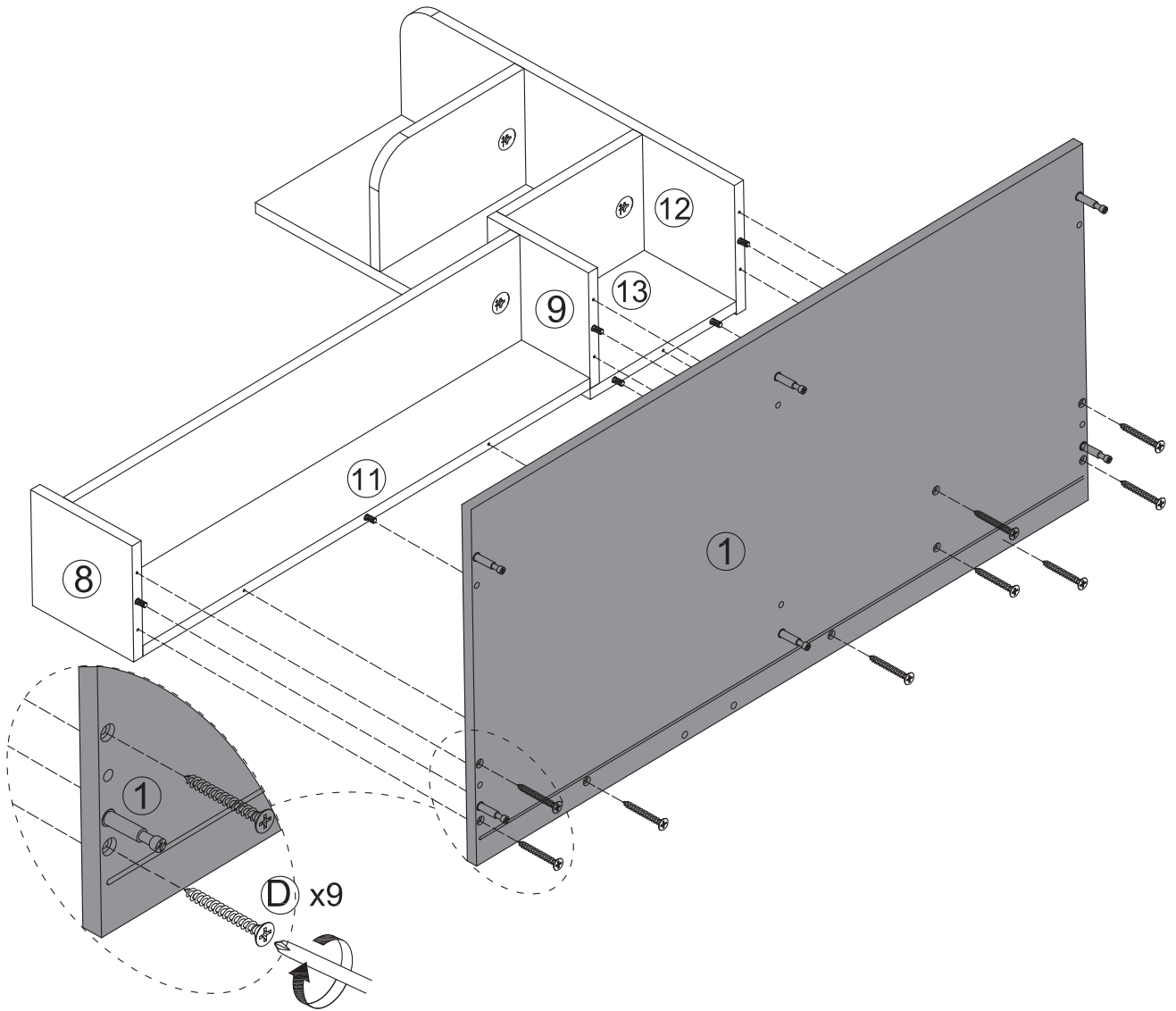

A	x6
Ø6x35mm	



(D)	x9
	
Ø4x40mm	

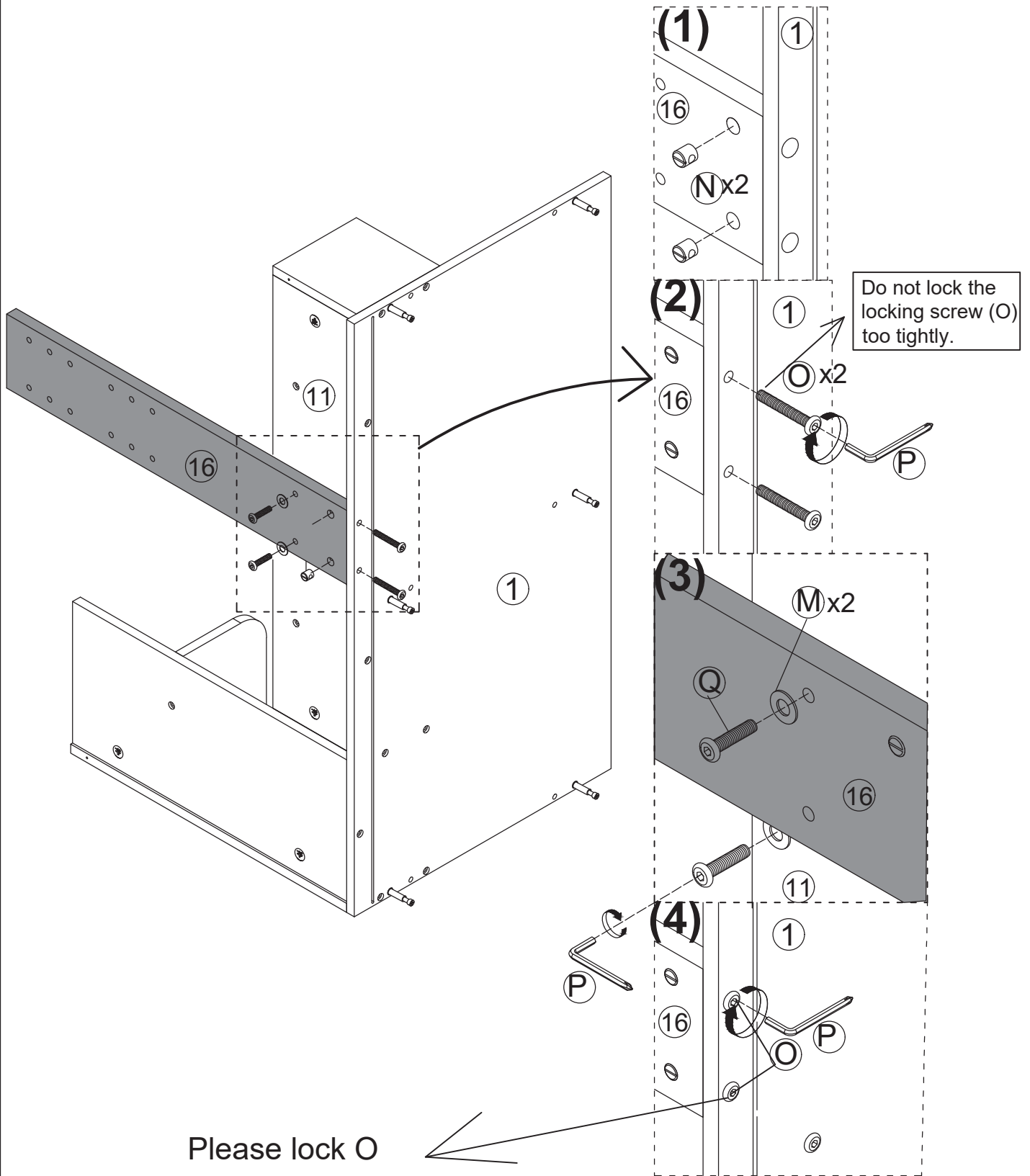

Please lock O

(M)	x2	(N)	x2	(O)	x2	(P)	x1	(Q)	x2
				Ø6x40mm		M4mm		Ø6x25mm	

31

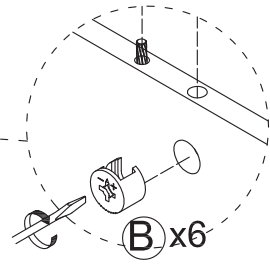
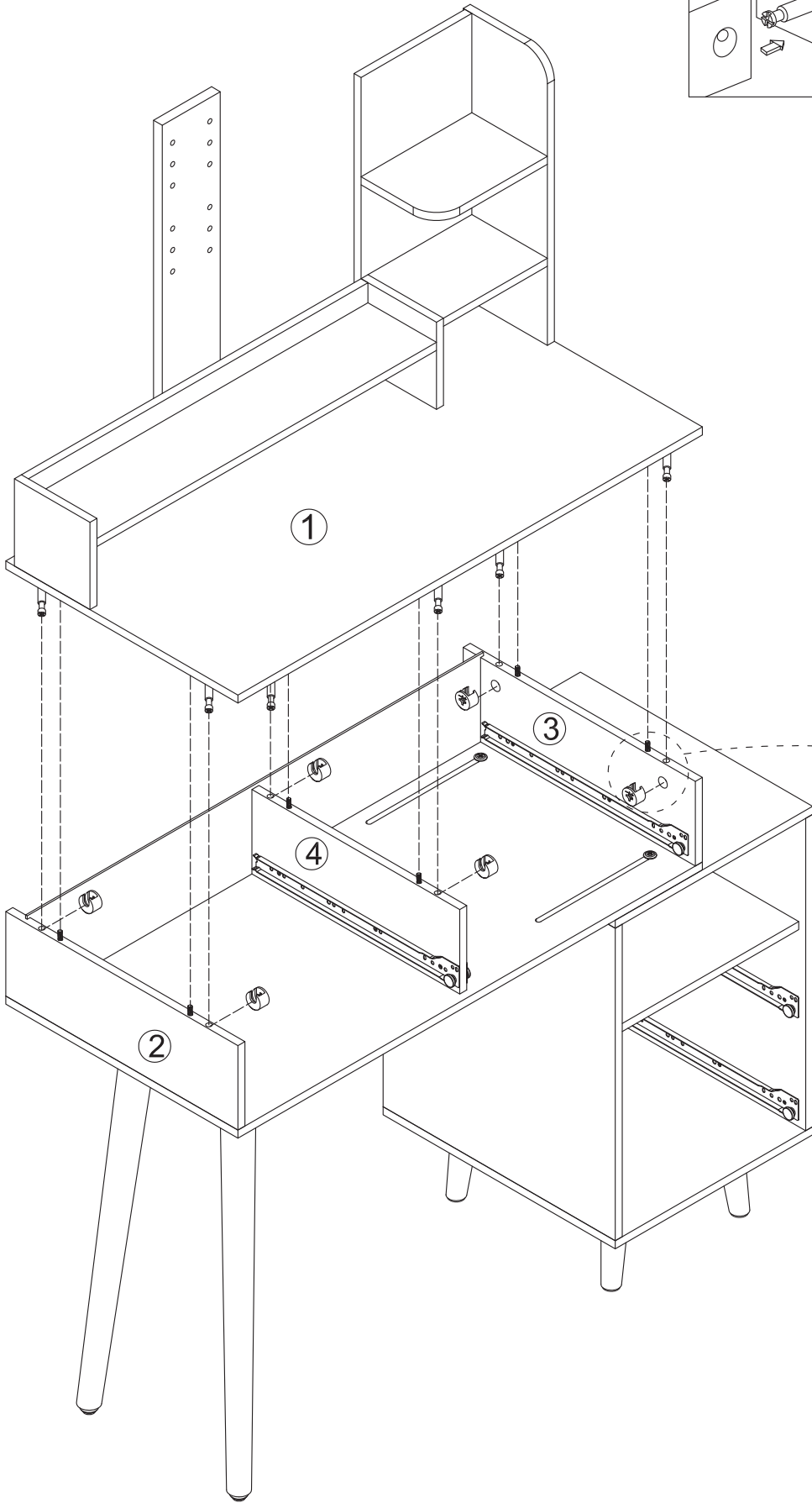
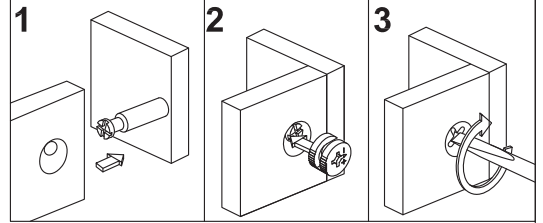

(B)	x6
Ø15x10mm	

32

According to the actual situation , choose one of the following three scenarios to install:

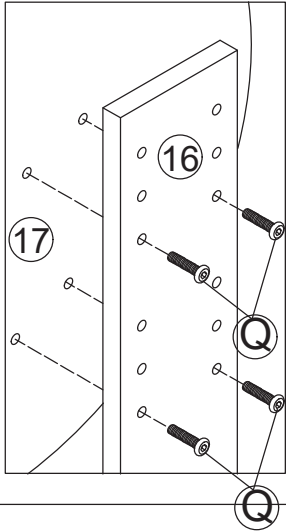

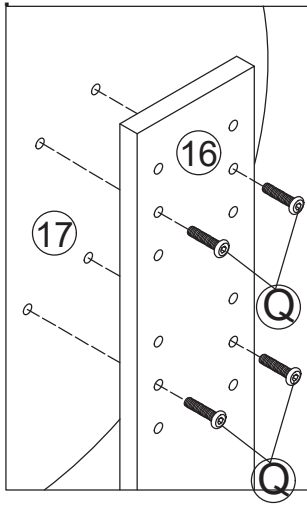

OR

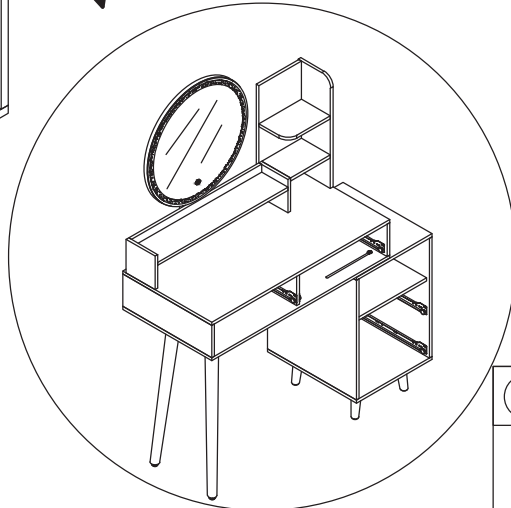
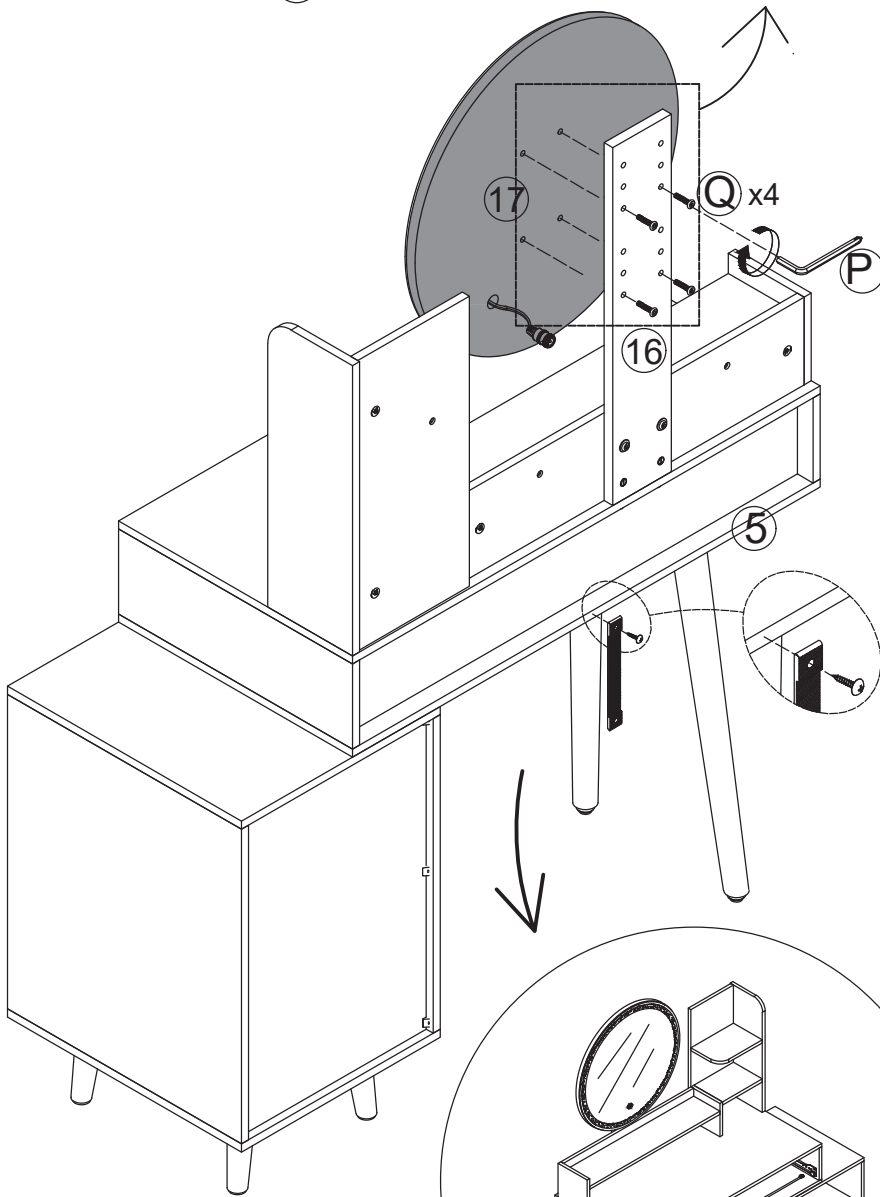
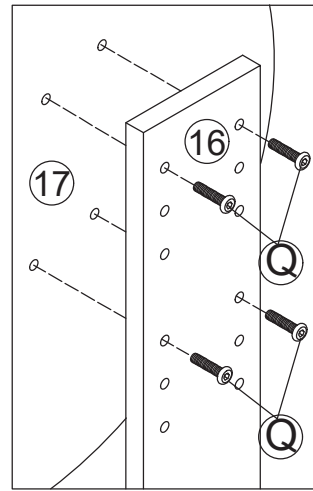

OR



T	x1
	
Q	x4
	
Ø6x25mm	
P	x1
	
M4mm	

33

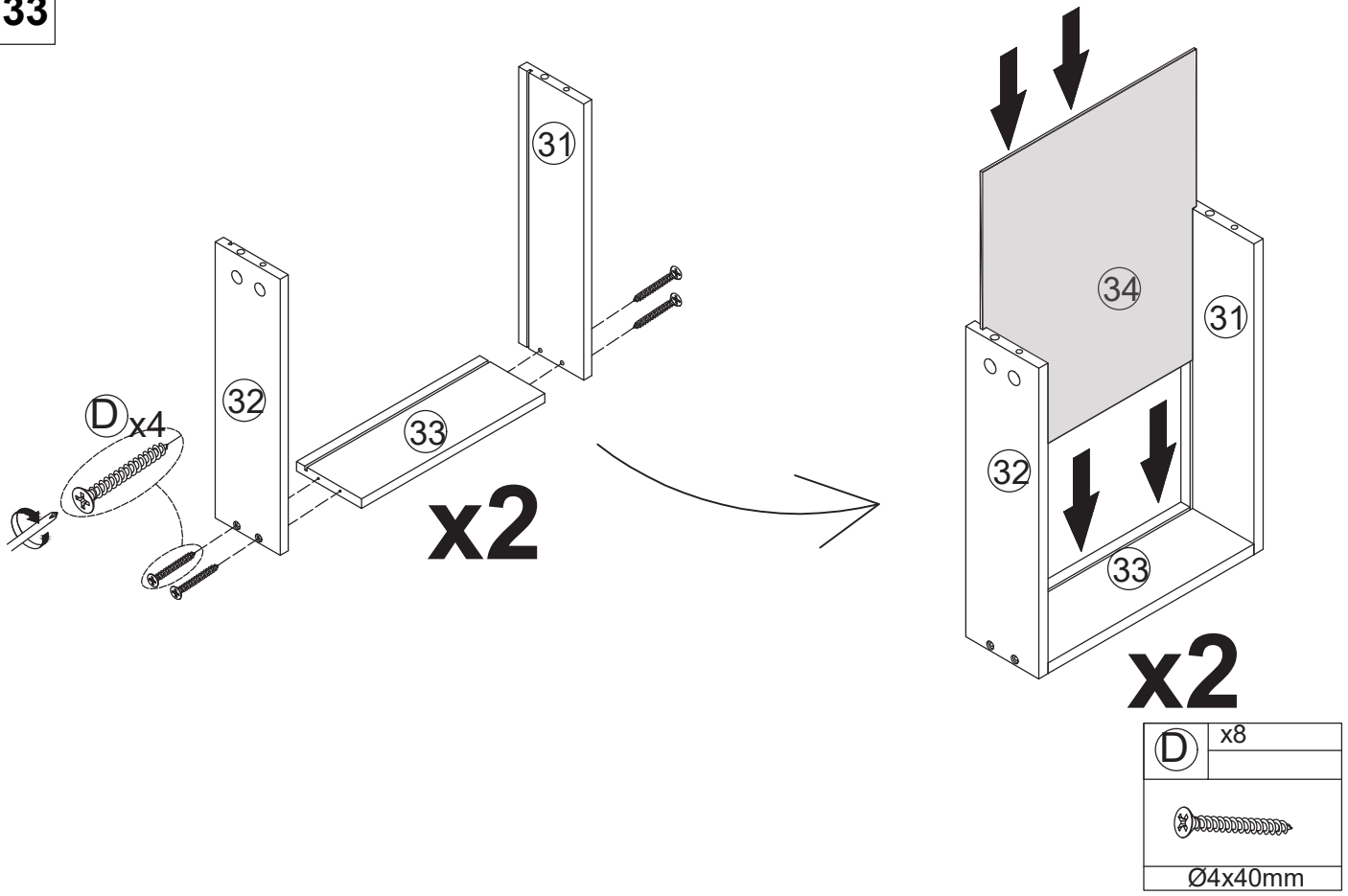

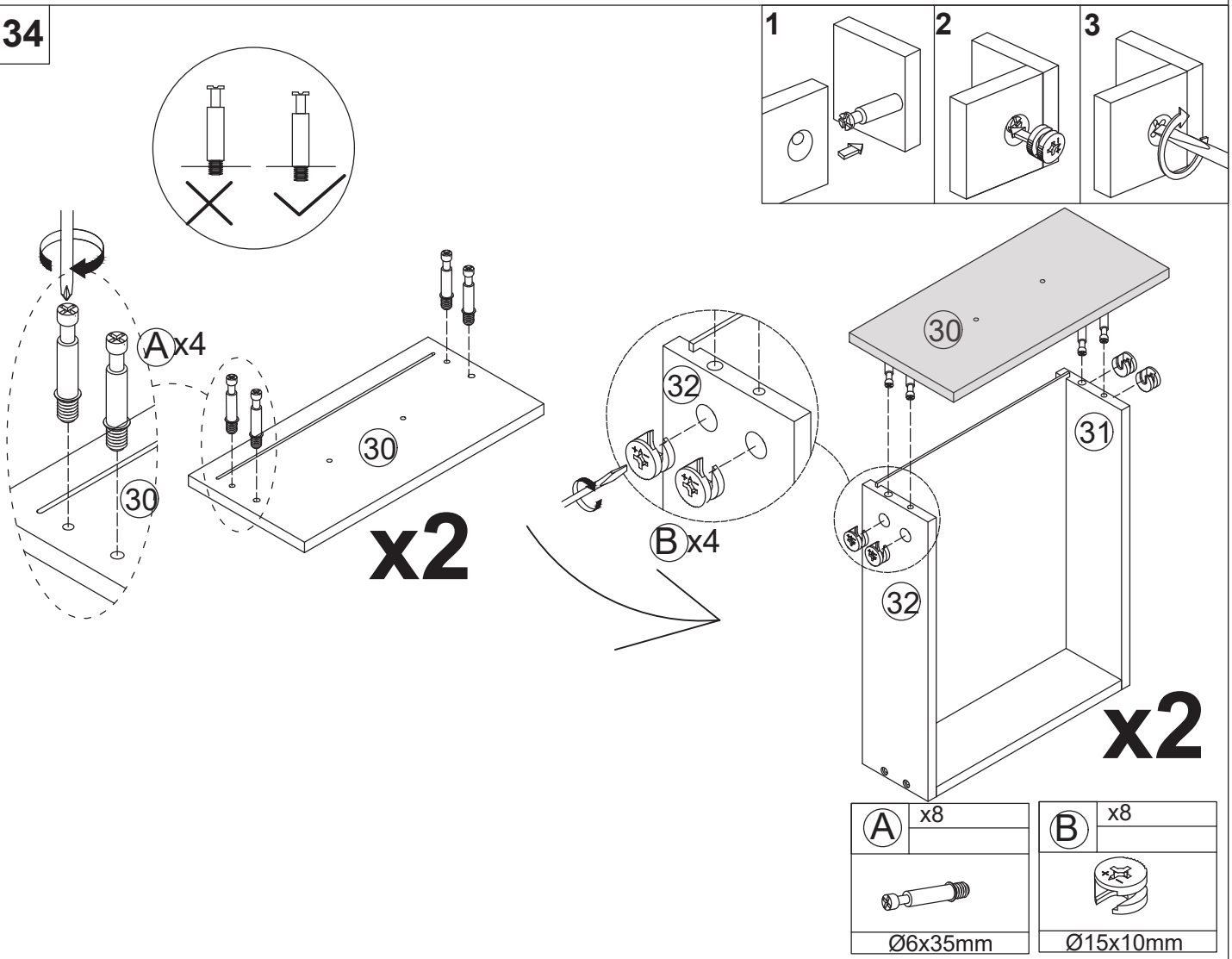

34



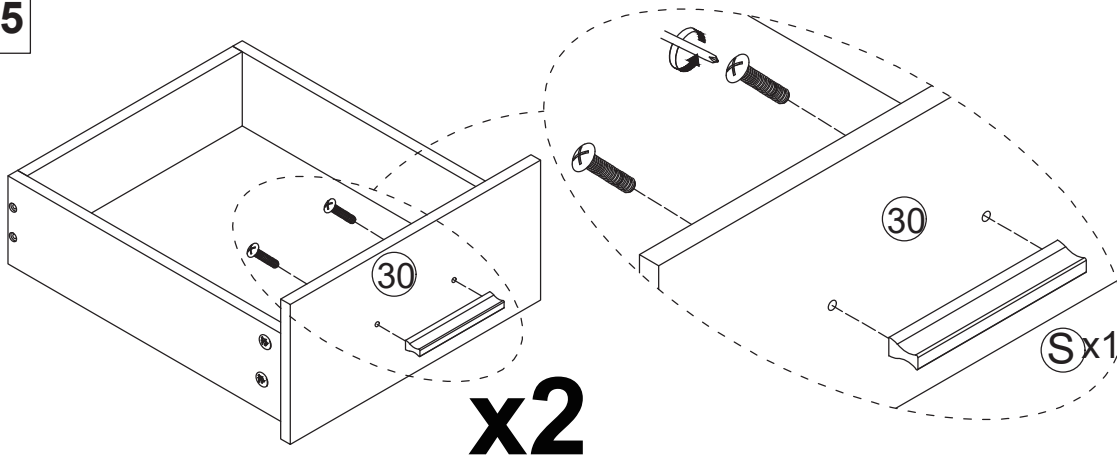



35

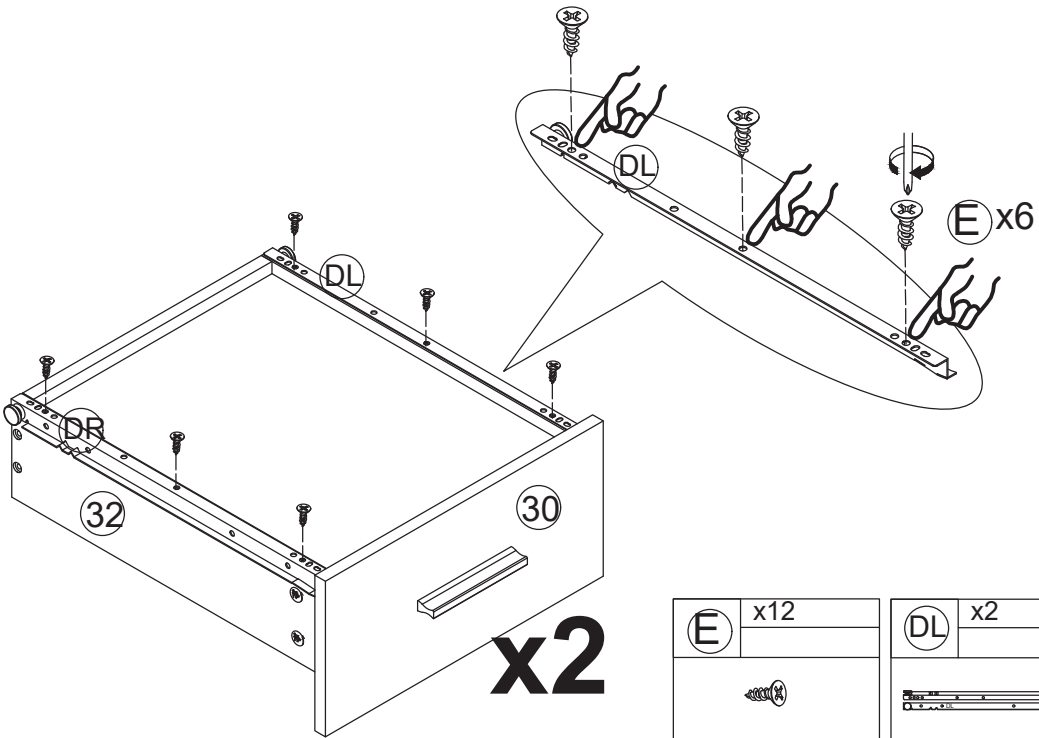

(S)	x2
	



36

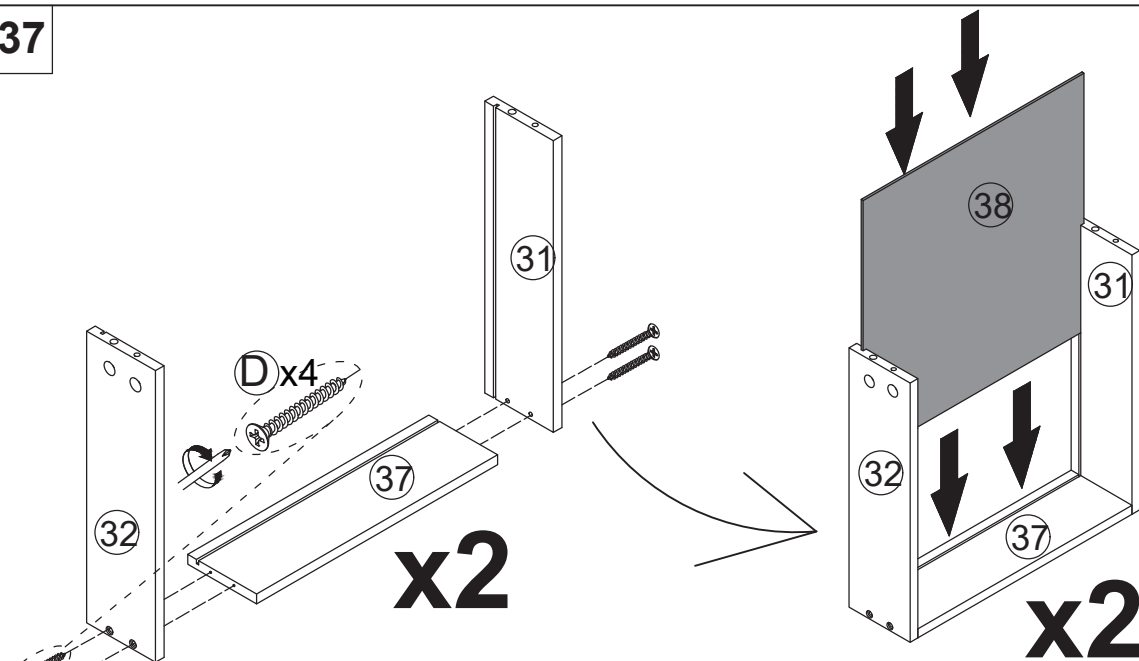

(E)	x12	(DL)	x2	(DR)	x2
			L350mm		L350mm

37



(D)	x8
	
Ø4x40mm	

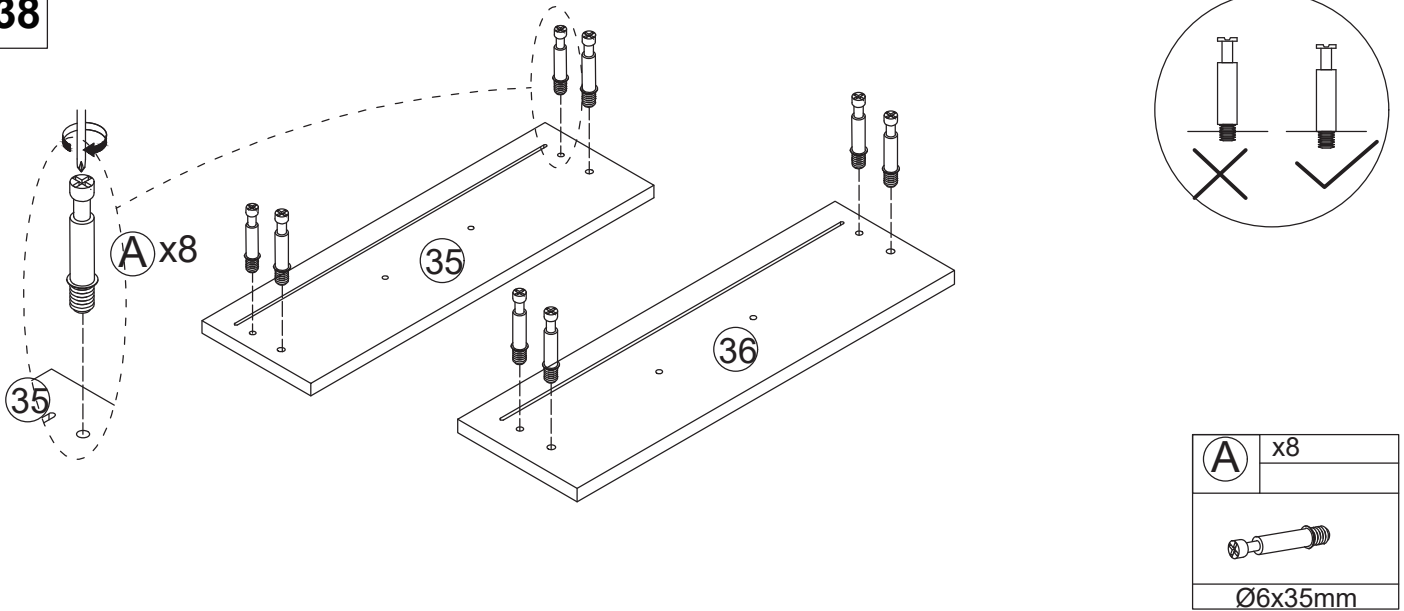

38

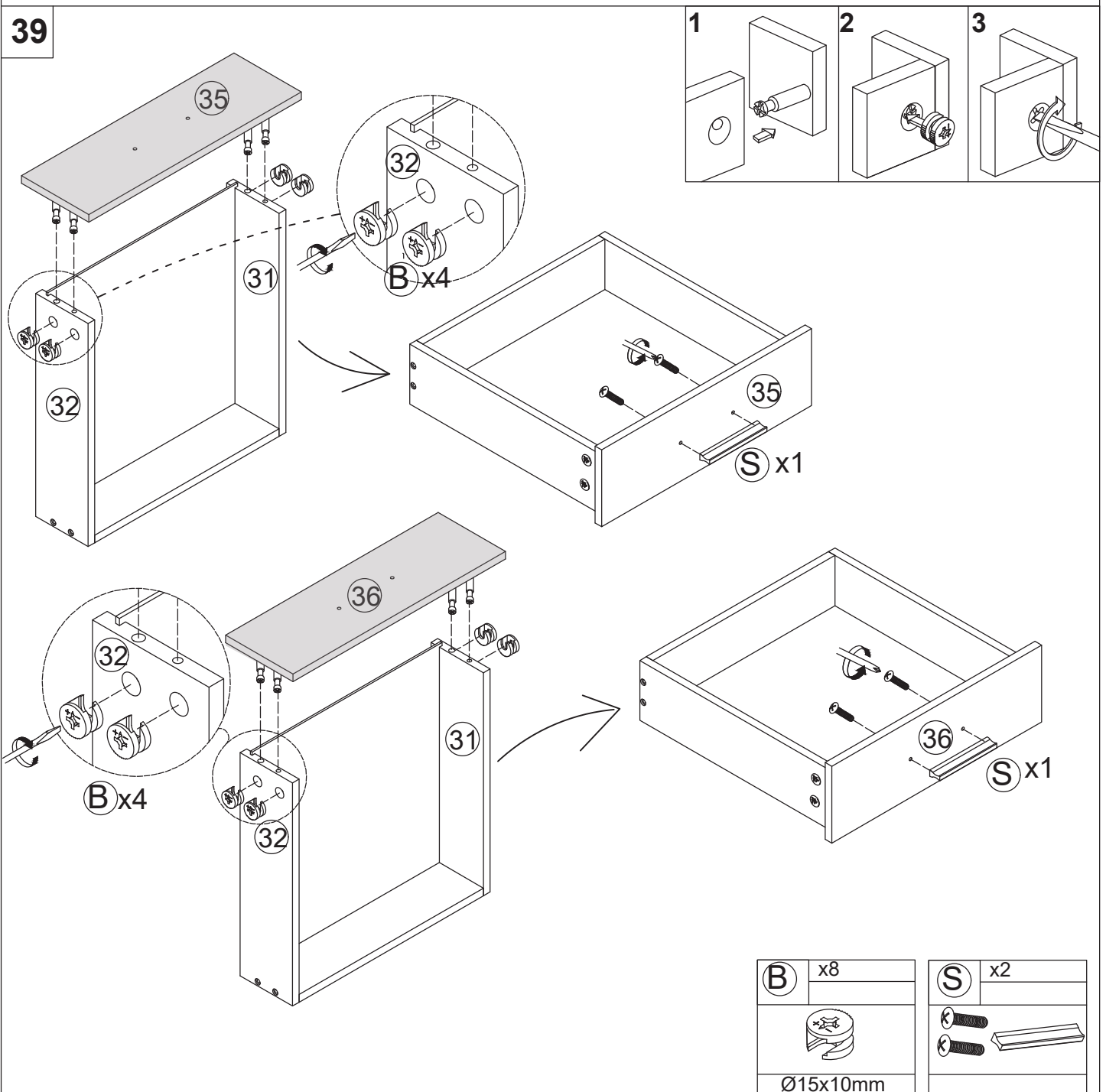

39

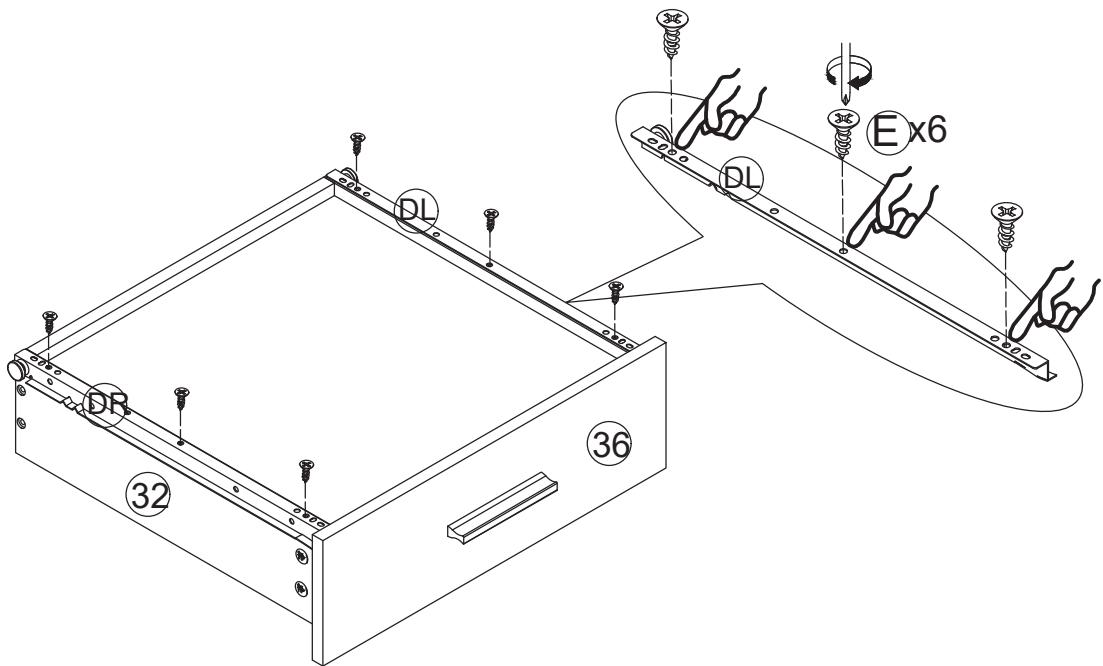
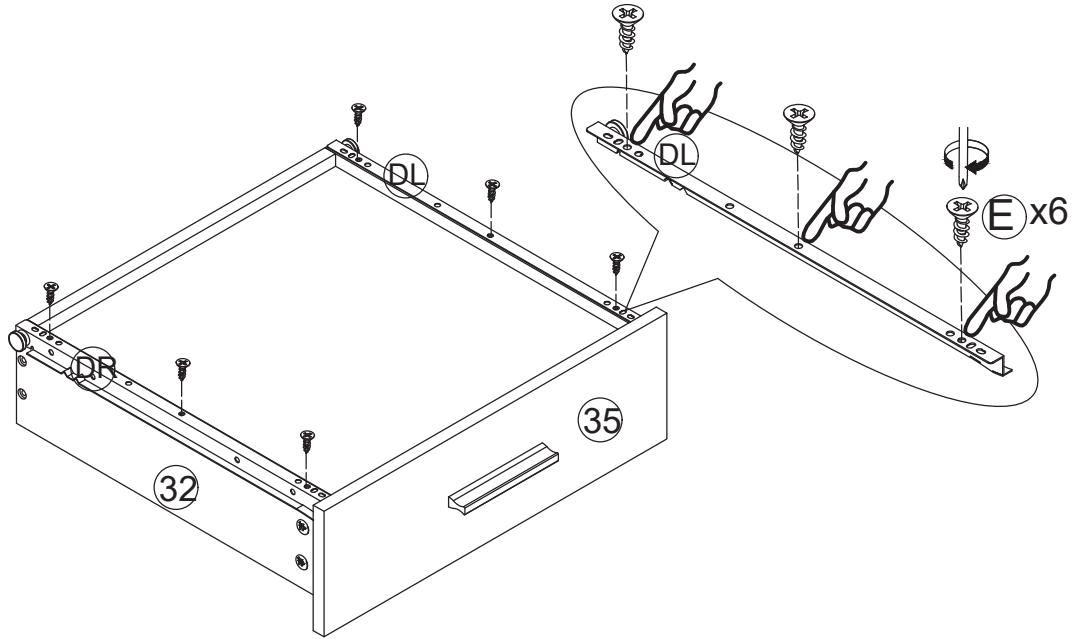



E	x12	DL	x2	DR	x2
					
		L350mm		L350mm	

(1)

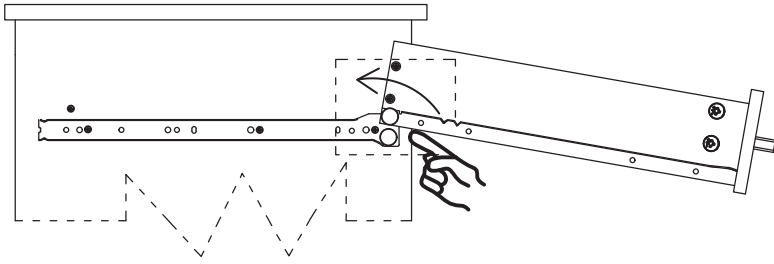

(2)

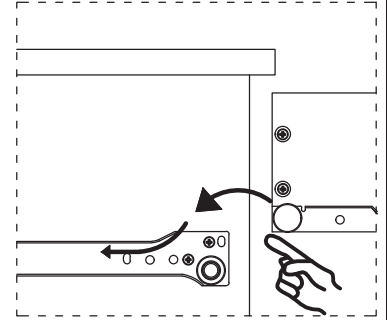
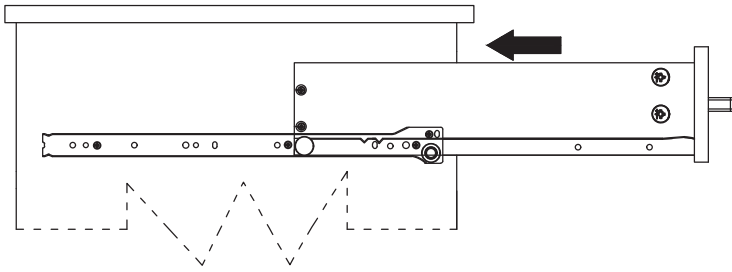

x4

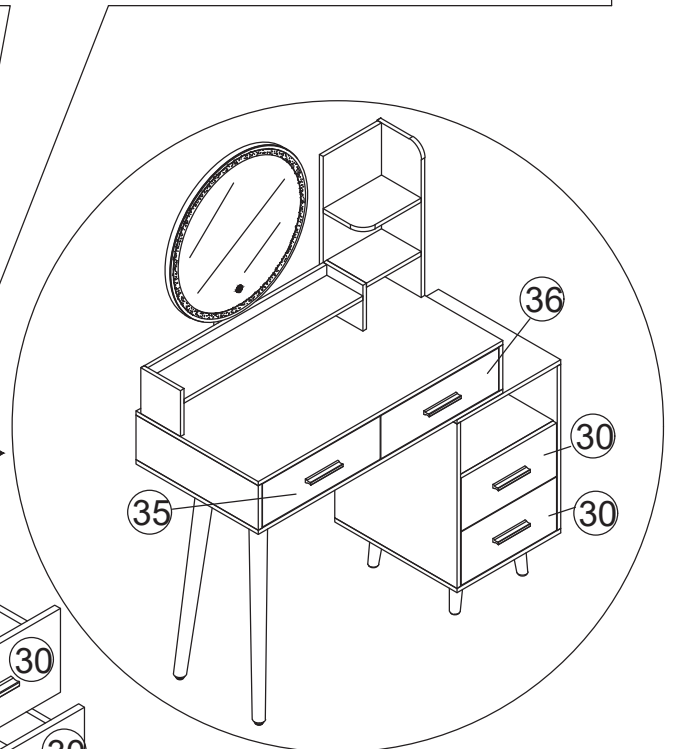
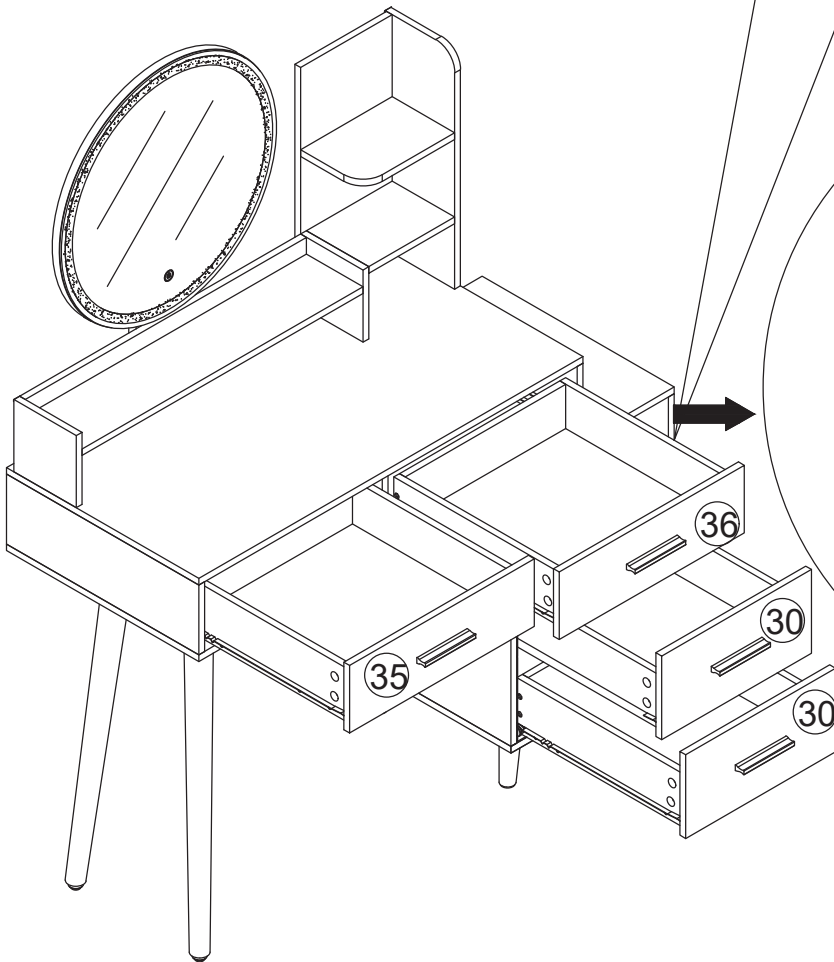

42

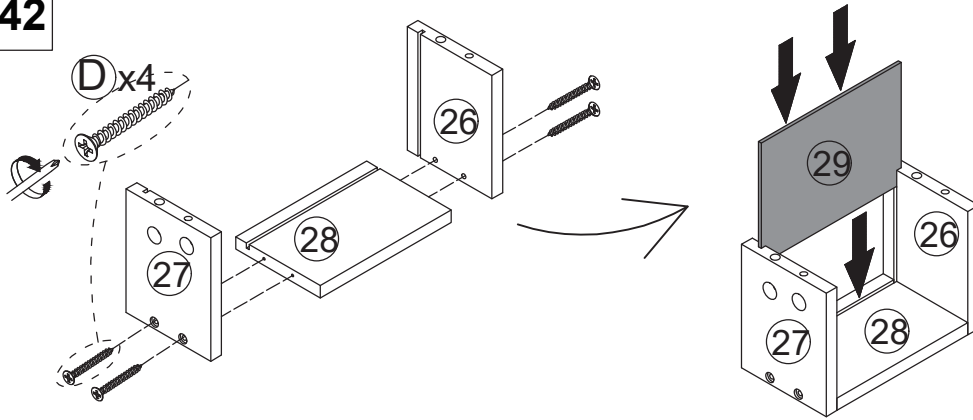

D	x4
Ø4x40mm	

43

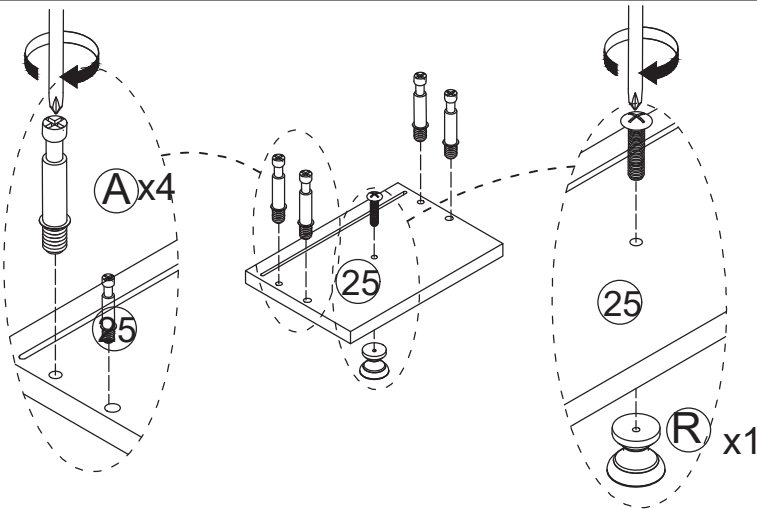

A	x4
Ø6x35mm	

R	x1

44

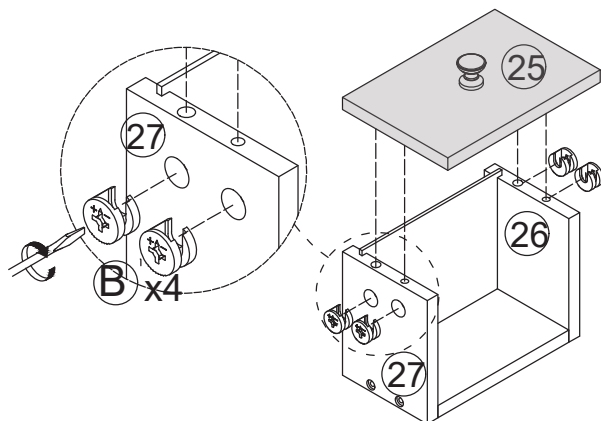
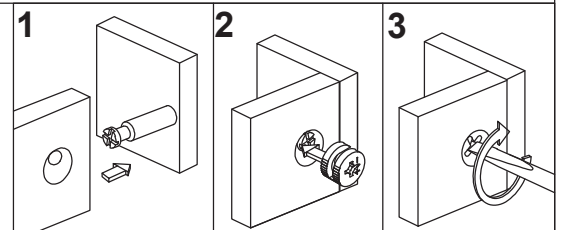

B	x4
Ø15x10mm	

(1)

Tape measure

(2)

Sharpie
Tape measure
Scissors

(3)

(4)

(5)

V	x1

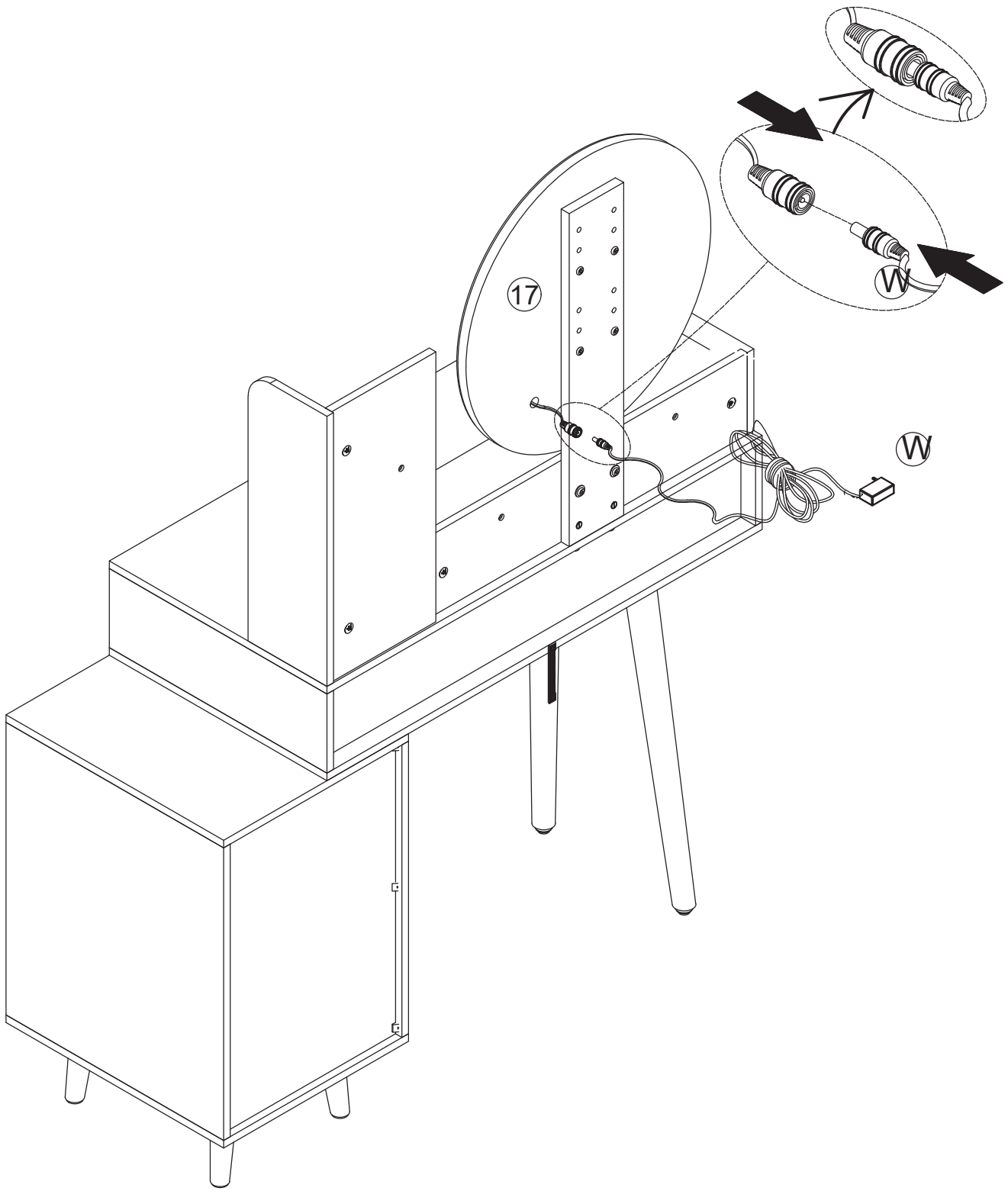

	x1
