

# Automatic Mahjong Table Instruction Manual

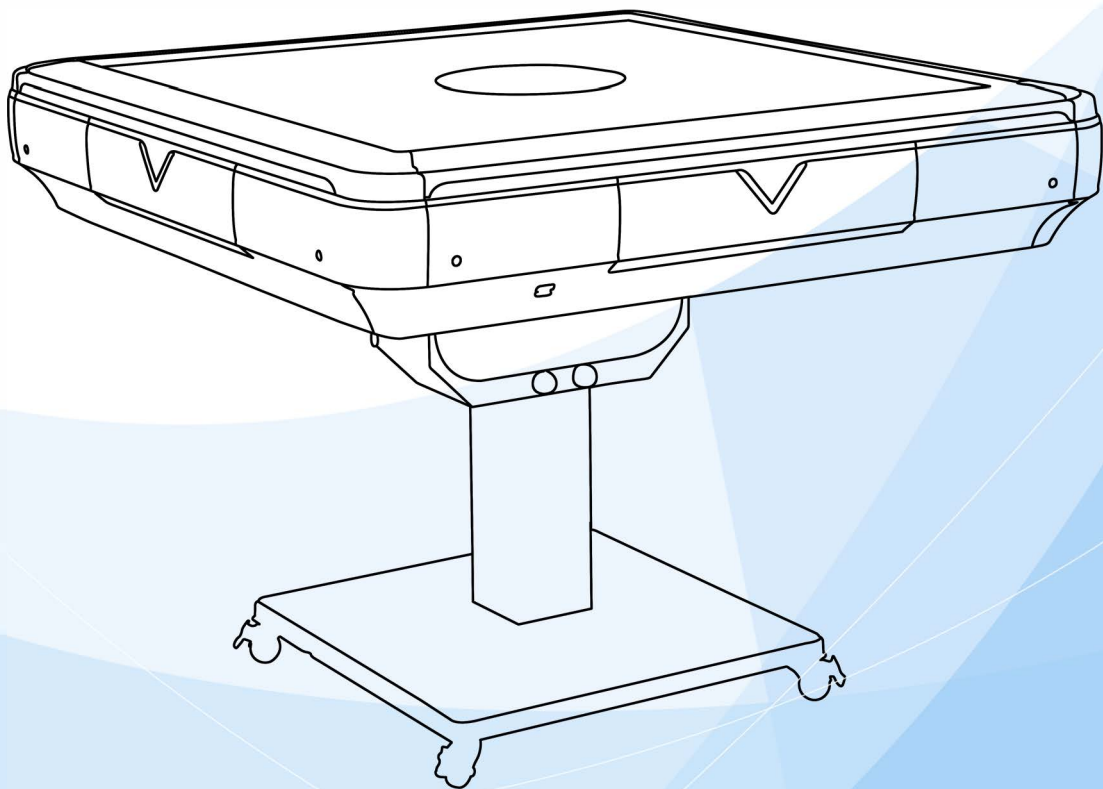

Installation Video Addresses



Please read the instruction carefully before use.

The rated power supply is 100V-120V/60Hz. Prohibited to use beyond the range!  
Use beyond the rated power range may cause equipment damage or safety accidents!

# Catalogs

## **01 Mahjong Machine Installation**

- 1.Received Product
- 2.Install folding legs
- 3.Install the movement
- 4.Mahjong machine trial operation
- 5.Install the border

## **02 Mahjong Machine Usage**

- 1.Notes on the use of mahjong machines
- 2.Operation panel function introduction
- 3.Mahjong Machine Operation Panel Instructions
- 4.Mahjong Machine Hide Tile Function
- 5.Mahjong machine folding function
- 6.Mahjong Machine Game Gear Setting
- 6.Maintenance and care of mahjong machine
- 7.Mahjong Machine Warranty Instructions

## **03 Mahjong machine problem checking and feedback**

- 1.Record of the malfunction for Mahjong table
- 2.Viewing Operator Panel Error Codes
- 3.Check if the signal wires and power supply are functioning properly.
- 4.Check if the tile lifting component is pushing the tiles properly.
- 5.Check if the tile lifting component is working properly.

# 1.Mahjong Machine Installation



## (1)Received Product



You will receive three packages, mahjong machine movement, mahjong machine bezel, and mahjong machine folding feet, (Mahjong tiles and folding feet packed in a common cardboard box)  
**(Reminder: Please be mindful of safety and floor protection when moving the main chassis)**

## (2)Install the bottom foot of Mahjong machine



①Firstly, open the folding leg box and take out the folding legs, mahjong tiles, and related accessories.

②The box contains a screwdriver and an L-shaped hex key, which will be the tools needed for later use.

③Open the accessory kit containing the required accessories and spare parts.

# Introduction to Accessories

## - Required Accessories and Spare Parts

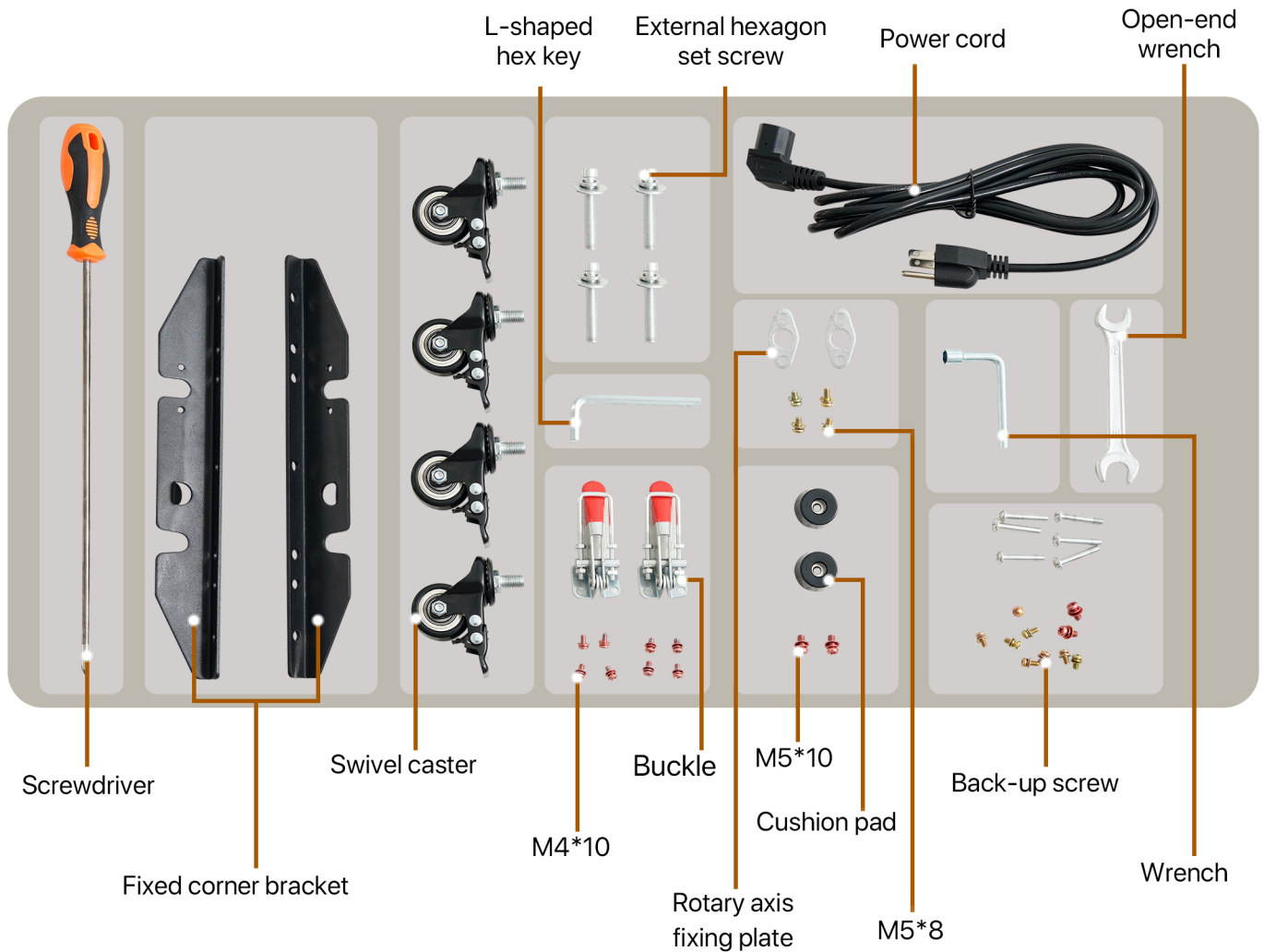

④ Place the column upside down on the floor and the chassis hole on the column.



⑤ Lock the brakes on the Cardan wheel and then lock the wheel clockwise.



⑥ Get M5 Bolt cross through the recoil pad, fix the two recoil pad with a screwdriver.



⑦ Fasten the two buckles to the folding foot with M4 bolts.

### (3) Install the movement



⑨ Stand the mainframe box upright and remove 8 metal connectors with a screwdriver.

(Caution: do not remove screws that is in contact with the ground, be careful of scratches)

⑩ Open the mainframe box from the bottom, take out the mainframe, the switch of the movement should be facing up.

(Reminder: the switch of the movement should be facing up)

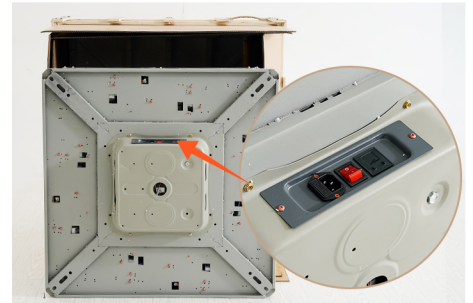

⑩ Remove four screws from both sides of the motor case and install the angle iron with four bolts.

(Caution: pay attention to the fixed direction of angle iron)



(Some of the products may have screws in the motor case that need to be removed first, they can be removed with socket wrench.)



⑪ Align the foot swivel with the corresponding notch, and lock the fixing plate in place.

⑫ After correctly installing the fastener and metal fixing plate, lock the fastener in place, and then turn the entire mahjong table over.

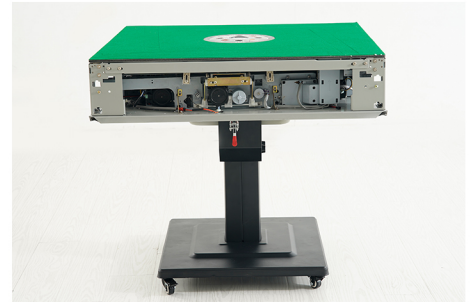

⑬ Remove all the pearl cotton protective block, cut off the tie.

⑭ Lock all four swivel casters for further easy installation and testing.



## (4)Mahjong machine trial run

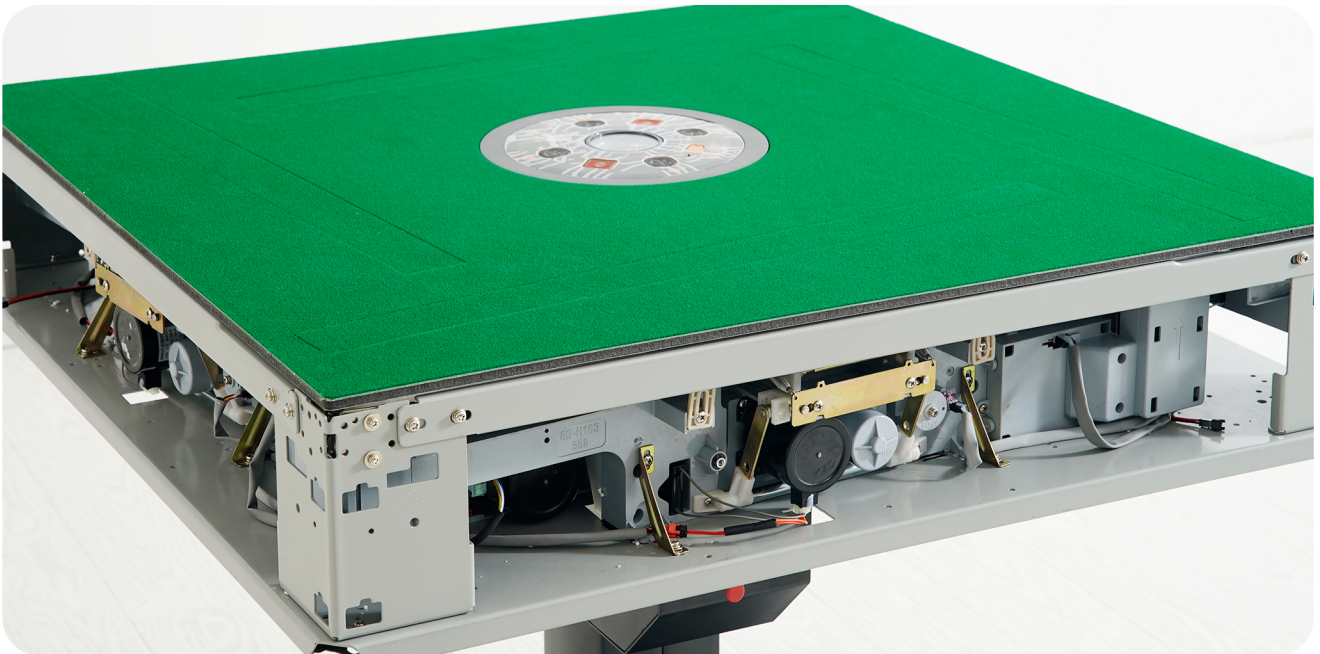

Connect it to power and turn on the power switch to check if the machine is working properly.  
(Note:If the machine is not working properly,please take a video and some photos and then contact us. We will help you to solve the problem.)

## (5)Install the side frame



①Open the package and take out the side frames and accessories.

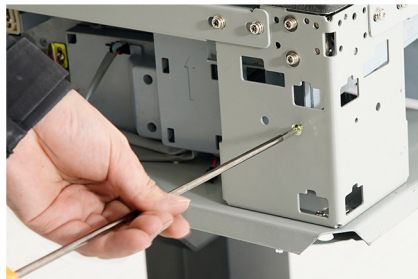

②Remove the 8 screws around the side of the movement in turn.  
(Caution: the swivel casters need to be locked)



③Connect the USB port and install the 4 side frames to the mainframe with the previous bolt.



④Fix the tapping screws on top of side frames



⑤The plastic fasteners are connected head to tail to form a square shape.The components are installed bytapping.Last, connect the power cord



⑥Tapping the parts to get them installed in place. Last,connect it to power and the installation is completed.

## 2.Operation of Mahjong Machine

### (1)Precautions for using Mahjong Machine

- 1.Do not put your hand inside the plate in case fingers get hurt.
- 2.Do not lift the table top while the mahjong machine is working to avoid unnecessary injuries.
- 3.Do not put your hand anywhere inside the machine while it is connected to power to avoid electric shock or injury to your body if the mechanism suddenly moves.
- 4.Do not allow children to play with hard mahjong tiles to avoid causing or accidental ingestion.
- 5.This mahjong machine is for healthy game entertainment only, do not use it for gambling. For the record, this is for entertainment purposes only and should not be used for gambling.

### (2)Operation panel function introduction

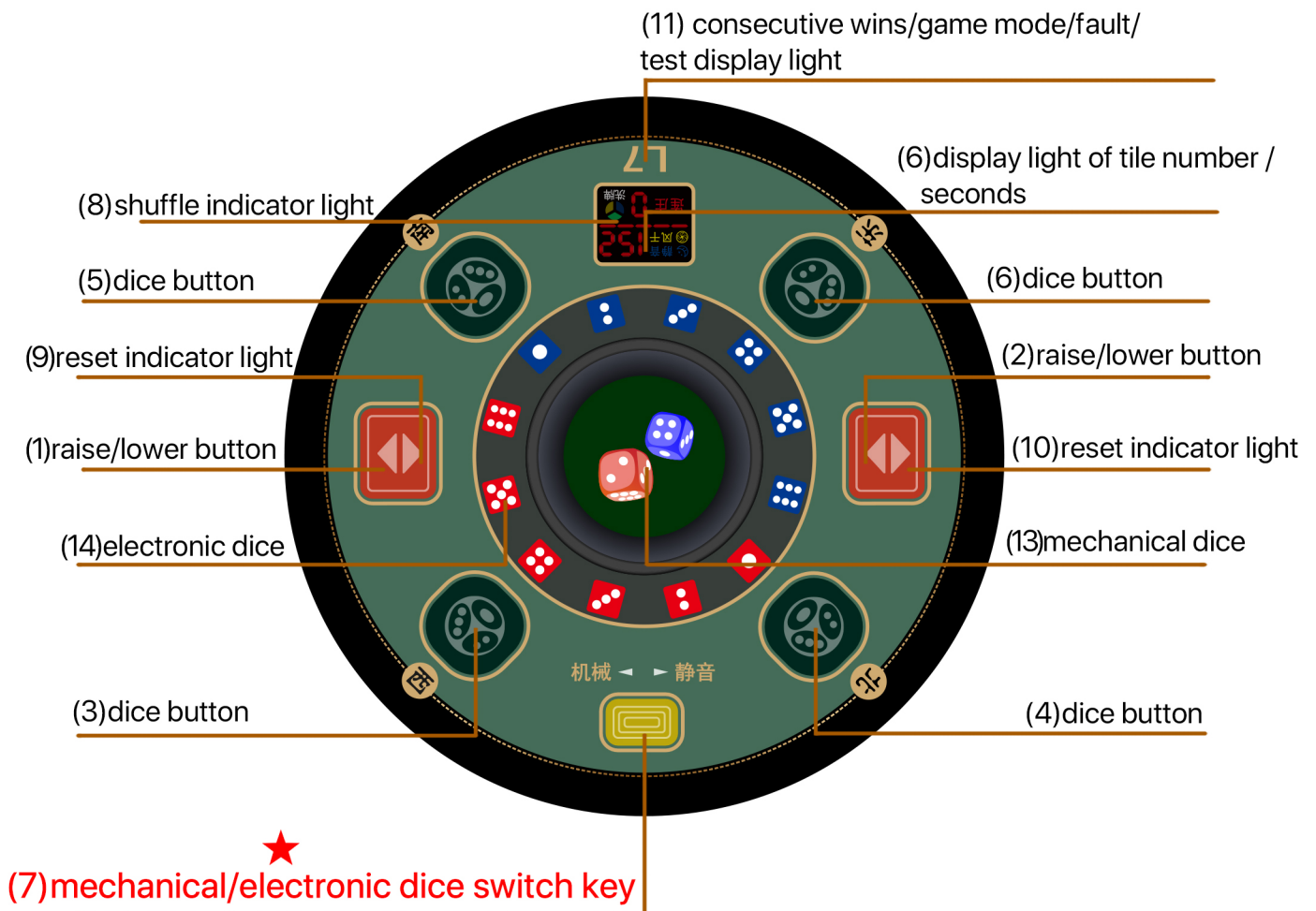

### (3)Operating Plate of Mahjong machine

- 1.Ensure the machine power switch is off, and plug the power cord into a properly grounded outlet.
- 2.This machine has power-off memory function. The license plate strip has been lowered to the low position before the new machine is transported, and there are no plates inside the machine.
- 3.Press both raise/lower keys at the same time, the central operating panel rises up, pour the first set of mahjong tiles into the shuffling area.
  - A. The number of mahjong tiles poured in must be consistent with the number indicated by the current gear, and it is prohibited to have too more or less tiles.

- B. Apart from the dedicated mahjong tiles provided, do not use other mahjong tiles and do not put any other items in the shuffling area.
4. Press any raise/lower key again, the operating panel descends, and the machine starts shuffling.
5. Wait until the reset indicator light turns red, indicating that the machine has finished shuffling. Press any raise/lower key at this time, the operating panel rises up, and put in the second mahjong tiles of the same quantity.
6. Press any raise/lower key again, the operating panel descends, and the first set of mahjong tiles poured in are lifted onto the table, while the second set of mahjong tiles are shuffled inside.
7. You can start the game now. Press the dice key, the dice will randomly jump, release the dice key, and the dice will naturally stop.
8. Repeat steps 5 to 7 in a loop to continue the game.

#### (4) Instructions for hidden tile function of mahjong machine (to be used in unfolding condition)



① When the mahjong tiles on the mahjong machine are completed raised and the internal mahjong shuffle is completed.



② Raise the control panel, push the mahjong tiles from the table into the machine.



③ Long press the two opposite dice buttons on the control panel to lower the control panel.

#### (5) Mahjong machine folding function



① Raise all two sets of tiles in the mahjong machine onto the table.



② Put the two sets of mahjong tiles into the box.



③ Fold and place the mahjong machine in a suitable place.

#### (6) Mahjong machine game mode settings



- A. Method 1: In the first few seconds before powering on, the game mode indicator light on the operating panel will display the game mode and flash.

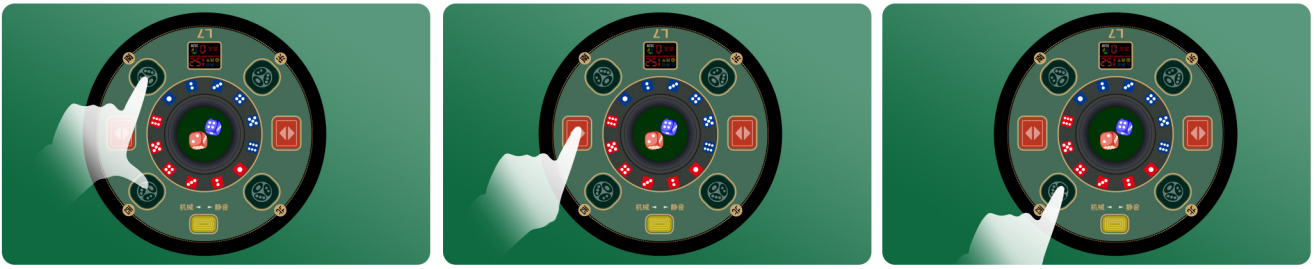

Method 2: First, let the current set of tiles finish shuffling, and after hearing the "beep" sound, proceed with the operation according to the procedure.

**Step 1:** Simultaneously press and hold any two adjacent dice keys for about 5 seconds. After hearing the "beep" sound, the machine turns to a mode adjustment mode. (At this time, the number shown on the display screen stands current game mode)

**Step 2:** Use the raise/lower keys to adjust to the desired game mode number. (For the game mode numbers, refer to the mode table: you can use both the left and right raise/lower keys)

**Step 3:** Press any dice key to confirm the game mode, and the mode adjustment is completed. (Press any one of the 4 dice keys to confirm)

Game Mode Digital Level Table

gear level	E	S	W	N	Total		E	S	W	N	Total
00					-		20	13	13	13	104
01	9	0	0	0	18		21	17	17	0	102
02	20	20	20	20	160		22	13	13	12	102
03	19	18	19	19	152		23	13	12	13	100
04	19	18	19	18	148		24	16	16	0	96
05	18	18	18	18	144		25	12	12	12	96
06	18	18	18	17	142		26	12	11	12	92
07	18	17	18	17	140		27	11	11	11	68
08	18	17	17	17	138		28	14	14	0	84
09	17	17	17	17	136		29	12	10	10	84
10	17	16	17	16	132		30	11	10	11	84
11	16	16	16	16	128		31	10	10	10	80
12	16	16	16	15	126		32	12	12	0	72
13	16	15	16	15	124		33	9	9	9	72
14	15	15	15	15	120		34	9	9	0	54
15	15	14	15	14	116		35	10	0	10	40
16	14	14	14	14	112		36	18	0	0	36
17	14	14	14	13	110		37	9	0	9	36
18	18	18	18	0	108		38	16	0	0	32
19	14	13	14	13	108		39	17	17	17.5	137

## (7) Mahjong machine maintenance and care

To extend the machine's lifespan, please regularly perform maintenance work.

1. Do not place the mahjong machine under direct sunlight or in areas prone to wind, frost, rain, or excessive dust to avoid affecting its performance and reducing its lifespan.
2. When placing the machine, ensure that the tabletop is parallel to the ground and not excessively tilted.
3. Keep the tabletop clean and avoid scratching the surface fabric.
5. Prevent liquids from entering the mahjong machine to avoid damaging the machine.
6. Avoid strong collisions and do not hit the machine forcefully to prevent damage.
7. Regularly clean the mahjong tiles to keep them dry, smooth, and clean.
8. Do not put debris into the large plate to prevent it from falling under the large plate and damaging the rotating structure.
9. Have professional maintenance personnel check the internal circuits regularly and wipe off the dust accumulated on the surface of the counting sensor. (Do not handle it yourself to avoid injury)

## (8)Mahjong machine warranty instructions

Our company solemnly promises: With the warranty card and invoice, you can receive high-quality after-sales service.

- 1.The whole machine is covered by a free one-year warranty from the date of purchase.
- 2.The following situations are not covered by the warranty service:
  - A. Damages caused by improper transportation, handling, use, or storage by the user.
  - B. Damages caused by the user's disassembly or repair without authorization from the company.
  - C. Altered invoices or lack of purchase invoice and warranty card.
  - D. Damages caused by abnormal voltage, water, fire, or other external factors.
  - E. Damages caused by irresistible factors or damage caused by human factors.
  - F. Consumables are not covered by the warranty, such as: mahjong tiles, outer frame, tabletop fabric, dice glass, etc.
- 3.Even if it is beyond the warranty period or not covered under the free warranty, our company will still wholeheartedly provide services for you.

★The warranty period starts from the date of sale, so please properly keep the warranty card and purchase invoice.

★Our company reserves the final right to interpret this warranty statement and scope.

Precautions for safe use

- For safety reason during use, please read the "product manual" carefully before use.
- The products listed in the product manual may undergo some changes without prior notice, please understand.
- The colors of the products listed in the product manual may differ slightly from the actual product due to printing.
- The products advertised and listed in the product manual may experience stock shortages.

## 3. Mahjong machine troubleshooting and feedback



Fault Item	
1	Missing tiles or large plate motor failure
2	Center lifting motor or sensor failure
3	Head motor or sensor failure
4	Lifting motor or sensor failure
5	Motor short circuit fault
6	Low voltage fault

①Take photos/videos of the malfunction so we can verify the issue promptly.

②Take photos/record videos of the error code displayed on the control panel.

③Explanation of the error codes corresponding to the control panel.

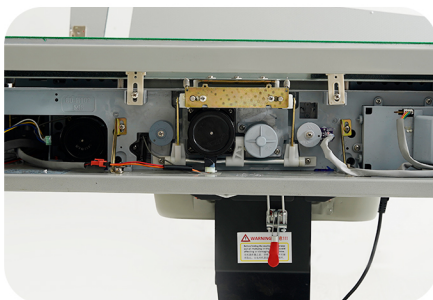

④Take photos/record videos to check if the signal wires and power cords are loose at two points, and check if there is any sound from the motor.

⑤Take photos/record videos to check if the tile lifting component is working properly.

⑥Take photos/record videos to check if the tile lifting component is moving up and down properly.



The Company reserves the right of final interpretation of the warranty description and coverage.

## Precautions for Safe Use

- For safe use, please read "Read the user's product manual and instructions carefully before use".
- The number of products included in advertisements and brochures is subject to change without notice.
- Due to printing, the color of the product in advertisements and manuals may differ from the actual product.
- Products listed in advertisements and brochures may be out of stock.
- Please check the manufacturing number at the time of purchase.

**PS: When purchasing, please fill out the Product Warranty Form and keep it in a safe place.**