

CHEVRON BED

ASSEMBLY INSTRUCTIONS

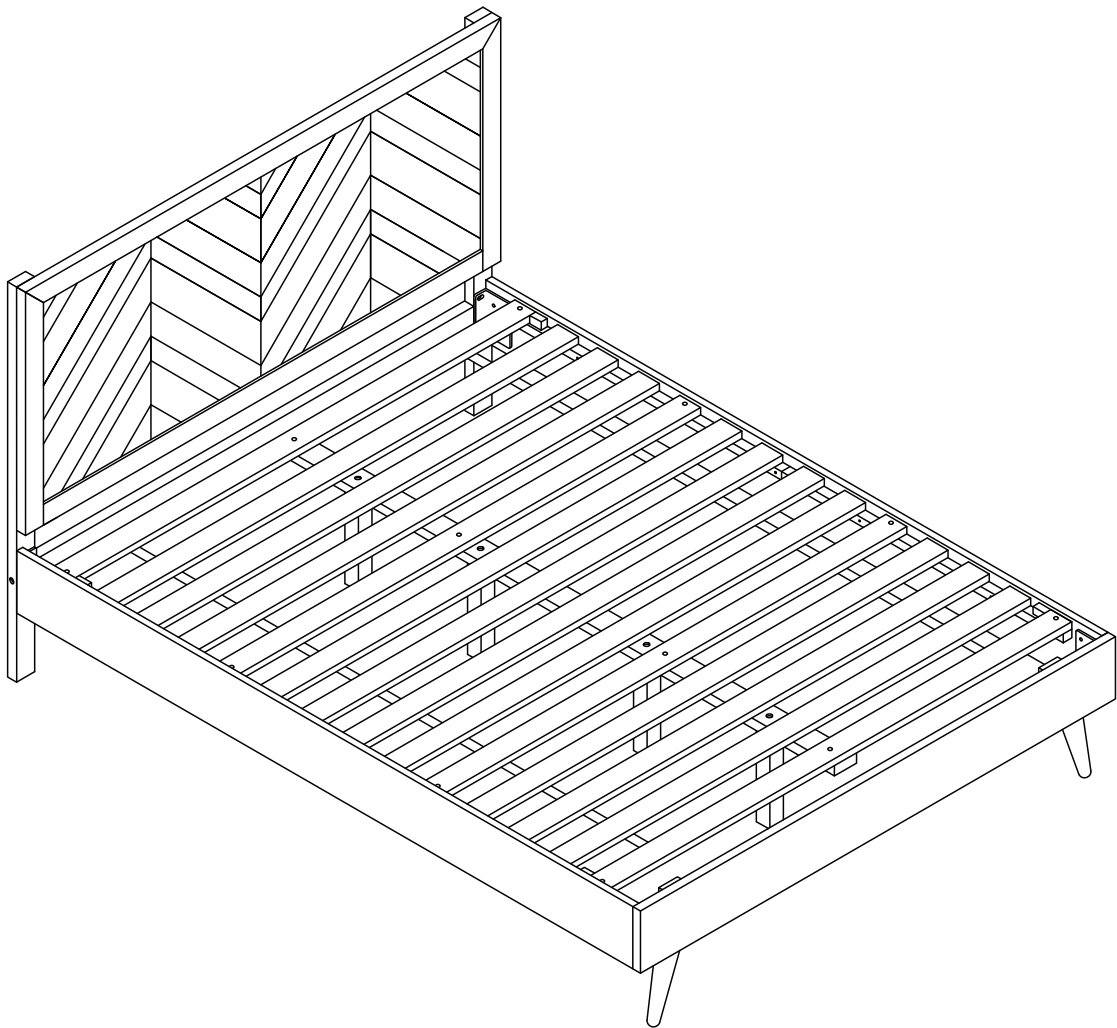

CHEVRON BED

BEFORE YOU BEGIN

Save all packaging materials until product is fully assembled. Hardware and small pieces may not be seen and could be accidentally discarded with packaging materials.

Follow the instructions carefully as deviation from them may void your warranty and present a possible safety risk.

It is recommended that assembly is done on a soft surface like carpet to avoid damage.

CARE INSTRUCTIONS







Simply wipe with a damp cloth.

ENJOY YOUR NEW FURNITURE!





We take pride in hand crafting each product for our customers and strive to make your experience easy and enjoyable. From the entire team, we hope you enjoy your new piece of furniture!

PARTS LIST FOR CHEVRON BED

INCLUDED IN HARDWARE BAG

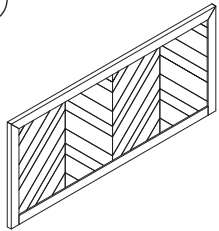
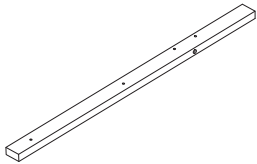
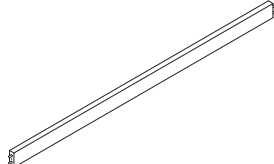
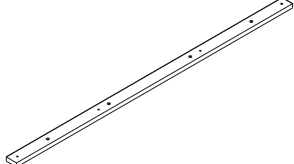
A x 8  M8x80 ALLEN BOLT	B x 16  M6x40 ALLEN BOLT	C x 2  M6x60 ALLEN BOLT	D x 8  WOOD SCREW	E x 8  FLAT WASHER	F x 1  ALLEN WRENCH (M8)
G x 1  ALLEN WRENCH (M6)	<p>PLEASE NOTE: A Phillips head screwdriver is required, but not included.</p>				

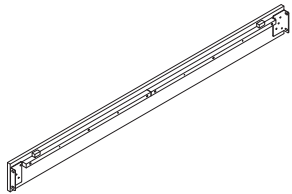
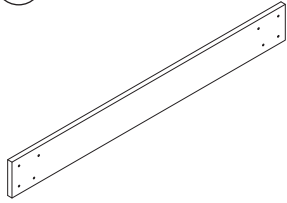
INCLUDED IN CARTON

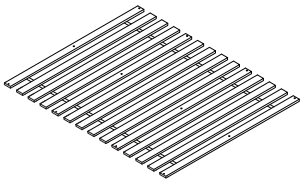
H x 1  HEADBOARD PANEL	I x 2  HEADBOARD LEG	J x 1  HEADBOARD RAIL	K x 1  SUPPORT BEAM
L x 4  SUPPORT LEGS	M x 2  SIDE RAIL	N x 1  FOOTBOARD RAIL	O x 2  FOOTBOARD LEGS
P x 1  BED SLATS			

SAVE ALL PACKAGING MATERIALS UNTIL PRODUCT IS FULLY ASSEMBLED. HARDWARE AND SMALL PIECES MAY NOT BE SEEN AND COULD BE ACCIDENTALLY DISCARDED WITH PACKAGING MATERIALS.

ASSEMBLY INSTRUCTIONS FOR **CHEVRON BED**

STEP 1

First, connect the headboard legs (I) to the headboard rail (J) with the longest M6 allen bolts (C), first finger tightening both bolts and then securing with the M6 allen wrench (E).

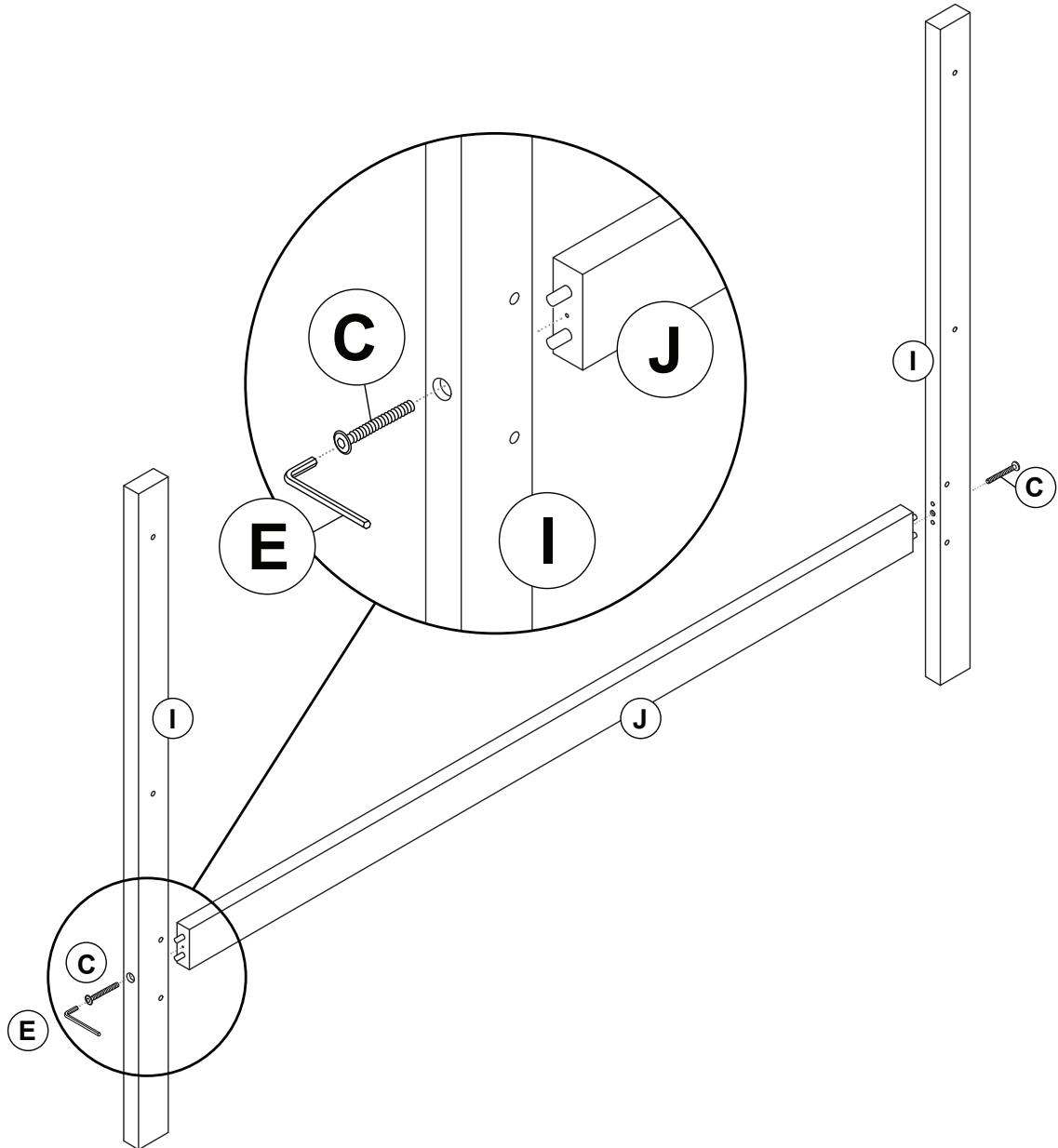

ASSEMBLY INSTRUCTIONS FOR **CHEVRON BED**

STEP 2

Then, connect the headboard panel (H) to the headboard legs (I) with four medium M6 allen bolts (B), first finger tightening all four bolts and then securing with the M6 allen wrench (E).

Note: Insert the bolts into the topmost holes (1) on headboard panel (H) for a headboard height of 45". Insert the bolts into the lower holes (2) for a headboard height of 48".

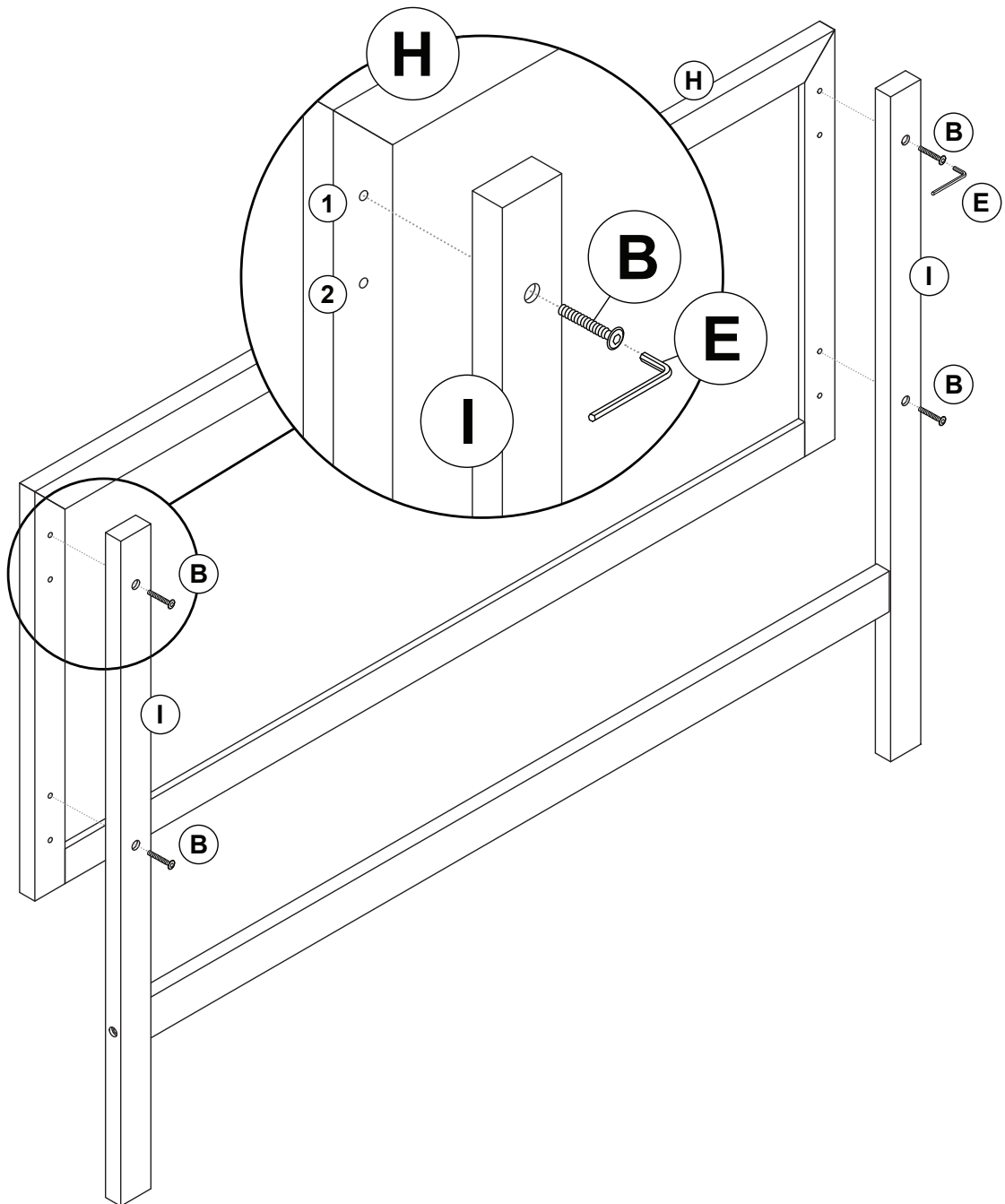

ASSEMBLY INSTRUCTIONS FOR **CHEVRON BED**

STEP 3

Attach the headboard legs (O) to the footboard rail (N) with four medium M6 allen bolts (B), first finger tightening all four bolts and then securing with the M6 allen wrench (E).

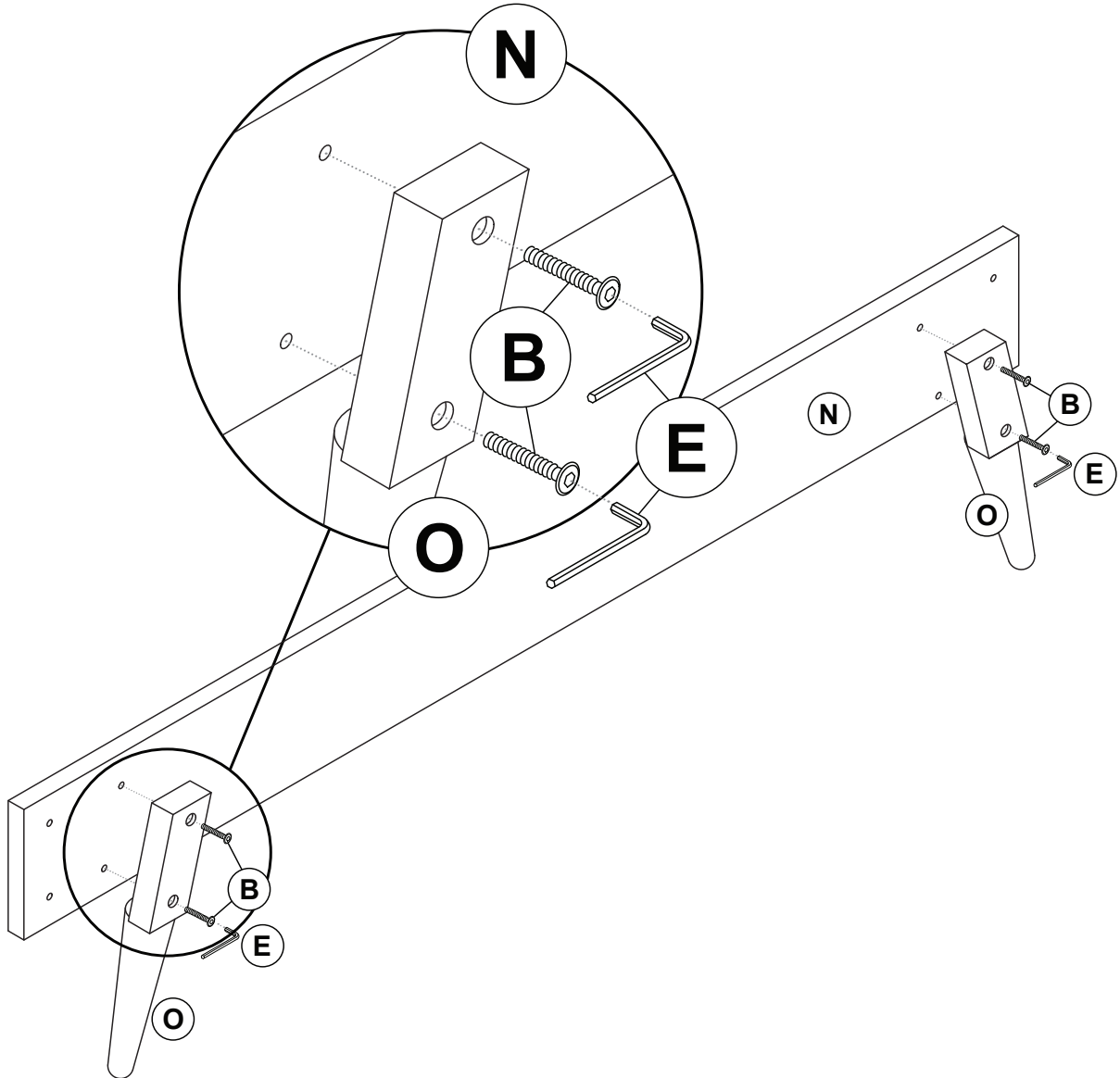

ASSEMBLY INSTRUCTIONS FOR **CHEVRON BED**

STEP 4

Attach the support beam (K) to the support legs (L) one at a time, using four medium M6 allen bolts (B), first finger tightening and then securing with the M6 allen wrench (E).

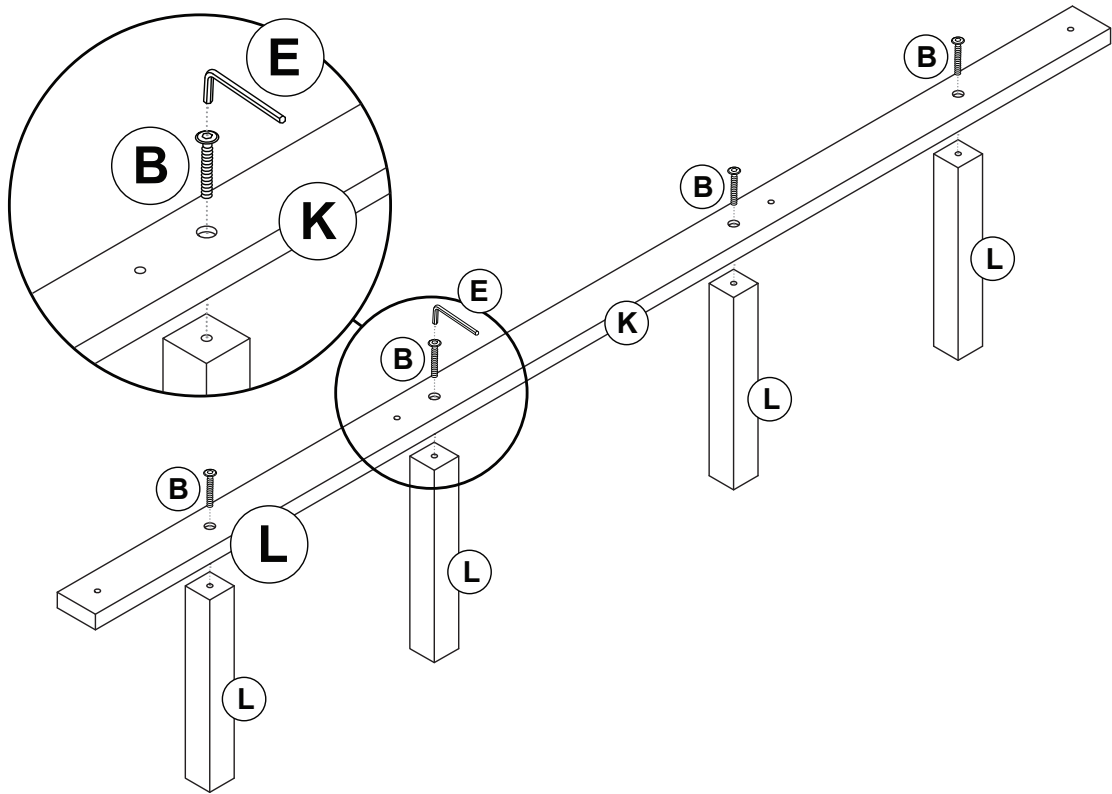

ASSEMBLY INSTRUCTIONS FOR **CHEVRON BED**

STEP 5

Attach bed slats (P) to the support rail (K) using four medium M6 allen bolts (B), first finger tightening and then securing with the M6 allen wrench (E).

NOTE: Be sure that the slat webbing straps are on the bottom of the slats before securing.

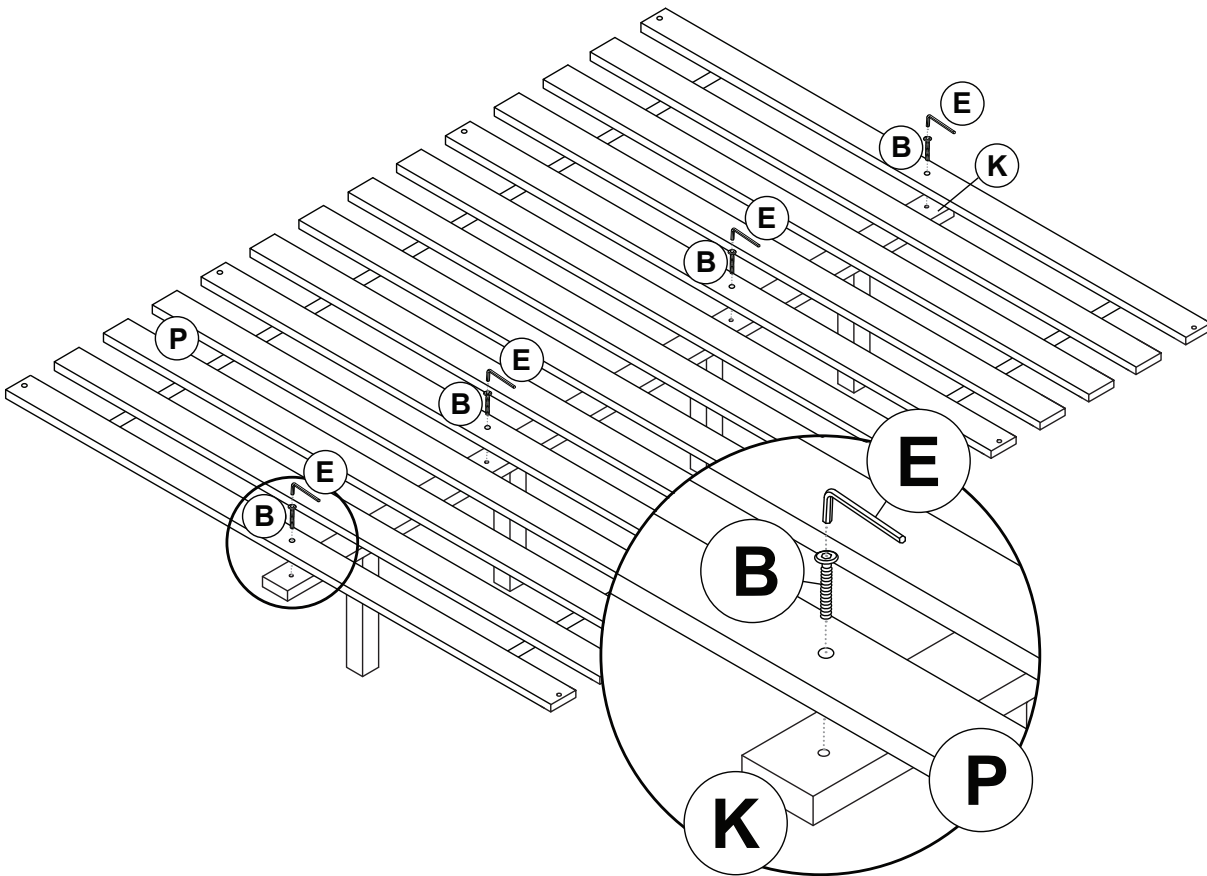

ASSEMBLY INSTRUCTIONS FOR **CHEVRON BED**

STEP 6

One side at a time, attach the side rails (M) to the headboard legs (I) using four M8 allen bolts (A), each threaded with a flat washer (E). Finger tighten each bolt first and then secure with the M8 allen wrench (G).

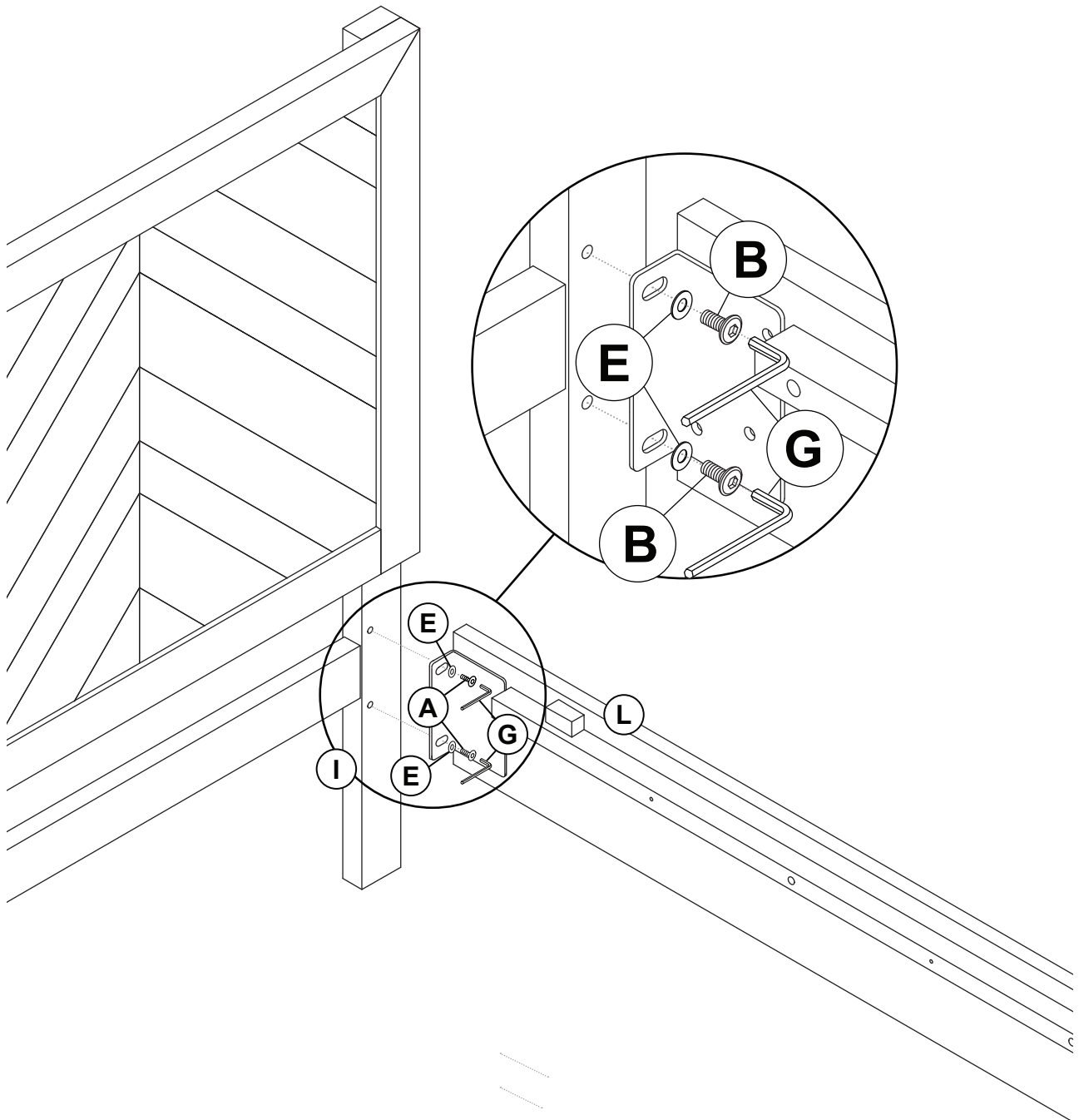

ASSEMBLY INSTRUCTIONS FOR **CHEVRON BED**

STEP 7

Then, one side at a time, attach the side rails (M) to the footboard (N) using four M8 allen bolts (A), each threaded with a flat washer (E). Finger tighten each bolt first and then secure with the M8 allen wrench (G).

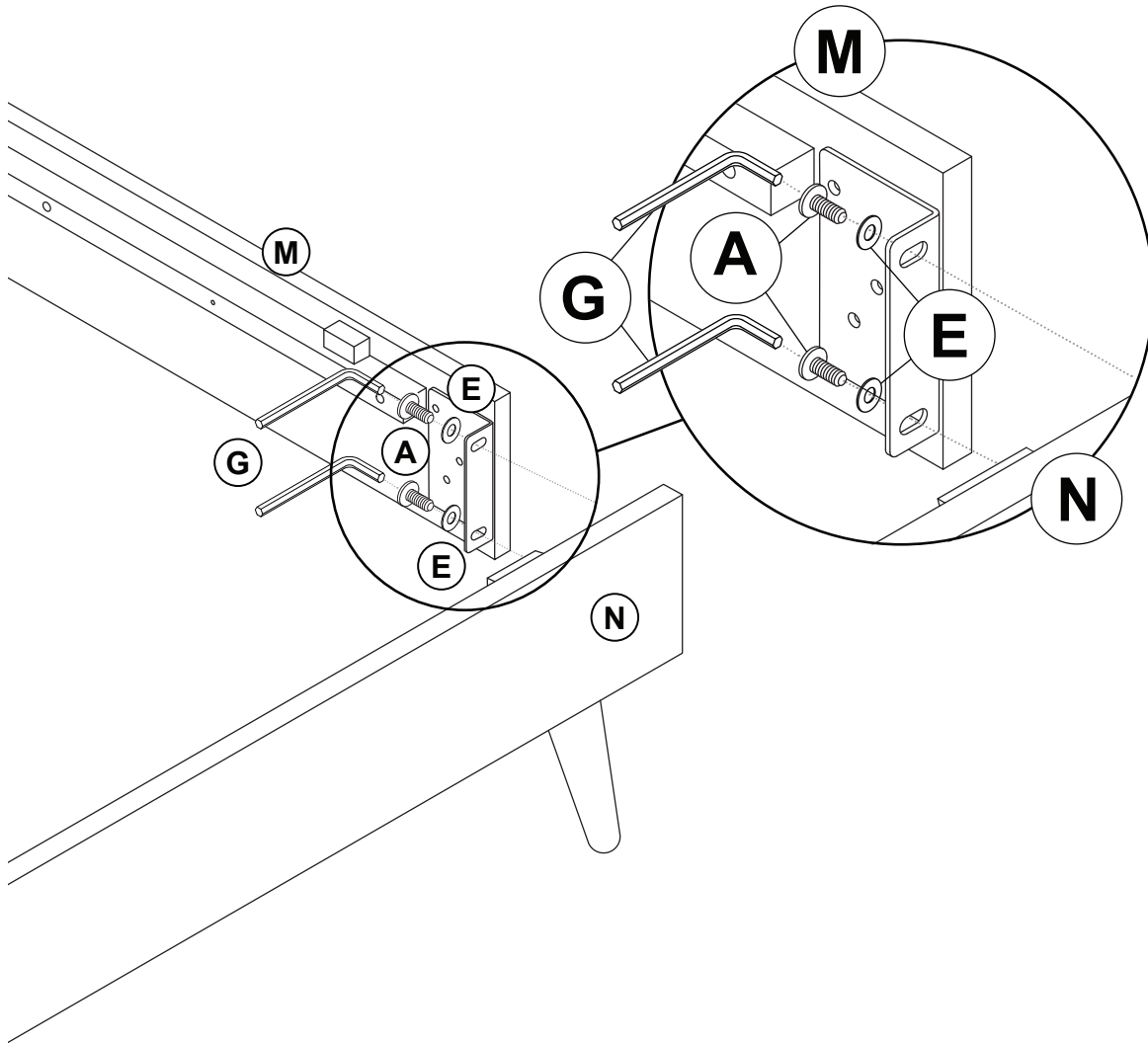

ASSEMBLY INSTRUCTIONS FOR **CHEVRON BED**

STEP 8

Place the slats (K) into the assembled bed frame, using eight wood screws (D) to secure the slats to the side rails (M) through the pre-drilled holes in four of the slats.

NOTE: You will need to use a phillips head screwdriver (not included) for this step.

