

ASSEMBLY INSTRUCTION

SKU CODE: N709P182409A / N709P182410A
N709P182411A / N709P182412A

INSTRUCTIONS DE MONTAGE

CODE UGS :N709P182409A / N709P182410A
N709P182411A / N709P182412A

**This set included 2 boxex if do not receive full 2
boxex. Please contact our customer service team**

**Cet ensemble comprenait 2 boxex si vous ne
recevez pas 2 boxex complets. Veuillez contacter
notre service client**

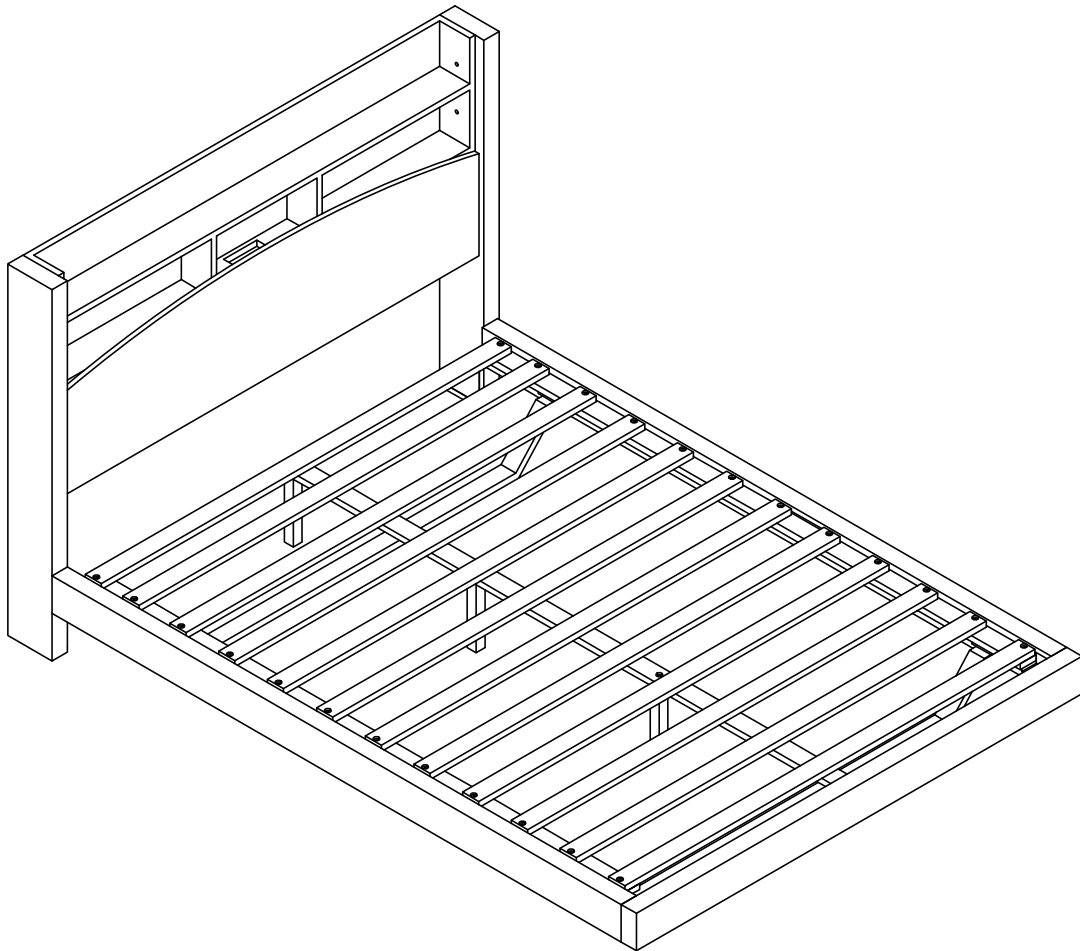

CAUTION : YOU MUST READ THIS BEFORE YOU PROCEED



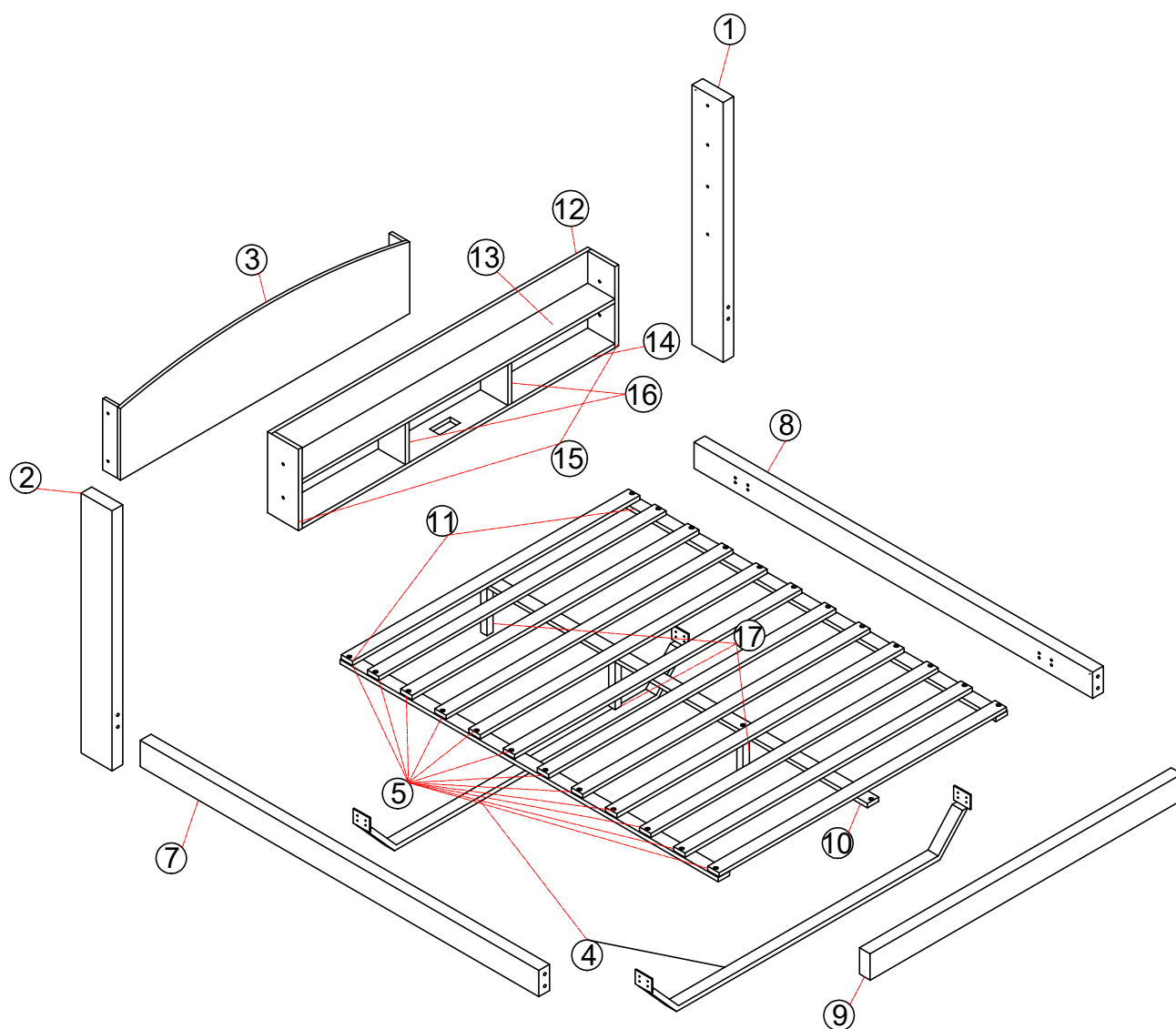

AVERTISSEMENT : VOUS DEVEZ LIRE CECI AVANT DE PROCÉDER



Part List (Liste des pièces)

BOX 1/2: N709P182409A/ N709P182411A

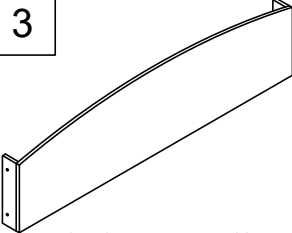
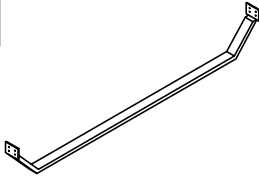
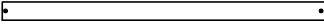
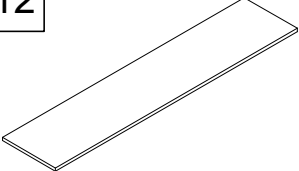
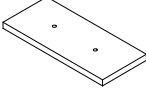
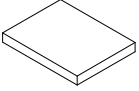
(ENCADRÉ 1/2 :N709P182409A/ N709P182411A)

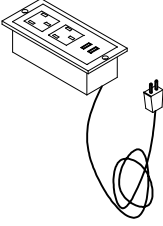
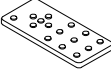
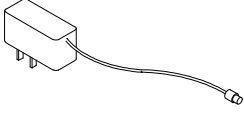
<p>1</p>  <p>LEFT BAR TOP -1PCS (BARRE HAUT GAUCHE- 1PCS)</p>	<p>2</p>  <p>RIGHT BAR TOP-1PCS (BARRE DROITE TOP-1PCS)</p>	<p>3</p>  <p>FRONT OF THE HEAD -1PCS (DEVANT LA TÊTE -1PCS)</p>	<p>4</p>  <p>HANGING LEGS-2PCS (PIEDS SUSPENDUS-2PCS)</p>
<p>5</p>  <p>SLATES-7PCS (BARRES DE SUPPORT - 7 PCS)</p>	<p>12</p>  <p>BACK OF THE BOX 01PCS (ARRIÈRE DE LA BOÎTE - 1 PCS)</p>	<p>15</p>  <p>HIP BOX-2PCS (BOÎTE DE HANCHE - 2 PCS)</p>	<p>16</p>  <p>SUPPORT IN THE MIDDLE OF THE BOX- 02 PCS (SUPPORT AU MILIEU DE LA BOITE - 2 PCS)</p>
<p>17</p>  <p>LEGS MIDDLE-3PCS (JAMBES MILIEU-3PCS)</p>	<p>18</p>  <p>POWER SOCKET-1PCS (PRISE -1PCS)</p>	<p>19</p>  <p>CONTROL-1PCS (CONTRÔLE-1PCS)</p>	<p>20</p>  <p>LINK HEAD-1PCS (TÊTE DE LIEN-1PCS)</p>

BOX 2/2: N709P182410A/ N709P182412A



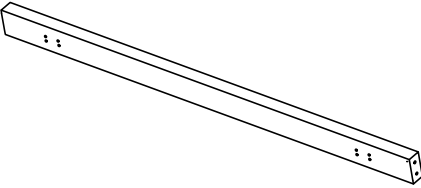
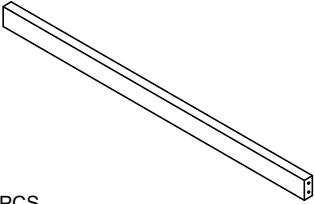
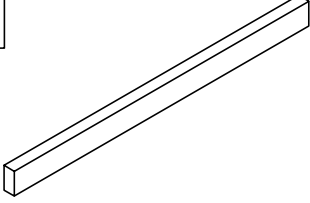
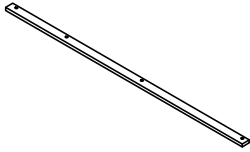
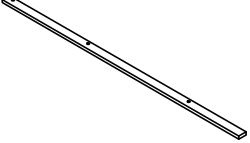
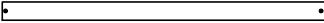
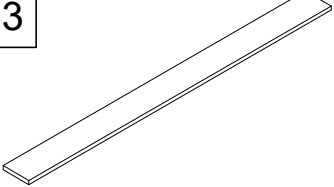
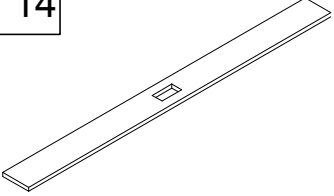
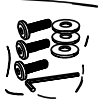











(ENCADRÉ 1/2 :N709P182410A/ N709P182412A)

<p>7</p>  <p>LEFT BED SIDE - 1PCS (CÔTÉ GAUCHE DU LIT - 1PCS)</p>	<p>8</p>  <p>RIGHT BED SIDW - 1PCS (CÔTÉ LIT DROIT - 1PCS)</p>		
<p>9</p>  <p>END OF THE BED-1PCS (BOUT DU LIT-1PCS)</p>	<p>10</p>  <p>MIDDLE BED SUPPORT-1PCS (SUPPORT DE LIT MOYEN-1PCS)</p>	<p>11</p>  <p>BED SUPPORT SLATES-2PCS (SUPPORT DE LIT ARDOISES-2PCS)</p>	
<p>5</p>  <p>SLATES-3PCS (BARRES DE SUPPORT - 3PCS)</p>	<p>13</p>  <p>MIDDLE BED SUPPORT-1PCS (SUPPORT DE LIT MOYEN-1PCS)</p>	<p>14</p>  <p>MIDDLE BED SUPPORT-1PCS (SUPPORT DE LIT MOYEN-1PCS)</p>	<p>Hardware (Matériel)</p> 

HARDWARE

Check that you've received
all hardware listed below.

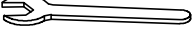
Hardware List (Liste du matériel)

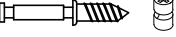
No.	OUTLOOK (PERSPECTIVES)	NOTE	QTY
(A)		Bolts 5/16"x60 mm (Boulons 5/16"x60 mm)	3
(B)		BULONG 2 HEADS 5/16"x 60 mm (BULONG 2 TÊTES 5/16"x60 mm)	8
(C)		Plain washer Ø5/16"x19x1.5 mm (Rondelle plate Ø5/16"x19x1.5 mm)	3
(D)		Spring washer Ø5/16"x12 mm (Rondelle élastiquer Ø5/16"x12 mm)	3
(E)		Allen key 80x25x4 mm (clé Alle n 80x25x4 mm)	1
(H)		Bolts 1/4"x45 mm (Boulons 1/4"x45 mm)	8
(I)		Bolts 1/4"x30 mm (Boulons 1/4"x30 mm)	46
(K)		Plain washer Ø1/4"x19x1.5 mm (Rondelle plate Ø1/4"x19x1.5 mm)	54
(L)		Spring washer Ø1/4"x10 mm (Rondelle élastiquer Ø1/4"x10 mm)	54
(M)		Metal base (Base de métal)	5
(N)		5/16"	8
(O)		Washer Ø5/16" Washer Ø5/16"	8
(P)		Wrench 5/16" (Clé 5/16")	1
(Q)		Screws Ø4x30 mm (Des vis Ø4x30 mm)	16
(F)		Screws Ø4x20 mm (Des vis Ø4x20 mm)	2
(R)		LINKING SCREWS (CONNEXION VISSÉE)	12

STEP 1 (ÉTAPE 1)

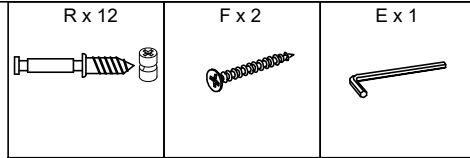

PUT THE DETAILED ACCESSORIES (R) IN THE CORRECT POSITION WHEN PERFORMING THE NEXT STEP
METTRE LES ACCESSOIRES DÉTAILLÉS (R) DANS LA POSITION CORRECTE LORS DE L'EXÉCUTION DES ÉTAPES SUIVANTES

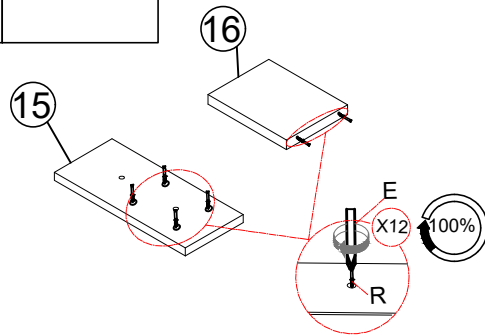

INSTALL ALL ACCESSORIES BEFORE ASSEMBLY
INSTALLEZ TOUS LES ACCESSOIRES AVANT L'ASSEMBLAGE

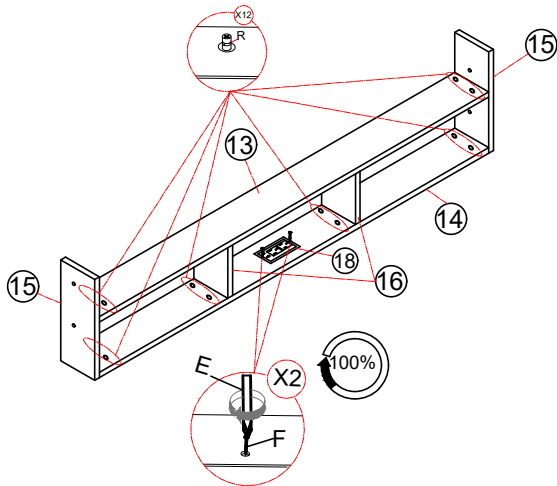

STEP 2 (ÉTAPE 2)

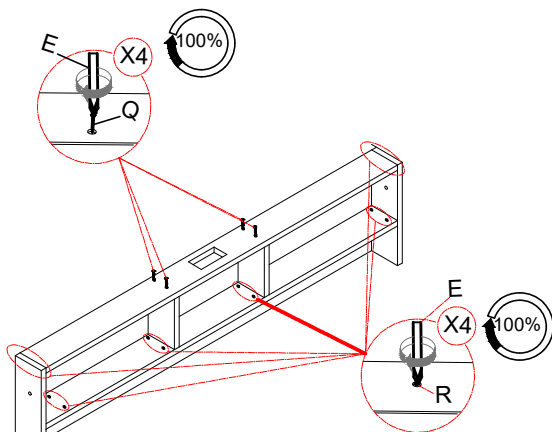
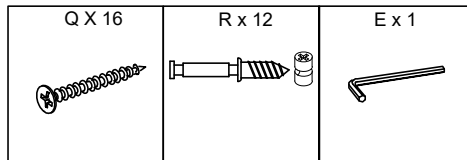



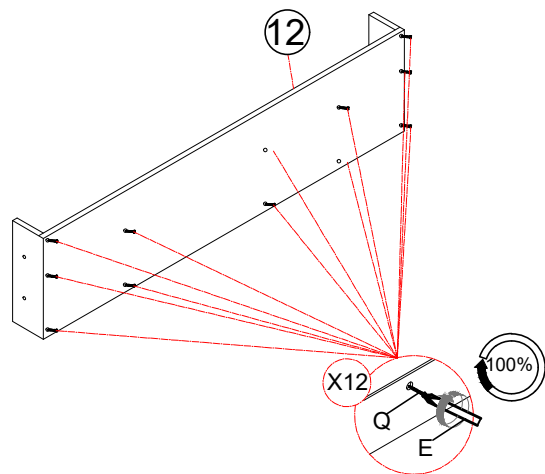

DETAILS Tighten (R)
DÉTAILS Serrer (R)



STEP 3



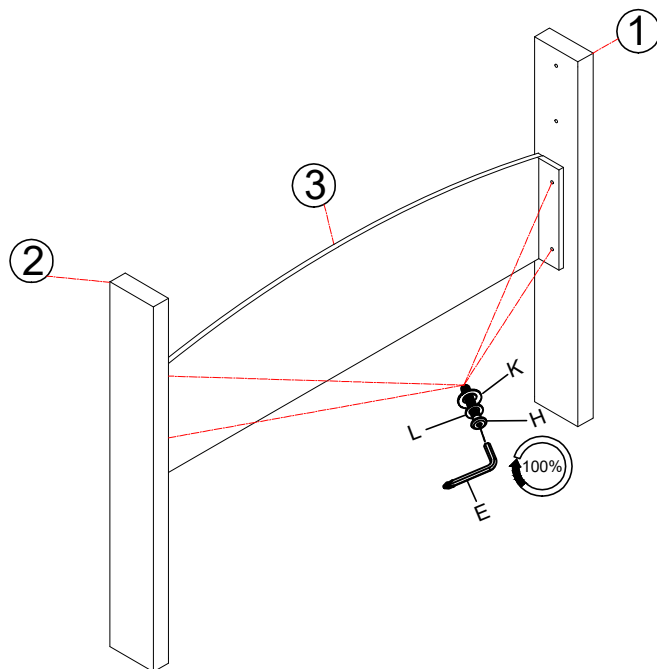

(ÉTAPE 3)

H x 4	K x 4	L x 4	E x 1
			



STEP 4

(ÉTAPE 4)

H x 4	K x 4	L x 4	E x 1	B x 4
				

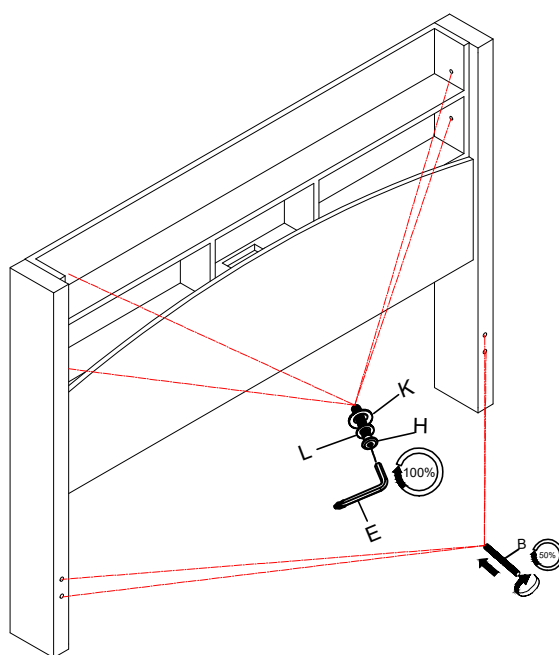

STEP 5

(ÉTAPE 5)

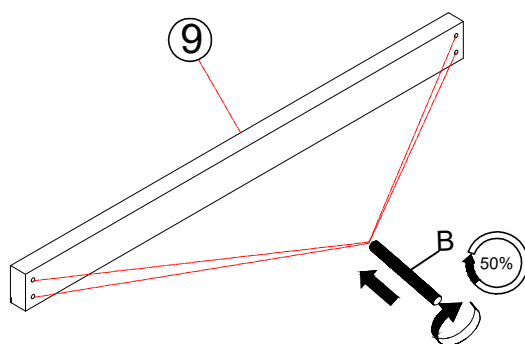
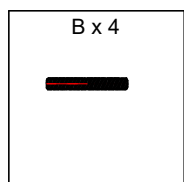



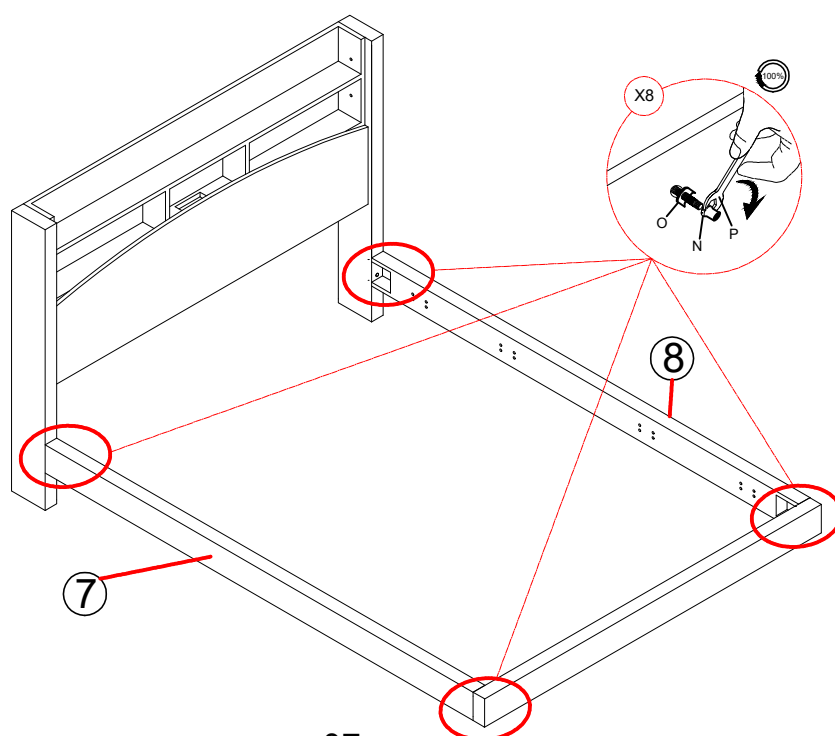
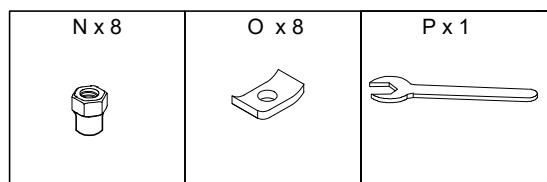

STEP 6

(ÉTAPE 6)



STEP 7



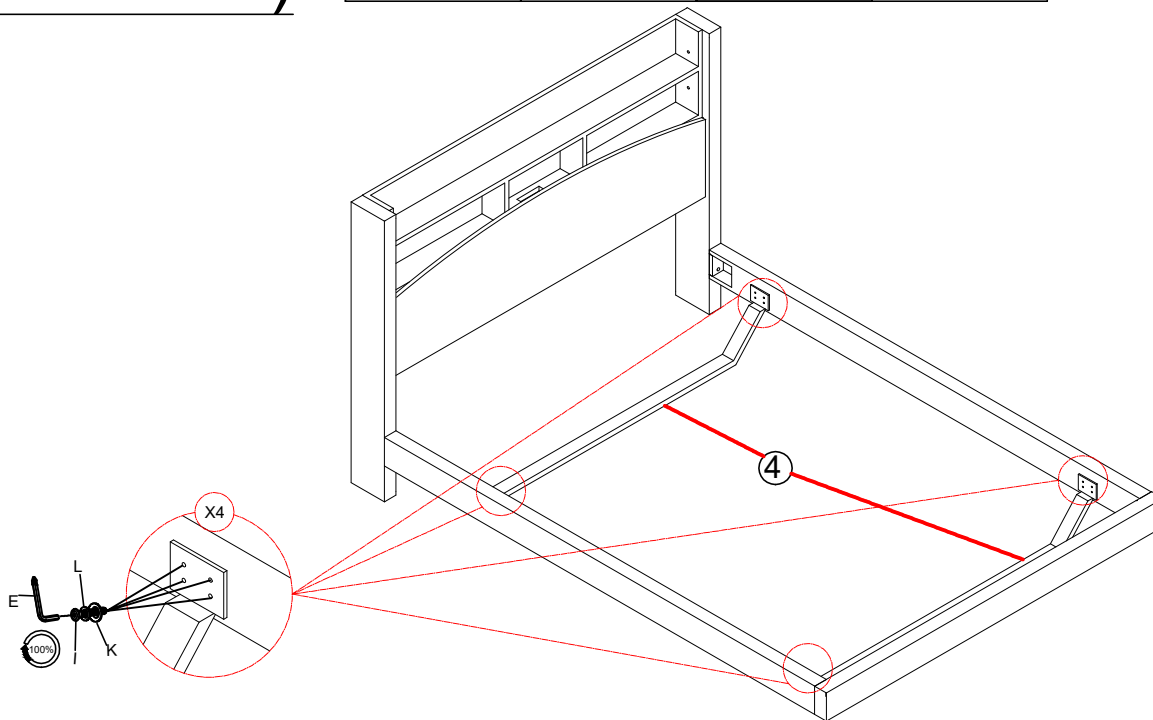

(ÉTAPE 7)

I x 16	K x 16	L x 16	E x 1
			



STEP 8

(ÉTAPE 8)

I x 10	K x 10	L x 10	M x 5	E x 1
				

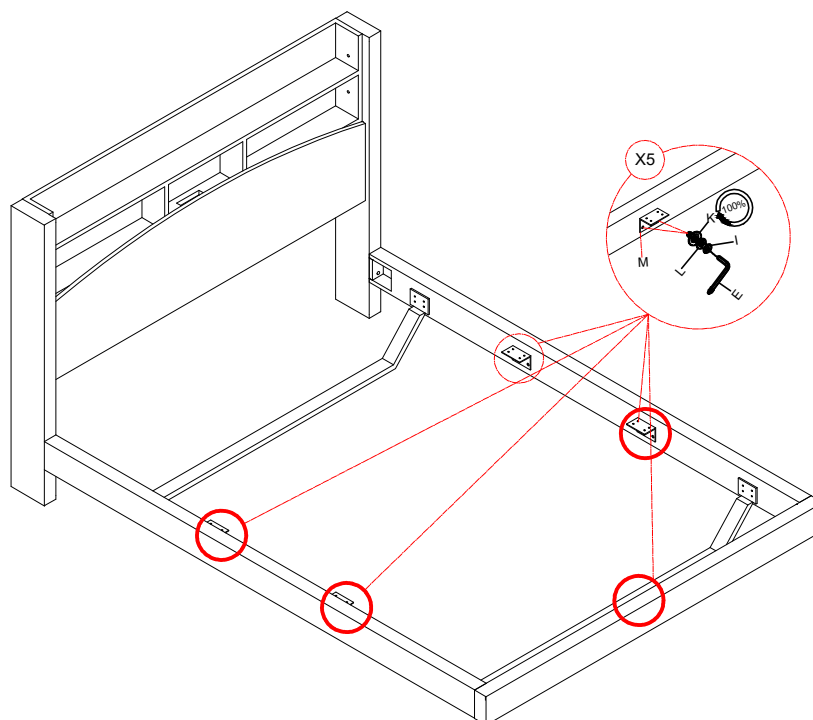



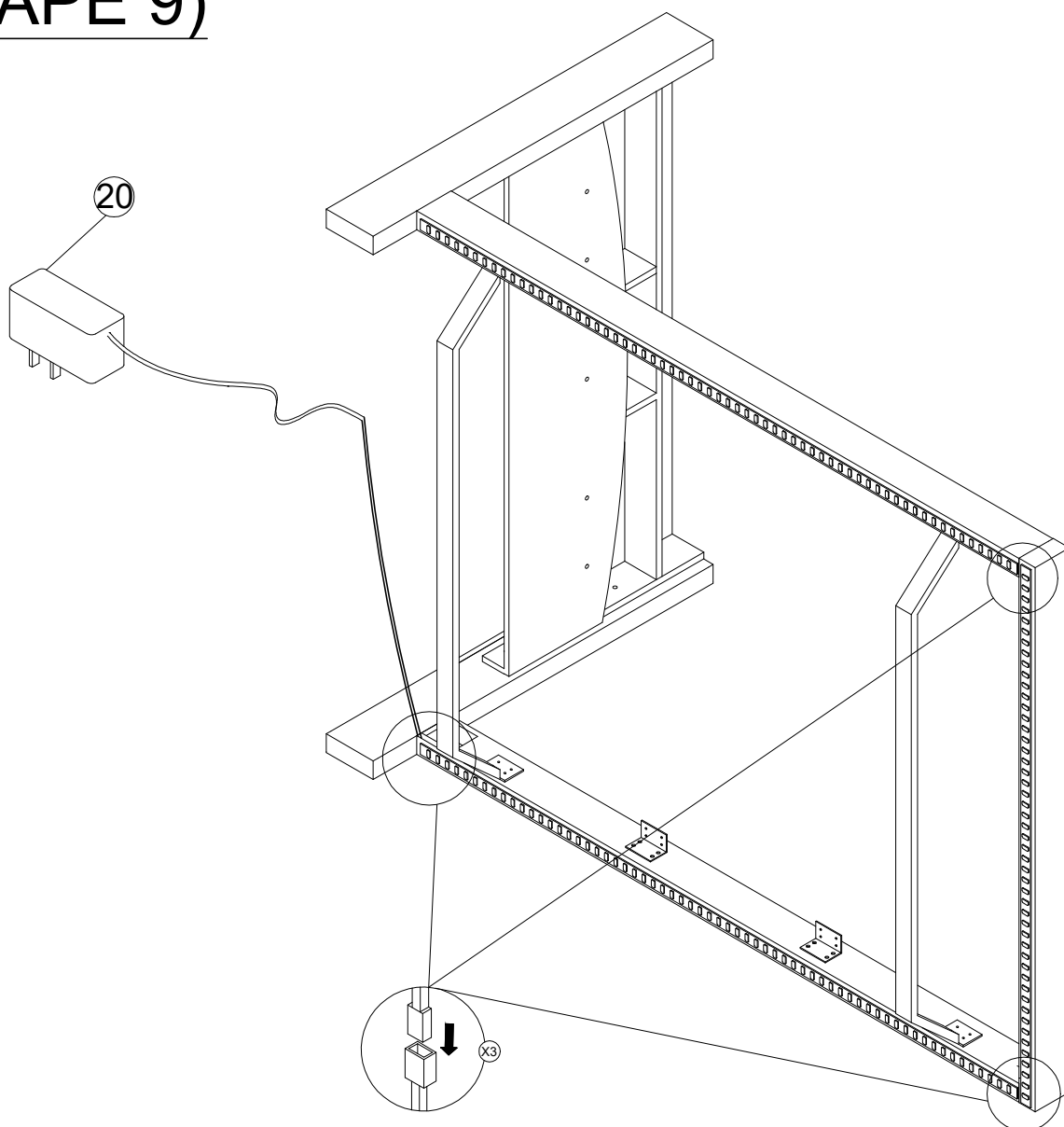

STEP 9

(ÉTAPE 9)





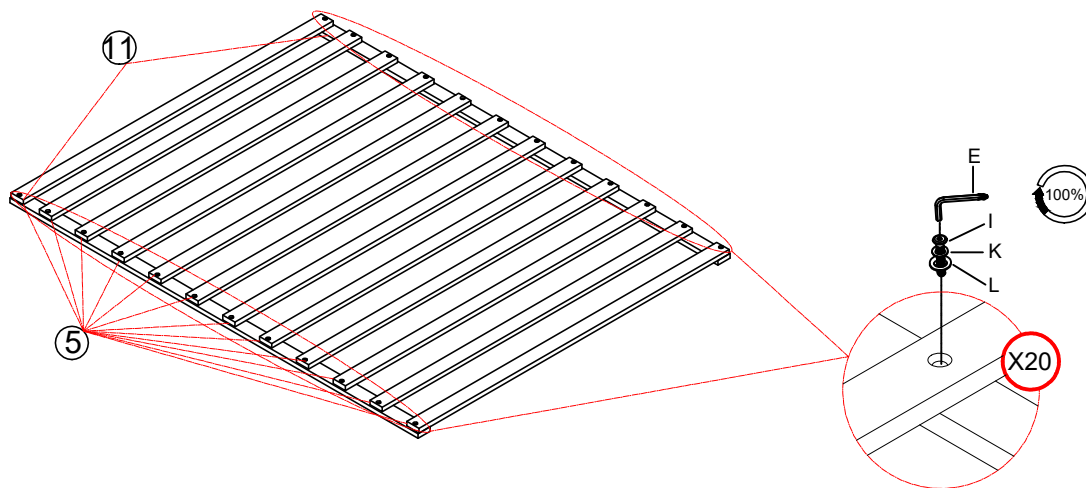

CONNECT ALL BULB LINKS
(CONNECTER TOUS LES LIENS D'AMPOULE)

STEP 10 (ÉTAPE 10)

I x 20	K x 20	L x 20	E x 1
			



STEP 11 (ÉTAPE 11)

A x 3	C x 3	D x 3	E x 1
			

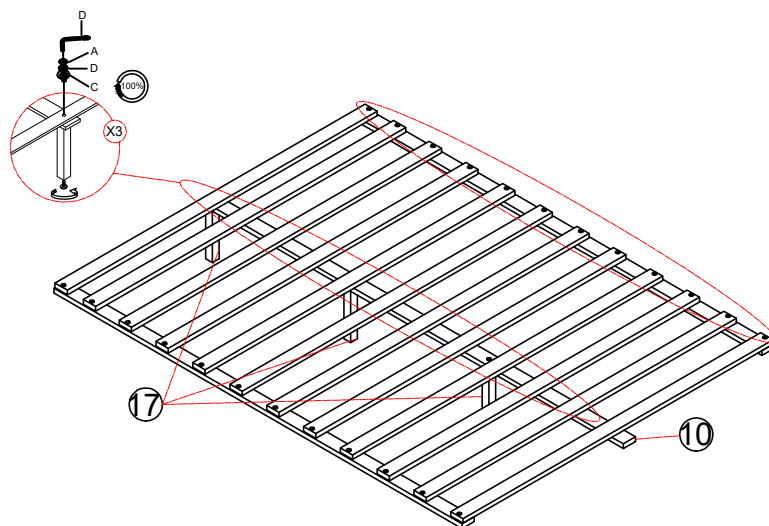

COMPLETE

(COMPLET)

