

Assembly Instructions

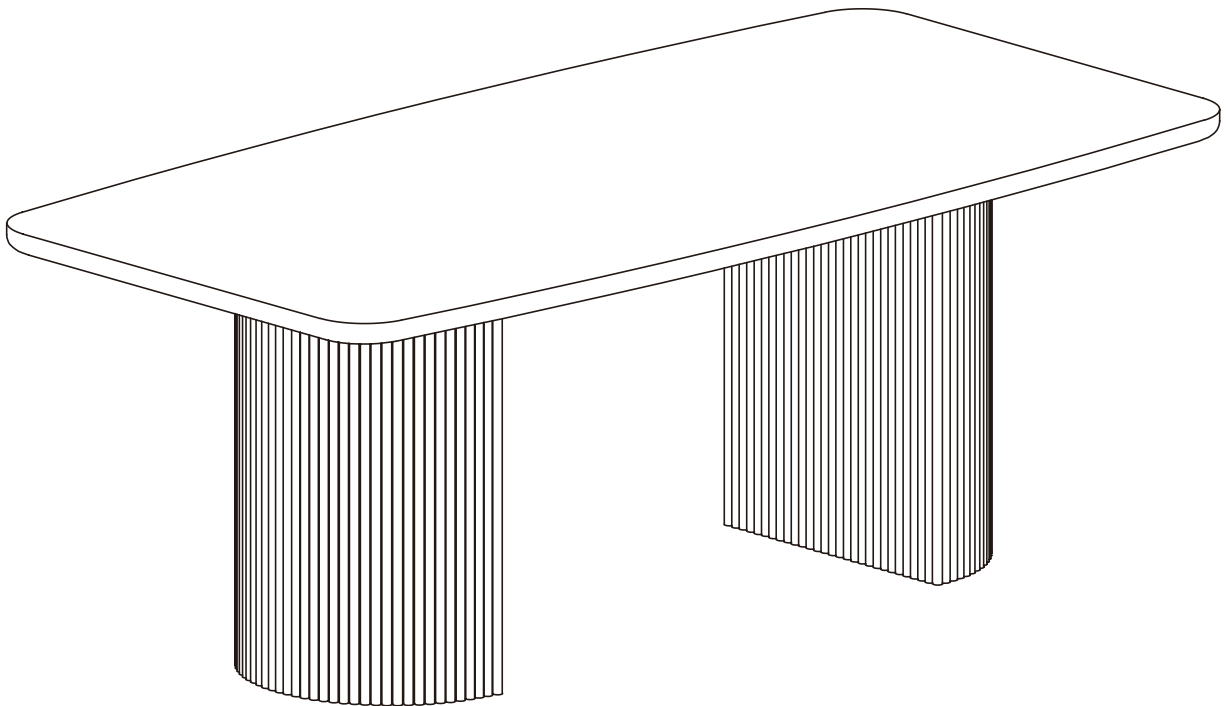

Dining Table

Model No.
HOGA- HL0150

Contact Us

We're here to help you.



Your satisfaction is our top priority. If you encounter any issues with this product, such as missing or damaged parts, we're here to help. Please retain the original packaging and take photos of the packaging and the product, then contact us as soon as possible.

Assembly Instructions:

1. Carefully read these instructions and keep them for future reference.
2. Refer to the parts list for guidance and ensure that you have all the pieces before starting the assembly process. If anything is missing, damaged, incorrect, contact us **FIRSTLY BEFORE** assembling.
3. When assembling, place all parts on a soft, clean, and flat surface, such as a carpet, to prevent any scratches.
4. To avoid misalignment of the holes, please don't fully tighten the screws until you've ensured all parts are in place.

Maintenance & Care:

1. Place the sintered stone dining table in a flat, dry, and well-ventilated area.
2. Avoid direct impact of sharp objects on the table top.
3. Do not place high-temperature objects directly on the sintered stone top. These include hot pots, kettles from stoves, or other high-temperature items from ovens or microwaves. Use pot stands with rubber feet or put heat-insulated pads to prevent damage.
4. For daily cleaning, gently wipe the surface with a soft damp cloth to remove grease and dirt.
5. Avoid cleaners containing acidic or abrasive ingredients, as they may damage the table.
6. It is not advisable to disassemble the sintered stone table. When moving it, multiple people should cooperate, and handle it gently.

⚠ Caution

Do not put items exceeding 130 lb on the table, or it would collapse.

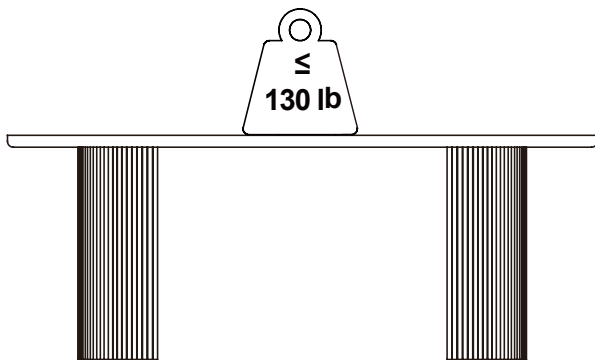

⚠ Caution

Do not sit or put pressure on one side of the table.

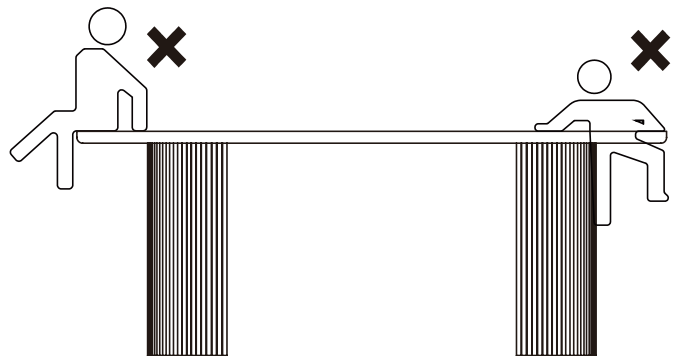

About Color Difference:

All product pictures are taken by our professional photographers, and colors are meticulously corrected and adjusted to be as consistent as possible with that of the actual items. However, different lighting, monitor settings, and individual interpretations may cause color differences. Besides, due to different cutting positions during the manufacturing process, there may be slight variations in patterns and colors on stone surfaces. Such issues do not fall under product quality problems.

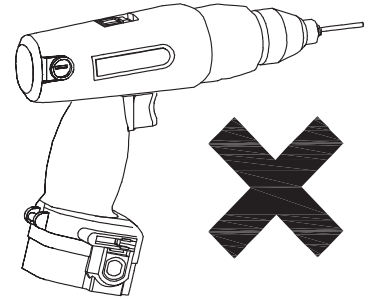
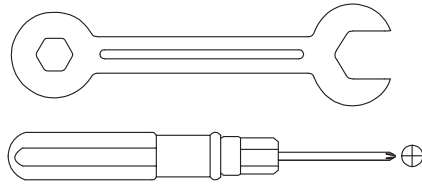
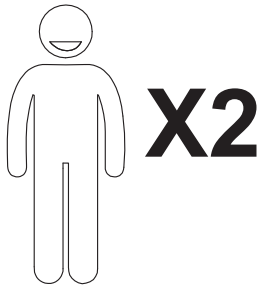

We recommend using hand tools for assembly.

If an electric screwdriver is used, reduce power and torque to avoid damage to the product.

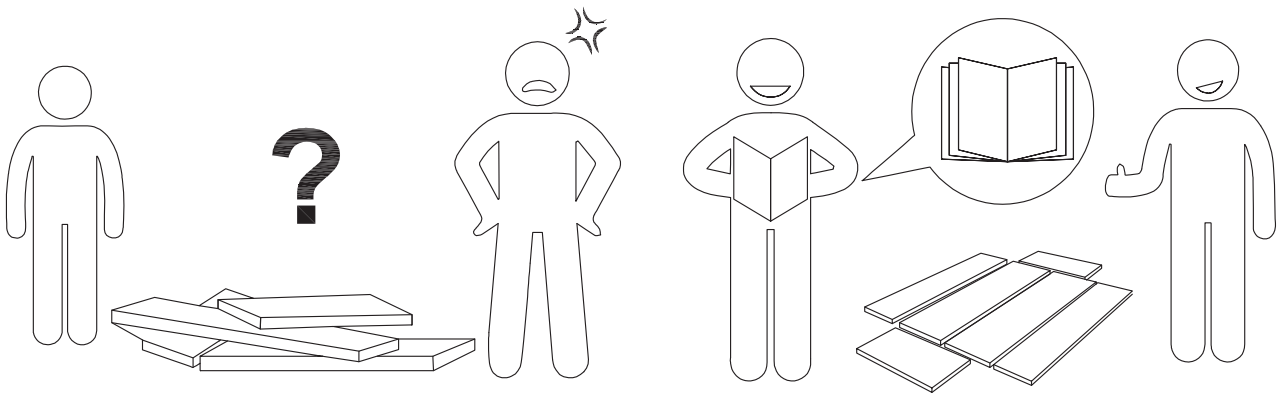

AVOID SCRATCHES

In order to avoid scratching, this furniture should be assembled on a soft surface, such as a rug.

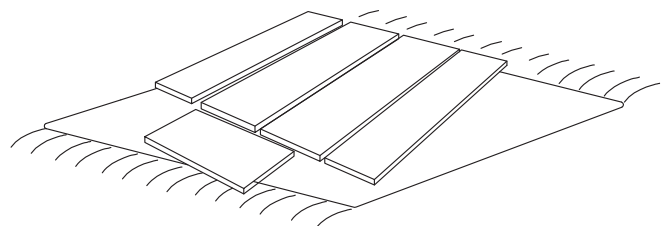
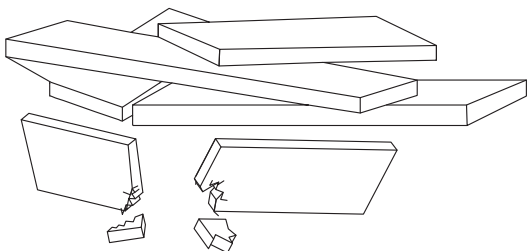

1. Use a hammer to carefully pry the battens apart.

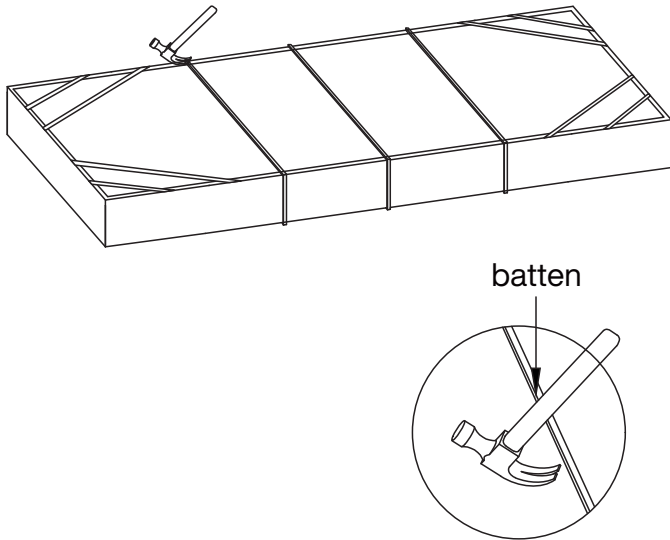

2. Take off the carton box cover, remove the EPE foam, and place it aside.

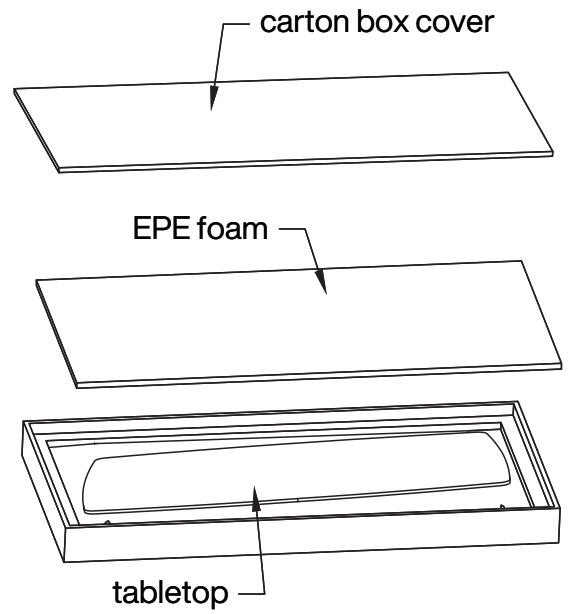

3. Four individuals are required to place the tabletop gently on the EPE foam with the sintered stone surface facing down to prevent potential damage.

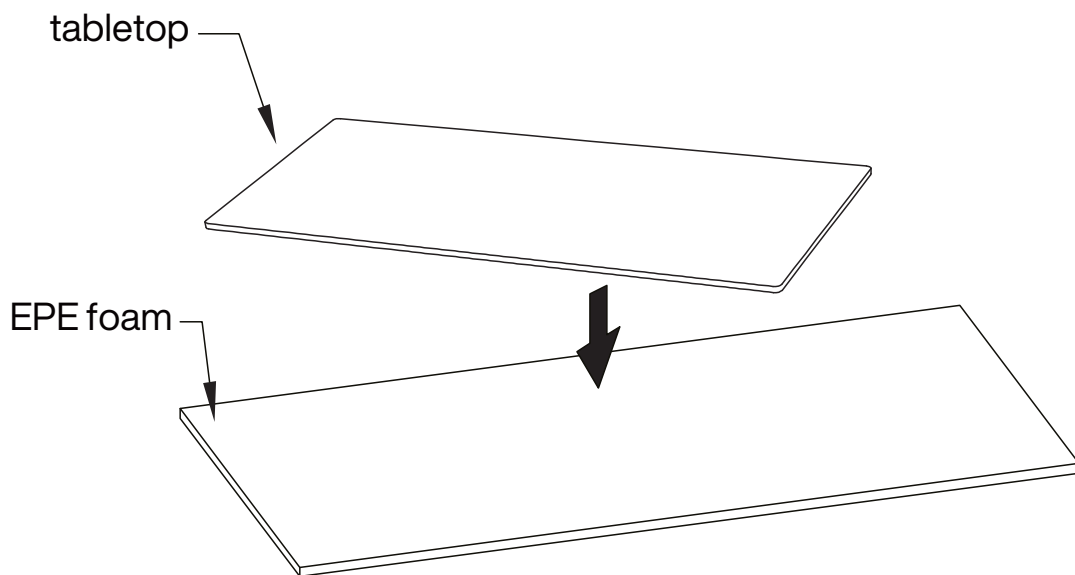

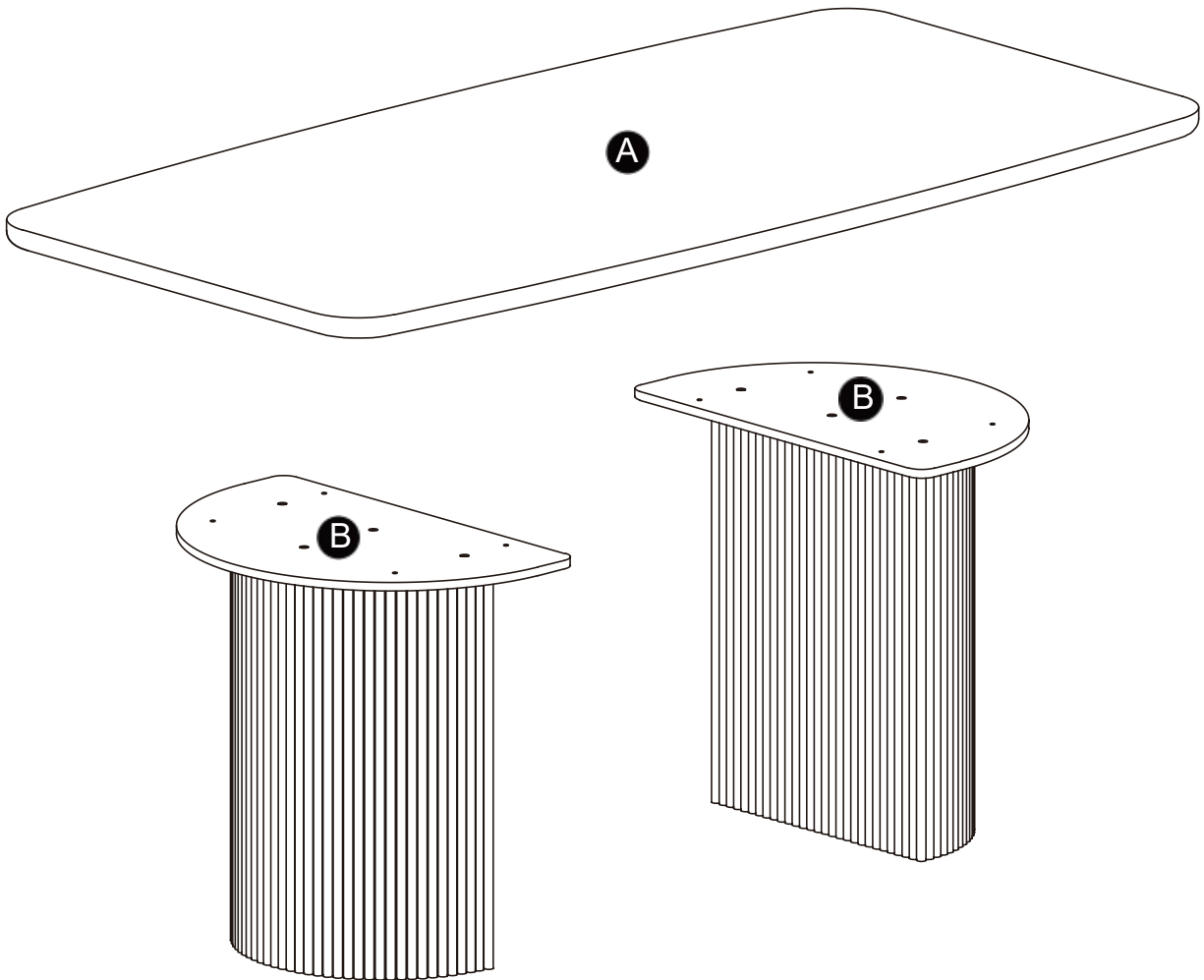



⚠ Caution

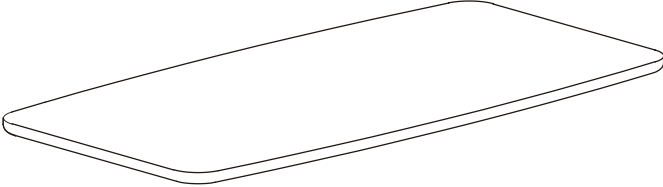
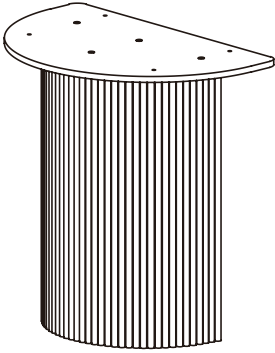

Make sure all parts are included. Most board parts are labeled or stamped on the raw edge. Contact us for a free replacement if you encounter any damaged or missing parts.

Part List

<p>A</p>  <p>1 pc</p>	<p>B</p>  <p>2 pcs</p>
---	--

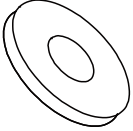
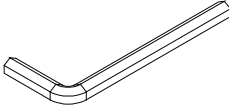
Hardware List

C	D	E	
 <p>M8x30mm</p>	 <p>M8</p>		
<p>8 pcs</p>	<p>8 pcs</p>	<p>1 pc</p>	

C	D
	
M8x30mm	M8
8 pcs	8 pcs

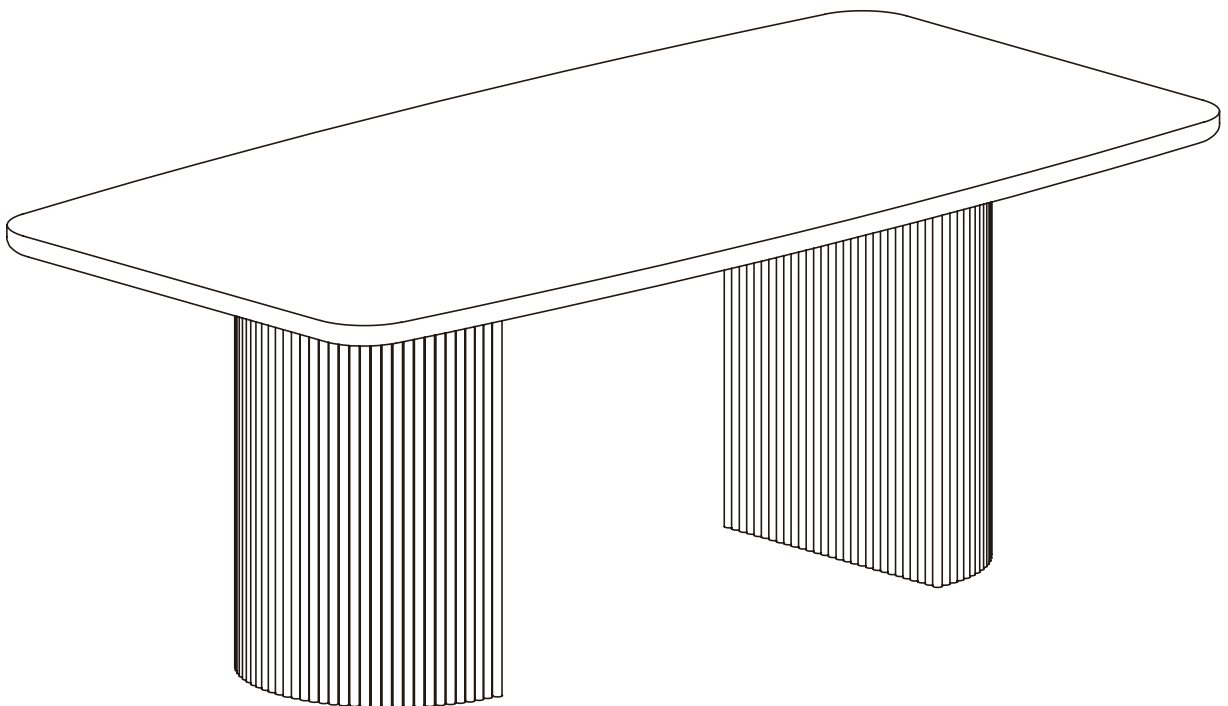
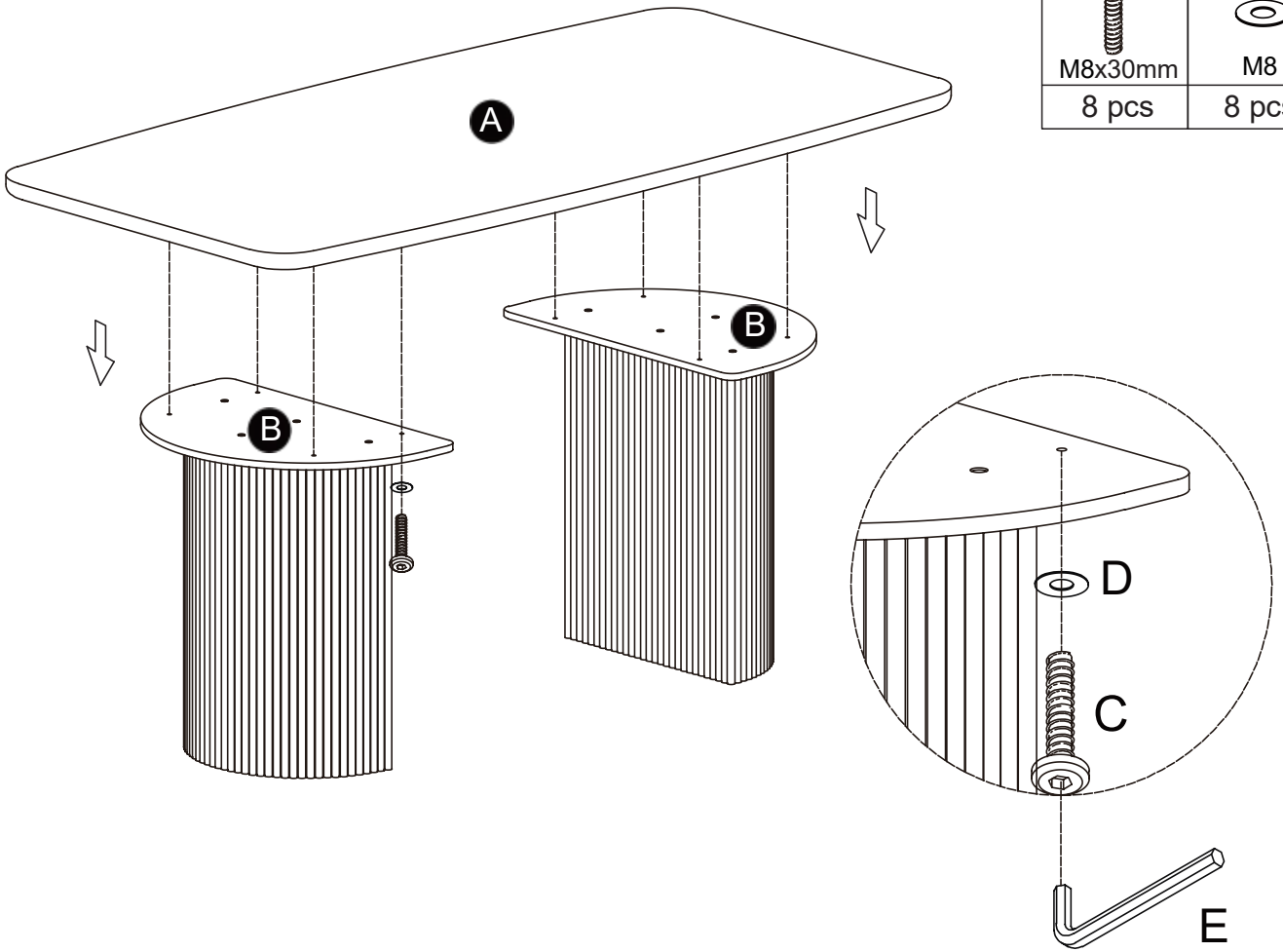

Thank you for your support!

