

## **Pay Attention:**









We strive to offer high-quality products, and we also try our best to satisfy each and every customer that orders from us with product or service as needed.

We would be grateful if you could take photos of defective parts and carton shipping marks for our reference after you check the products before assembling.

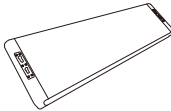
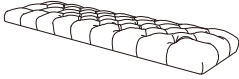
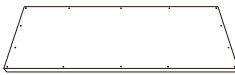
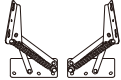
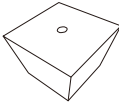
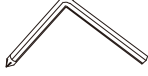
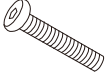
# ASSEMBLY INSTRUCTION

Thank you for purchasing this quality product. Be sure to check all the packing material carefully for small parts, which may have come loose inside the carton during shipment. Identify and count all parts and compare with the HARDWARE LIST below.

## PARTS LIST(NO TOOLS REQUIRED)

NO.	DESCRIPTION	PARTS	QTY	NO.	DESCRIPTION	PARTS	QTY
L	Left Panel		1	R	Right Panel		1
A	Front And Back Panels		2	B	Lid		1
C	Base Plate		1	D	Split Hinge		1
E	Legs		4	F	Allen Key		1
G	Screws	 M8*50MM	4	H	Screws	 M6*20MM	8
I	Self-tapping Screws	 M4*30MM	14	J	Flat Washers	 M6*Ø14MM	14
K	Felt Pads		4	M	Flat Washers	 M8*Ø16MM	4

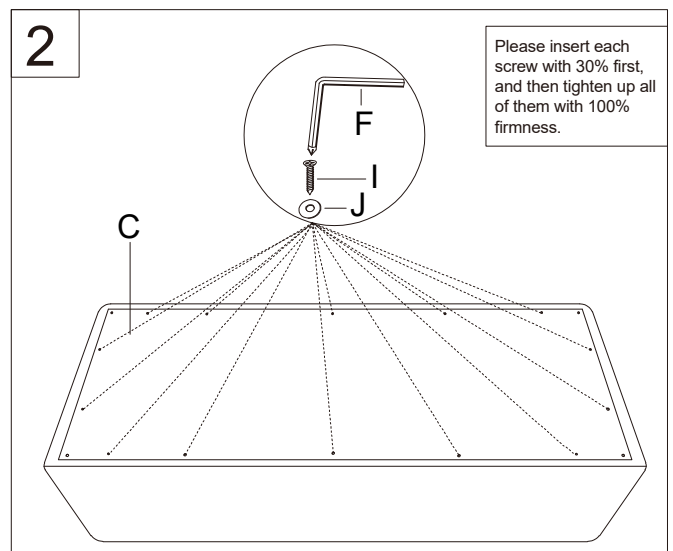
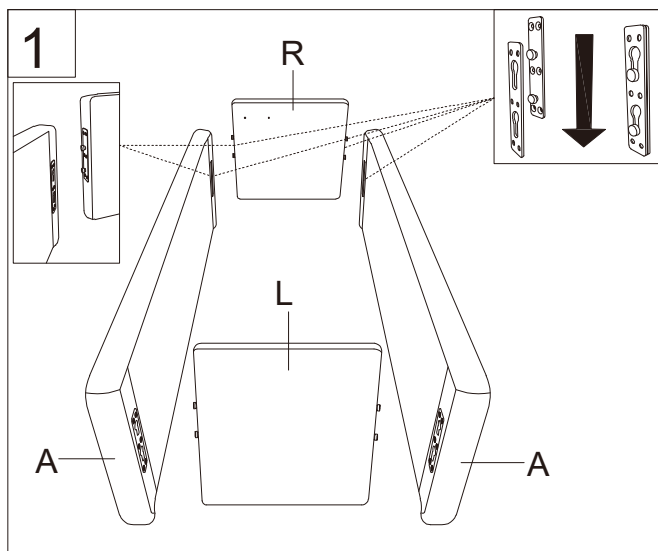

# ASSEMBLY INSTRUCTION

We would be grateful if you could take photos of defective parts and carton shipping marks for our reference after you check the products before assembling.

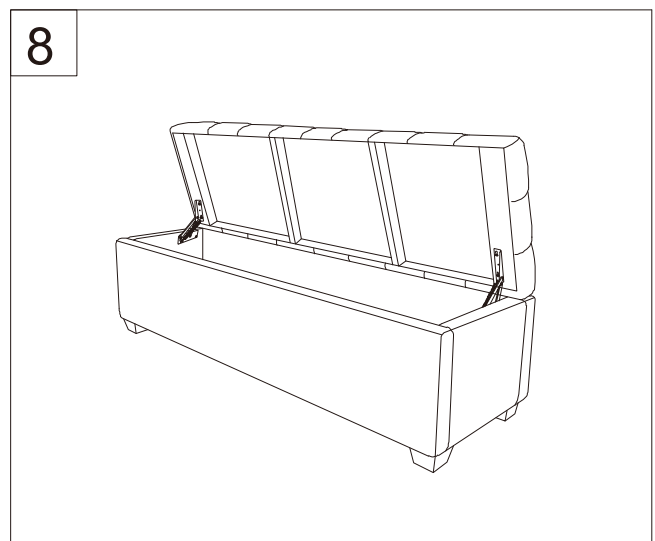
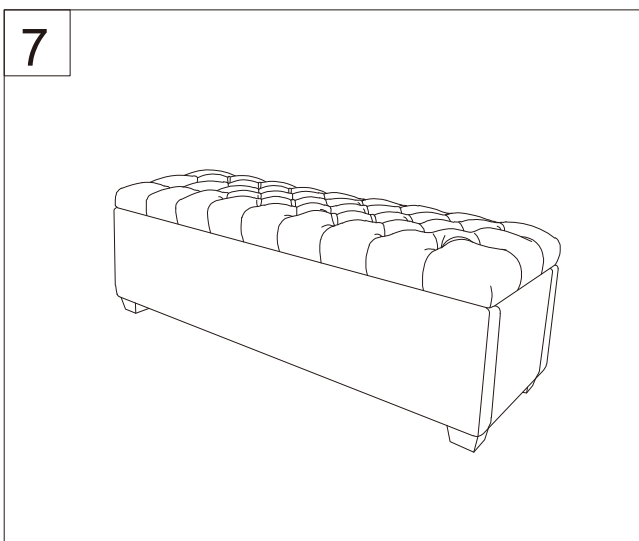
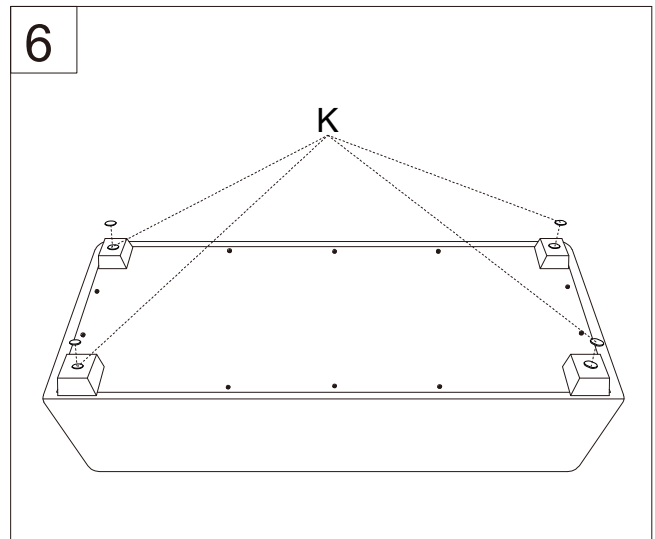
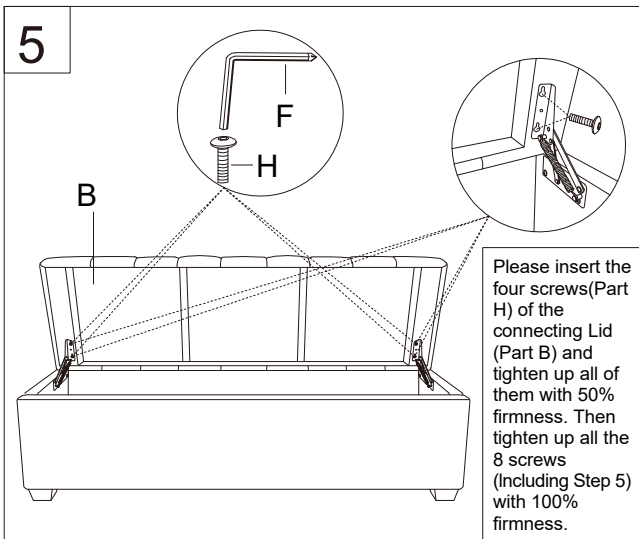
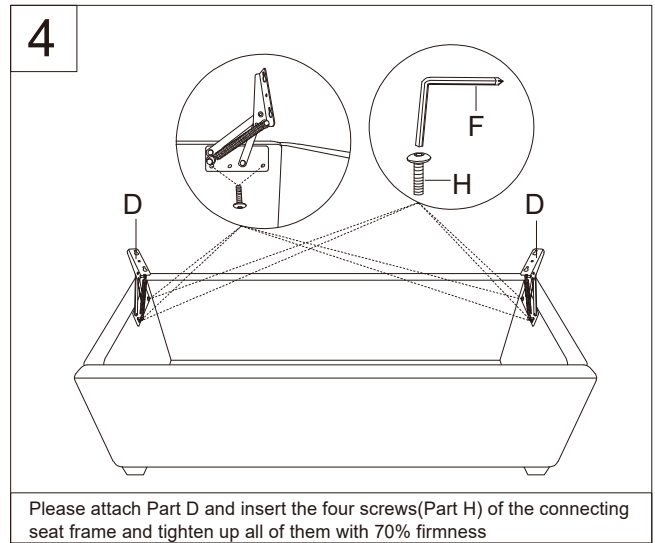
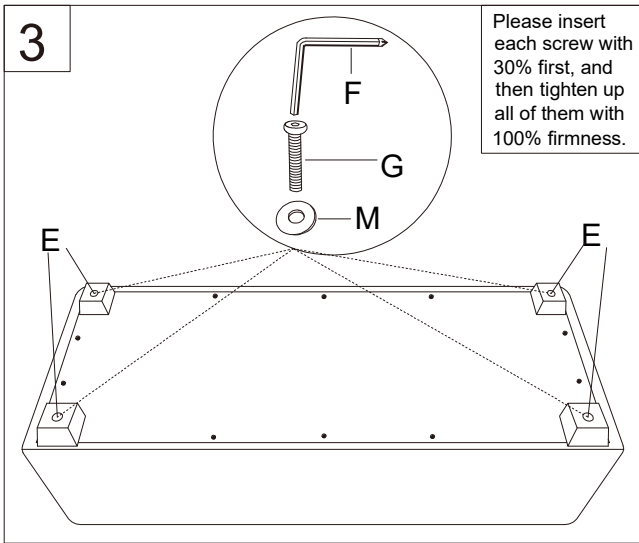

Hardware Pack Location: In the corner of inside carton.

Please don't throw away the original package if you insist to return the products.