

Round Dining Table

Instruction Manual

Mesa de comedor redonda

Manual de instrucciones

Table de Salle à Manger Ronde

Manuel d'Instruction

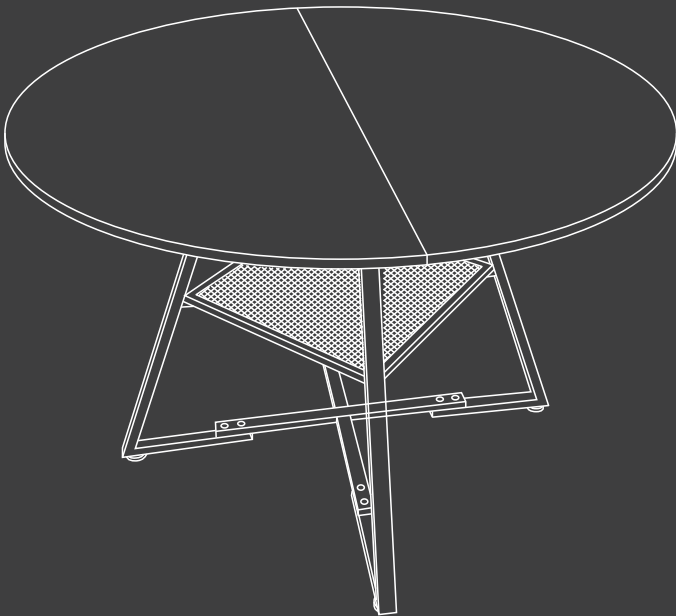

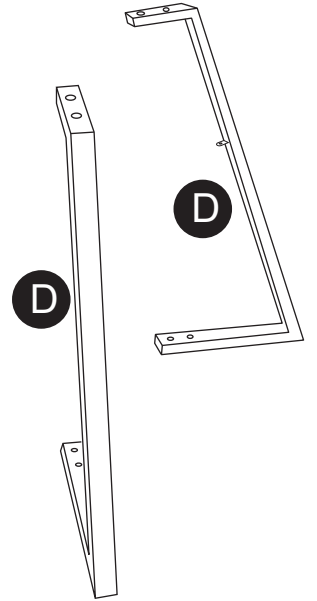
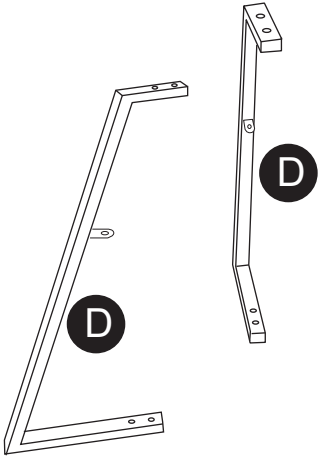
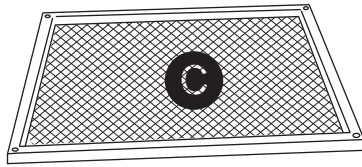
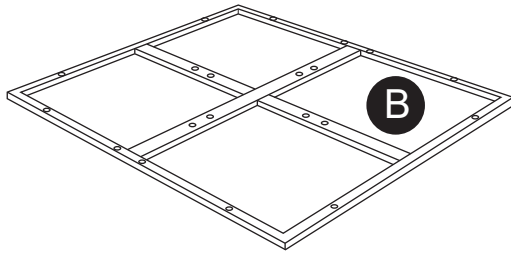
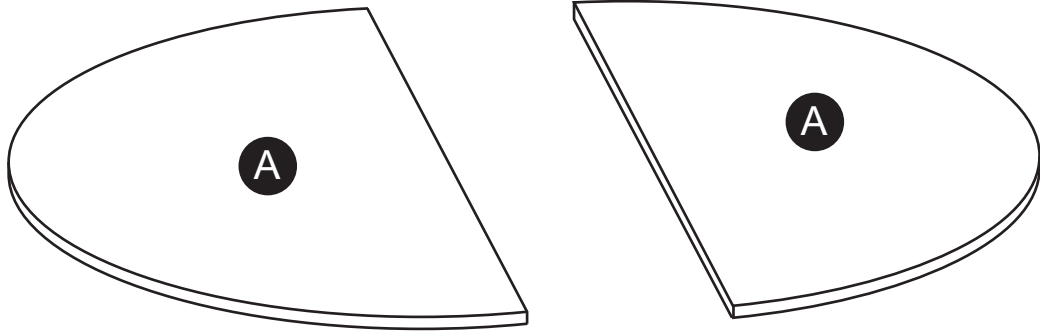

A X2

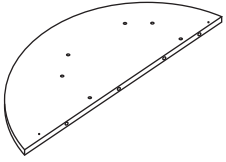

B X1

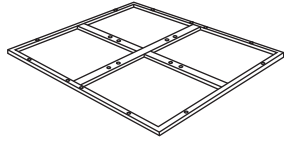

C X1

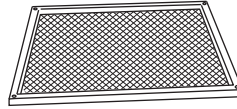

D X4

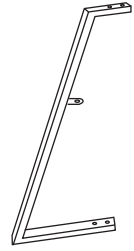

E X2



F X4



G X2



H X4

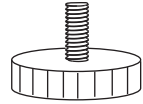

I X1



J X4



M4*14mm

K X4

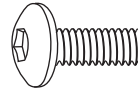

M6*12mm

L X20



M6*25mm

M X8



M6*30mm

3

EN:  : Partially tighten the screws.

 : Fully tighten the screws.

ES:  : Apriete parcialmente los tornillos.

 : Apriete completamente los tornillos.

FR:  : Serrez d'abord les vis partiellement.

 : Serrez les vis complètement.

Step 1

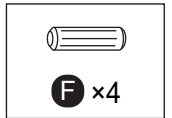
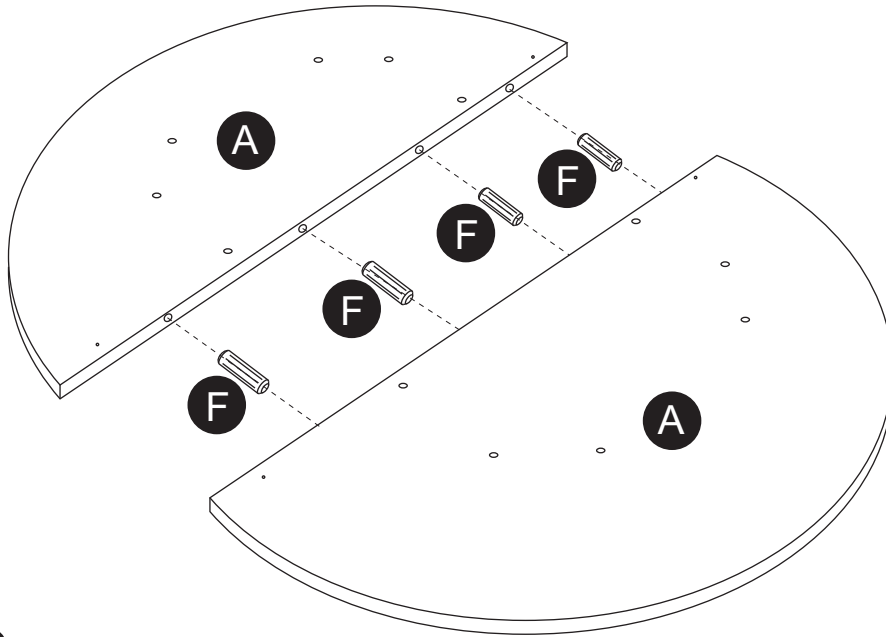

Step 2

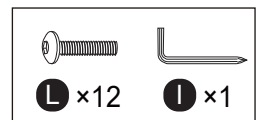
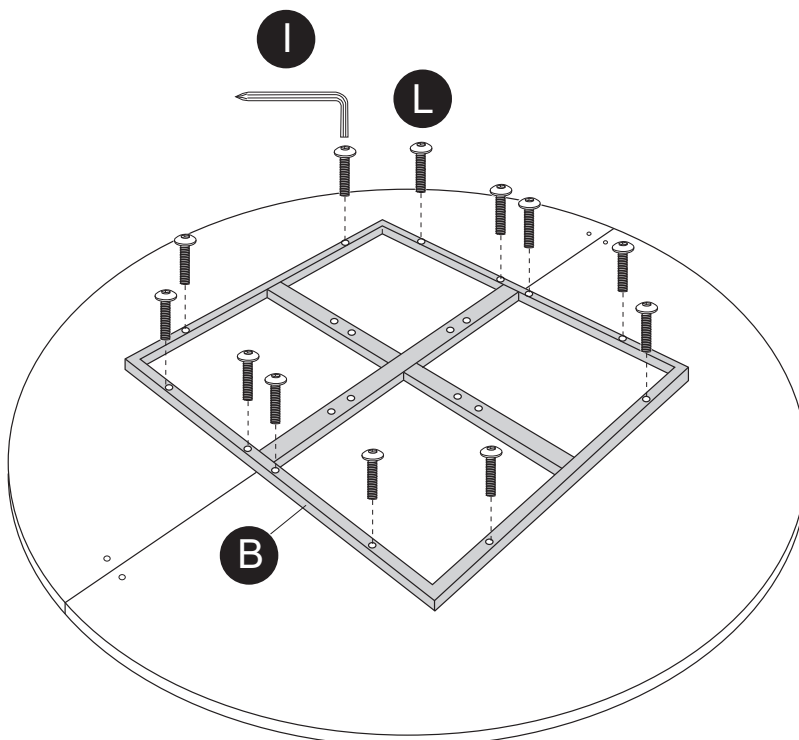
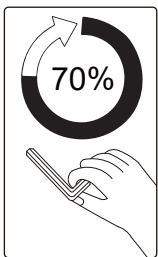

Step 3

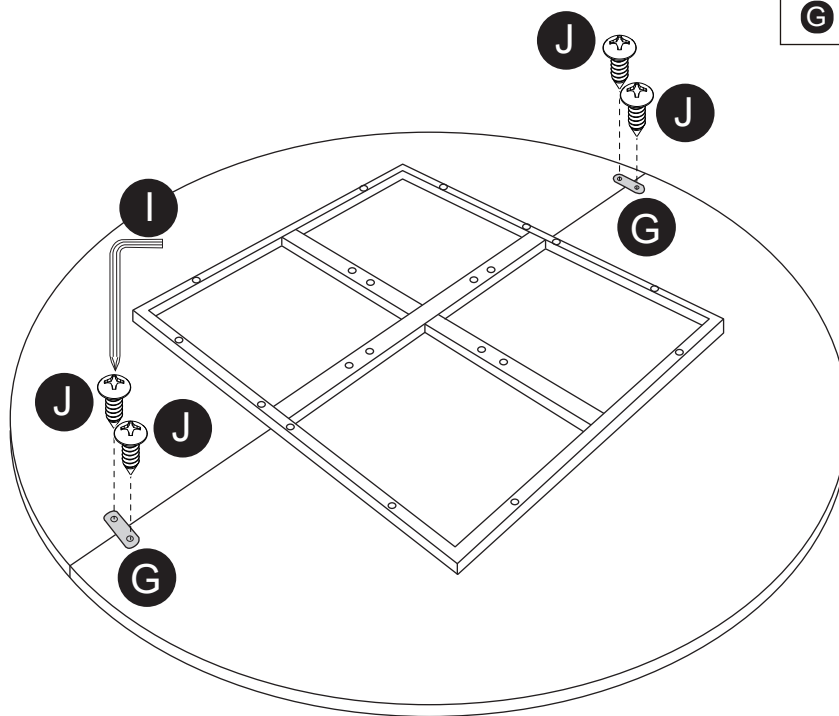
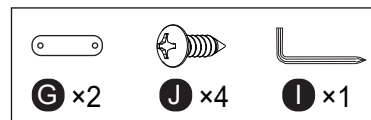
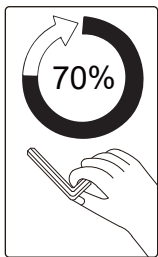

Step 4

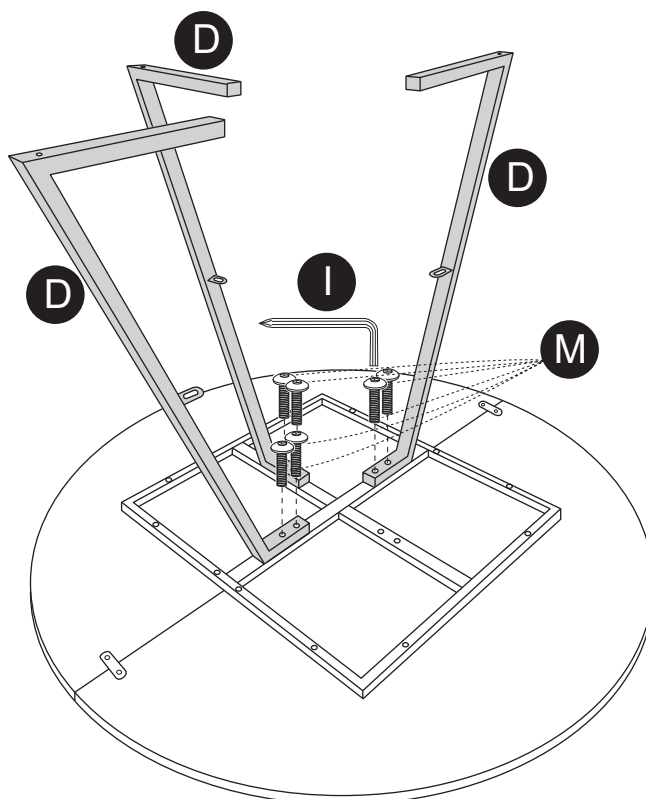
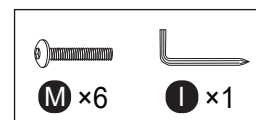
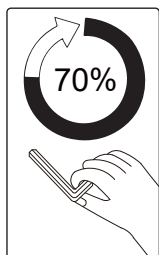

Step 5

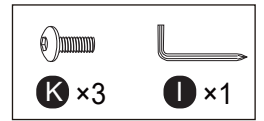
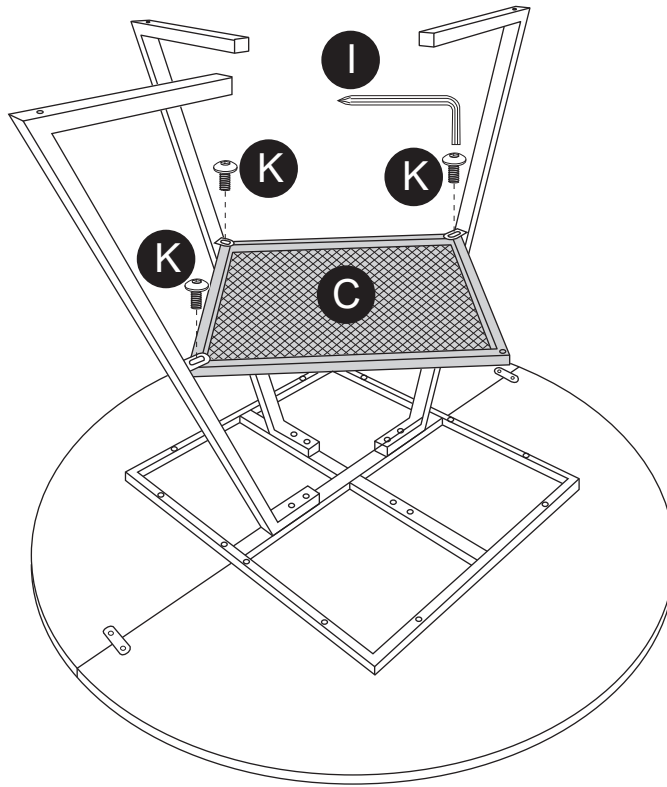
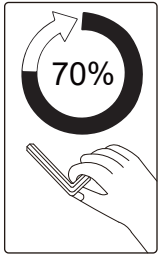

Step 6

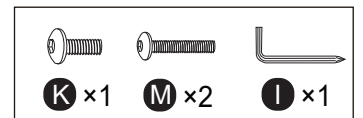
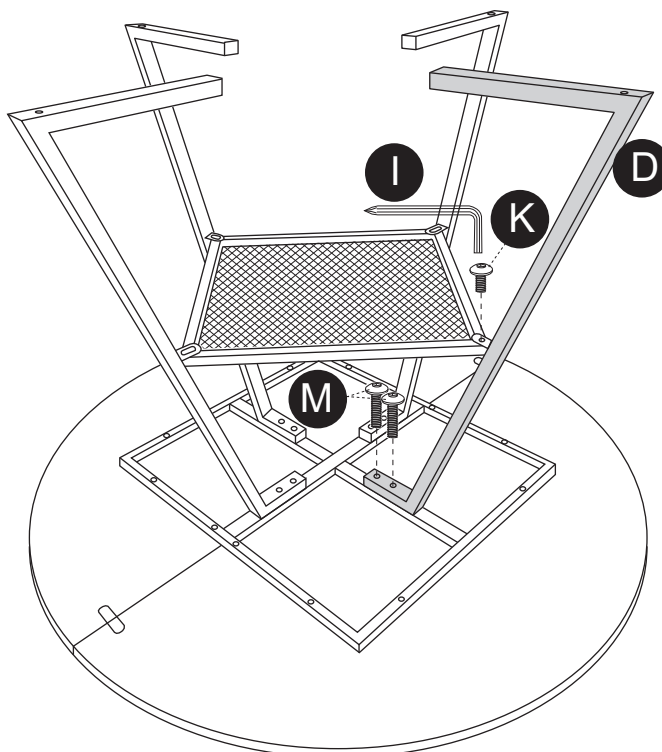
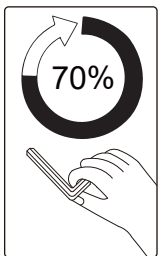

Step 7

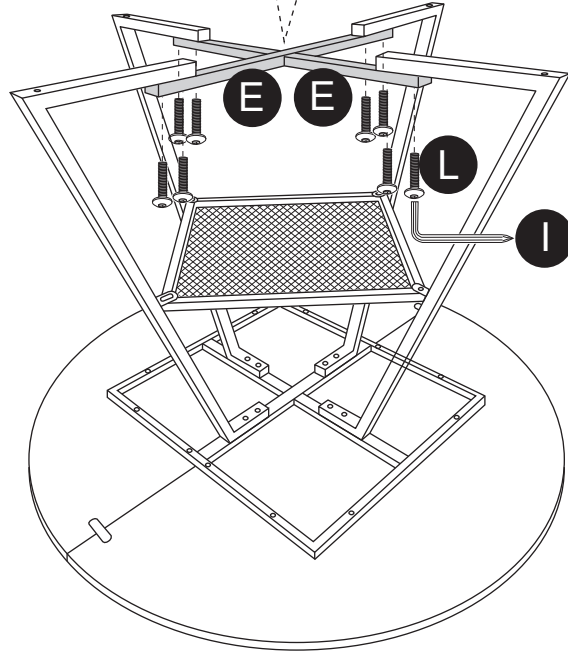
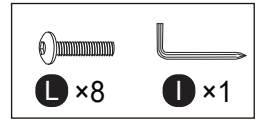
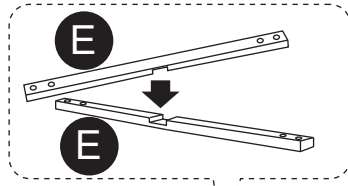
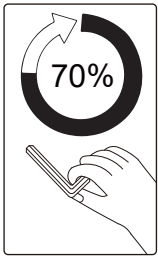

Step 8

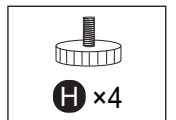
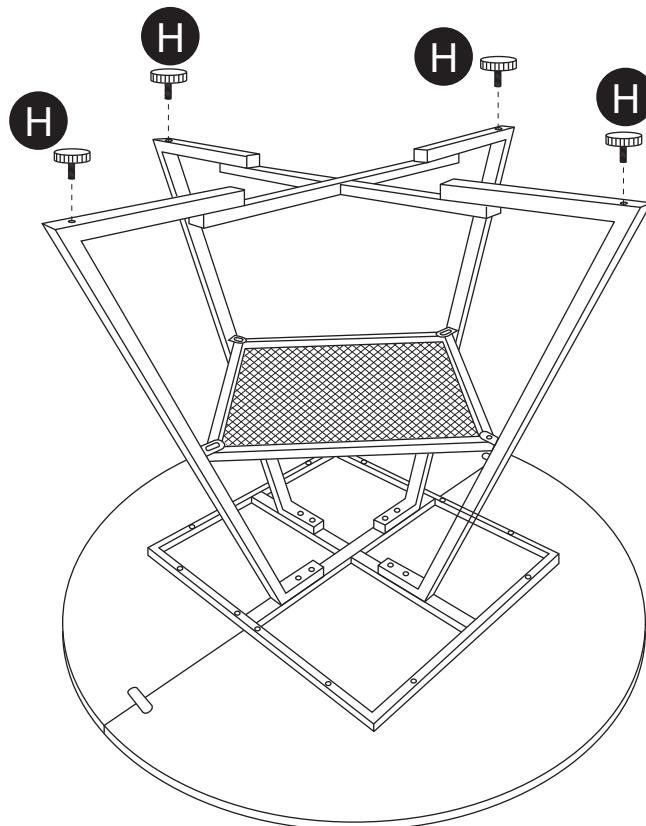

Step 9

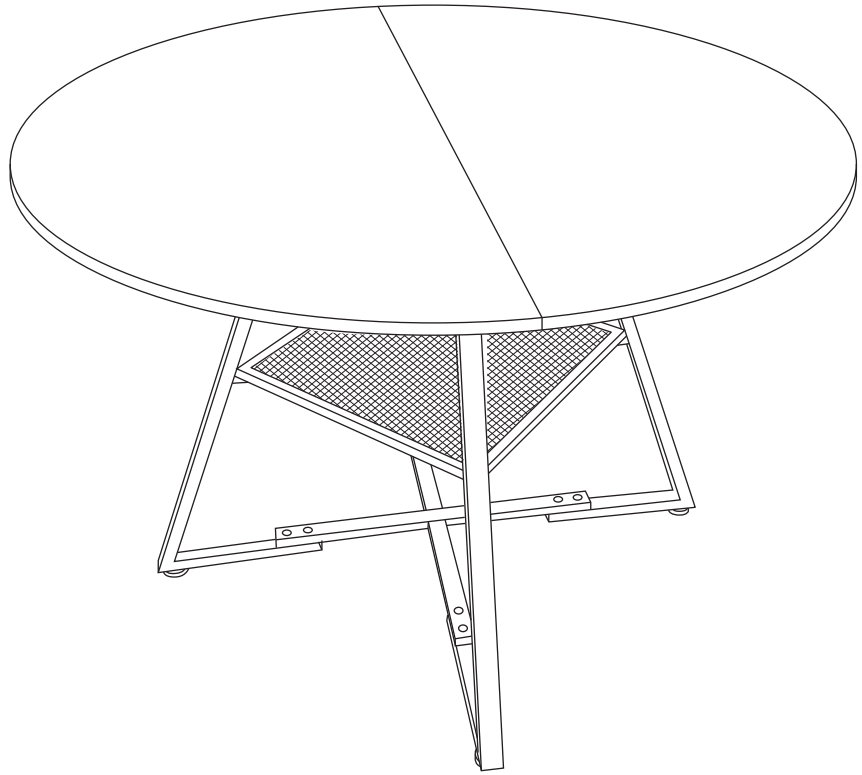
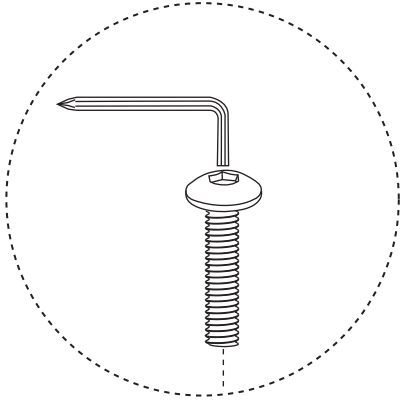
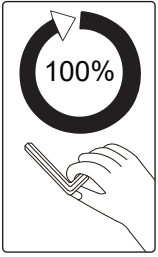

Step 10

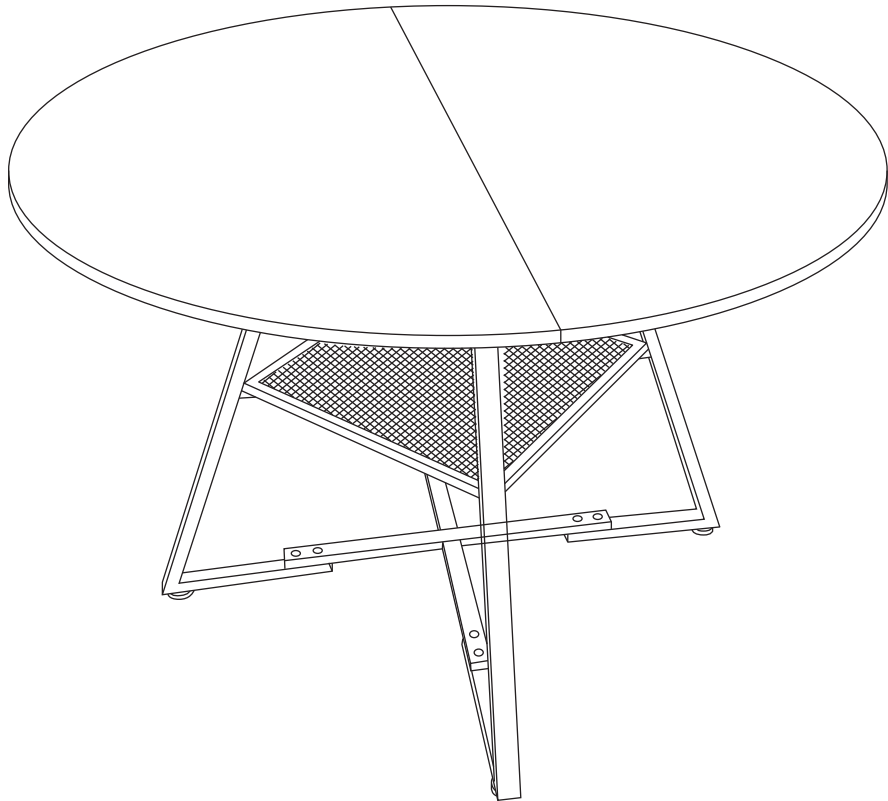

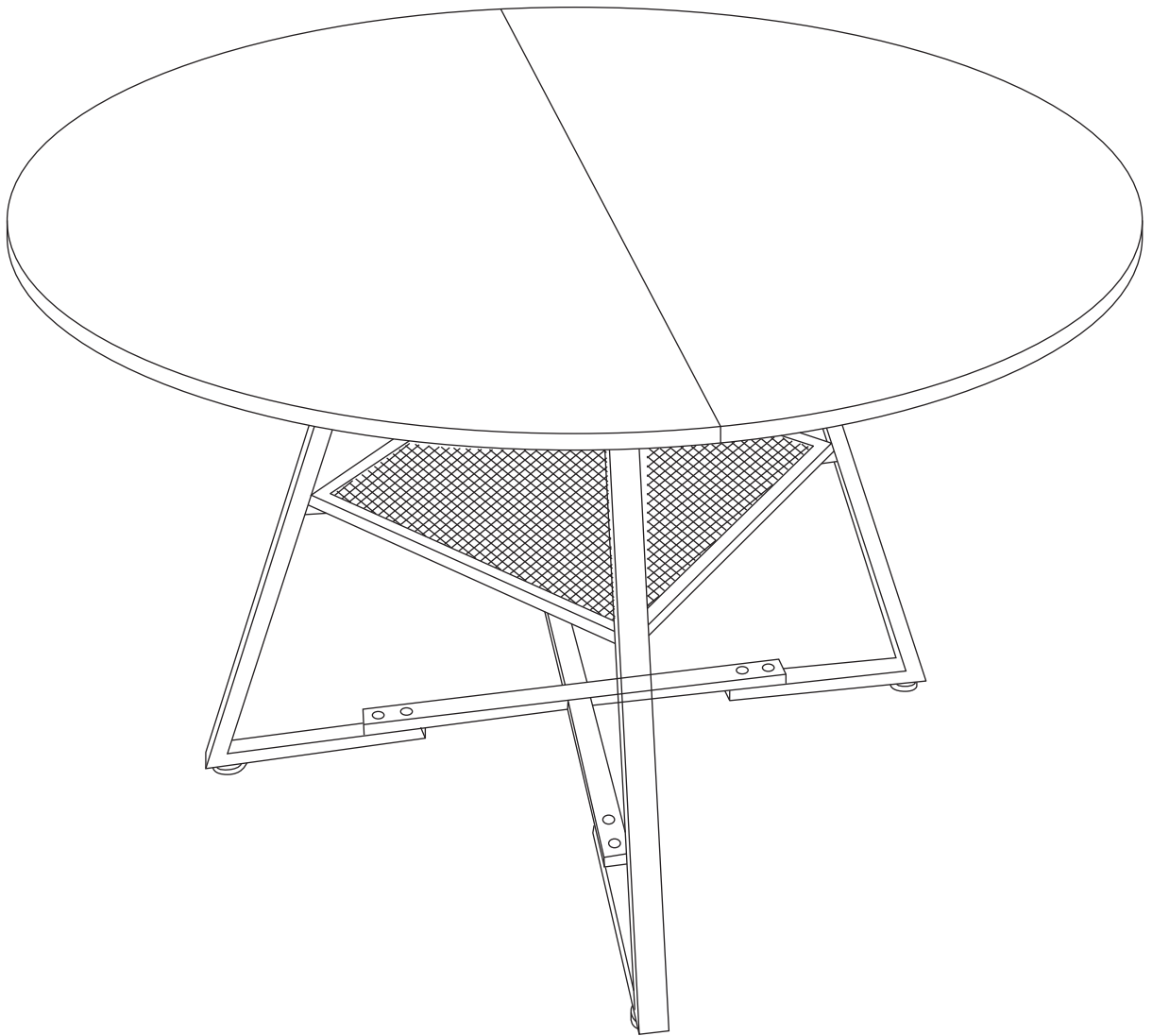

Thank you for choosing this product. We strive to provide you with the best quality products and service in the industry. Should you have any issues, please don't hesitate to contact us.