

Installationsanleitung/Installation Instruction/Instruction d'installation
Istruzioni di installazione/Instrucciones de instalación
Installatie-instructies/Installationsanvisningar/Instrukcje instalacji
BARTISCH-N620P430613/N620P430614
BAR TABLE-N639P430646/N639P430647

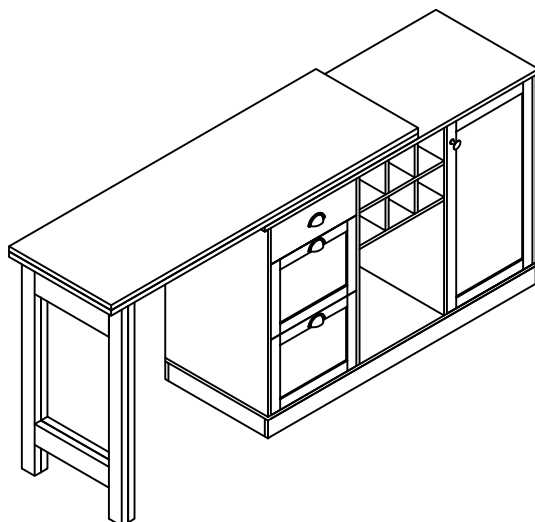

DE: Unser Produkt wird Ihnen in 2 Paketen geliefert. Die Lieferzeiten dieser 2 Pakete können abweichen, bitte haben Sie etwas Geduld und vielen Dank für Ihr Verständnis.

UK: Our product will be delivered to you in 2 packages. The delivery times of these 2 packages may differ, please be patient and thank you for your understanding.

FR: Notre produit vous sera livré en 2 colis. Les délais de livraison de ces 2 colis peuvent différer, soyez patient et merci pour votre compréhension.

IT: Il nostro prodotto verrà consegnato in 2 pacchi. I tempi di consegna di questi 2 pacchi possono variare; vi preghiamo di avere un po' di pazienza e vi ringraziamo per la vostra comprensione.

ES: Nuestro producto se entregará en 2 paquetes. Los tiempos de entrega de estos 2 paquetes pueden variar; por favor, tenga un poco de paciencia y gracias por su comprensión.

Installatie-instructies/Installationsanvisningar/Instrukcje instalacji

NL: Ons product wordt in 2 pakketten bij u geleverd. De levertijden van deze 2 pakketten kunnen verschillen, we vragen om uw geduld en bedanken u voor uw begrip.

SE: Vår produkt kommer att levereras till dig i 2 paket. Leveranstiderna för dessa 2 paket kan variera, vi ber om ditt tålamod och tackar för din förståelse.

PL: Nasz produkt zostanie dostarczony w 2 paczkach. Czas dostawy tych 2 paczek może się różnić, prosimy o cierpliwość i dziękujemy za zrozumienie.

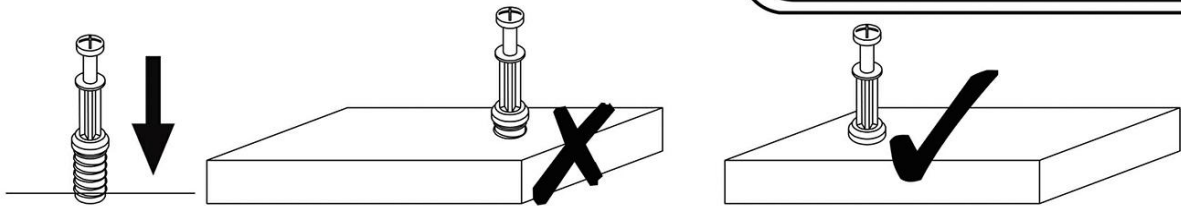

EN_QUICKFIT: Tighten quickfit until shoulder is flush with panel. Do not overtighten or undertighten.

FR_RACCORD RAPIDE: Faites serrer le raccord rapide jusqu'à ce que l'épaulement soit parfaitement encastré dans le panneau. Il ne faut ni trop serrer ni insuffisamment serrer.

ES_QUICKFIT: Apriete quickfit hasta que el hombro se descargue con el panel. NO lo sobreapriete ni lo apriete poco.

DE_QUICKFIT: Ziehen Sie den Quickfit fest, bis die Schulter mit der Platte bündig ist. Bitte nicht zu fest oder zu schwach anziehen.

IT_MONTAGGIO RAPIDO: Stringere il montaggio rapido fino a quando la spalla è a filo con il pannello, non stringere troppo o troppo poco.

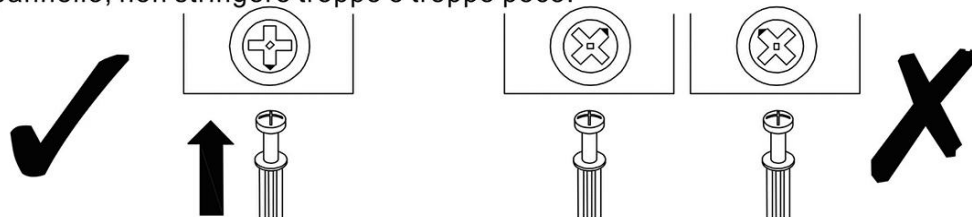

EN_CAM LOCK: When fitting cam lock, ensure starting position is correct before you insert connecting quickfit.

FR_SERRURE BATTEUSE: Avant d'insérer la serrure batteuse, veillez à la bonne orientation avant d'insérer le raccord rapide.

ES_CIERRE DE LA CÁMARA: Cuando instale el cierre de la cámara, asegúrese de que la posición de inicio es correcta antes de que inserte el quickfit conector.

DE_CAM-LOCK: Achten Sie bei der Montage des Cam-Locks auf die richtige Ausgangsposition, bevor Sie den Quickfit einsetzen.

IT_BLOCCAGGIO A CAMMA: Quando si monta il bloccaggio a camma, assicurarsi che la posizione iniziale sia corretta prima di inserire il montaggio rapido di collegamento.

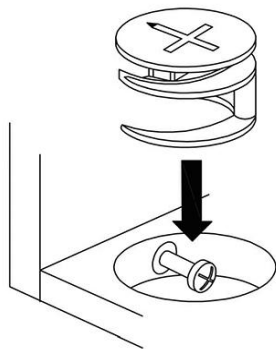

EN_Quickfit head should be in the centre of the cam lock when the two panels are joined.

Cam lock should be inserted before quickfit.

FR_Lorsque les deux panneaux sont assemblés, la tête du raccord rapide doit reposer au centre de la serrure batteuse.

Il faut insérer la serrure batteuse avant le raccord rapide.

ES_El cabezal del quickfit debe estar en el centro del cierre de la cámara cuando se unan los dos paneles.

Se debe insertar el cierre de la cámara antes que el quickfit.

DE_Der Quickfit-Kopf sollte sich in der Mitte des Cam-Locks befinden, wenn die beiden Platten zusammengefügt sind.

Der Cam-Lock sollte vor dem Quickfit eingesetzt werden.

IT_La testa del montaggio rapido deve trovarsi al centro del bloccaggio a camma quando i due pannelli sono uniti.

Il Bloccaggio a Camma deve essere inserito prima del montaggio rapido.

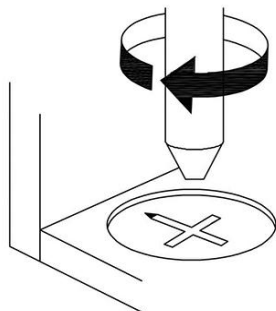

EN_Turn cam lock clockwise to tighten.

FR_Faites tourner la serrure batteuse dans le sens des aiguilles d'une montre pour la resserrer.

ES_Gire el cierre de la cámara en sentido horario para apretarlo.

DE_Drehen Sie den Cam-Lock im Uhrzeigersinn, um ihn festzuziehen.

IT_Ruotare il bloccaggio a camma in senso orario per stringere.

DE

1. Die maximale Tragfähigkeit der Oberplatte beträgt 60 kg, bitte nicht überladen.
2. Lassen Sie Kinder nicht auf Möbeln klettern, da dies zu Umstürzen und schweren Verletzungen führen kann.
3. Um die Sicherheit zu gewährleisten, installieren Sie bitte gemäß der Anleitung und ziehen Sie bei Bedarf Fachleute hinzu.
4. Stellen Sie Möbel nicht in die Nähe von Feuerquellen oder heißen Gegenständen, um Brandgefahr zu vermeiden.
5. Stellen Sie Möbel nicht in feuchten Umgebungen auf, um Materialschäden zu verhindern.
6. Überprüfen Sie regelmäßig alle Verbindungs- und Befestigungselemente, um sicherzustellen, dass sie fest sitzen und Unfälle zu vermeiden.
7. Dieses Produkt ist mit einem Kipp-Schutz ausgestattet, installieren Sie diesen Schutz, um Verletzungen durch Umstürzen zu vermeiden.

UK

1. The maximum weight capacity of the top panel is 60kg; please do not overload.
2. Do not allow children to climb on furniture, as this may cause tipping and serious injury.
3. To ensure safety, please install correctly according to the instructions and seek professional assistance if necessary.
4. Do not place furniture near fire sources or hot objects to avoid fire hazards.
5. Do not place furniture in damp environments to prevent material damage.
6. Regularly check all connectors and fasteners to ensure they are secure to prevent accidents.
7. This product comes with a anti-tipping device; install this device to prevent injuries from tipping.

FR

1. La charge maximale du panneau supérieur est de 60 kg, ne pas surcharger.
2. Ne laissez pas les enfants grimper sur les meubles, cela peut entraîner des basculements et des blessures graves.
3. Pour garantir la sécurité, installez correctement selon les instructions et demandez l'aide de professionnels si nécessaire.
4. Ne placez pas les meubles près de sources de chaleur ou d'objets chauds pour éviter les risques d'incendie.
5. Ne placez pas les meubles dans des environnements humides pour éviter d'endommager les matériaux.
6. Vérifiez régulièrement tous les connecteurs et les fixations pour vous assurer qu'ils sont bien serrés et éviter les accidents.
7. Ce produit est équipé d'un dispositif anti-basculement; installez ce dispositif pour éviter les blessures dues au basculement.

IT

1. La capacità massima del pannello superiore è di 60 kg; non sovraccaricare.
2. Non permettere ai bambini di arrampicarsi sui mobili, poiché ciò può causare ribaltamenti e gravi infortuni.
3. Per garantire la sicurezza, installare correttamente secondo le istruzioni e, se necessario, chiedere assistenza a professionisti.
4. Non posizionare i mobili vicino a fonti di calore o oggetti caldi per evitare rischi di incendio.
5. Non posizionare i mobili in ambienti umidi per prevenire danni ai materiali.
6. Controllare regolarmente tutti i connettori e le viti per assicurarsi che siano saldi e prevenire incidenti.
7. Questo prodotto è dotato di un dispositivo anti-ribaltamento; installare questo dispositivo per evitare infortuni da ribaltamento.

ES

1. La capacidad máxima del panel superior es de 60 kg; no sobrecargar.
2. No permita que los niños escalen los muebles, ya que esto puede causar volcaduras y lesiones graves.
3. Para garantizar la seguridad, instale correctamente según las instrucciones y busque ayuda profesional si es necesario.
4. No coloque los muebles cerca de fuentes de fuego u objetos calientes para evitar riesgos de incendio.
5. No coloque los muebles en ambientes húmedos para evitar daños en los materiales.
6. Revise regularmente todos los conectores y sujetadores para asegurarse de que estén seguros y prevenir accidentes.
7. Este producto viene con un dispositivo anti-vuelco; instale este dispositivo para prevenir lesiones por vuelcos.

NL

1. De maximale draagcapaciteit van het bovenpaneel is 60 kg; niet overbelasten.
2. Laat kinderen niet op meubels klimmen, dit kan leiden tot omvallen en ernstige verwondingen.
3. Installeer correct volgens de instructies om de veiligheid te waarborgen, en schakel indien nodig professionele hulp in.
4. Plaats meubels niet in de buurt van vuurbronnen of warme objecten om brandgevaar te voorkomen.
5. Plaats meubels niet in vochtige omgevingen om materiaalschade te voorkomen.
6. Controleer regelmatig alle verbindingen en bevestigingsmiddelen om ervoor te zorgen dat ze stevig zijn en om ongevallen te voorkomen.
7. Dit product is uitgerust met een kantelbeveiliging; installeer dit apparaat om verwondingen door omvallen te voorkomen.

SE

1. Den maximala vikt kapaciteten för överpanelen är 60 kg; överbelasta inte.
2. Låt inte barn klättra på möbler, då detta kan orsaka tippning och allvarliga skador.
3. För att säkerställa säkerheten, installera korrekt enligt instruktionerna och sök professionell hjälp om det behövs.
4. Placera inte möbler nära eldkällor eller heta föremål för att undvika brandrisk.
5. Placera inte möbler i fuktiga miljöer för att förhindra skador på materialen.
6. Kontrollera regelbundet alla kopplingar och fästelement för att säkerställa att de är säkra för att förhindra olyckor.
7. Denna produkt levereras med en anti-tippanordning; installera denna anordning för att förhindra skador vid tippning.

PL

1. Maksymalne obciążenie górnej płyty wynosi 60 kg; nie przeciążaj.
2. Nie pozwól dzieciom wspinać się na meble, ponieważ może to prowadzić do przewrócenia się i poważnych obrażeń.
3. Aby zapewnić bezpieczeństwo, zainstaluj prawidłowo zgodnie z instrukcją i w razie potrzeby skorzystaj z pomocy profesjonalistów.
4. Nie stawiaj mebli w pobliżu źródeł ognia lub gorących przedmiotów, aby uniknąć ryzyka pożaru.
5. Nie stawiaj mebli w wilgotnych środowiskach, aby zapobiec uszkodzeniu materiałów.
6. Regularnie sprawdzaj wszystkie złącza i elementy mocujące, aby upewnić się, że są stabilne i aby zapobiec wypadkom.
7. Produkt ten jest wyposażony w urządzenie zapobiegające przewróceniu; zainstaluj to urządzenie, aby uniknąć obrażeń w wyniku przewrócenia.

-Components - fittings

Please check you have all the panels listed below.

Note: The quantitie below are the correcet amount to complete the assembly. In some cases more fittings

may be supplied than are required.

-Komponenten Verschraubungen

Bitte überprüfen Sie, ob Sie alle unten aufgeführten Panels haben.

Hinweis: Die folgende Menge ist die richtige Menge, um die Montage abzuschließen. In einigen Fällen

können mehr Armaturen geliefert werden, als erforderlich.

-Composants - accessoires



Veuillez vérifier que vous possédez tous les panneaux énumérés ci - dessous.

Remarque: les quantités ci - dessous sont les quantités correspondantes nécessaires pour terminer

l'assemblage. Dans certains cas, plus d'accessoires que nécessaire peuvent être fournis.

N620P430613- Box:1/2

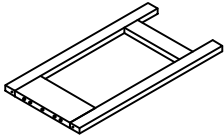
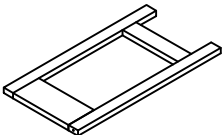
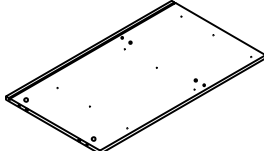
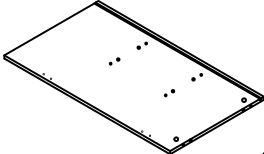
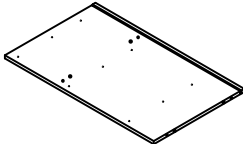
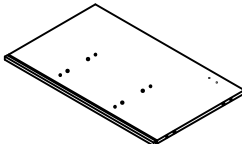

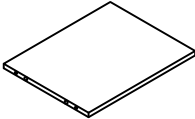
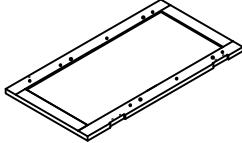
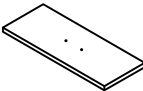
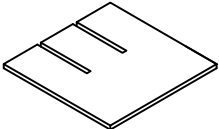
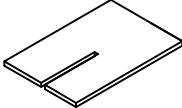
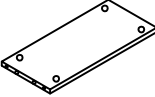
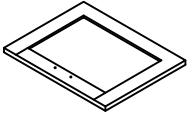
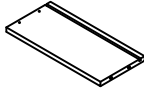
N639P430646- Box:1/2

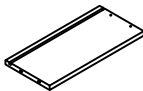
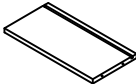
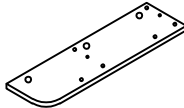
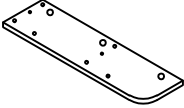
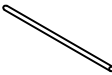
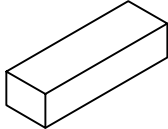
 ③X1	 ④X1	 ⑥X1
 ⑦X1	 ⑧X1	 ⑨X1
 ⑩X2	 ⑪X1	 ⑫X1
 ⑱X1	 ⑳X1	 ㉔X2
 ㉕X2	 ㉖X2	 ㉗X2

 ②⑧X2	 ②⑨X2	 ③⑩X1
 ③①X1	 ③②X2	 HARDWARE

N620P430614- Box:2/2

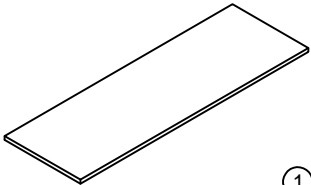
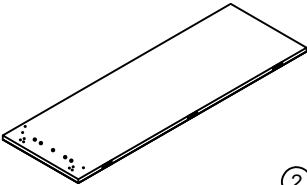
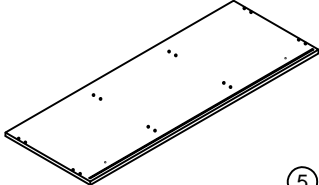
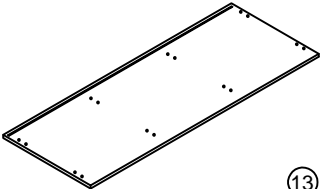
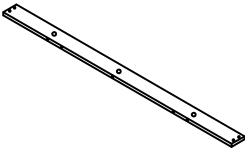
N639P430647- Box:2/2

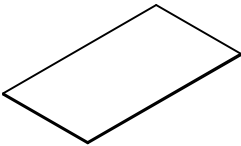
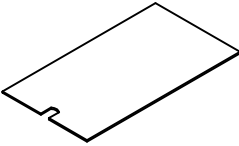
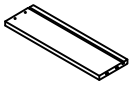
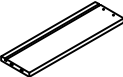
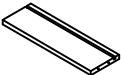
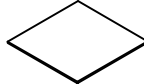
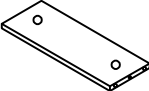
 ①X1	 ②X1	 ⑤X1
 ⑬X1	 ⑭X2	 ⑮X2
 ⑯X1	 ⑰X2	 ⑲X1
 ⑳X1	 ㉑X1	 ㉒X3
 ③③X2		

-Components - fittings

Please check you have all the panels listed below.

Note: The quantitie below are the correcet amount to complete the assembly. In some cases more fittings may be supplied than are required.

-Komponenten Verschraubungen

Bitte überprüfen Sie, ob Sie alle unten aufgeführten Panels haben.

Hinweis: Die folgende Menge ist die richtige Menge, um die Montage abzuschließen. In einigen Fällen können mehr Armaturen geliefert werden, als erforderlich.

-Composants - accessoires











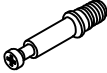









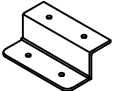

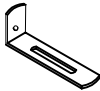

Veuillez vérifier que vous possédez tous les panneaux énumérés ci - dessous.

Remarque: les quantités ci - dessous sont les quantités correspondantes nécessaires pour terminer

l'assemblage. Dans certains cas, plus d'accessoires que nécessaire peuvent être fournis.

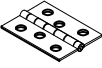
N620P430613- Box:1

N639P430646- Box:1

				
6*35mm	15*10mm	6*30mm	300mm	3*12mm
Ax62PCS	Bx62PCS	Cx56PCS	Dx3PCS	Ex45PCS
				
Fx1PC	Gx1PC	Hx1PC	Ix3PCS	Jx6PCS
				
4*35mm	Lx2PCS	3*14mm	Nx2PCS	4*40mm
Kx12PCS	Lx2PCS	Mx36PCS	Nx2PCS	Ox10PCS
				
3*25mm	4*12mm	Rx3PCS	Sx2PCS	Tx3PCS
Px12PCS	Qx2PCS	Rx3PCS	Sx2PCS	Tx3PCS
				
Ux1PC	Vx2PCS	Wx2PCS	Xx2PCS	Yx12PCS
				
Zx1PC				

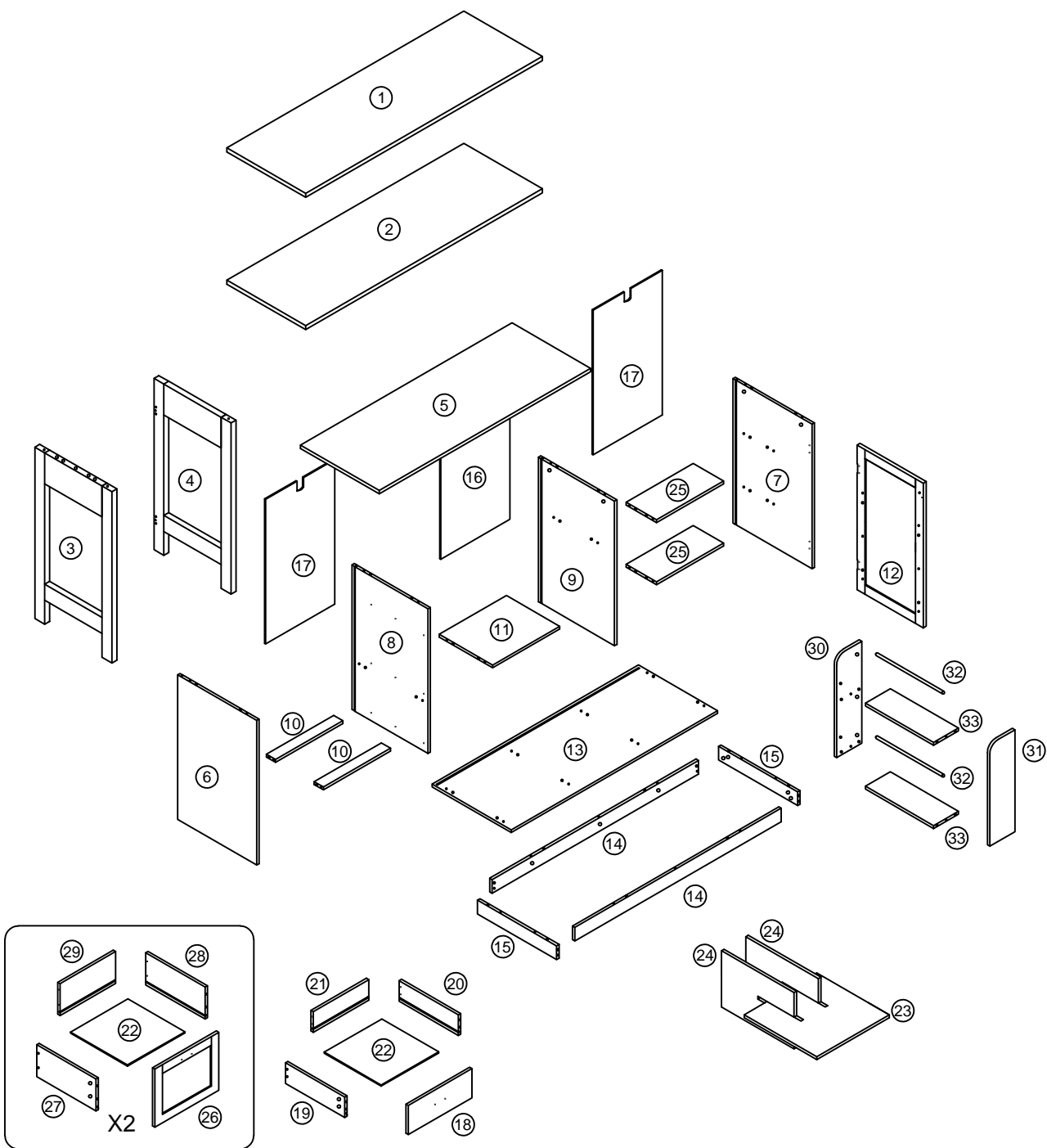



Importeur	Decobus Handel GmbH		
Adresse	Innungsstraße 9, 21244 Buchholz, Deutschland		
URL	https://www.decobusgroup.de		
Hersteller	Ningde Yibang Furniture Co., Ltd		
Adresse	No. 1, Industrial Zone, Gantang Village, Gantang Township, Pingnan County, Ningde City, Fujian, China.		
Email/URL	yvonne@yibang-fur.com		
Partienummer	N620P430613/N620P430614		
Hergestellt in	CHINA		
<table border="1" style="display: inline-table; vertical-align: middle;"> <tr> <td>EC</td> <td>REP</td> </tr> </table>	EC	REP	Decobus Handel GmbH Innungsstraße 9, 21244 Buchholz, Deutschland https://www.decobusgroup.de
EC	REP		

Importer	COMHARBOR LIMITED		
Add	Unit C, Swift Point, Cosford Lane, Rugby, CV21 1PY, GB		
Email/URL	harborcomhar@gmail.com		
Manufacturer	Ningde Yibang Furniture Co., Ltd		
Add	No. 1, Industrial Zone, Gantang Village, Gantang Township, Pingnan County, Ningde City, Fujian, China.		
Email/URL	yvonne@yibang-fur.com		
Product identification	N639P430646/N639P430647		
Made in	CHINA		
<table border="1" style="display: inline-table; vertical-align: middle;"> <tr> <td>UK</td> <td>REP</td> </tr> </table>	UK	REP	COMHARBOR LIMITED Unit C, Swift Point, Cosford Lane, Rugby, CV21 1PY, GB harborcomhar@gmail.com
UK	REP		

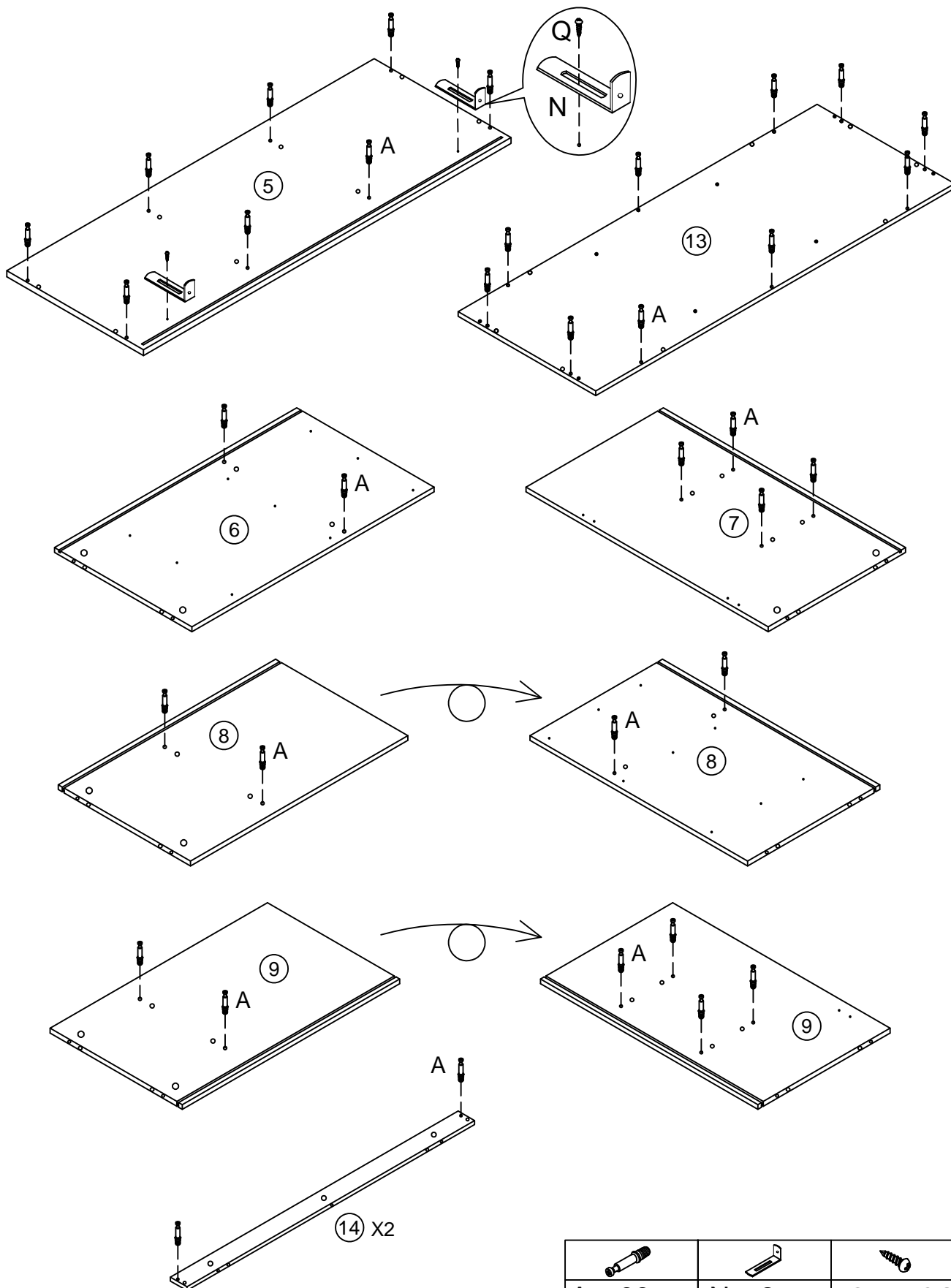
STEP 1/SCHRITT 1/Étapes 1/Passo 1/Paso 1





		
A x 38pcs	N x 2pcs	Qx2PCS

STEP 2/SCHRITT 2/Étapes 2/Passo 2/Paso 2

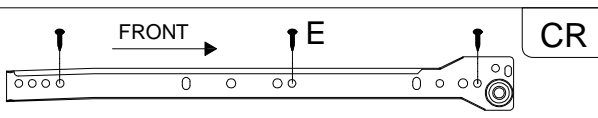
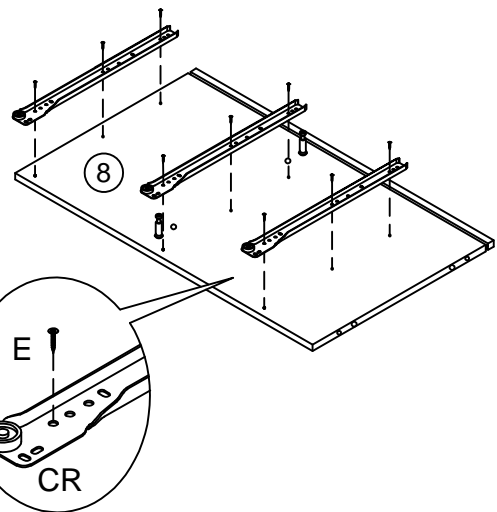
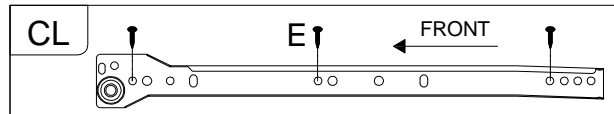
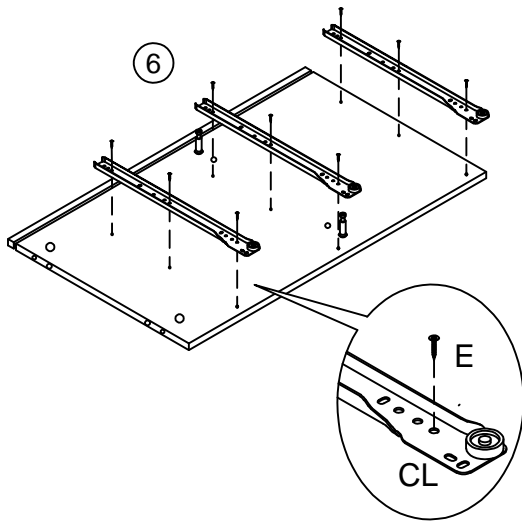
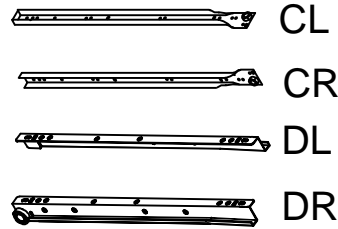
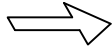

D



		
E x 18pcs	CL x 3pcs	CR x 3pcs

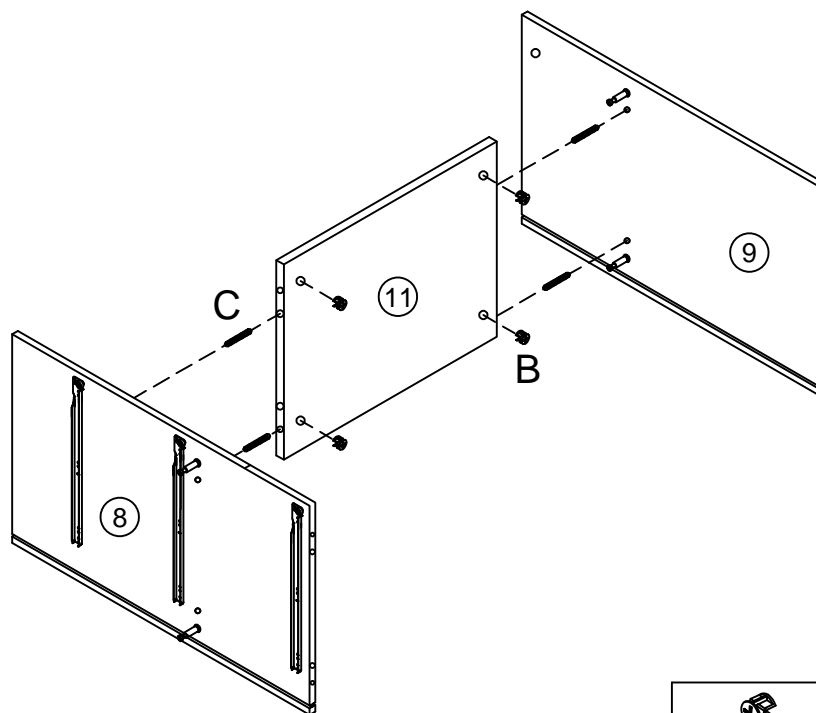

STEP 3/SCHRITT 3/Étapes 3/Passo 3/Paso 3



	
B x 4pcs	C x 4pcs

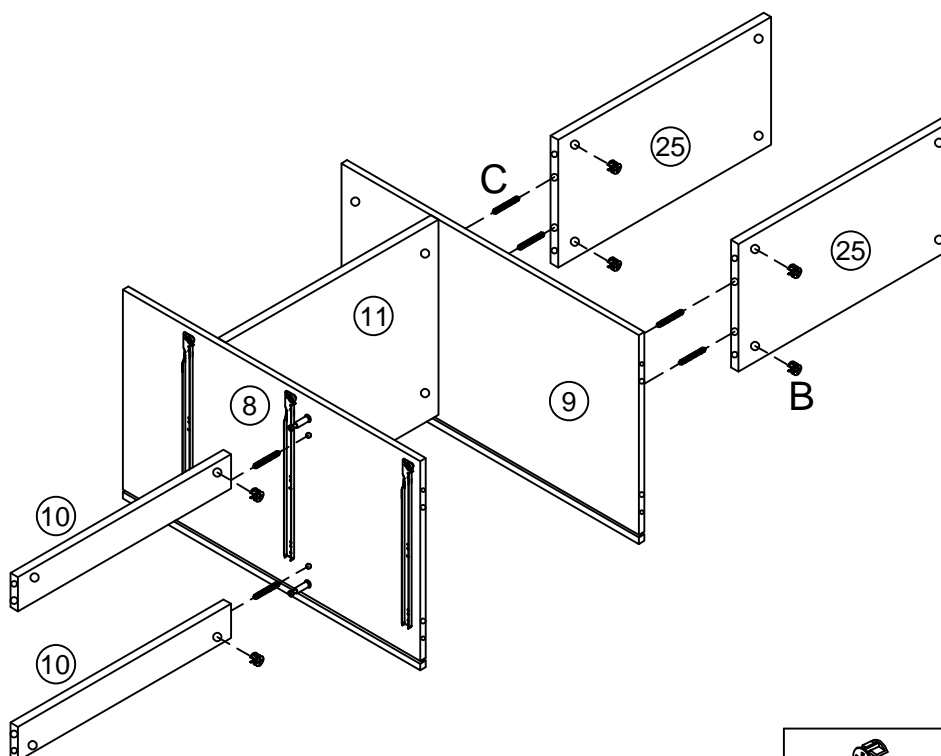

STEP 4/SCHRITT 4/Étapes 4/Passo 4/Paso 4



	
B x 6pcs	C x 6pcs

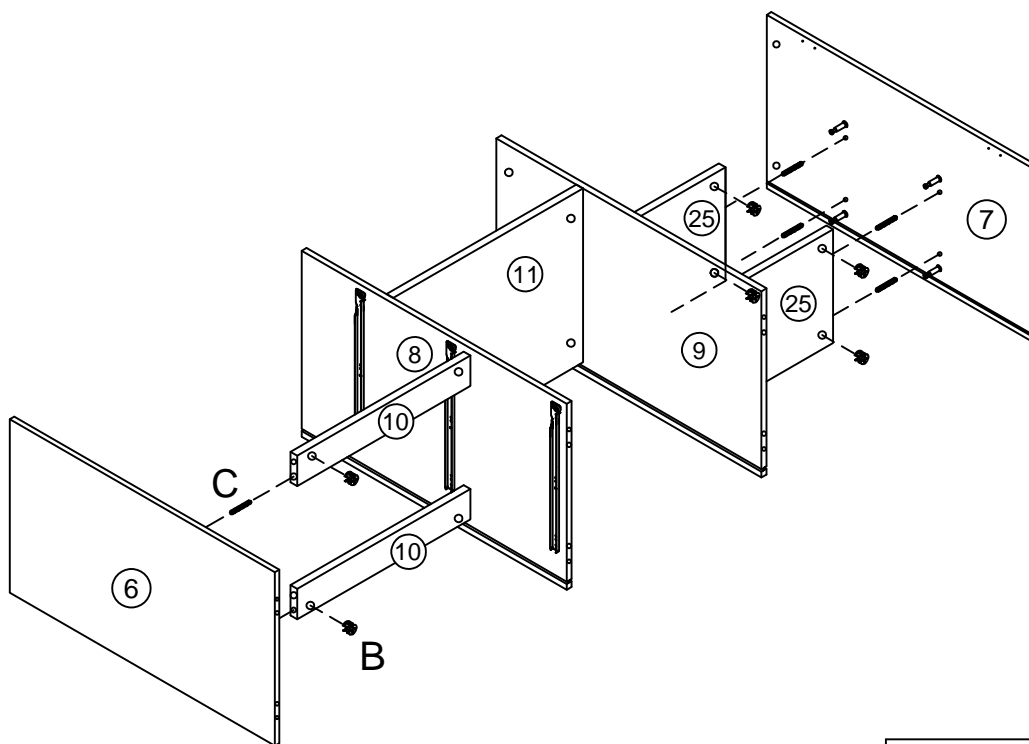

STEP 5/SCHRITT 5/Étapes 5/Passo 5/Paso 5



	
B x 6pcs	C x 6pcs

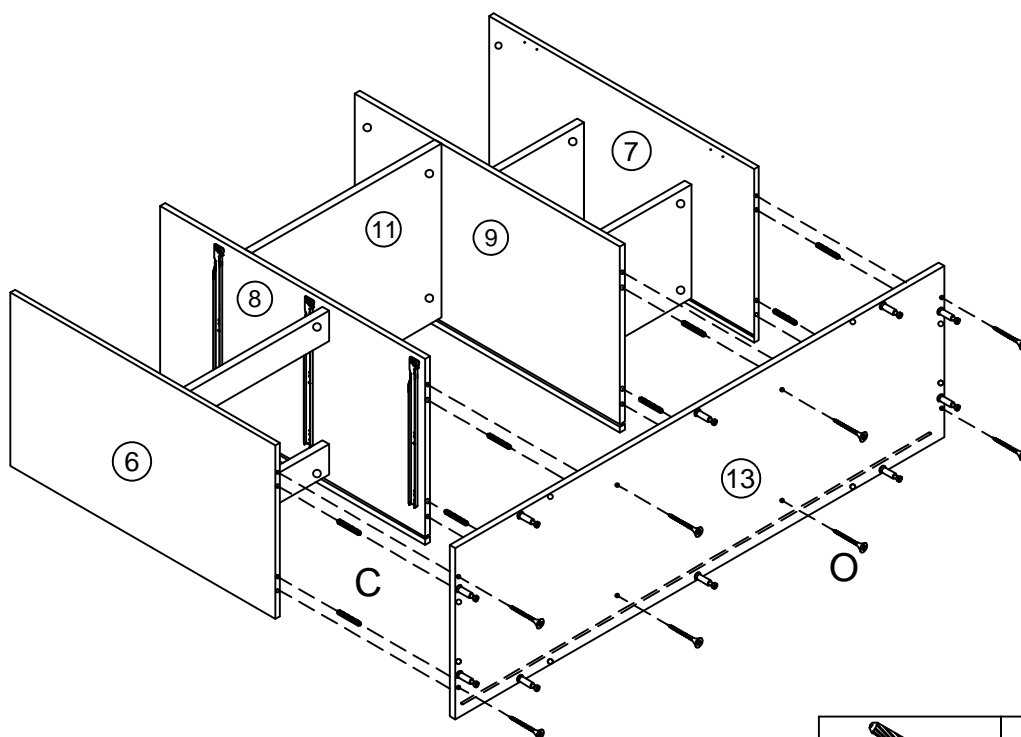

STEP 6/SCHRITT 6/Étapes 6/Passo 6/Paso 6

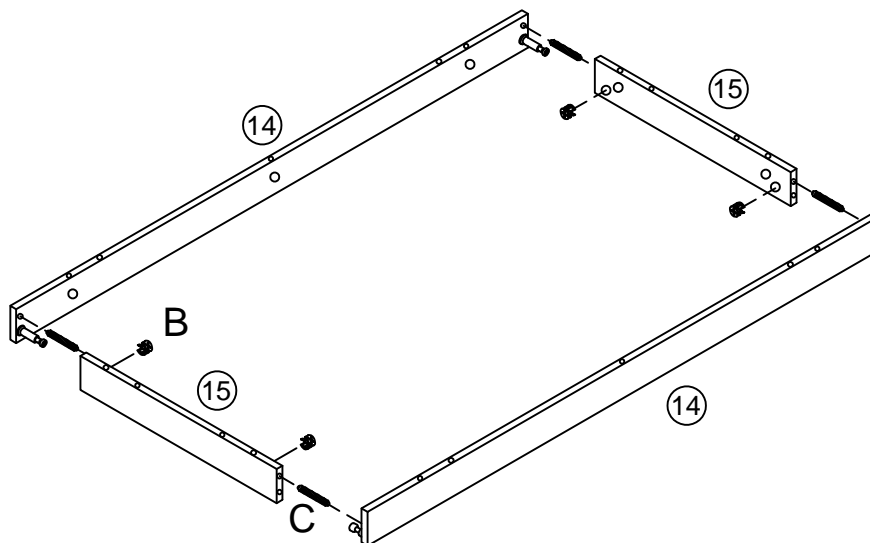

	
C x 8pcs	Ox8PC

STEP 7/SCHRITT 7/Étapes 7/Passo 7/Paso 7



	
B x 4pcs	C x 4pcs

STEP 8/SCHRITT 8/Étapes 8/Passo 8/Paso 8

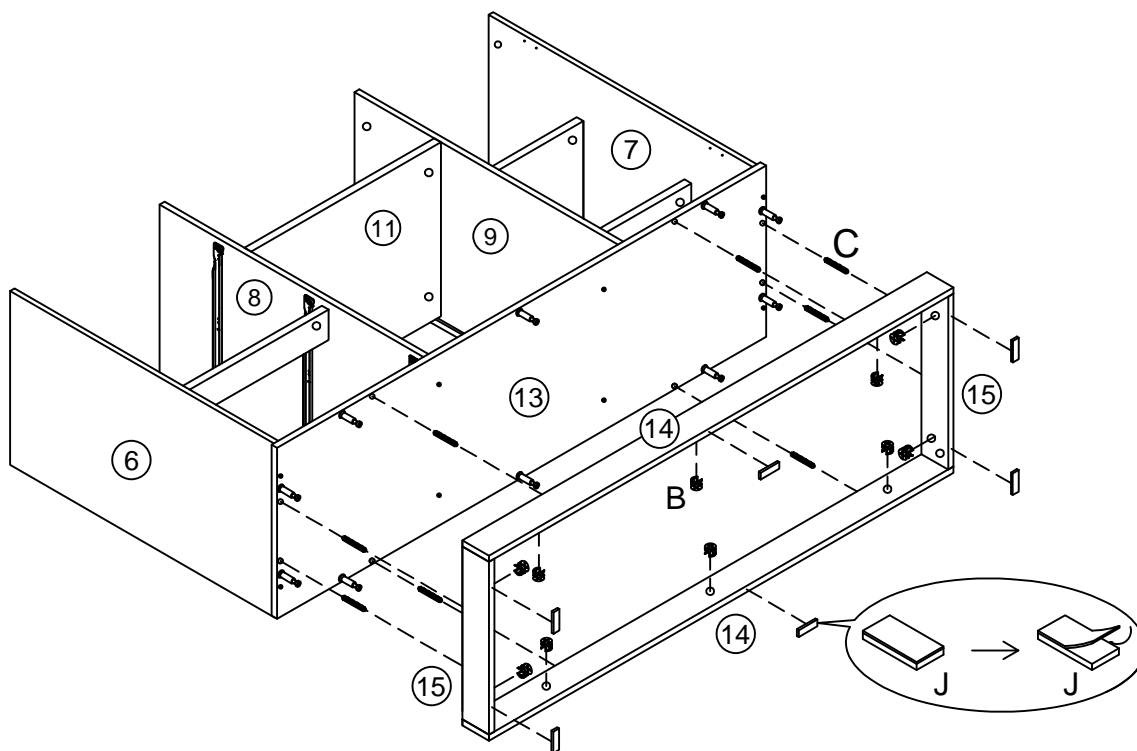

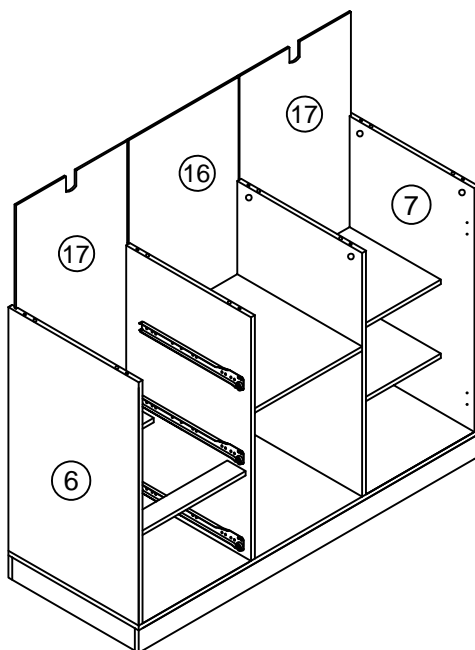

		
B x 10pcs	C x 8pcs	J x 6pcs

STEP 9/SCHRITT 9/Étapes 9/Passo 9/Paso 9



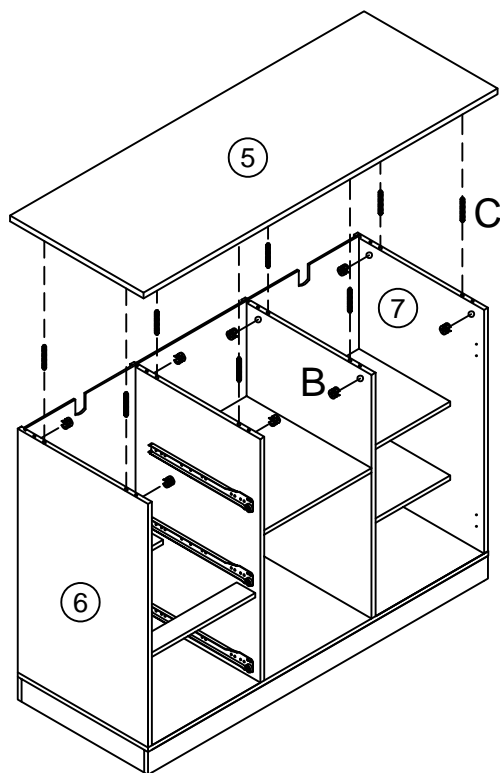

STEP 10/SCHRITT 10/Étapes 10/Passo 10/Paso 10



	
B x 8pcs	C x 8pcs

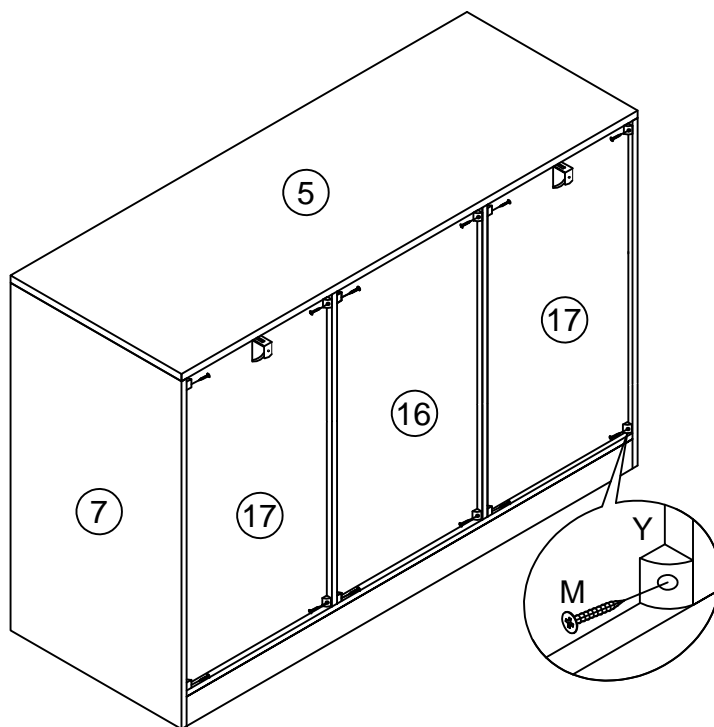

STEP 11/SCHRITT 11/Étapes 11/Passo 11/Paso 11

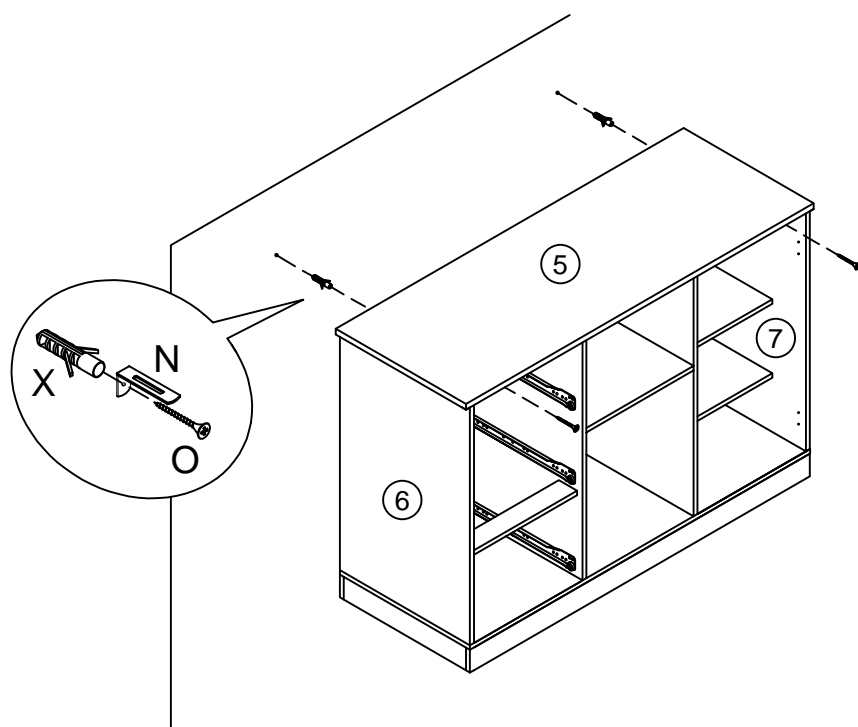

	
Y x 12pcs	M x 12pcs

STEP 12/SCHRITT 12/Étapes 12/Passo 12 Paso 12



	
Ox2PCS	X x 2pcs

STEP 13/SCHRITT 13/
 Étapes 13/Passo 13/Paso 13

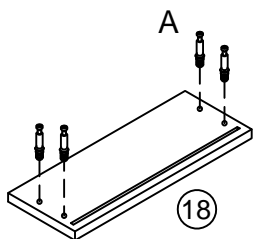

STEP 14/SCHRITT 14/
 Étapes 14/Passo 14/Paso 14

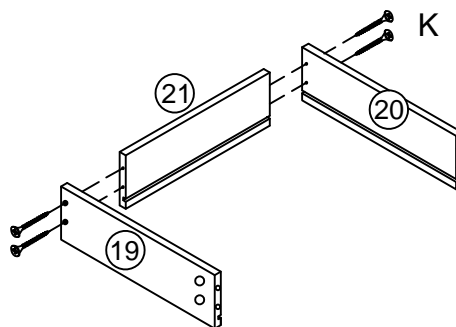

STEP 15/SCHRITT 15/
 Étapes 15/Passo 15/Paso 15

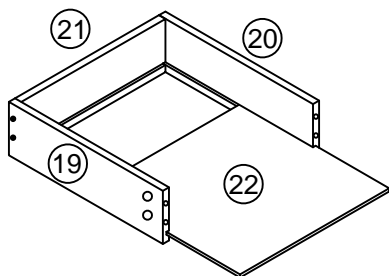

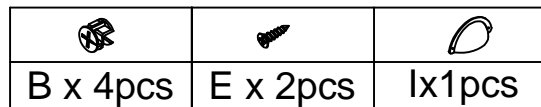
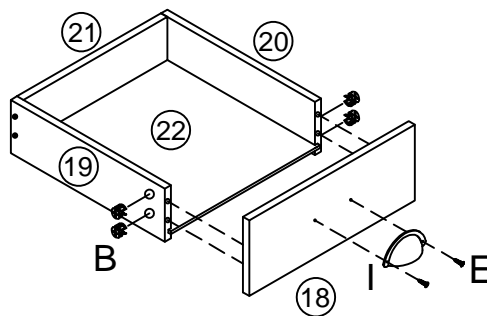

STEP 16/SCHRITT 16/
 Étapes 16/Passo 16/Paso 16

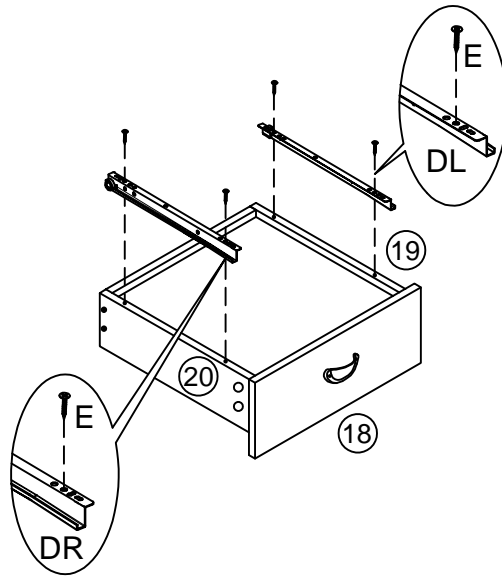
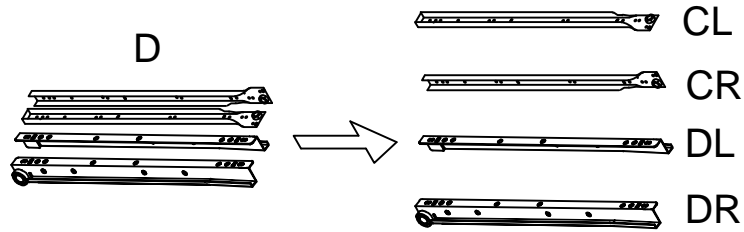

STEP 17/SCHRITT 17/Étapes 17/Passo 17/Paso 17



		
E x 4pcs	DL x 1pcs	DR x 1pcs

STEP 18/SCHRITT 18/
Étapes 18/Passo 18/Paso 18

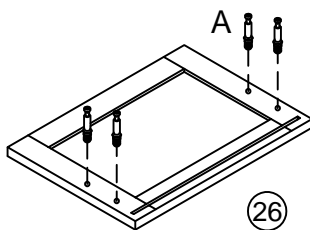

X2

A x 8pcs

STEP 19/SCHRITT 19/
Étapes 19/Passo 19/Paso 19

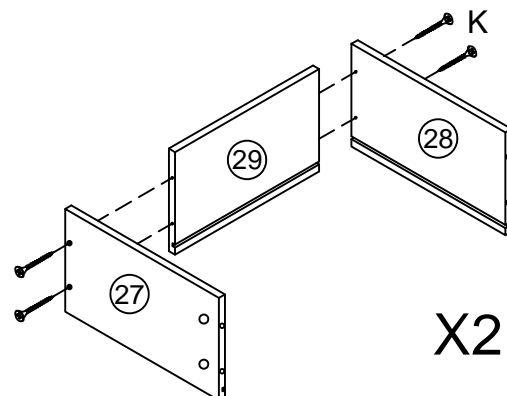

X2



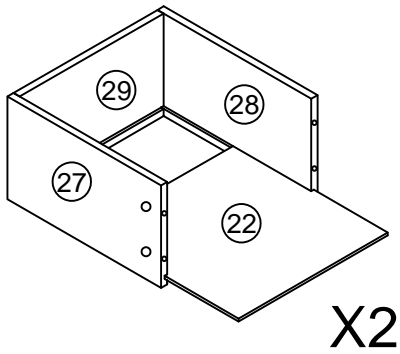

K x 8pcs

STEP 20/SCHRITT 20/
 Étapes 20/Passo 20/Paso 20

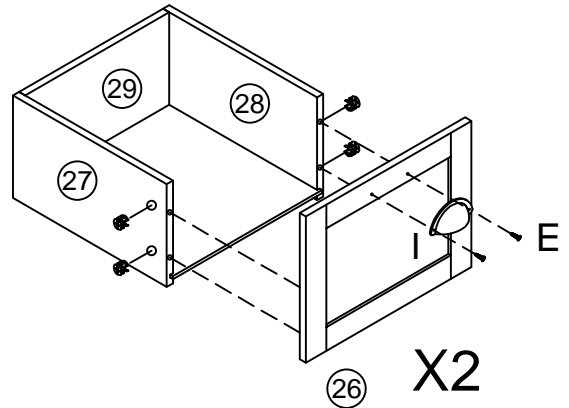





STEP 21/SCHRITT 21/
 Étapes 21/Passo 21/Paso 21

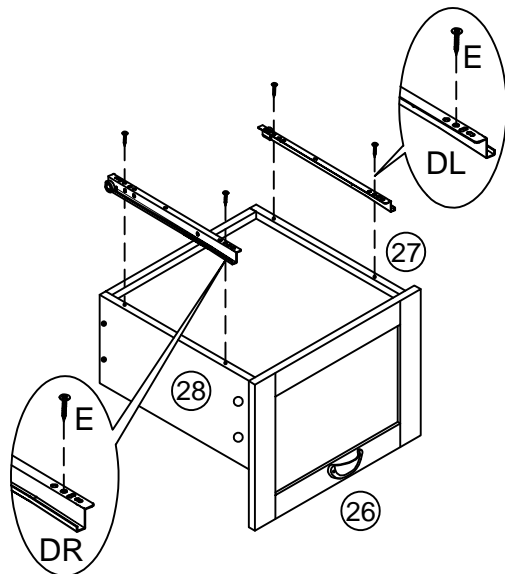
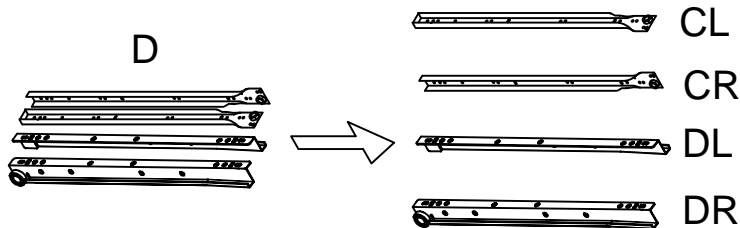

		
B x 8pcs	E x 4pcs	1x2PCS

STEP 22/SCHRITT 22/Étapes 22/Passo 22/Paso 22



		
E x 8pcs	DL x 2pcs	DR x 2pcs

STEP 23/SCHRITT 23/Étapes 23/Passo 23/Paso 23

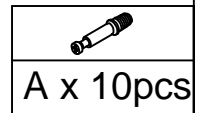
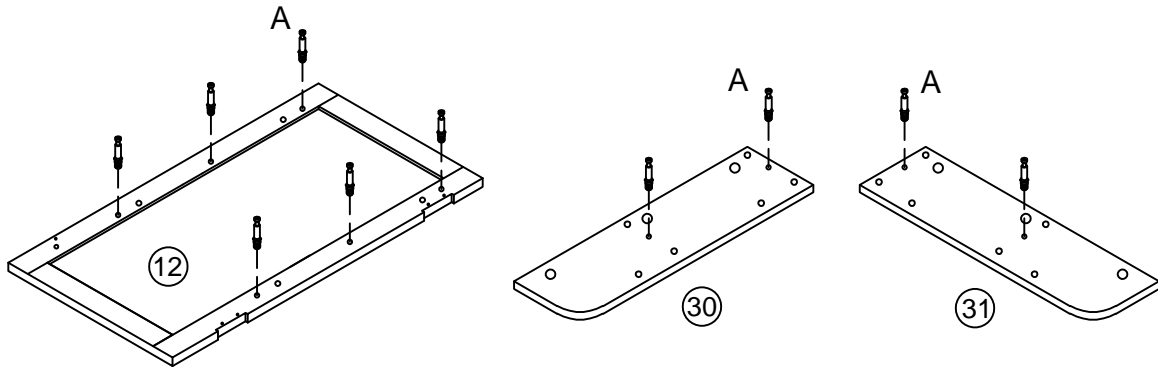

STEP 24/SCHRITT 24/
 Étapes 24/Passo 24/Paso 24

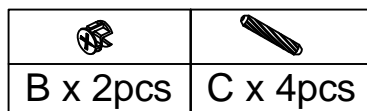
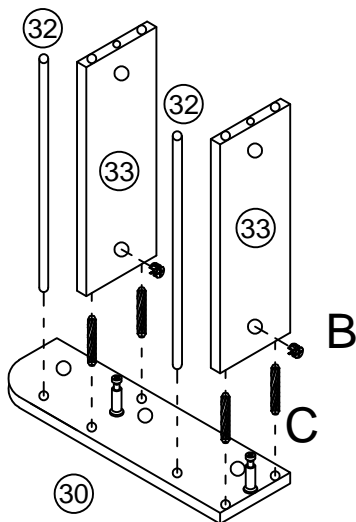

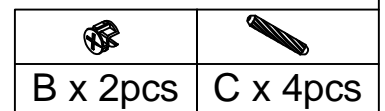
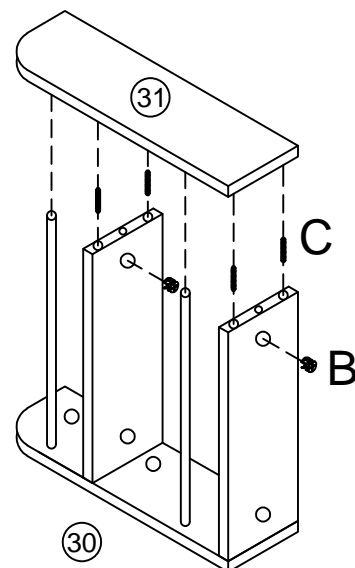

STEP 25/SCHRITT 25/
 Étapes 25/Passo 25/Paso 25



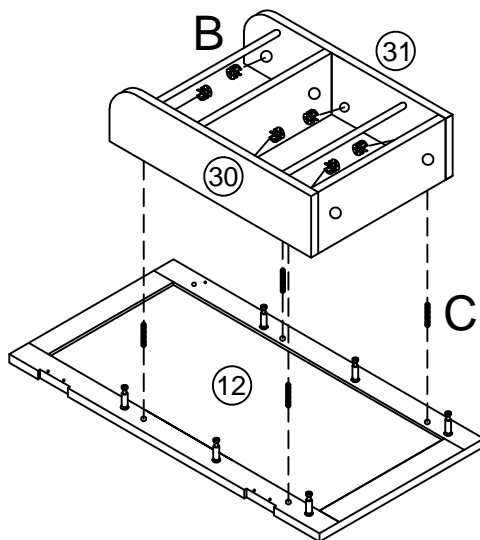



STEP 26/SCHRITT 26/Étapes 26/Passo 26/Paso 26

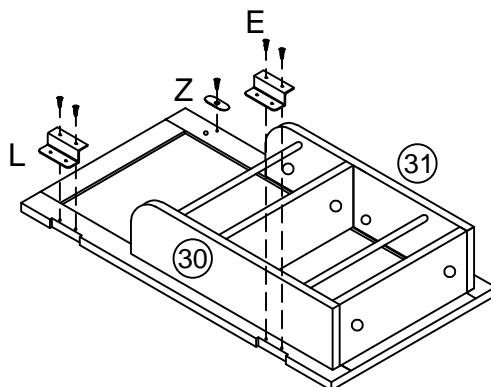

	
B x 6pcs	C x 4pcs





STEP 27/SCHRITT 27/Étapes 27/Passo 27/Paso 27

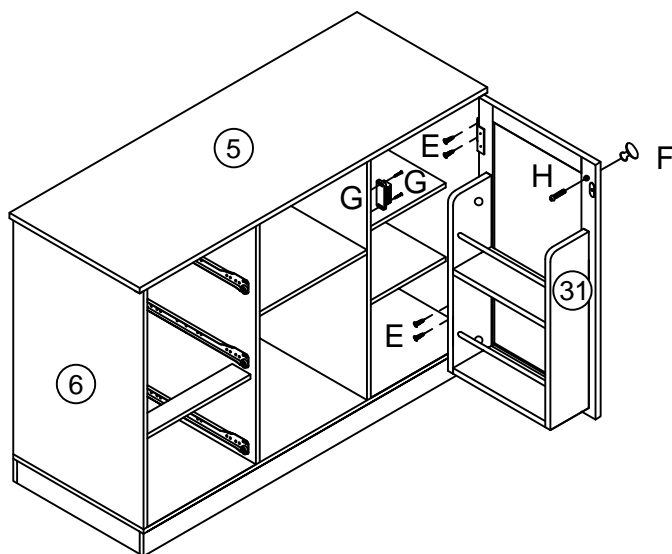

		
E x 5pcs	Z x 1pc	L x 2pcs

STEP 28/SCHRITT 28/Étapes 28/Passo 28/Paso 28



			
E x 4pcs	Gx 1pc	F x 1pc	H x 1pc

STEP 29/SCHRITT 29/Étapes 29/Passo 29/Paso 29

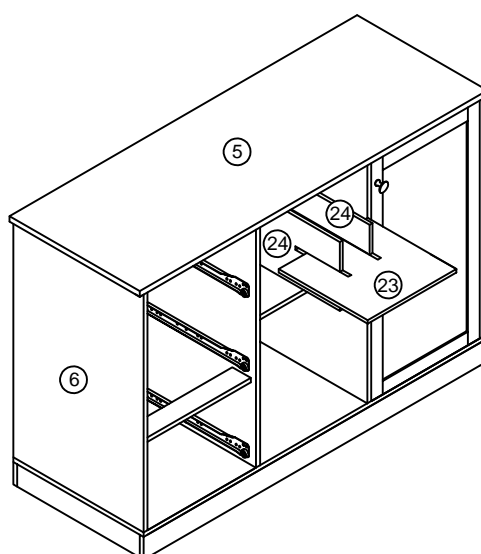

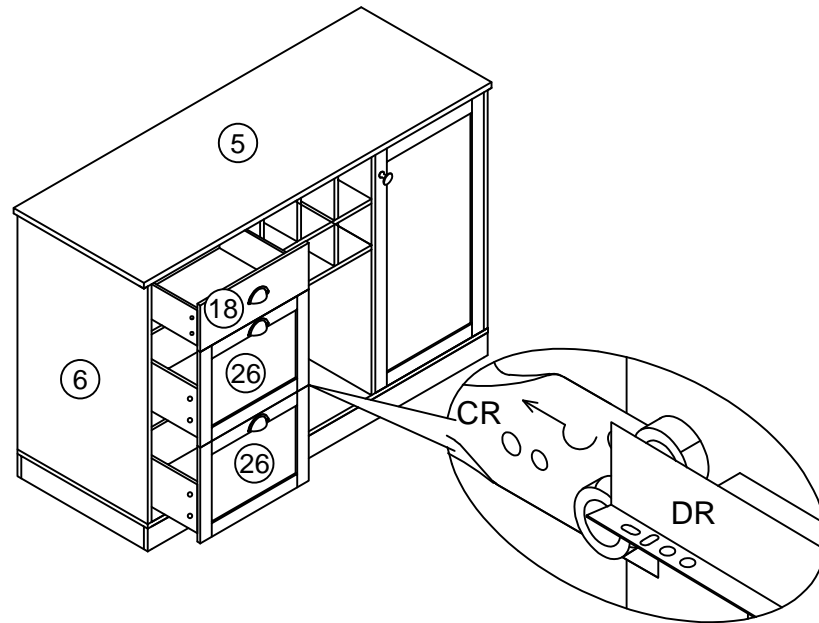

STEP 30/SCHRITT 30/Étapes 30/Passo 30/Paso 30



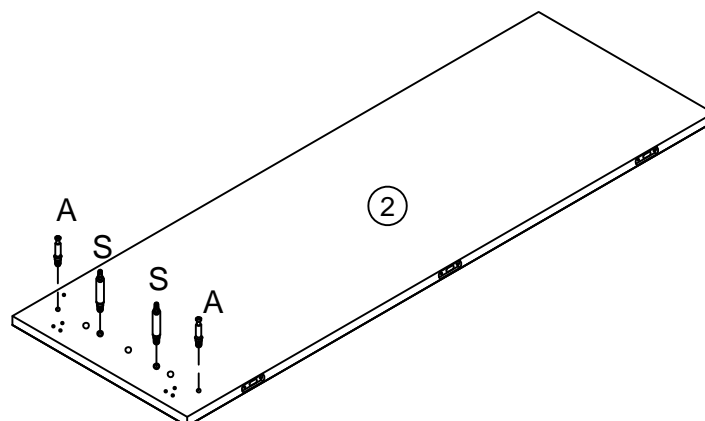

STEP 31/SCHRITT 31/Étapes 31/Passo 31/Paso 31



	
A x 2pcs	S x 2pcs

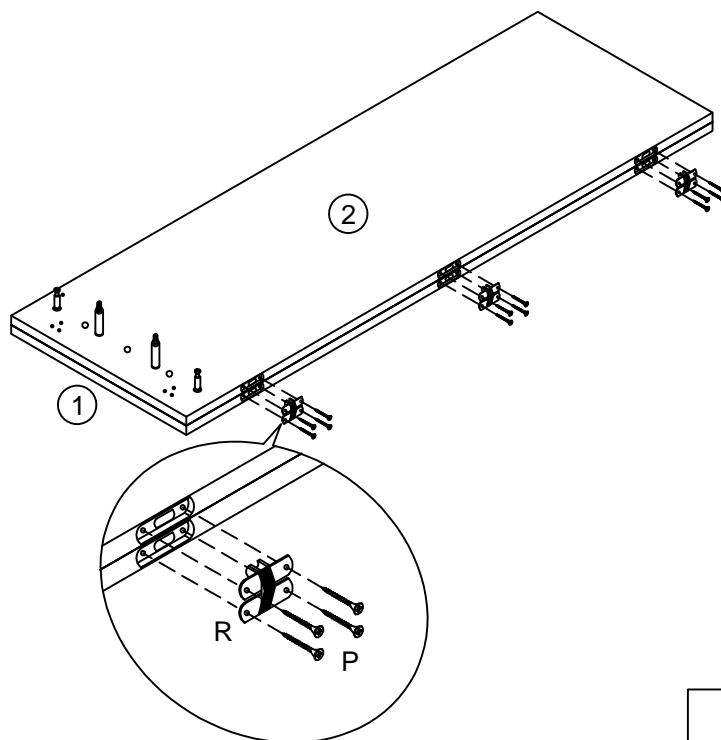

STEP 32/SCHRITT 32/Étapes 32/Passo 32/Paso 32



	
P x 12pcs	R x 3pcs

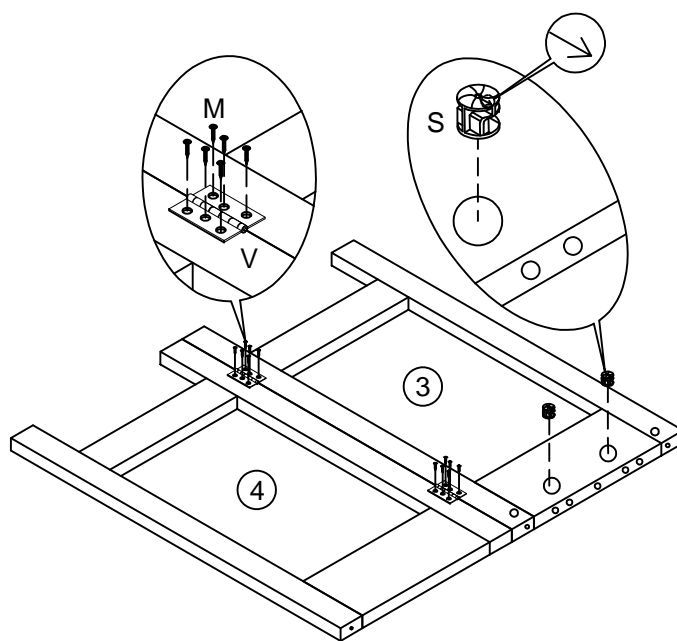

STEP 33/SCHRITT 33/Étapes 33/Passo 33/Paso 33



		
M x 12pcs	S x 2pcs	V x 2pcs

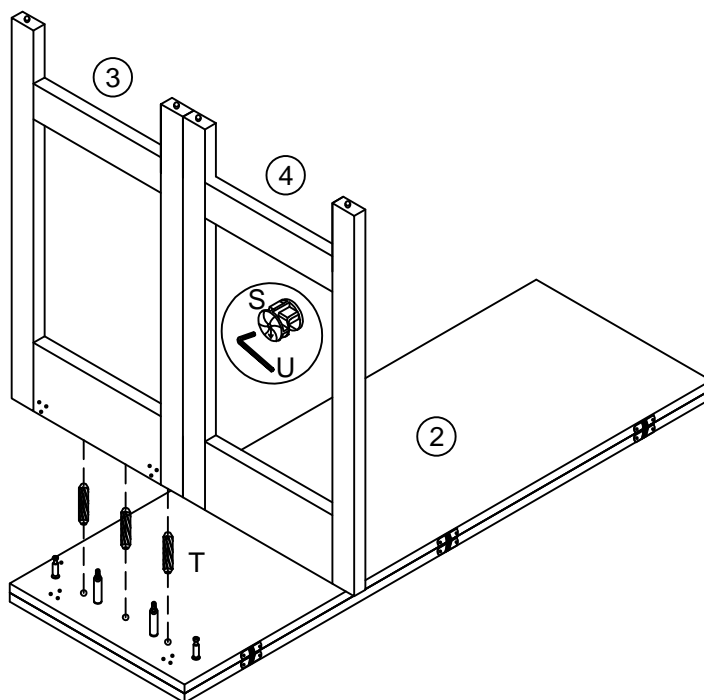

STEP 34/SCHRITT 34/Étapes 34/Passo 34/Paso 34

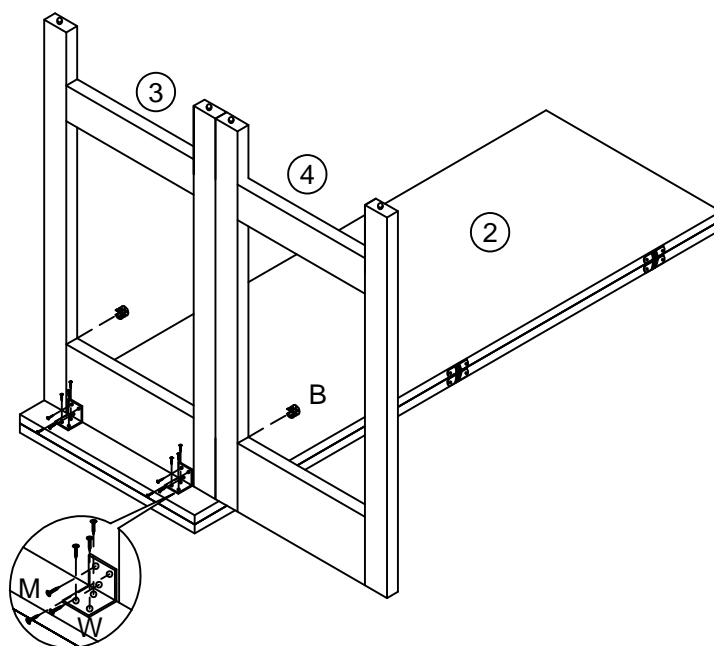

	
T x 3pcs	U x 1pc

STEP 35/SCHRITT 35/Étapes 35/Passo 35/Paso 35



		
B x 2pcs	M x 12pcs	W x 2pcs

STEP 36/SCHRITT 36/Étapes 36/Passo 36/Paso 36

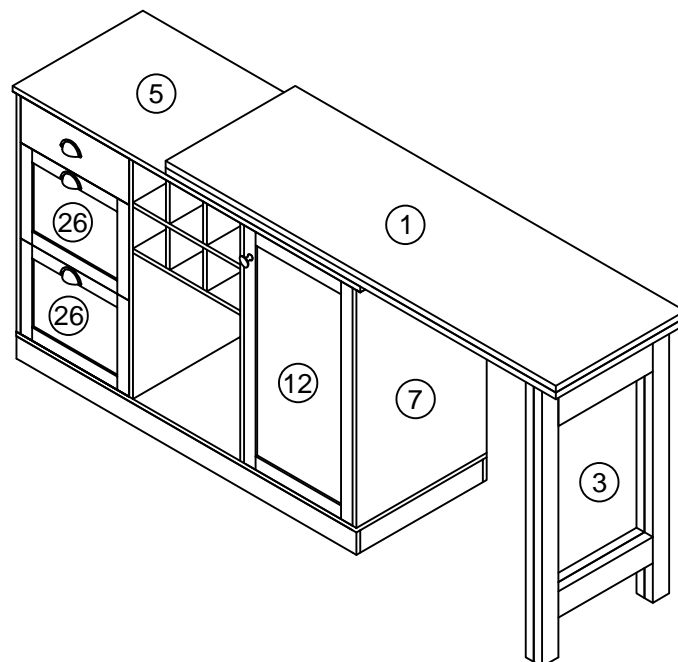
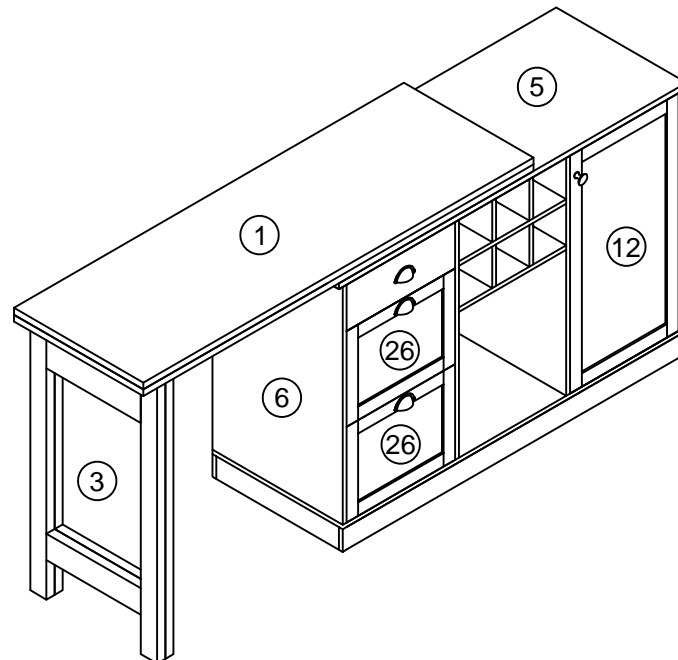

STEP 37/SCHRITT 37/Étapes 37/Passo 37/Paso 37

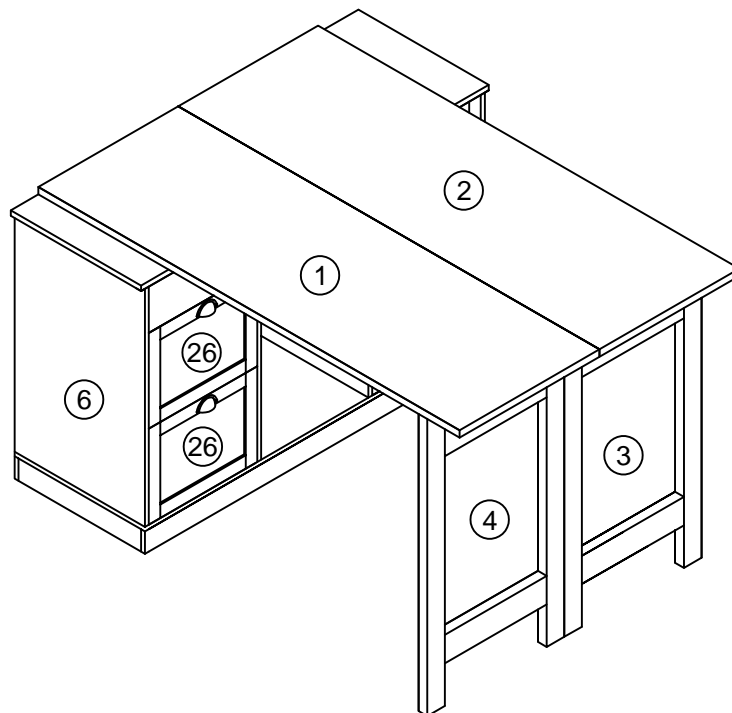
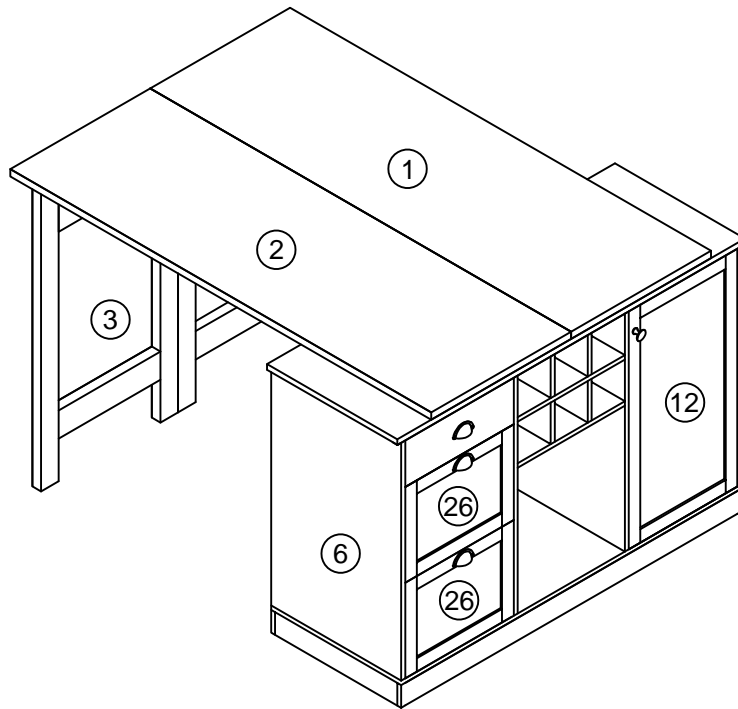

DE:Vor dem Einbau die Schrauben in die Löcher stecken und festziehen, aber nicht bis 100%, 70% bis 80% anziehen reicht aus. Schließlich, nachdem alle Schrauben installiert sind, ziehen Sie alle Schrauben auf 100%.

Wenn Sie auf diese Probleme stoßen, wie z. B. Fehlausrichtung der Löcher oder Unfähigkeit, bestimmte Teile zu installieren, überprüfen Sie bitte, ob die Schrauben korrekt verwendet werden und passen Sie die Dichtigkeit der Schrauben an.

UK:Before installation, insert the screws into the holes and tighten them, but do not tighten them to 100%, 70% to 80% is sufficient. Finally, after all screws are installed, tighten all screws to 100%.If you encounter these issues, such as if the holes cannot be aligned or some parts cannot be installed, please check if the screws are used correctly and adjust the tightness of the screws.

FR:Insérer la vis dans le trou avant la fin de l'assemblage, serrer la vis, mais ne pas serrer à 100%, 70% ~ 80% est correct. Enfin, une fois que toutes les vis sont bien serrées, toutes les vis sont serrées à 100%.

Si vous rencontrez ces problèmes, par exemple si les trous ne sont pas alignés ou si certaines pièces ne peuvent pas être montées, vérifiez que les vis sont utilisées correctement et Ajustez leur serrage.

IT: Prima dell'installazione, inserire le viti nei fori e stringerle, ma non al 100%, è sufficiente stringerle al 70% - 80%. Infine, dopo aver installato tutte le viti, stringere tutte le viti al 100%. Se riscontri problemi come disallineamenti dei fori o difficoltà nell'installare alcuni componenti, verifica che le viti siano utilizzate correttamente e regola la tensione delle viti.

ES: Antes de la instalación, coloque los tornillos en los agujeros y apriéte los, pero no al 100% apretar al 70% - 80% es suficiente. Finalmente, después de haber instalado todos los tornillos, apriete todos los tornillos al 100%. Si se encuentra con problemas como desalineación de los agujeros o dificultad para instalar ciertas piezas, verifique que los tornillos se estén utilizando correctamente y ajuste la tensión de los tornillos.

NL: Voordat u begint met de installatie, plaatst u de schroeven in de gaten en draait u ze aan, maar draai ze niet volledig aan; 70% tot 80% is voldoende. Draai uiteindelijk, nadat alle schroeven zijn geplaatst, alle schroeven volledig aan. Als u problemen ondervindt, zoals niet uitgelijnde gaten of onderdelen die niet kunnen worden geïnstalleerd, controleer dan of de schroeven correct zijn gebruikt en pas de spanning van de schroeven aan.

SE: Innan installation, sätt i skruvarna i hålen och dra åt dem, men dra inte åt dem helt; 70% till 80% är tillräckligt. Slutligen, när alla skruvar är installerade, dra åt alla skruvar helt. Om du stöter på problem, som att hålen inte kan justeras eller vissa delar inte kan installeras, kontrollera om skruvarna används korrekt och justera skruvarnas åtdragning.

PL: Przed instalacją wstaw śruby w otwory i dokręć je, ale nie dokręcaj ich na 100%; 70% do 80% wystarczy. Na koniec, po zainstalowaniu wszystkich śrub, dokręć wszystkie śruby do 100%. Jeśli napotkasz problemy, takie jak niedopasowane otwory lub części, które nie mogą być zainstalowane, sprawdź, czy śruby są używane prawidłowo i dostosuj ich dokręcenie.