

**SKU N620P348477+N620P348478**

Dieses Produkt wird in zwei Kartons geliefert. Wir empfehlen, es nach dem Erhalt aller Kartons zusammenzubauen.

Importeur	Decobus Handel GmbH
Adresse	Innungsstraße 9, 21244 Buchholz, Deutschland
URL	<a href="https://www.decobusgroup.de">https://www.decobusgroup.de</a>
Hersteller	ZHANGZHOU XINZUOBIAO INDUSTRY & TRADE CO., LTD.
Adresse	BeidouIndustrial Zone, ZhangzhouCity, Fujian Province, China
Email/URL	<a href="mailto:2092167066@qq.com">2092167066@qq.com</a>
Partienummer	N620P348477+N620P348478
Hergestellt in	China
<b>EC REP</b>	Decobus Handel GmbH Innungsstraße 9, 21244 Buchholz, Deutschland <a href="https://www.decobusgroup.de">https://www.decobusgroup.de</a>



Importeur	Decobus Handel GmbH
Adresse	Innungsstraße 9, 21244 Buchholz, Deutschland
Email/URL	<a href="https://www.decobusgroup.de">https://www.decobusgroup.de</a>
Hersteller	Shenzhen Pinchengxin Technology co., Ltd
Adresse	3rd floor, 8 building Yuanling industrialzon, No. 39 Yuanlingcun road, Shiyao
Email/URL	<a href="mailto:fosm11@foxmail.com">fosm11@foxmail.com</a>
Partienummer	2025/08
Hergestellt in	China
<b>EC REP</b>	Decobus Handel GmbH Innungsstraße 9, 21244 Buchholz, Deutschland <a href="https://www.decobusgroup.de">https://www.decobusgroup.de</a>
	Produkt: 5050 RGB LED Strip Lights Modell: 5050RGB 60D/M 5V 10MM Nennspannung : 5V Nennfrequenz: 60HZ Leistung : 28W

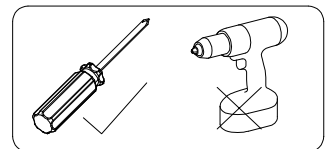
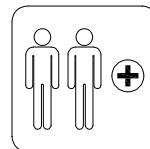
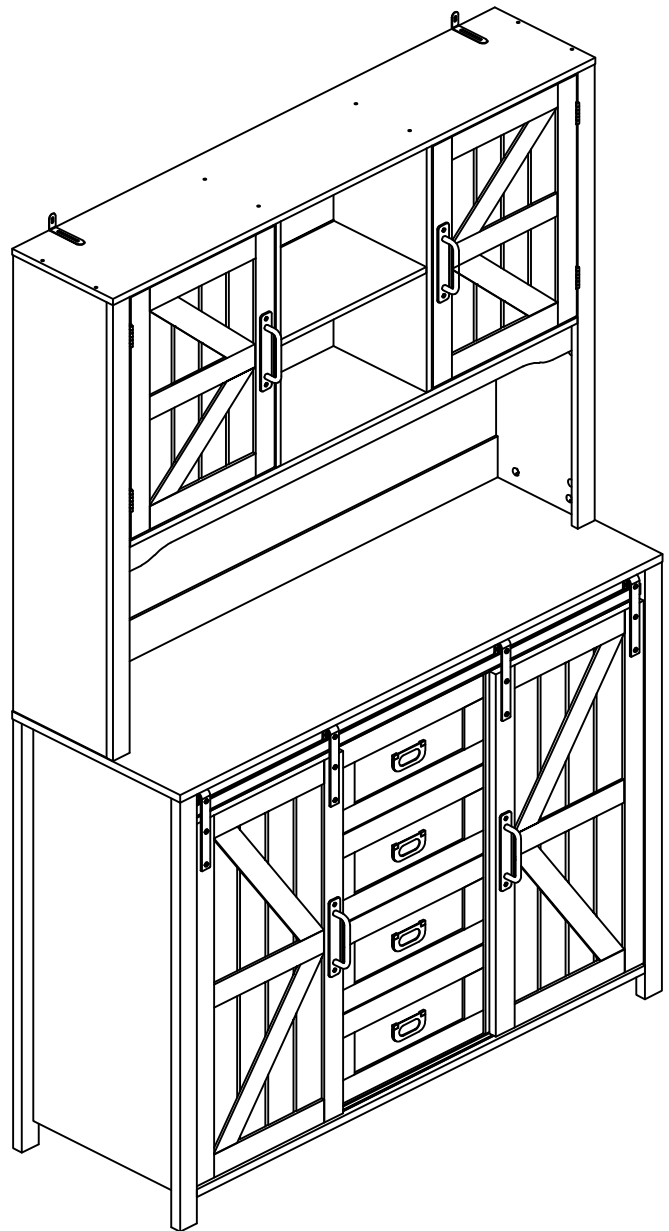

**EN\_IMPORTANT,RETAIN FOR FUTURE REFERENCE;READ CAREFULLY.  
FR\_IMPORTANT:A LIRE ATTENTIVEMENT ET ACONSERVER POUR CONSULTATION  
ULTERIEURE.  
ES\_IMPORTANTE,LEA Y GARDE PARA FUTURAS REFEREBCUAS.  
DE\_„,WICHTIG!SORGEALTIG LESEN UND FUR SPATER NACHSCHLAGEN AUFBEWAHREN."  
IT\_IMPORTANTE! CONSERVARE IL PRESENTE MANUALE PER FUTURO RIFERIMENTO E  
LEGGERLO ATTENTAMENTE.**

**EN**

Dear customer,

Thank you for purchasing this product. So that your appliance serves you well, please read all the instructions in this user's manual. If you have any questions, please contact our customer care center.

**FR**

Cher client,

Nous vous remercions d'avoir acheté ce produit. Afin que vous puissiez profiter pleinement de votre appareil, veuillez lire toutes les instructions de ce manuel d'utilisation. Si vous avez la moindre question, veuillez contacter notre centre d'assistance à la clientèle.

**DE**

Sehr geehrter Kunde,

Vielen Dank, dass Sie dieses Produkt erworben haben. Damit Ihr Gerät Ihnen gute Dienste leistet, lesen Sie bitte alle Hinweise in diesem Benutzerhandbuch. Wenn Sie Fragen haben, wenden Sie sich bitte an unser Kundendienstzentrum.

**ES**

Queridos clientes,

Gracias por comprar este producto. Para que su electrodoméstico le sirva mejor, lea todas las instrucciones de este manual del usuario. Si tiene alguna pregunta, comuníquese con nuestro Centro de Atención al Cliente.

**IT**

Caro Cliente,

Grazie per aver acquistato questo prodotto. Per servirti meglio con questo apparecchio ti prego di leggere tutte le istruzioni in presente manuale utente. In caso di dubbio, si prega di contattare il nostro centro assistenza clienti.

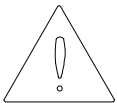

Our product will be delivered to you in 2 packages. The delivery times of these 2 packages may differ, please be patient and thank you for your understanding.

Unser Produkt wird Ihnen in 2 Paketen geliefert. Die Lieferzeiten dieser 2 Pakete können abweichen, bitte haben Sie etwas Geduld und vielen Dank für Ihr Verständnis.

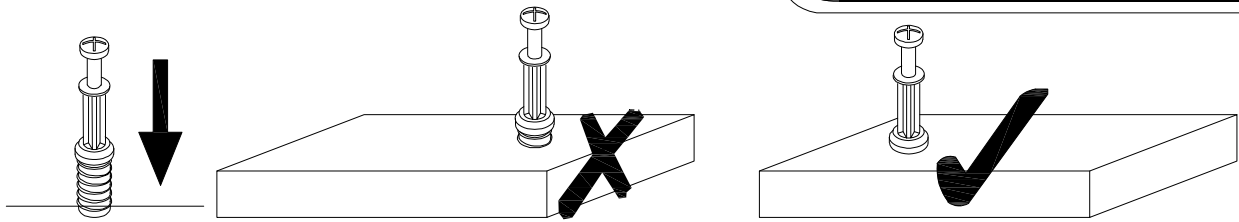

EN\_QUICKFIT:Tighten quickfit until shoulder is flush with panel.Do not overtighten or undertighten.

FR\_RACCORD RAPIDE:Faites serrer le raccord rapide jusqu'a ce que l'epaulement soit parfaitement encstre dans le panneau.Il ne faut ni trop serrer ni insuffisamment serrer.

ES\_QUICKFIT:Apriete quickfit hasta que el hombre se descargue con el panel.NO lo sobreapriete ni lo apriete poco.

DE\_QUICKFIT:Ziehen Sie den quickfit fest,bis die Schulter mit der Platte bundig ist. Bitte nicht zu fest oder zu schwach anziehen.

IT\_MONTAGGIO RAPIDO:Stringere il montaggio rapido fino aquando la spalla e a filo con il pannello,non stringere troppo o troppo poco.

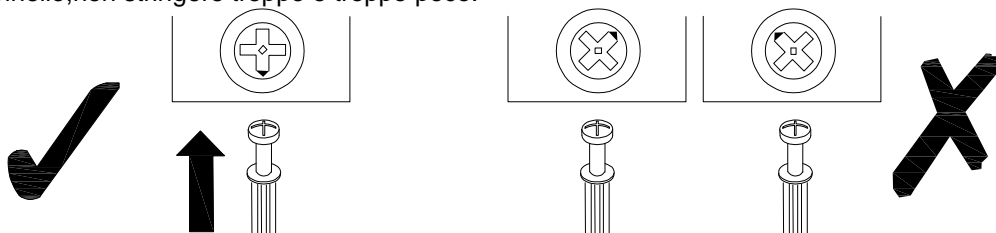

EN\_CAM LOCK:When fitting cam lock,ensure starting position is correct before you insert connecting quickfit.

FR\_SERRURE BATTEUSE:Avant d'inserer la serrure batteuse,veillez a la bonne orientation avant d'inserer le raccord rapide,

ES\_CIERRE DE LA CAMARA:Cuando instale el cierre de la camara,asegurese de que la posicion de inicio es correcta antes de que inserte el quickfit conector,

De\_CAM-LOCK:Achten Sie bei der Montage des Cam-locks auf die richtige Ausgangsposition,bevor Sie den Quickfit einsetzen.

IT\_BLOCCAGGIO A CAMMA:Quando si monta il bloccaggio a camma,assicurarsi che la posizione iniziale sia corretta prima di inserire il montaggio rapido di collegamento.

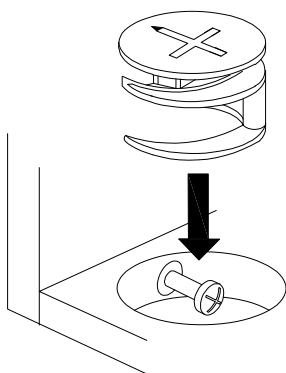

EN\_Quickfit head should be in the centre of the cam lock when the two panels are joined.

Cam lock should be inserted before quickfit.

FR\_Lorsque les deux panneaux sont assembles,la tete du raccord rapide doit reposer au centre de la serrure batteuse. Il faut inserer la serrure batteuse avant le raccord rapide.

ES\_EL cabezal del quickfit debe estar en el centro del cierre de la camara cuando se unan los dos paneles.

Se debe insertar el cierre de la camara antes que el quickfit.

DE\_Der Quickfit-Kopf sollte sich in der Mitte des Cam-locks befinden,wenn die beiden Platten zusammengefugt sind.

Der Cam-lock sollte vor dem Quickfit eingesetzt werden.

IT\_La testa del montaggio rapido deve trova rsi al centro del bloccaggio a camma quando i due pannelli sono uniti.

Il Bloccaggio a Camma deve essere inserito prima del montaggio rapido.

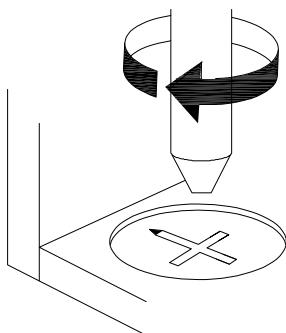

EN\_Turn cam lock clockwise to tighten.

FR\_Faites tourner la serrure batteuse dans le sens des aiguilles d'une montre pour la resserrer.

ES\_Gire el cierre de la camara en sentido horario para apretarlo.

DE\_Drehen Sie den Cam-Lock im Uhrzeigersinn,um ihn festzuziehen.

IT\_Rutotare il bloccaggio a camma in senso oragio per stringere.

## DE

1. Die maximale Tragfähigkeit der Oberplatte beträgt 60 kg, bitte nicht überladen.
2. Lassen Sie Kinder nicht auf Möbeln klettern, da dies zu Umstürzen und schweren Verletzungen führen kann.
3. Um die Sicherheit zu gewährleisten, installieren Sie bitte gemäß der Anleitung und ziehen Sie bei Bedarf Fachleute hinzu.
4. Stellen Sie Möbel nicht in die Nähe von Feuerquellen oder heißen Gegenständen, um Brandgefahr zu vermeiden.
5. Stellen Sie Möbel nicht in feuchten Umgebungen auf, um Materialschäden zu verhindern.
6. Überprüfen Sie regelmäßig alle Verbindungs- und Befestigungselemente, um sicherzustellen, dass sie fest sitzen und Unfälle zu vermeiden.
7. Dieses Produkt ist mit einem Kipp-Schutz ausgestattet, installieren Sie diesen Schutz, um Verletzungen durch Umstürzen zu vermeiden.

## UK

1. The maximum weight capacity of the top panel is 60kg; please do not overload.
2. Do not allow children to climb on furniture, as this may cause tipping and serious injury.
3. To ensure safety, please install correctly according to the instructions and seek professional assistance if necessary.
4. Do not place furniture near fire sources or hot objects to avoid fire hazards.
5. Do not place furniture in damp environments to prevent material damage.
6. Regularly check all connectors and fasteners to ensure they are secure to prevent accidents.
7. This product comes with an anti-tipping device; install this device to prevent injuries from tipping.

## IT

1. La capacità massima del pannello superiore è di 60 kg; non sovraccaricare.
2. Non permettere ai bambini di arrampicarsi sui mobili, poiché ciò può causare ribaltamenti e gravi infortuni.
3. Per garantire la sicurezza, installare correttamente secondo le istruzioni e, se necessario, chiedere assistenza a professionisti.
4. Non posizionare i mobili vicino a fonti di calore o oggetti caldi per evitare rischi di incendio.
5. Non posizionare i mobili in ambienti umidi per prevenire danni ai materiali.
6. Controllare regolarmente tutti i connettori e le viti per assicurarsi che siano saldi e prevenire incidenti.
7. Questo prodotto è dotato di un dispositivo anti-ribaltamento; installare questo dispositivo per evitare infortuni da ribaltamento.

## ES

1. La capacidad máxima del panel superior es de 60 kg; no sobrecargar.
2. No permita que los niños escalen los muebles, ya que esto puede causar volcaduras y lesiones graves.
3. Para garantizar la seguridad, instale correctamente según las instrucciones y busque ayuda profesional si es necesario.
4. No coloque los muebles cerca de fuentes de fuego u objetos calientes para evitar riesgos de incendio.
5. No coloque los muebles en ambientes húmedos para evitar daños en los materiales.
6. Revise regularmente todos los conectores y sujetadores para asegurarse de que estén seguros y prevenir accidentes.
7. Este producto viene con un dispositivo anti-vuelco; instale este dispositivo para prevenir lesiones por vuelcos.

**NL**

1. De maximale draagcapaciteit van het bovenpaneel is 60 kg; niet overbelasten.
2. Laat kinderen niet op meubels klimmen, dit kan leiden tot omvallen en ernstige verwondingen.
3. Installeer correct volgens de instructies om de veiligheid te waarborgen, en schakel indien nodig professionele hulp in.
4. Plaats meubels niet in de buurt van vuurbronnen of warme objecten om brandgevaar te voorkomen.
5. Plaats meubels niet in vochtige omgevingen om materiaalschade te voorkomen.
6. Controleer regelmatig alle verbindingen en bevestigingsmiddelen om ervoor te zorgen dat ze stevig zijn en om ongevallen te voorkomen.
7. Dit product is uitgerust met een kantelbeveiliging; installeer dit apparaat om verwondingen door omvallen te voorkomen.

**SE**

1. Den maximala viktkapaciteten för överpanelen är 60 kg; överbelasta inte.
2. Låt inte barn klättra på möbler, då detta kan orsaka tippning och allvarliga skador.
3. För att säkerställa säkerheten, installera korrekt enligt instruktionerna och sök professionell hjälp om det behövs.
4. Placera inte möbler nära eldkällor eller heta föremål för att undvika brandrisk.
5. Placera inte möbler i fuktiga miljöer för att förhindra skador på materialen.
6. Kontrollera regelbundet alla kopplingar och fästelement för att säkerställa att de är säkra för att förhindra olyckor.
7. Denna produkt levereras med en anti-tippanordning; installera denna anordning för att förhindra skador vid tippning.

**PL**

1. Maksymalne obciążenie górnej płyty wynosi 60 kg; nie przeciążaj.
2. Nie pozwól dzieciom wspinać się na meble, ponieważ może to prowadzić do przewrócenia się i poważnych obrażeń.
3. Aby zapewnić bezpieczeństwo, zainstaluj prawidłowo zgodnie z instrukcją i w razie potrzeby skorzystaj z pomocy profesjonalistów.
4. Nie stawiaj mebli w pobliżu źródeł ognia lub gorących przedmiotów, aby uniknąć ryzyka pożaru.
5. Nie stawiaj mebli w wilgotnych środowiskach, aby zapobiec uszkodzeniu materiałów.
6. Regularnie sprawdzaj wszystkie złącza i elementy mocujące, aby upewnić się, że są stabilne i aby zapobiec wypadkom.
7. Produkt ten jest wyposażony w urządzenie zapobiegające przewróceniu; zainstaluj to urządzenie, aby uniknąć obrażeń w wyniku przewrócenia.

**FR**

1. La charge maximale du panneau supérieur est de 60 kg, ne pas surcharge.
2. Ne laissez pas les enfants grimper sur les meubles, cela peut entraîner des basculements et des blessures graves.
3. Pour garantir la sécurité, installez correctement selon les instructions et demandez l'aide de professionnels si nécessaire.
4. Ne placez pas les meubles près de sources de chaleur ou d'objets chauds pour éviter les risques d'incendie.
5. Ne placez pas les meubles dans des environnements humides pour éviter d'endommager les matériaux.
6. Vérifiez régulièrement tous les connecteurs et les fixations pour vous assurer qu'ils sont bien serrés et éviter les accidents.
7. Ce produit est équipé d'un dispositif anti-basculement; installez ce dispositif pour éviter les blessures dues au basculement.

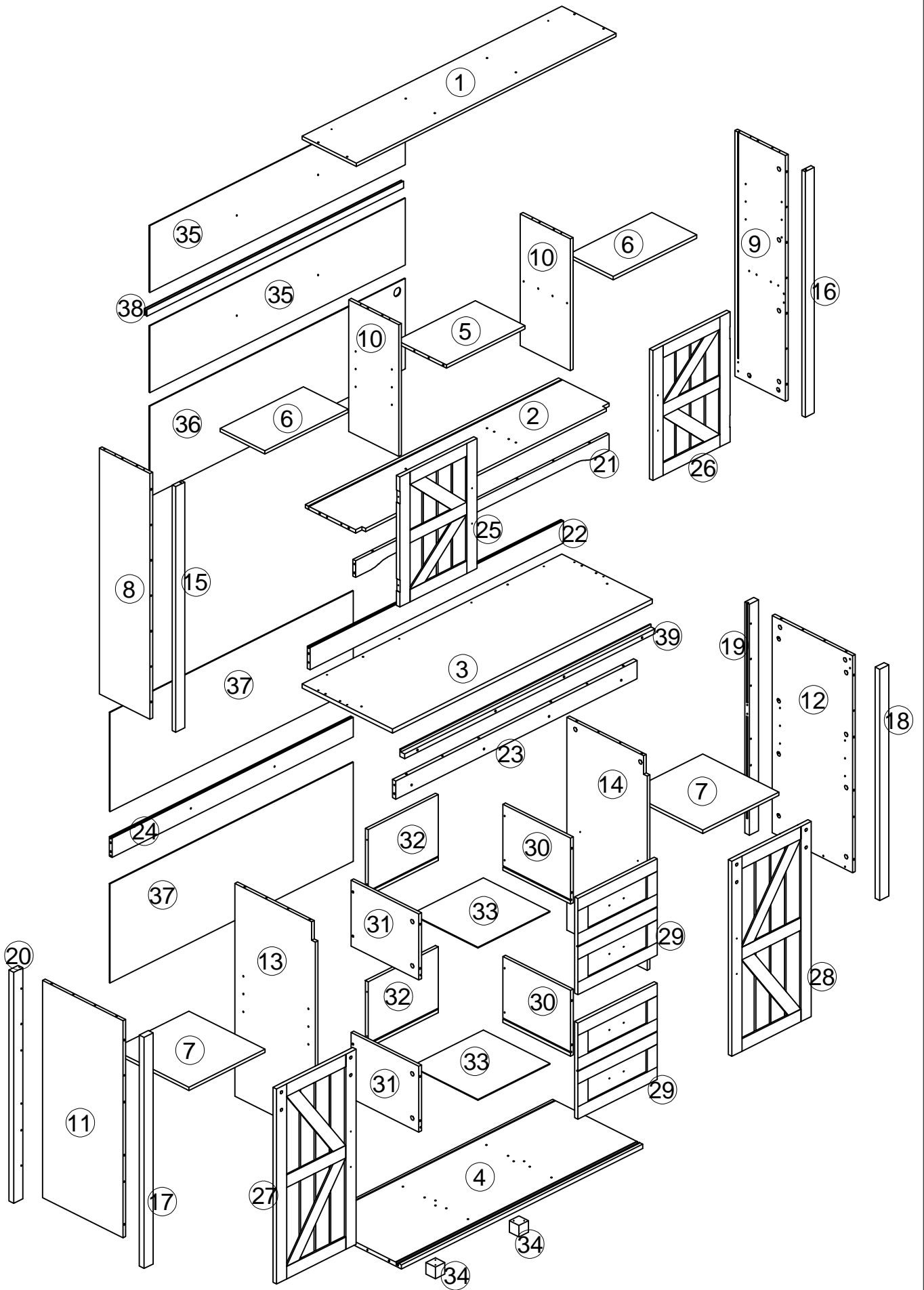

BOX-1/2 SKU N620P348478

NO.	PARTS	QTY
6		x2
7		x2
10		x2
11		x1
12		x1
13		x1
14		x1
25		x1
26		x1
27		x1
28		x1
29		x2
30		x2

BOX-1/2 SKU N620P348478

NO.	PARTS	QTY
31		x2
32		x2
33		x2
BOX		x1
34		x2

BOX-2/2 SKU N620P348477

1		x1
2		x1
3		x1
4		x1
5		x1
8		x1
9		x1
15		x1
16		x1

BOX-2/2 SKU N620P348477

NO.	PARTS	QTY
17		x1
18		x1
19		x1
20		x1
21		x1
22		x1
23		x1
24		x1
35		x2
36		x1
37		x2
38		x1
39		x1

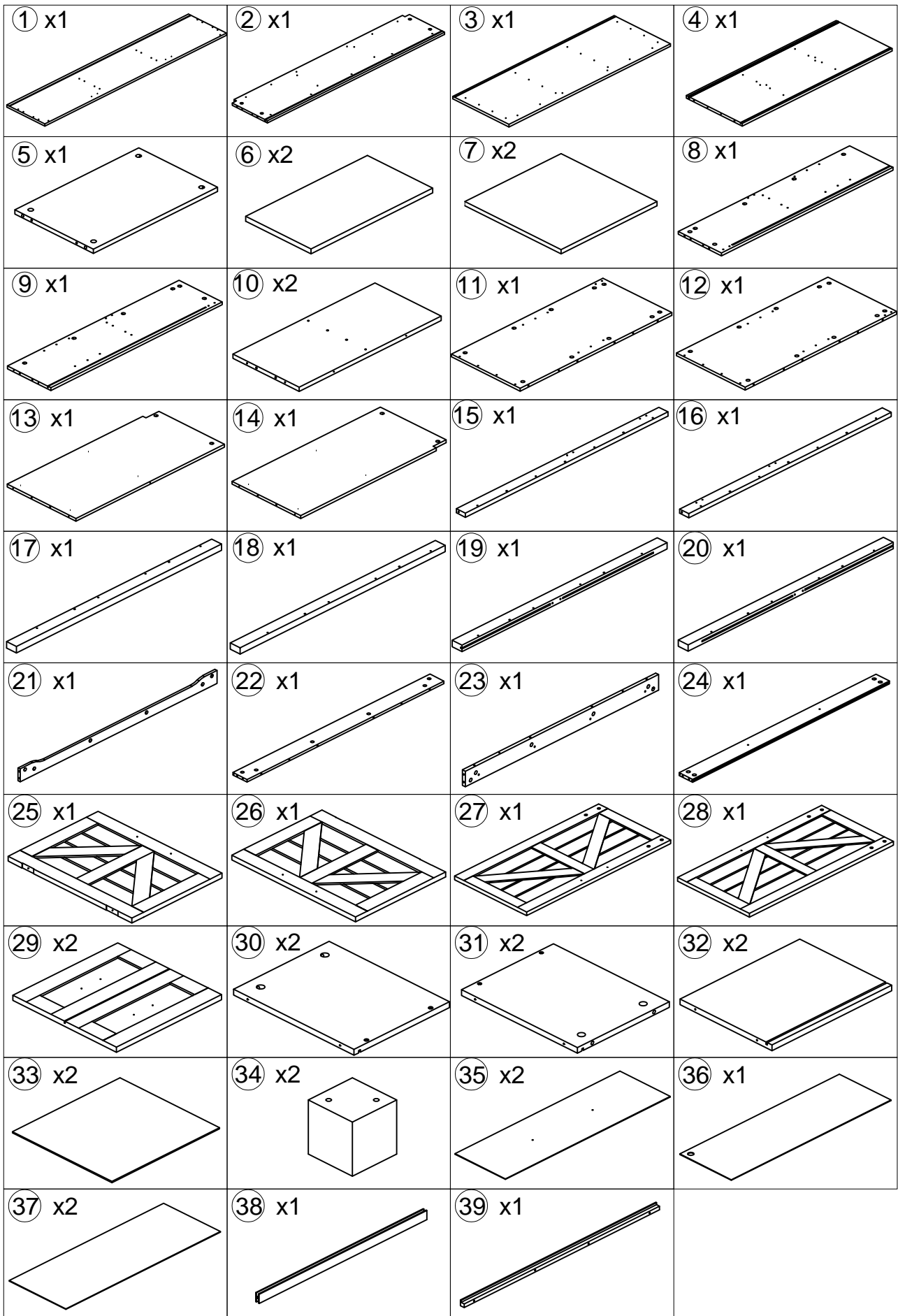

BOX-1/2 SKU N620P348478

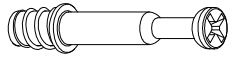
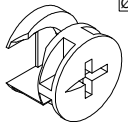
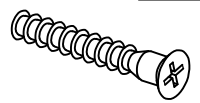
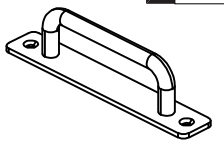
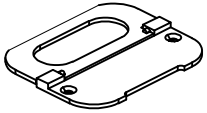
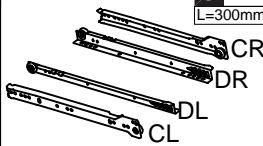
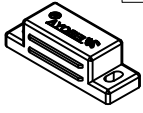
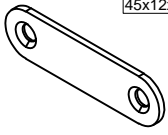
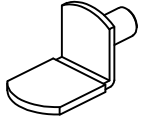
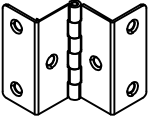
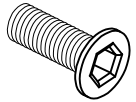
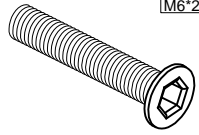
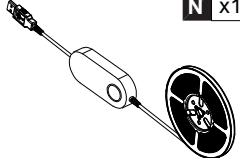
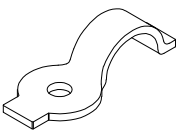
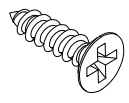
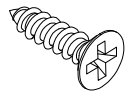
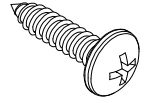
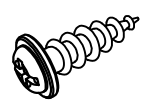
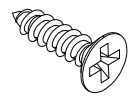
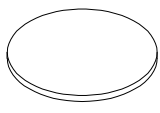
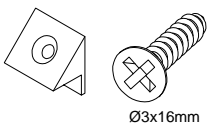
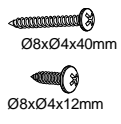
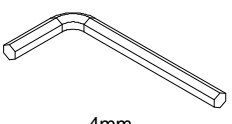
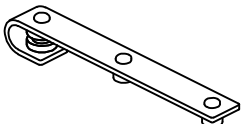
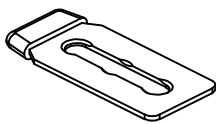
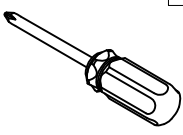
<p><b>A</b> x70+5 Ø6x30mm</p> 	<p><b>B</b> x78+5</p> 	<p><b>C</b> x78+5 Ø15*10mm</p> 	<p><b>D</b> x30+3 Ø5x38mm</p> 	<p><b>E</b> x4</p> 
<p><b>F</b> x4</p> 	<p><b>G</b> x2 L=300mm CR DR DL CL</p> 	<p><b>H</b> x2 45x16x14mm</p> 	<p><b>I</b> x2 45x12x1.3mm</p> 	<p><b>J</b> x16+1</p> 
<p><b>K</b> x4</p> 	<p><b>L</b> x8+1 M6*10mm</p> 	<p><b>M</b> x4+1 M6*20mm</p> 	<p><b>N</b> x1</p> 	<p><b>O</b> x5+1</p> 
<p><b>P</b> x8+1 Ø3x10mm</p> 	<p><b>Q</b> x45+4 Ø3x12mm</p> 	<p><b>R</b> x4+1 Ø3x14mm</p> 	<p><b>S</b> x4+1 Ø3.5x14mm</p> 	<p><b>T</b> x16+1 Ø4x14mm</p> 
<p><b>U</b> x4 40x20x3mm</p> 	<p><b>V</b> x52+3</p> 	<p><b>W</b> x30+2 Ø3x16mm</p> 	<p><b>X</b> x2 Ø8xØ4x40mm Ø8xØ4x12mm</p> 	<p><b>Y</b> x1 4mm</p> 
<p><b>Z</b> x4</p> 	<p><b>AA</b> x4</p> 	<p>x1</p> 		

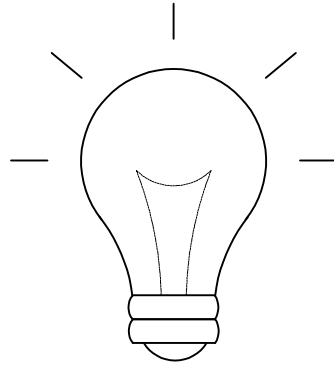

## friendly reminder

To avoid errors and confusion during the installation of accessories, use the type and quantity of hardware accessories according to the installation procedure described in the instructions. First, unroll the accessories bag and lay out the hardware accessories, cut holes in the side, and take out the hardware accessories

Um Fehler und Verwirrung bei der Installation von Zubehör zu vermeiden, verwenden Sie die Art und Menge der Hardware-Zubehörteile gemäß der in der Anleitung beschriebenen Installationsprozedur. Öffnen Sie zunächst den Zubehörbeutel, breiten Sie die Hardware-Zubehörteile aus, schneiden Sie das Loch an der Seite und entnehmen Sie die Hardware-Zubehörteile

Pour éviter les erreurs et la confusion lors de l'installation des accessoires, utilisez le type et la quantité d'accessoires matériels conformément à la procédure d'installation décrite dans les instructions. Tout d'abord, déroulez le sac d'accessoires, étalez les accessoires matériels, coupez les trous sur le côté et retirez les accessoires matériels.

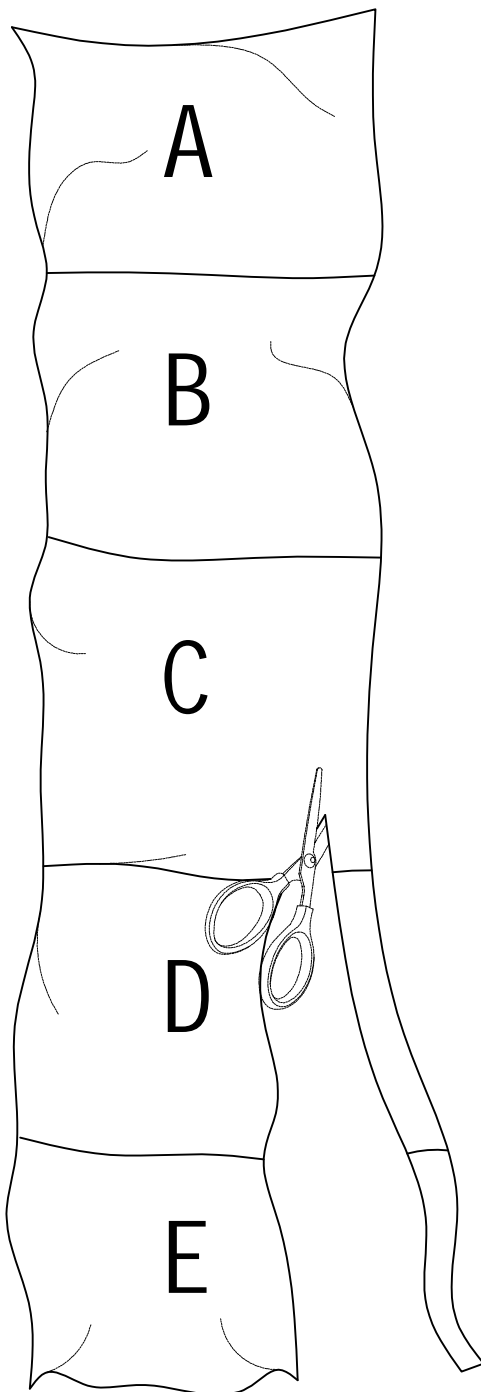

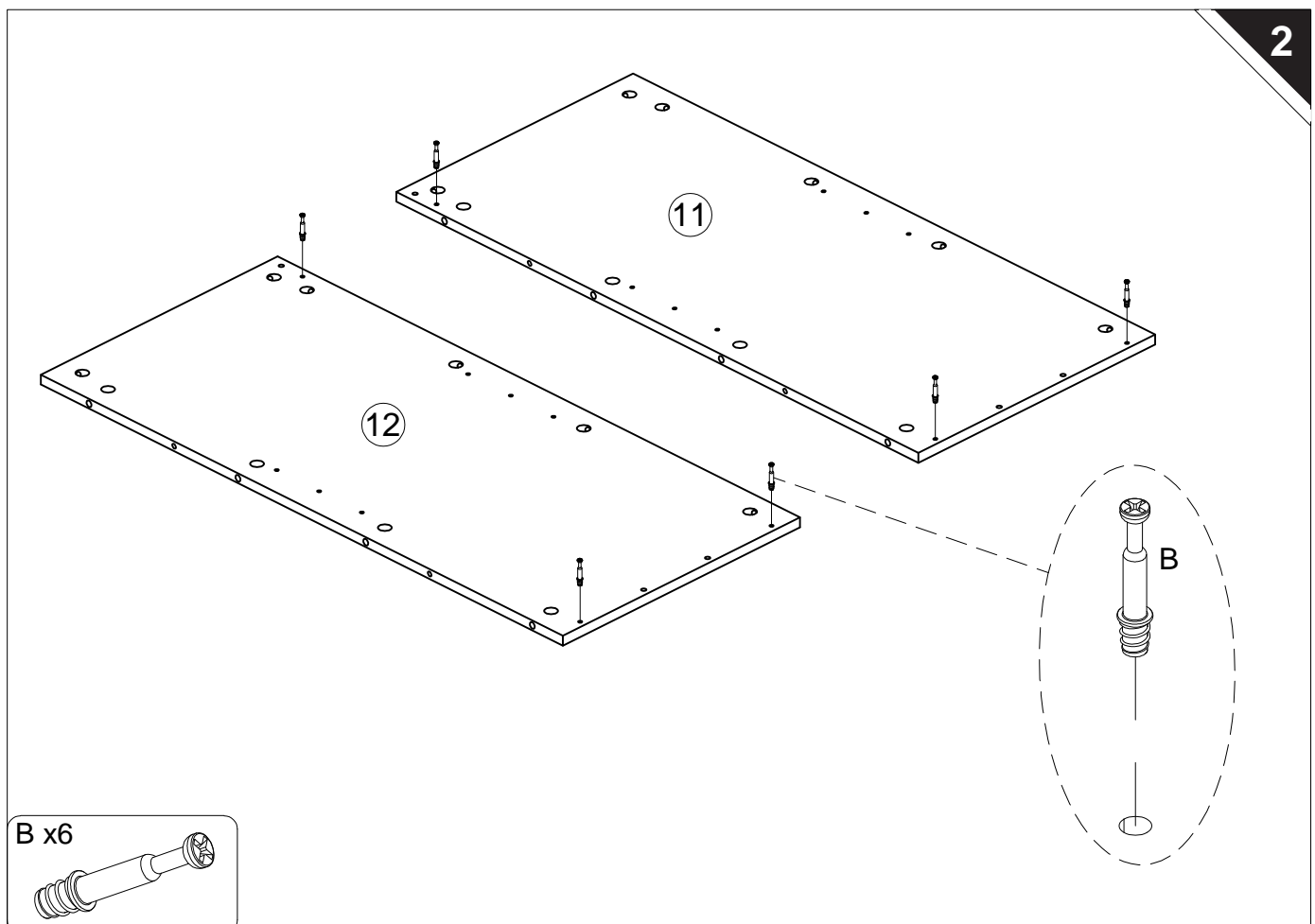
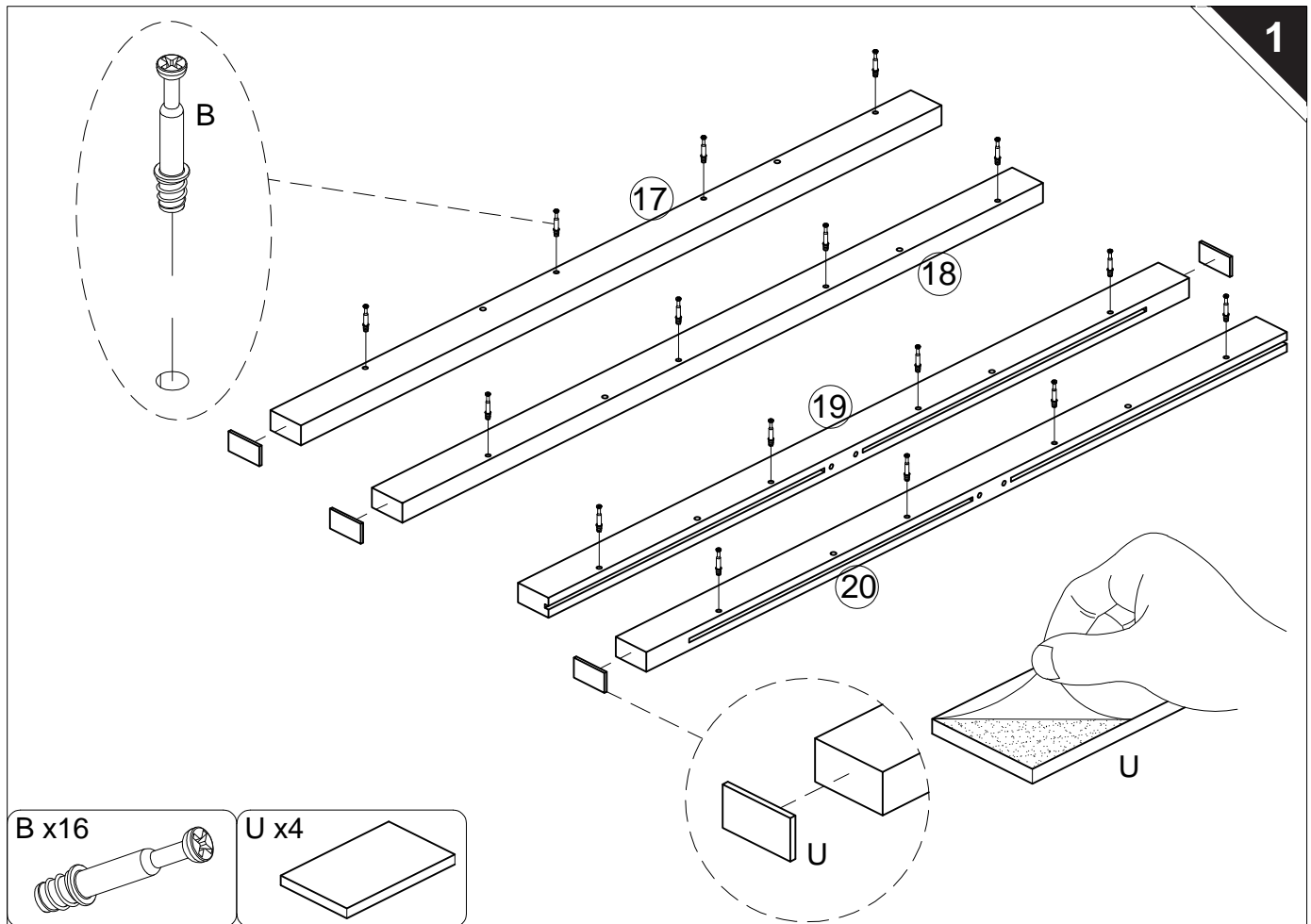

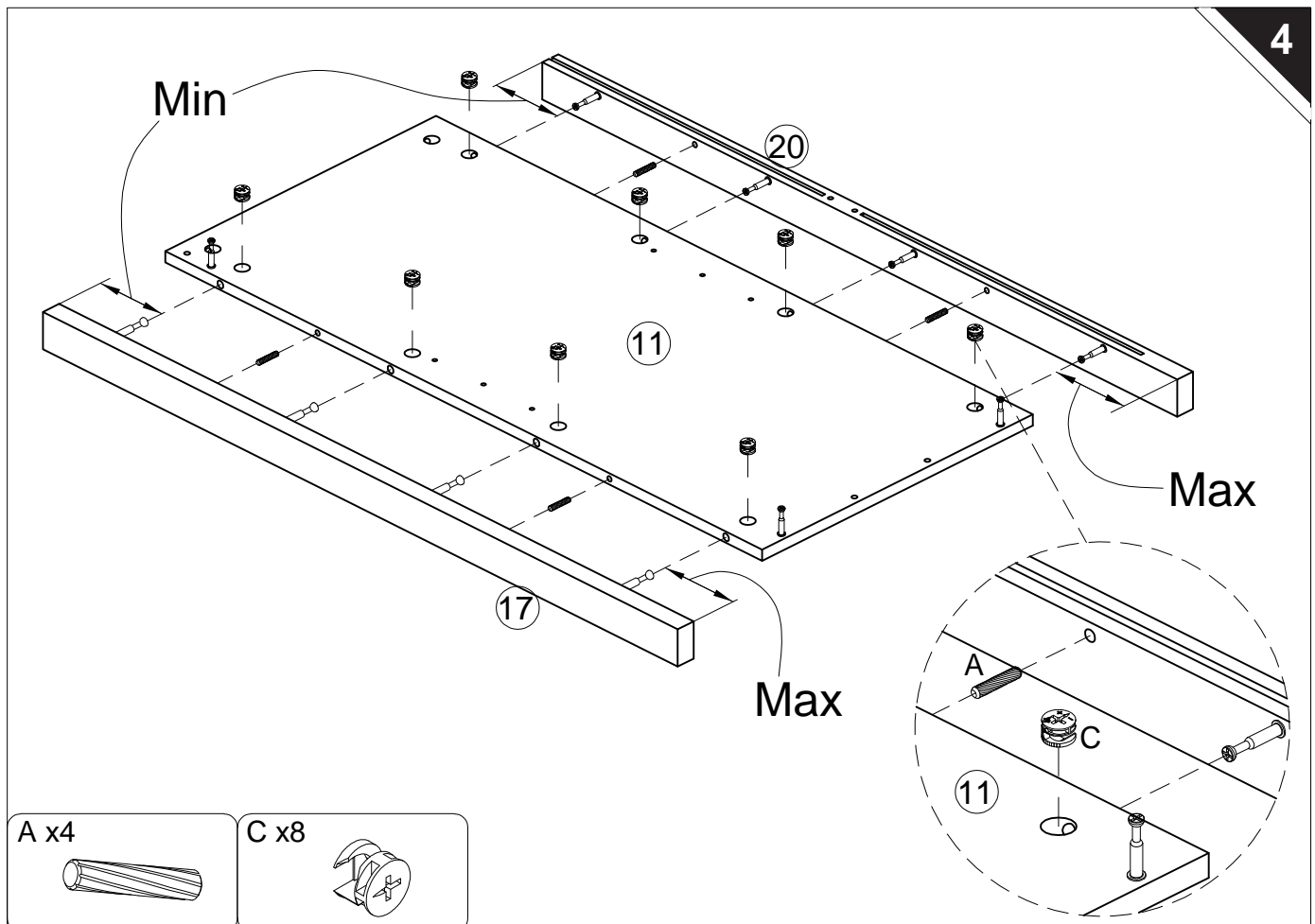
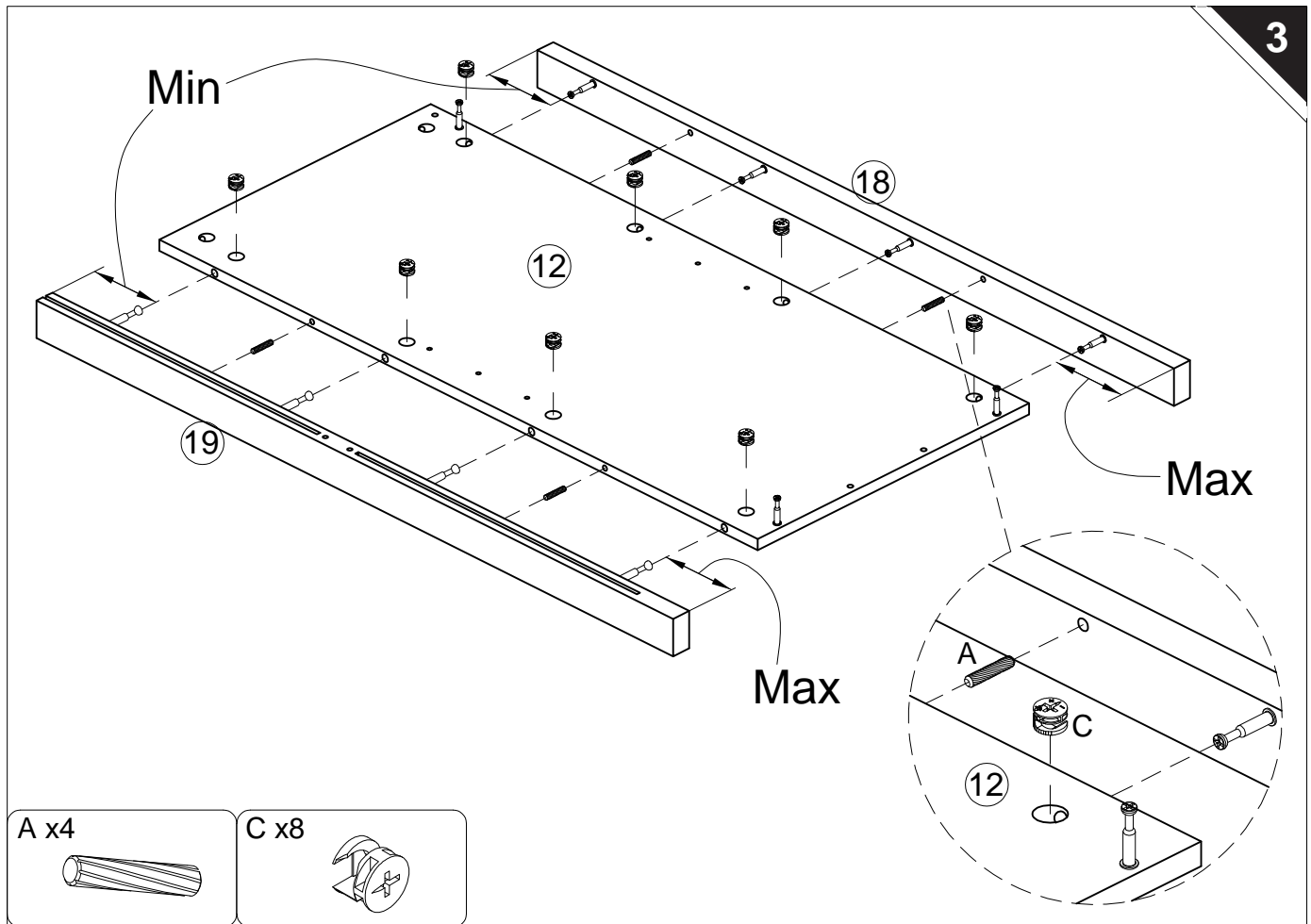

5

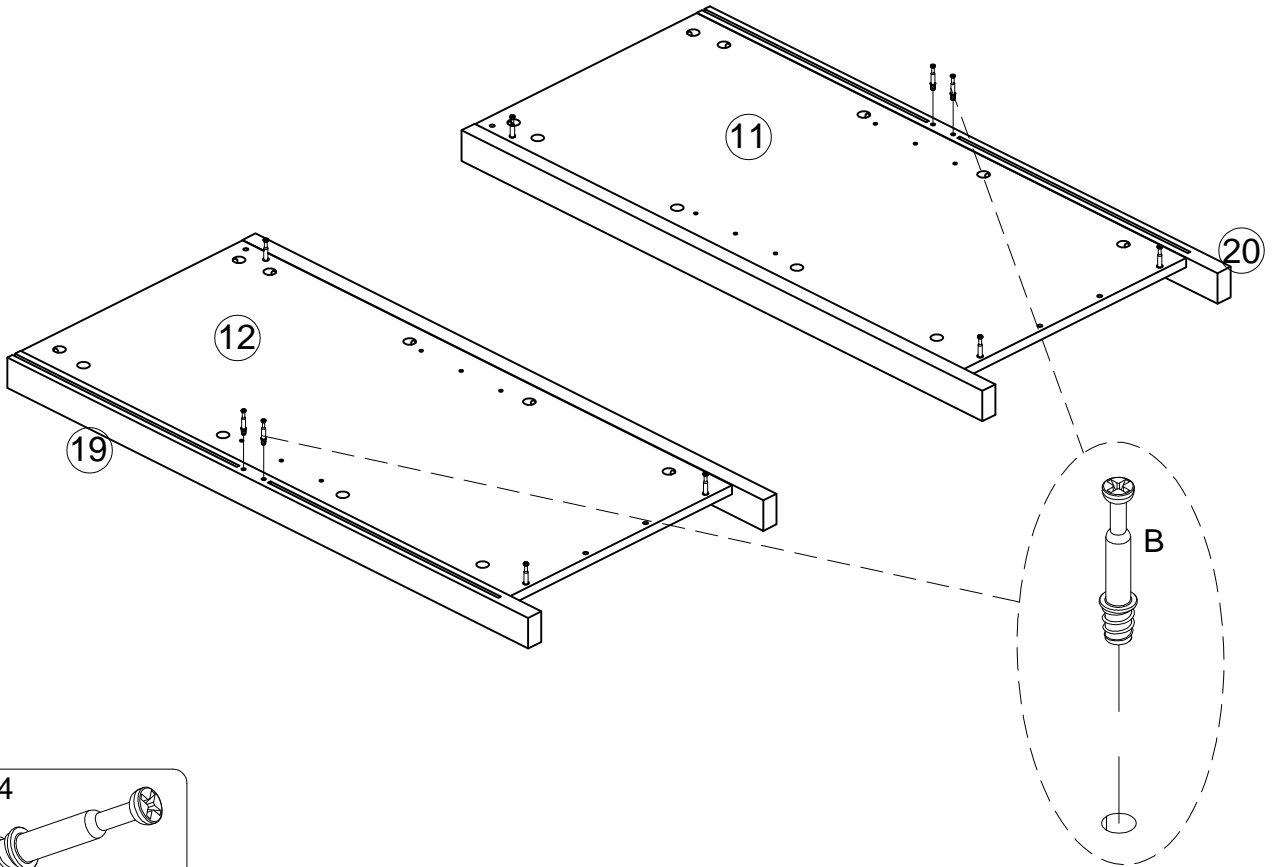

6

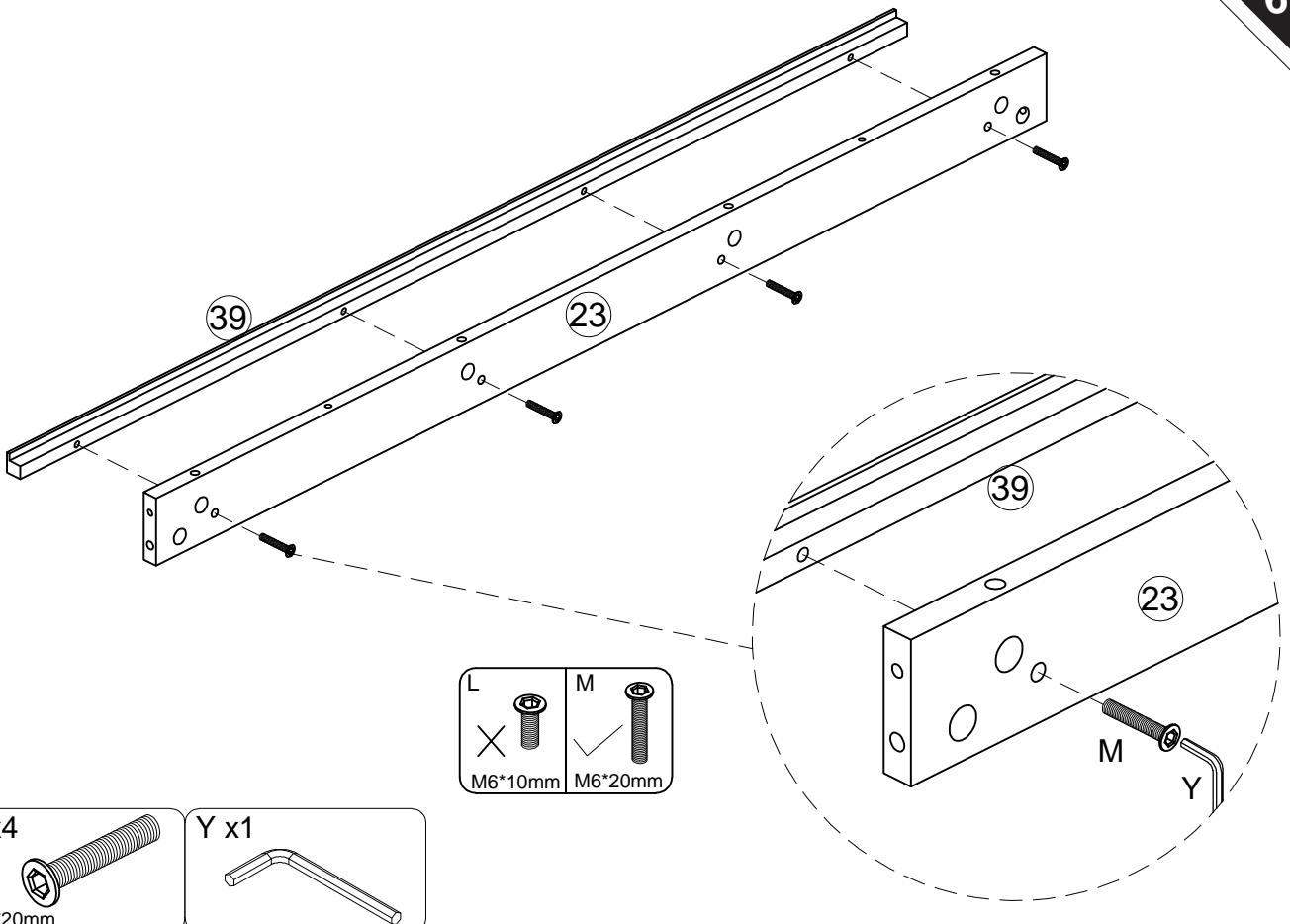

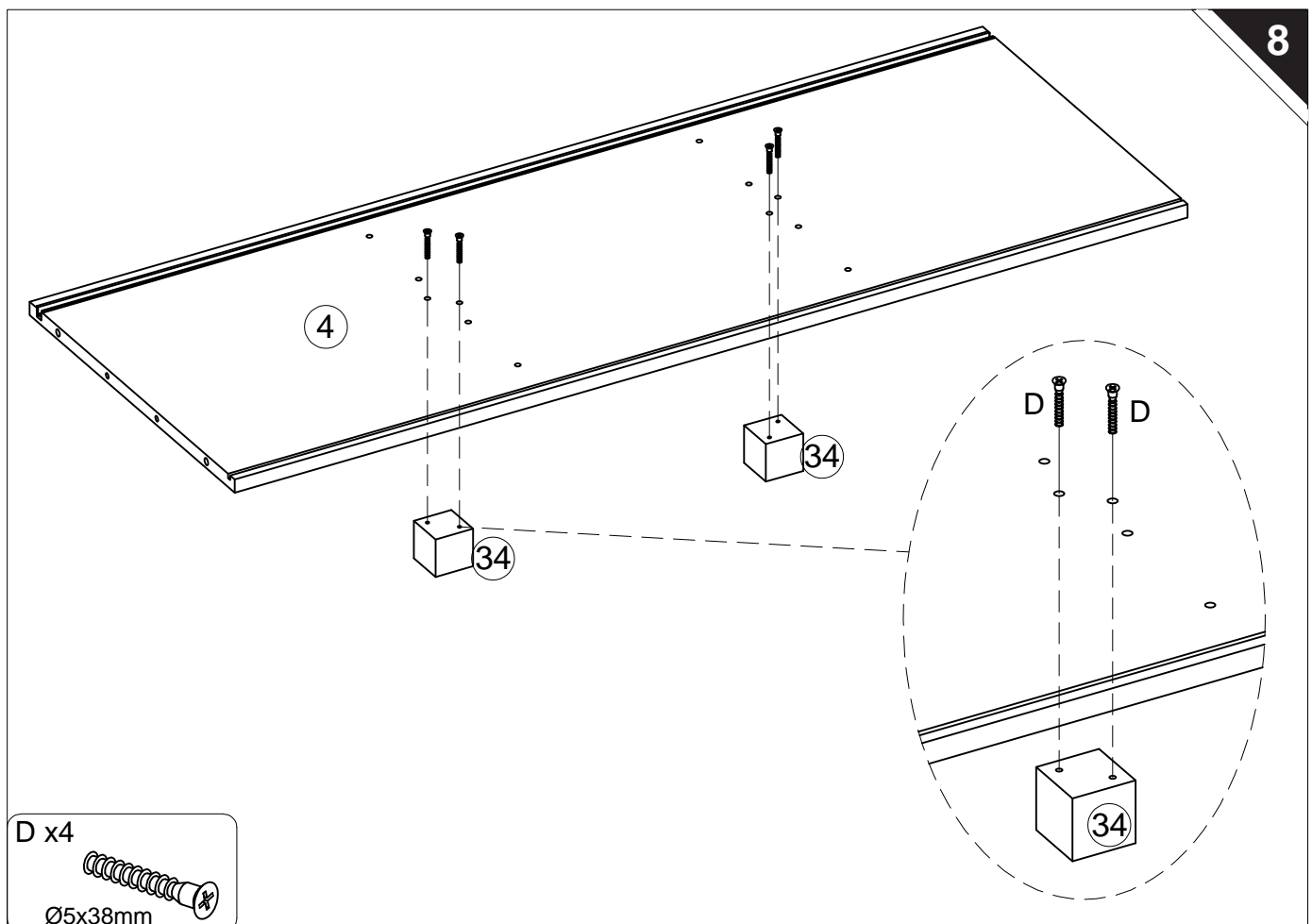
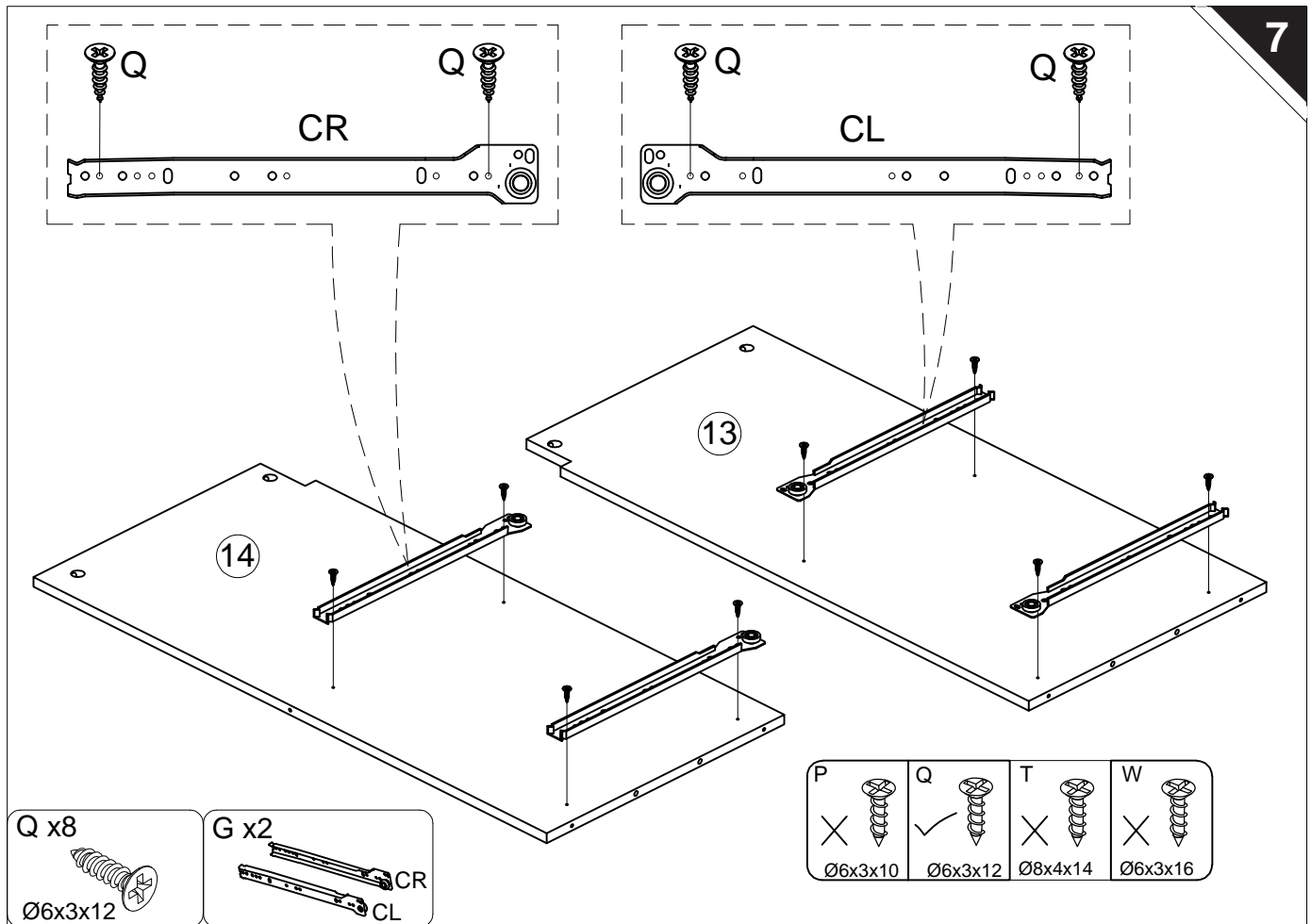

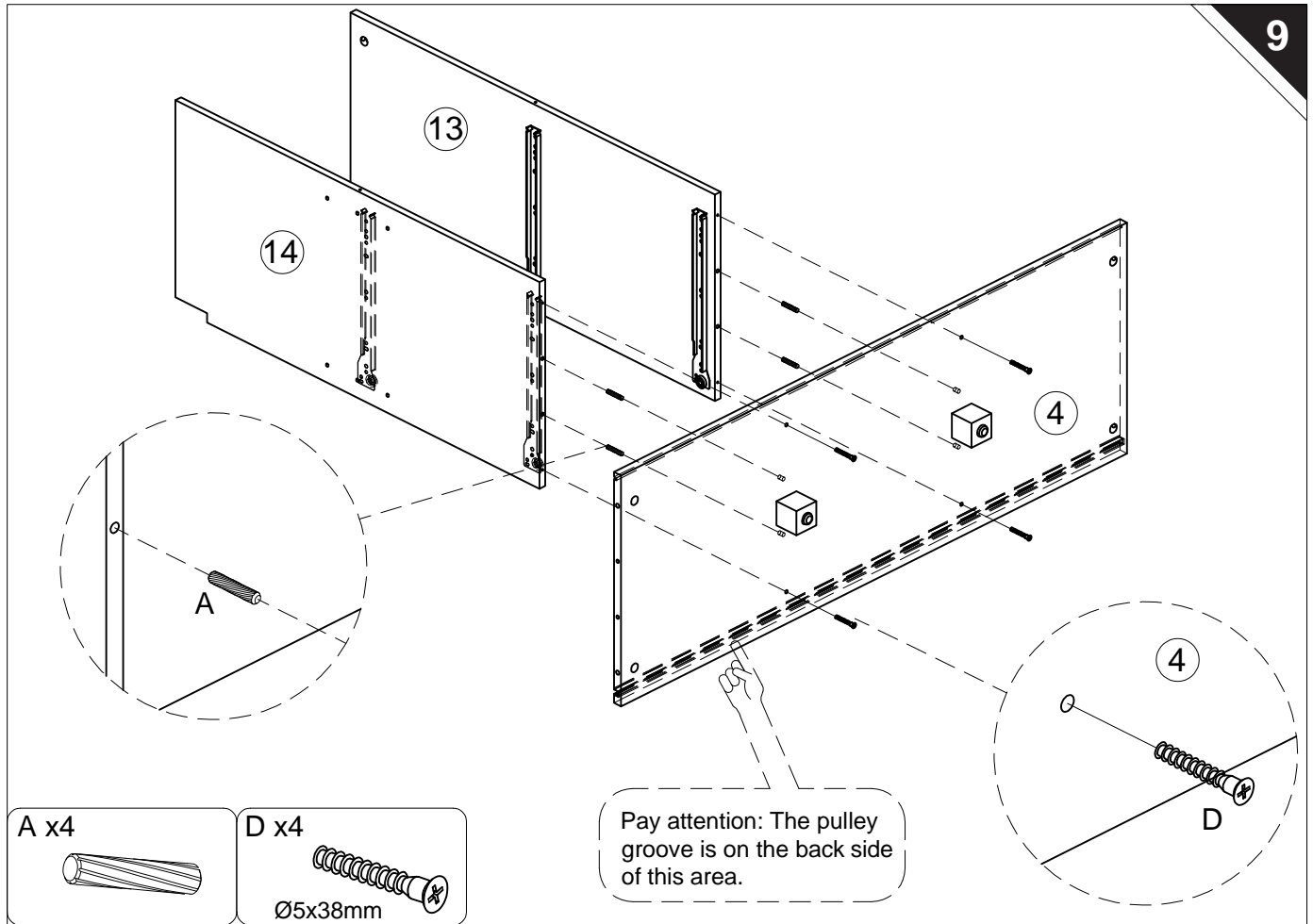

A x4



D x4



Pay attention: The pulley groove is on the back side of this area.

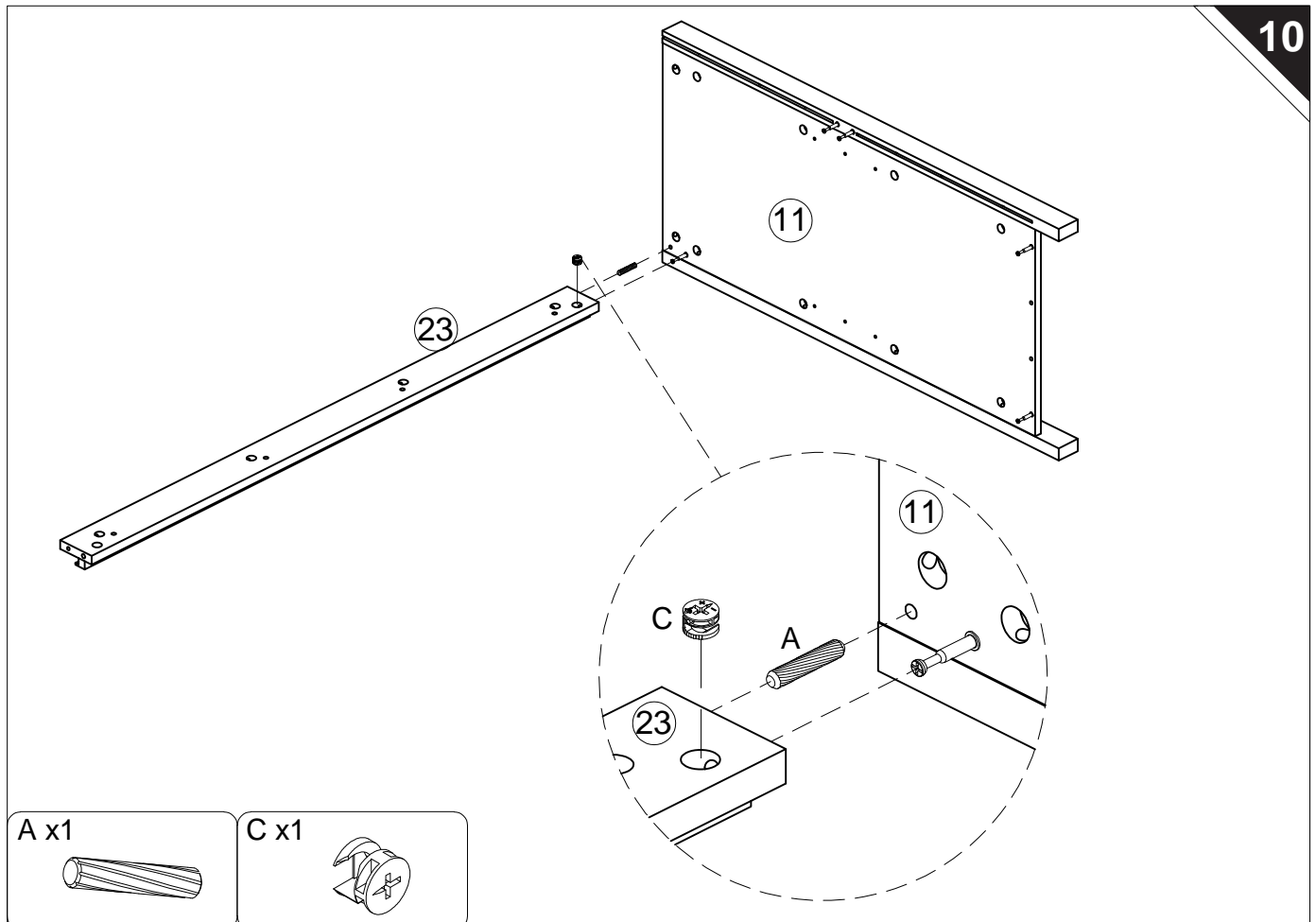

A x1



C x1



The Part #13 and #14 need to be lifted up by hand and placed on top of Part #23.

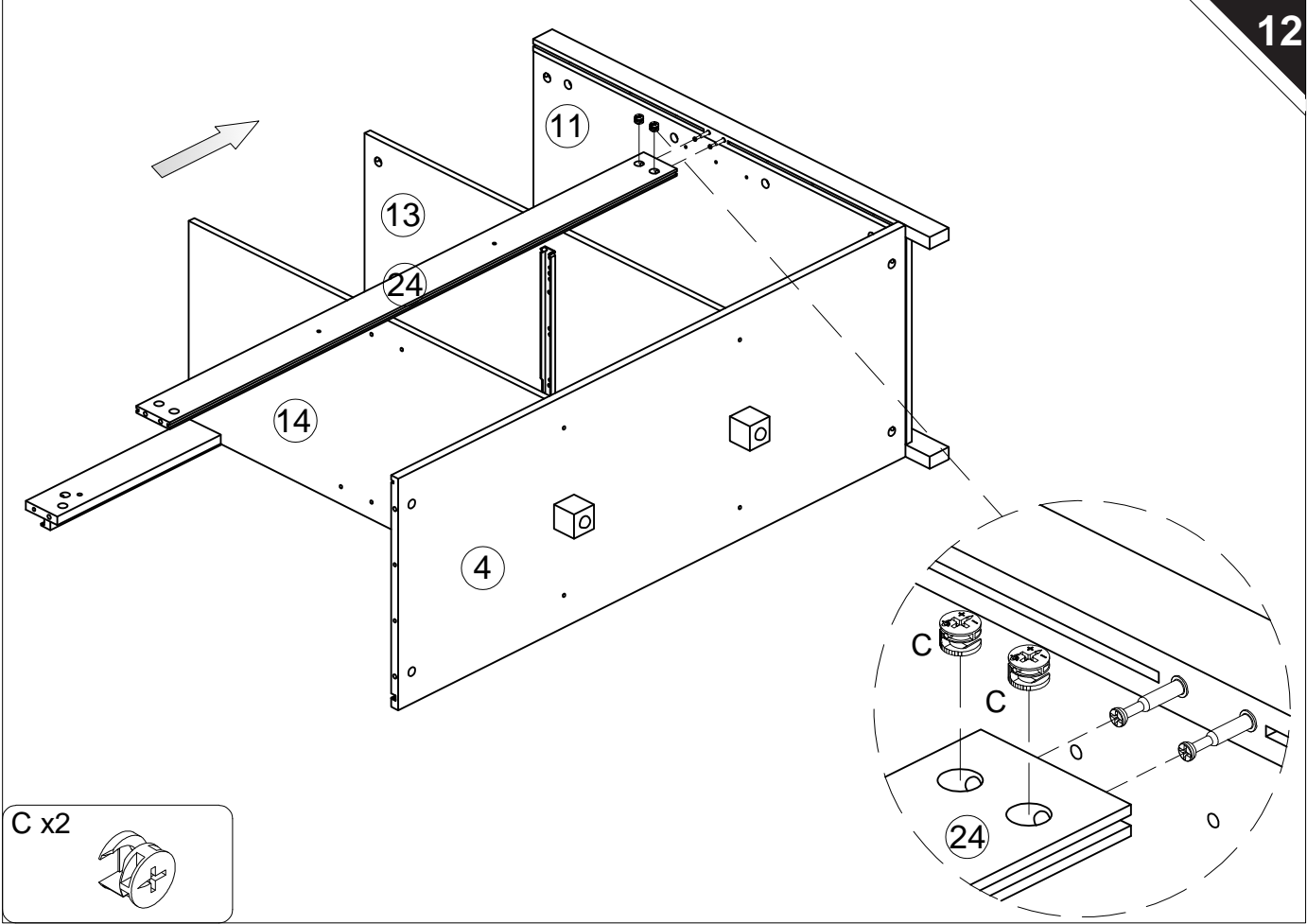
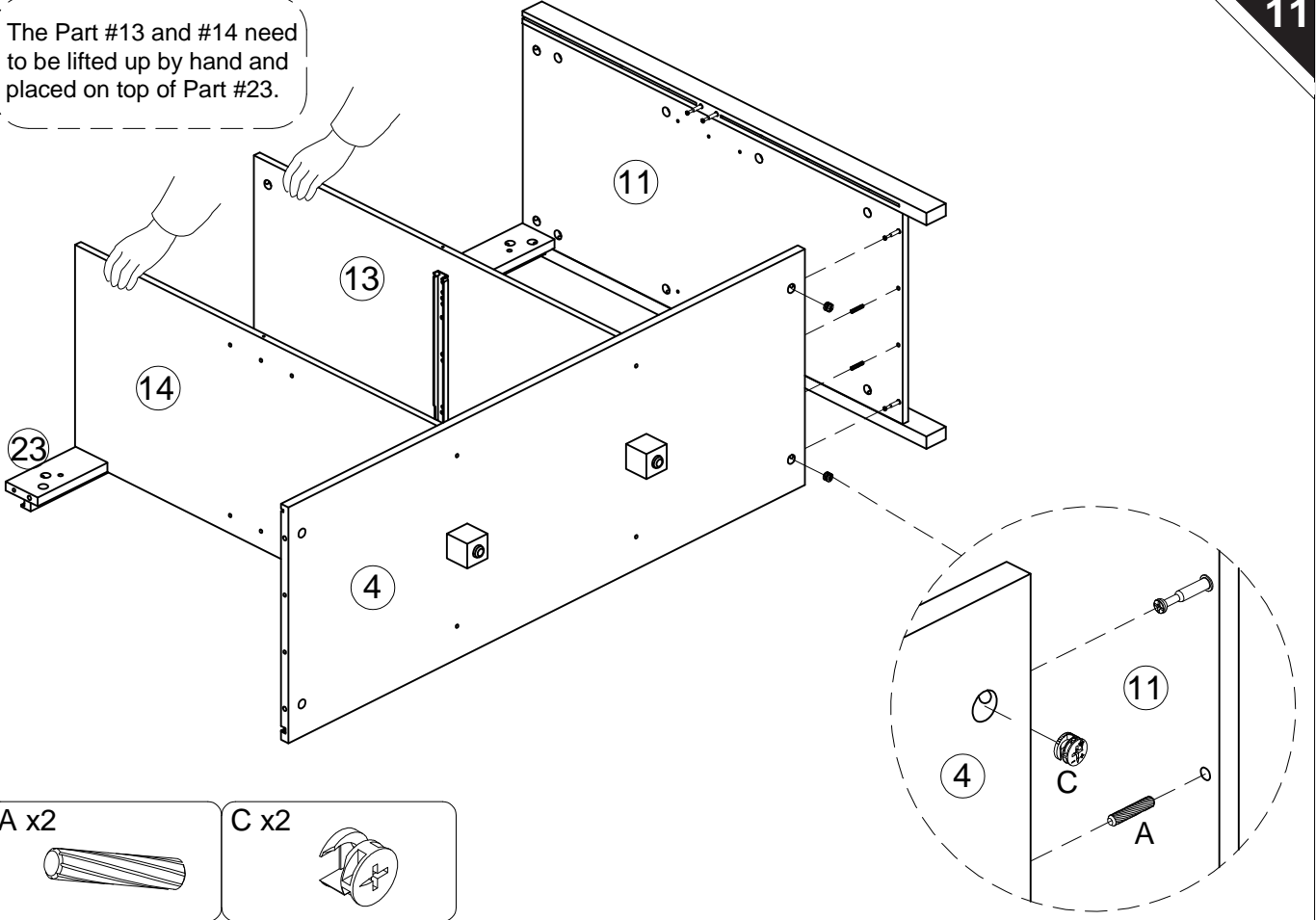

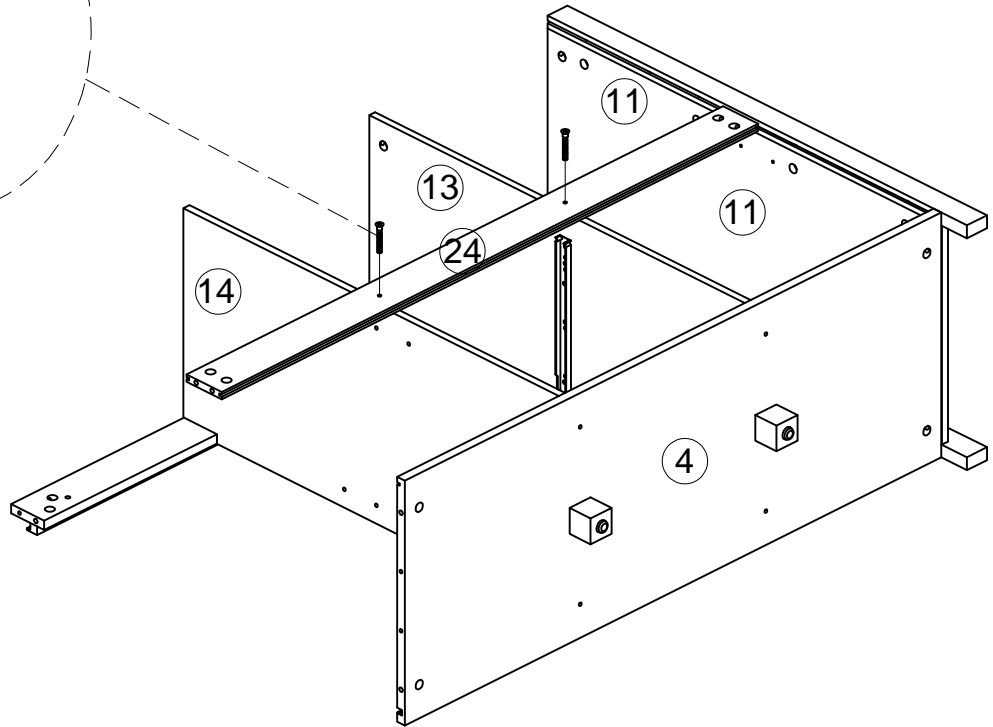
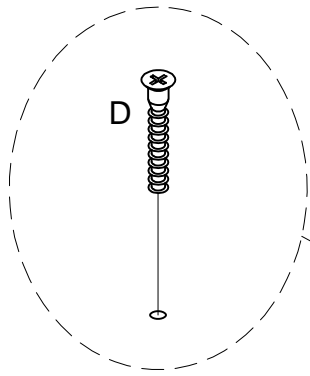

D x2



Ø5x38mm

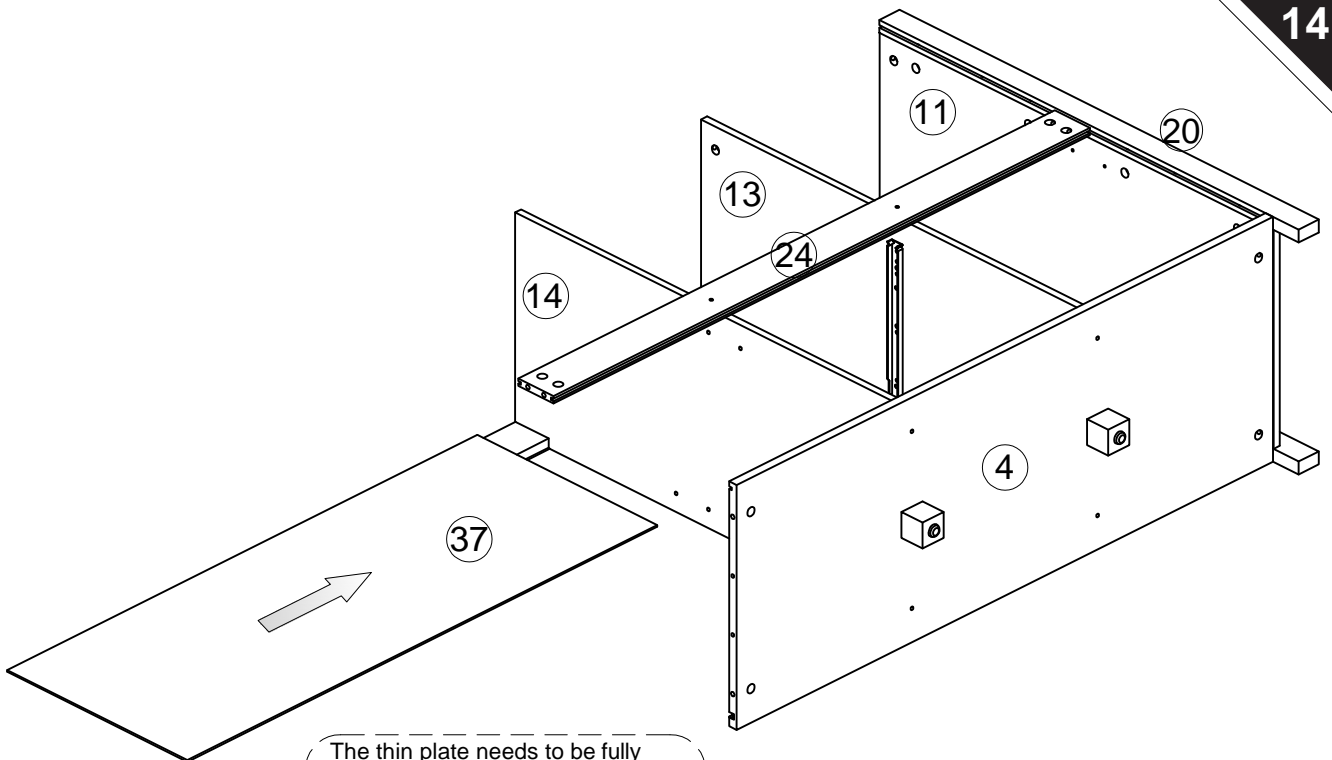

The thin plate needs to be fully inserted into the groove. If the insertion is not smooth, you can try pressing from the front or the back to make adjustments until the thin plate is fully inserted into the groove.

The thin plate needs to be fully inserted into the groove. If the insertion is not smooth, you can try pressing from the front or the back to make adjustments until the thin plate is fully inserted into the groove.

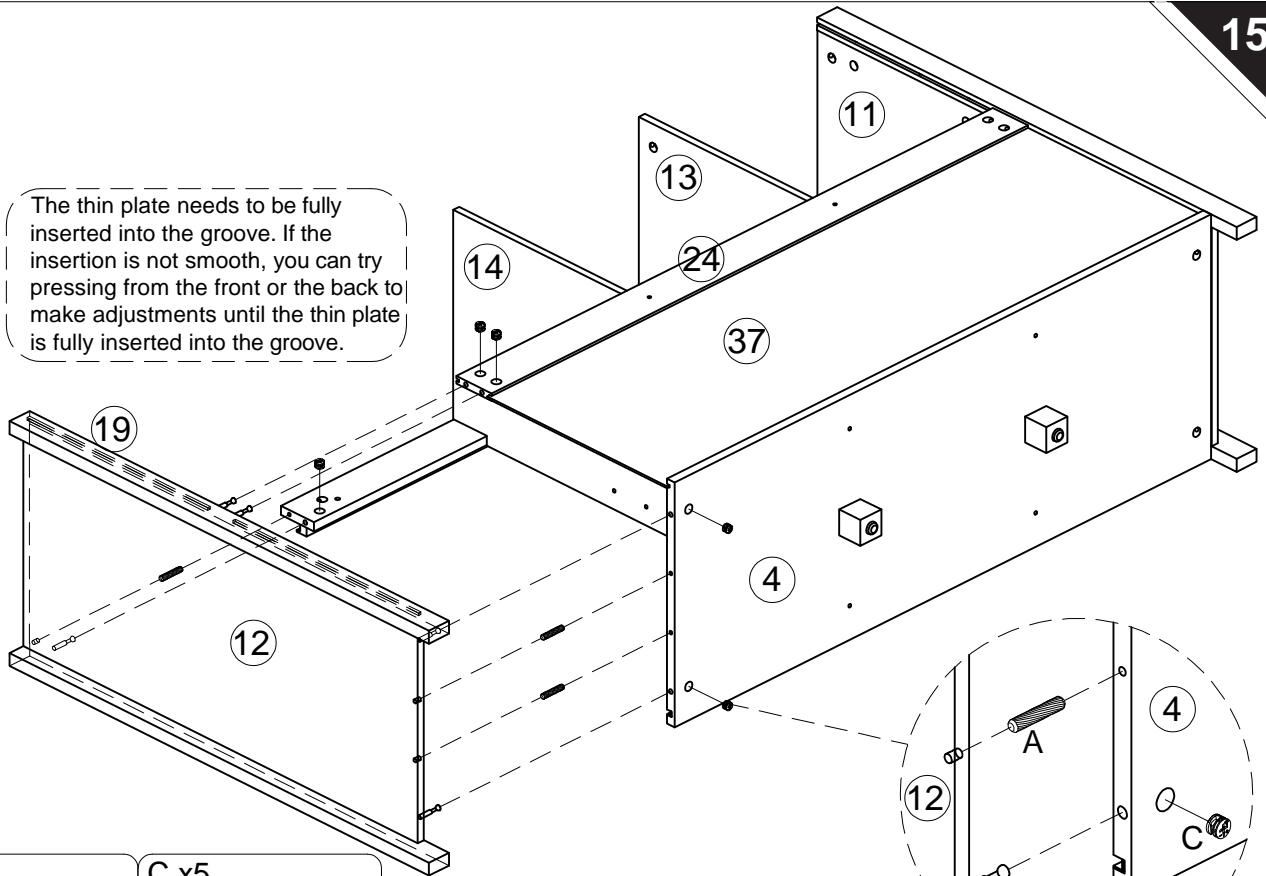

A x3



C x5

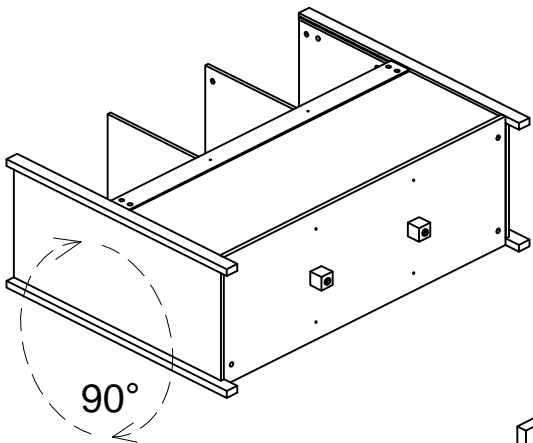
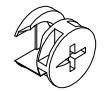

The thin plate needs to be fully inserted into the groove. If the insertion is not smooth, you can try pressing from the front or the back to make adjustments until the thin plate is fully inserted into the groove.

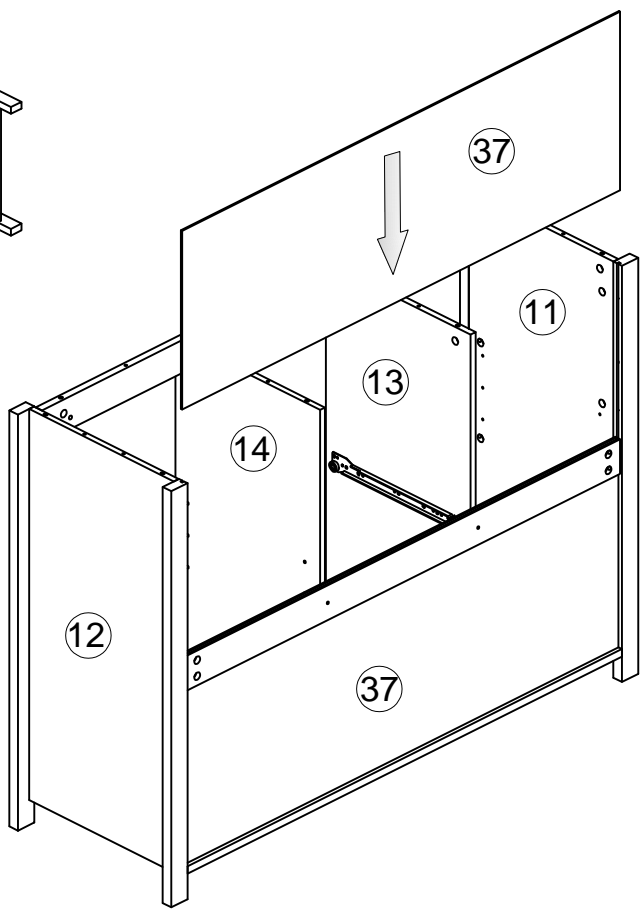

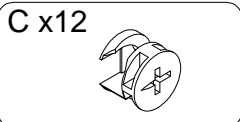
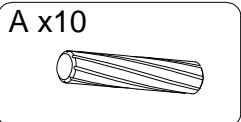
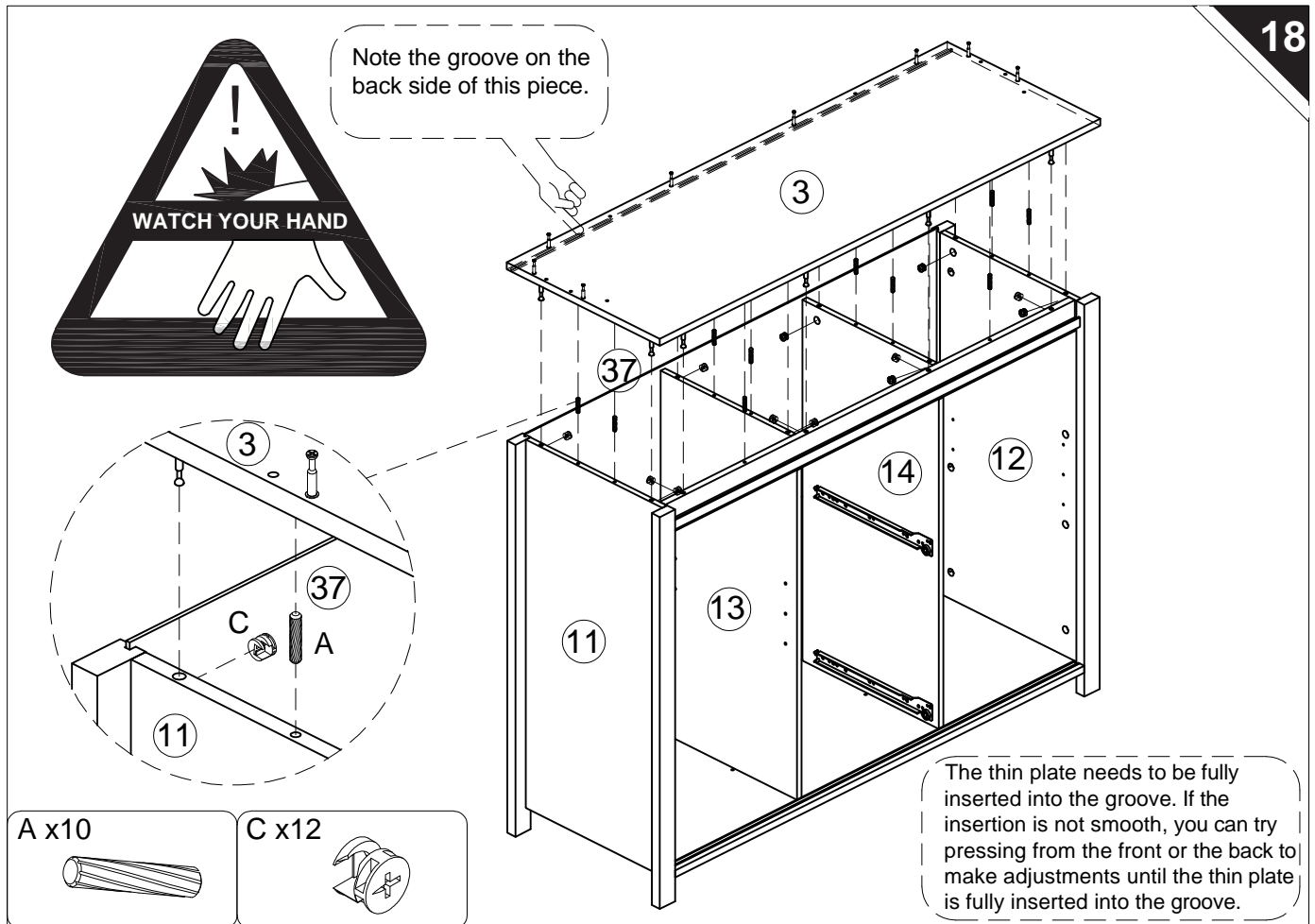
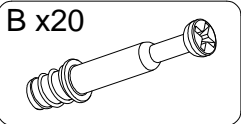
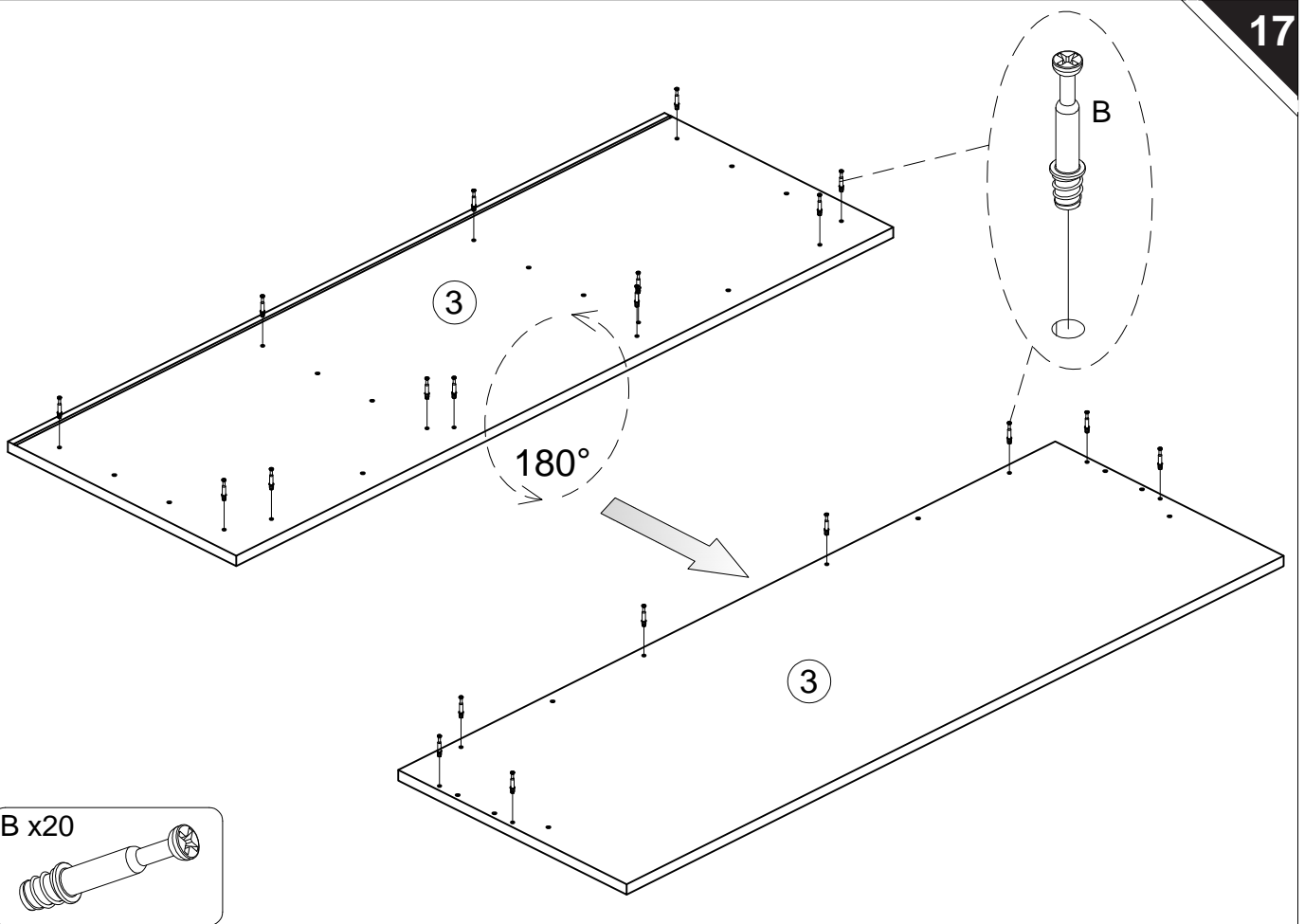

The thin plate needs to be fully inserted into the groove. If the insertion is not smooth, you can try pressing from the front or the back to make adjustments until the thin plate is fully inserted into the groove.

# X 2

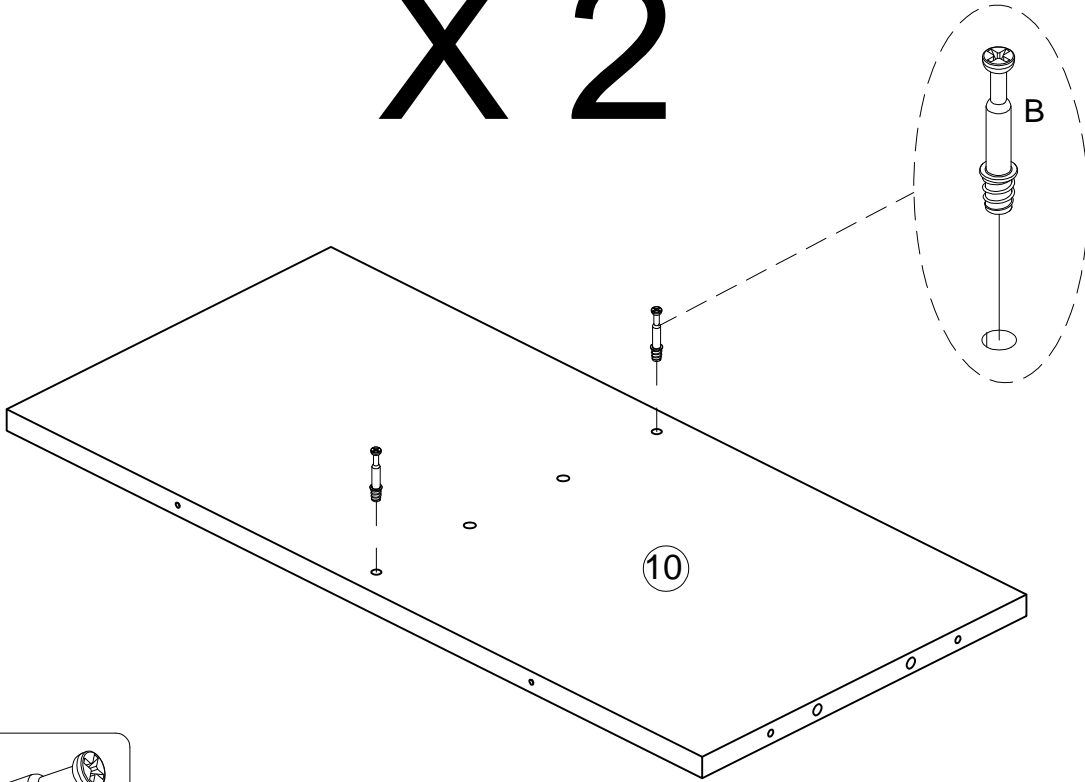

B x4

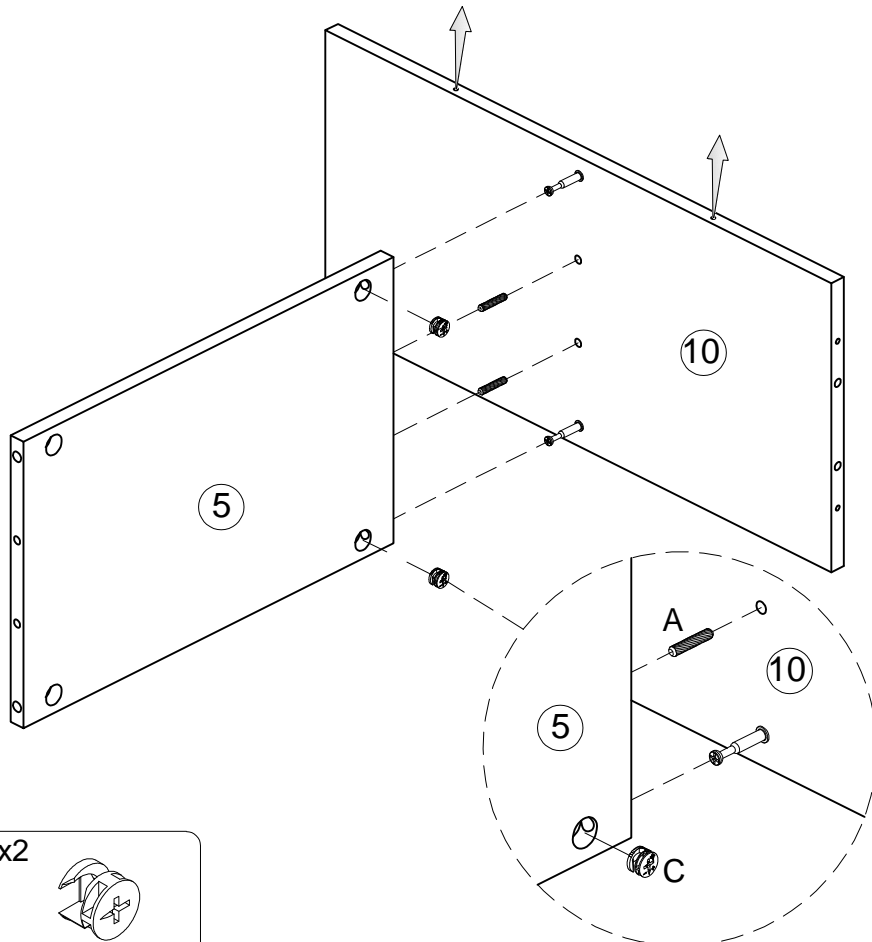
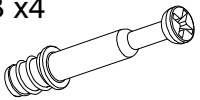

A x2



C x2



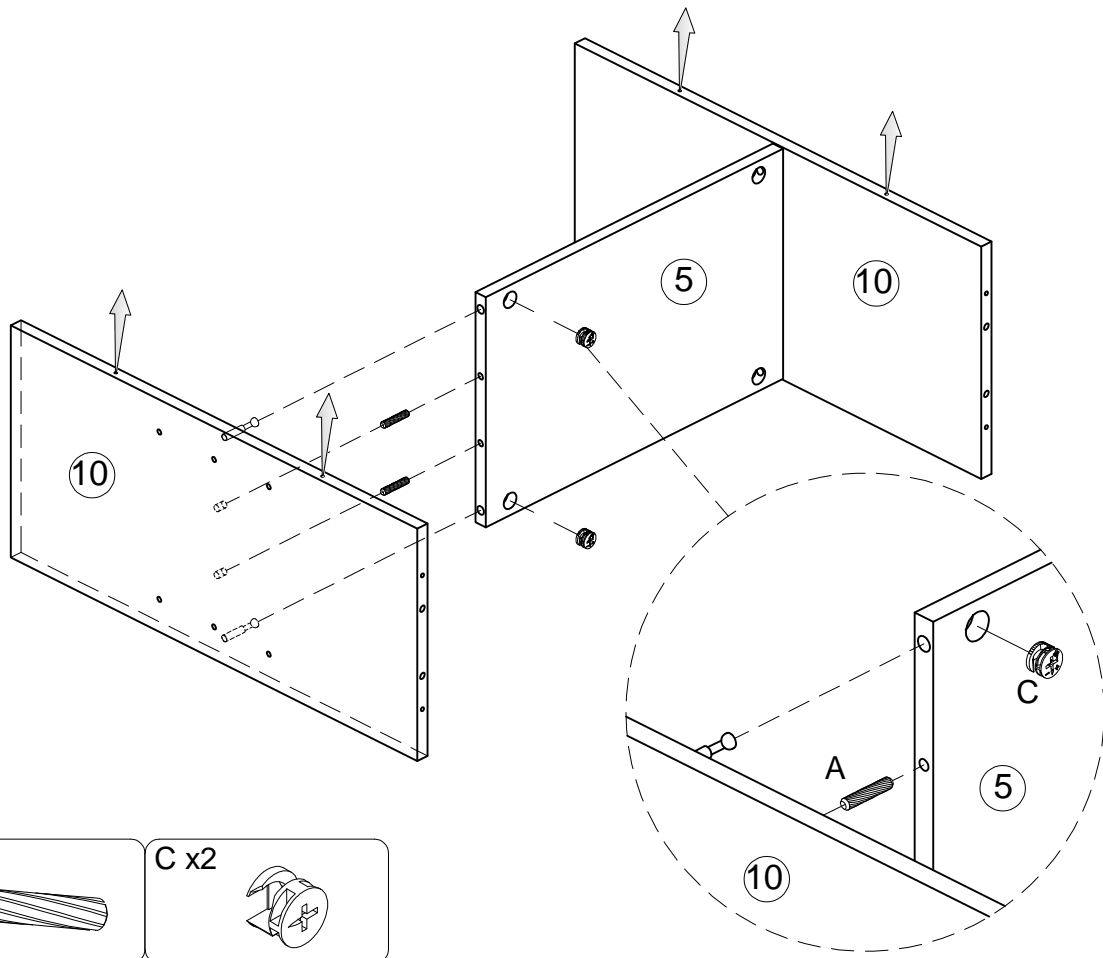

A x2

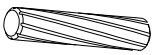

C x2

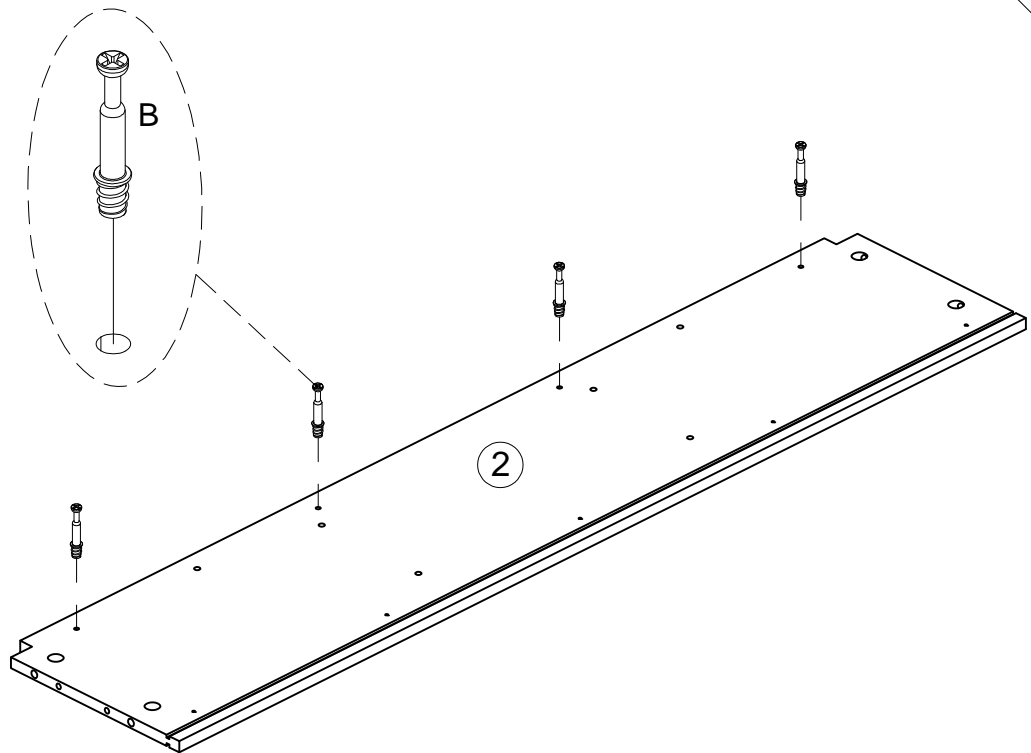

B x4

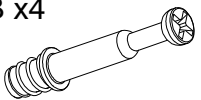

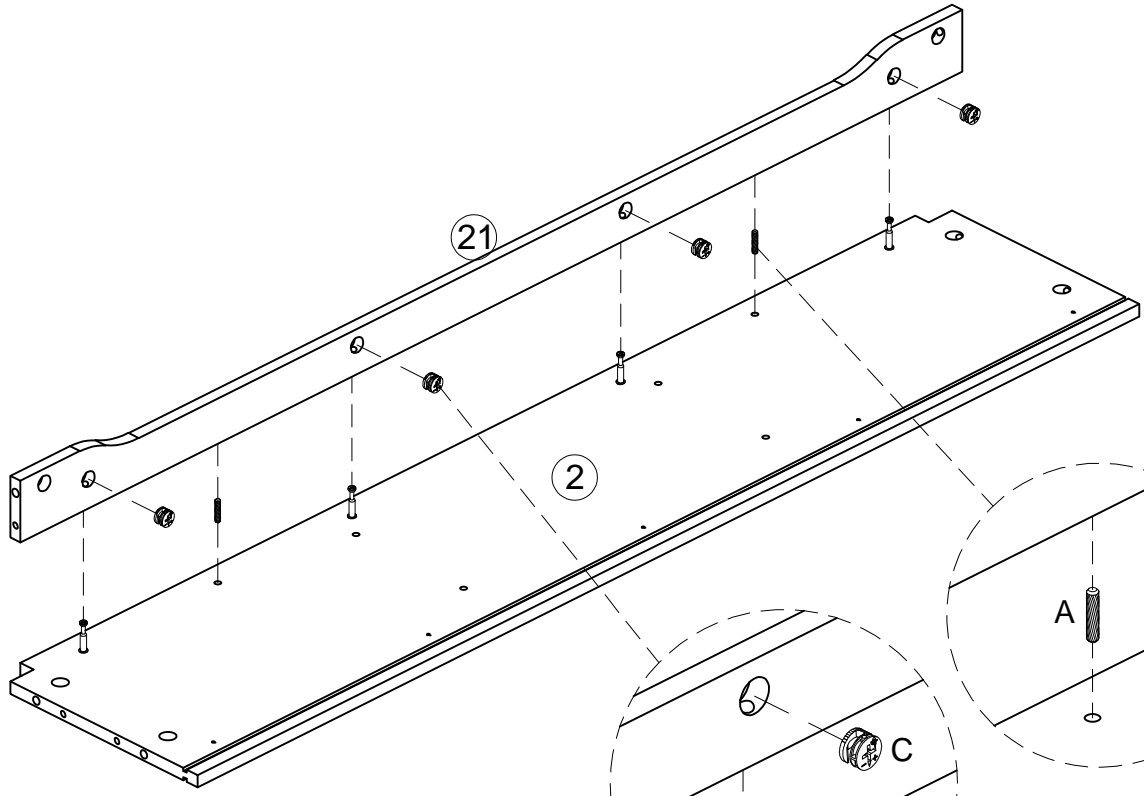

A x2



C x4

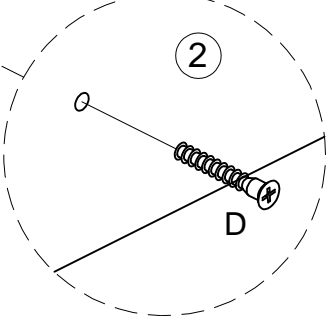
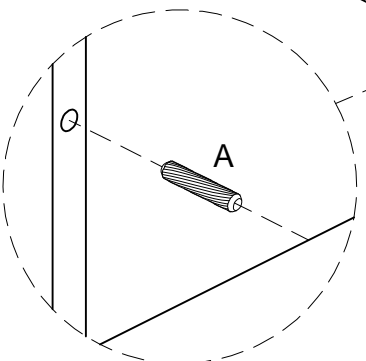
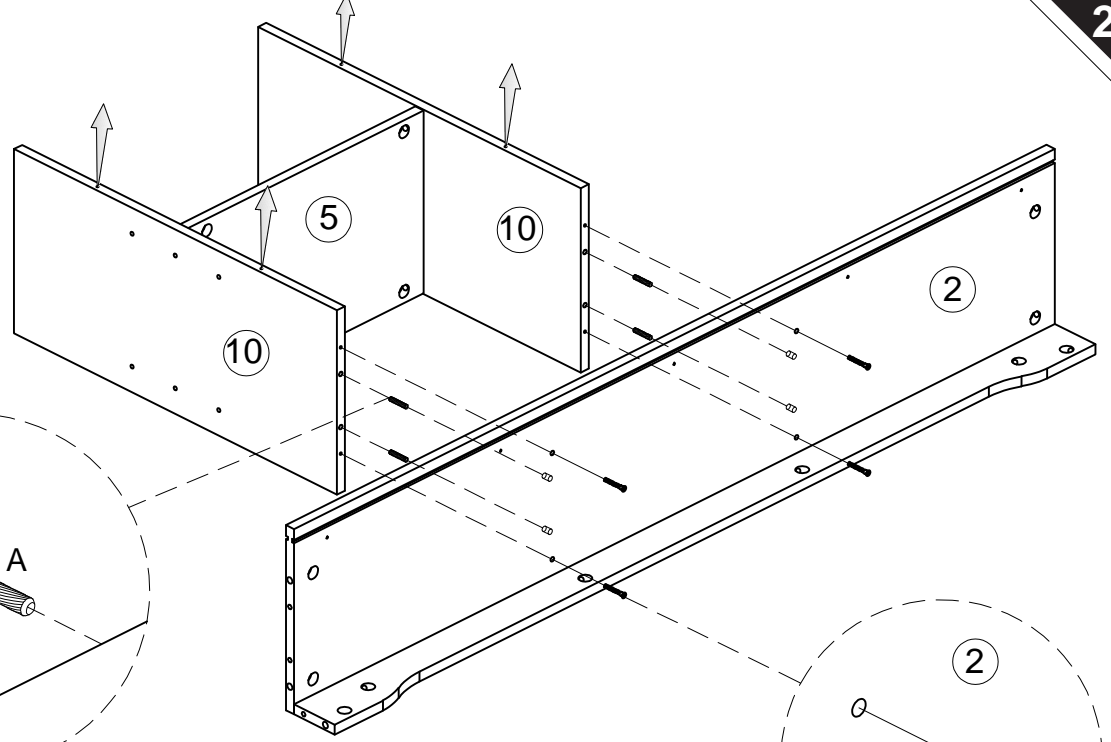
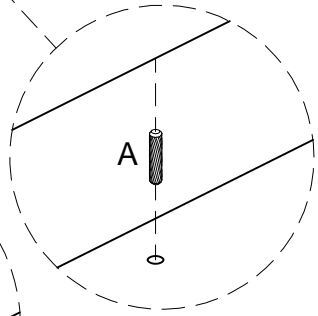
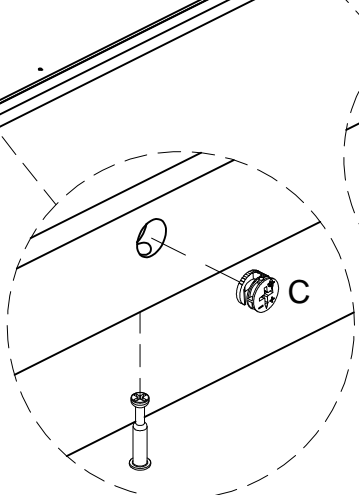
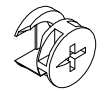

A x4





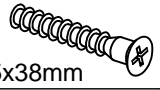

D x4

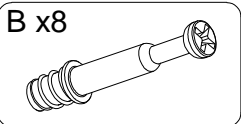
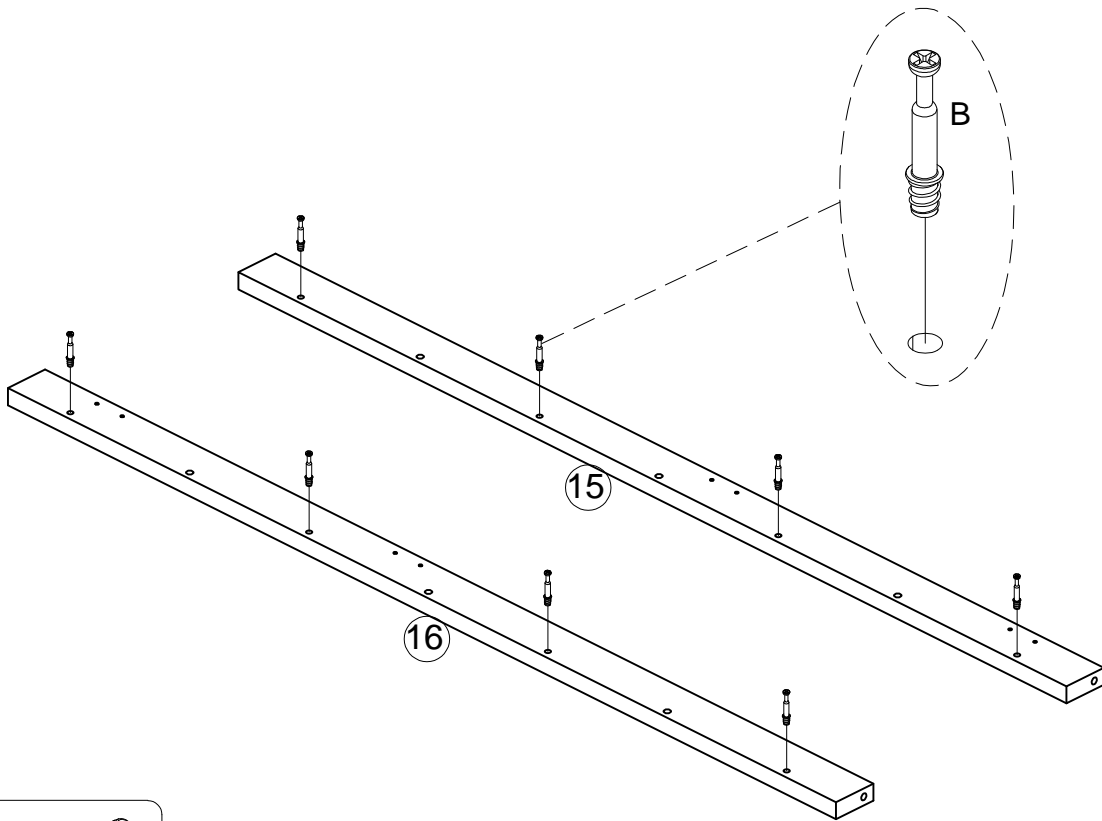
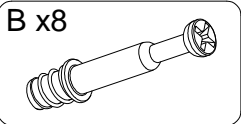
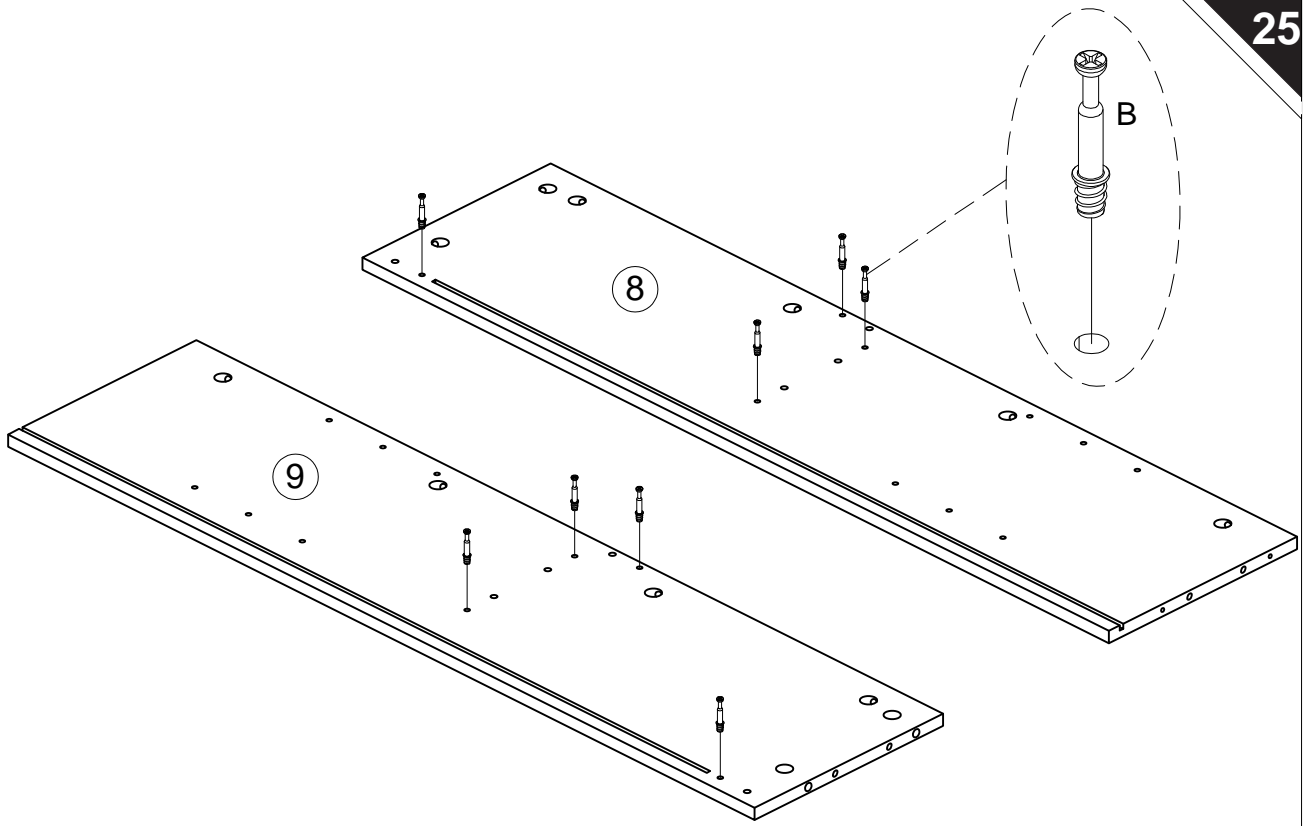

Ø5x38mm



P		Q		T		W	
X		✓		X		X	
Ø6x3x10		Ø6x3x12		Ø8x4x14		Ø6x3x16	

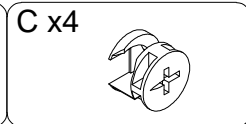
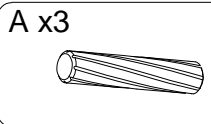
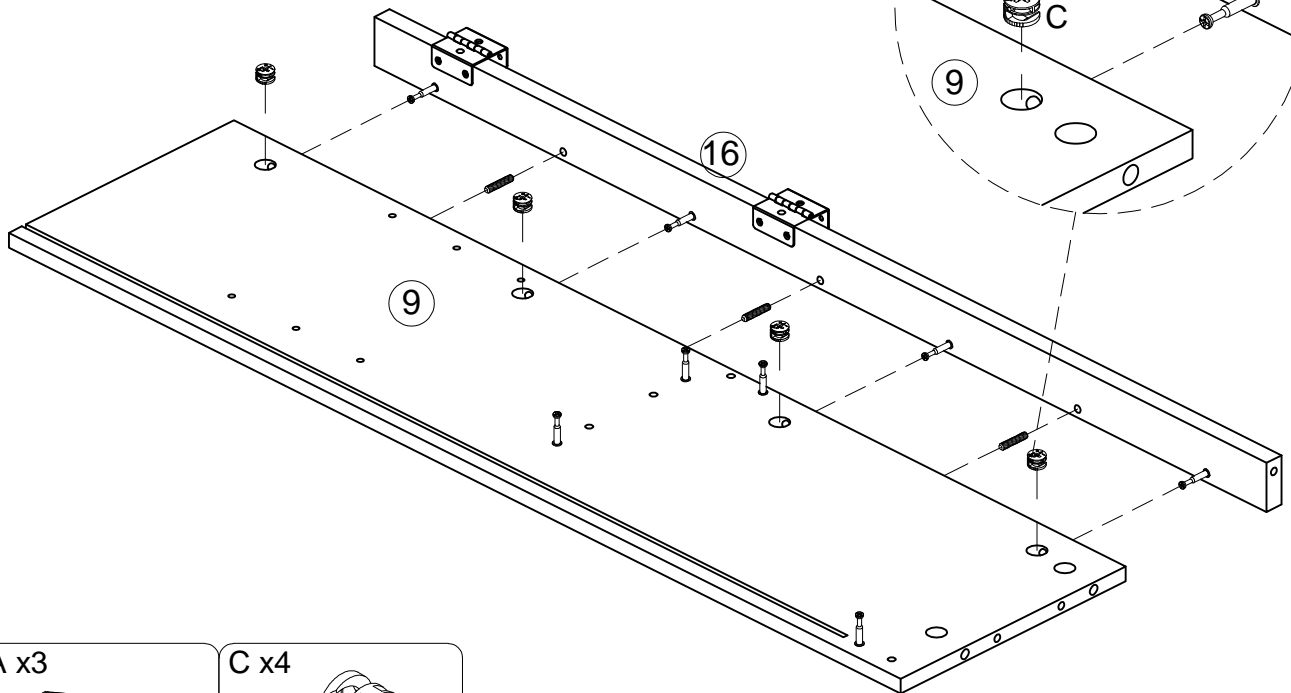
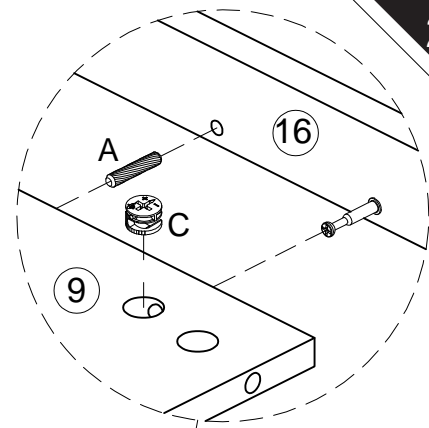
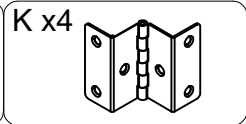
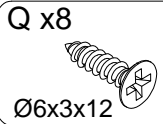
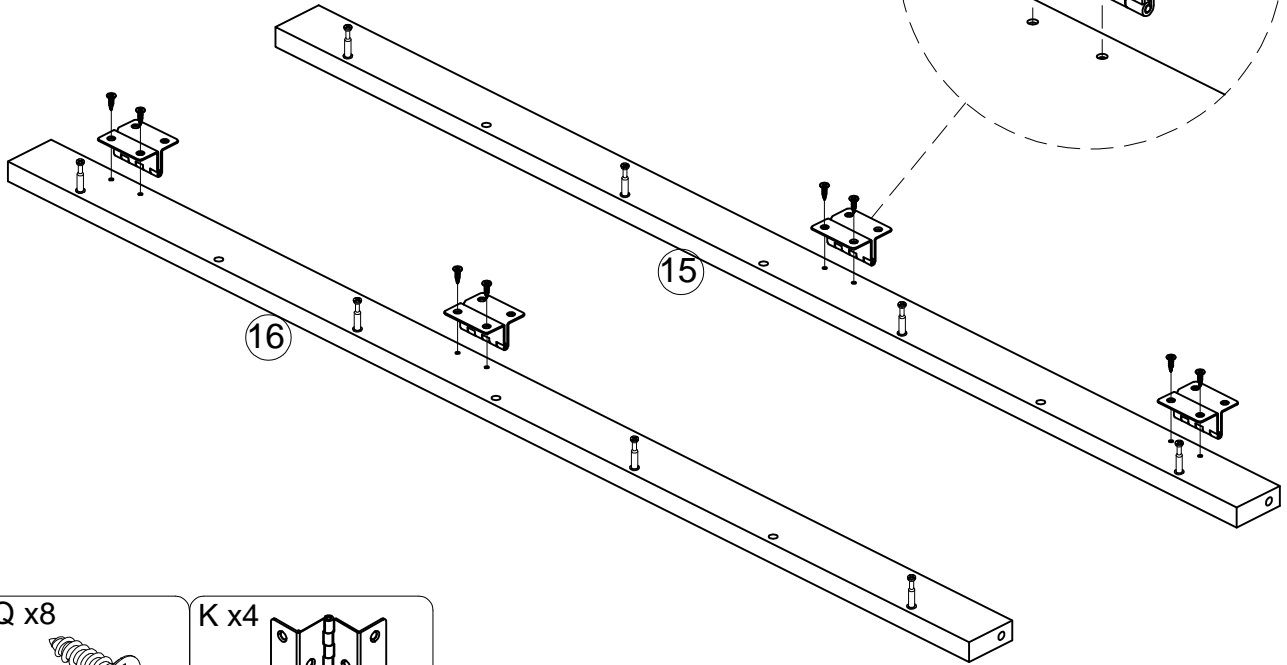
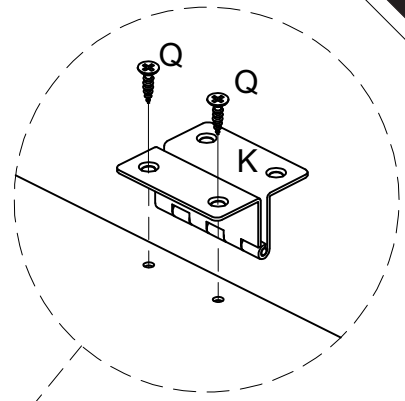

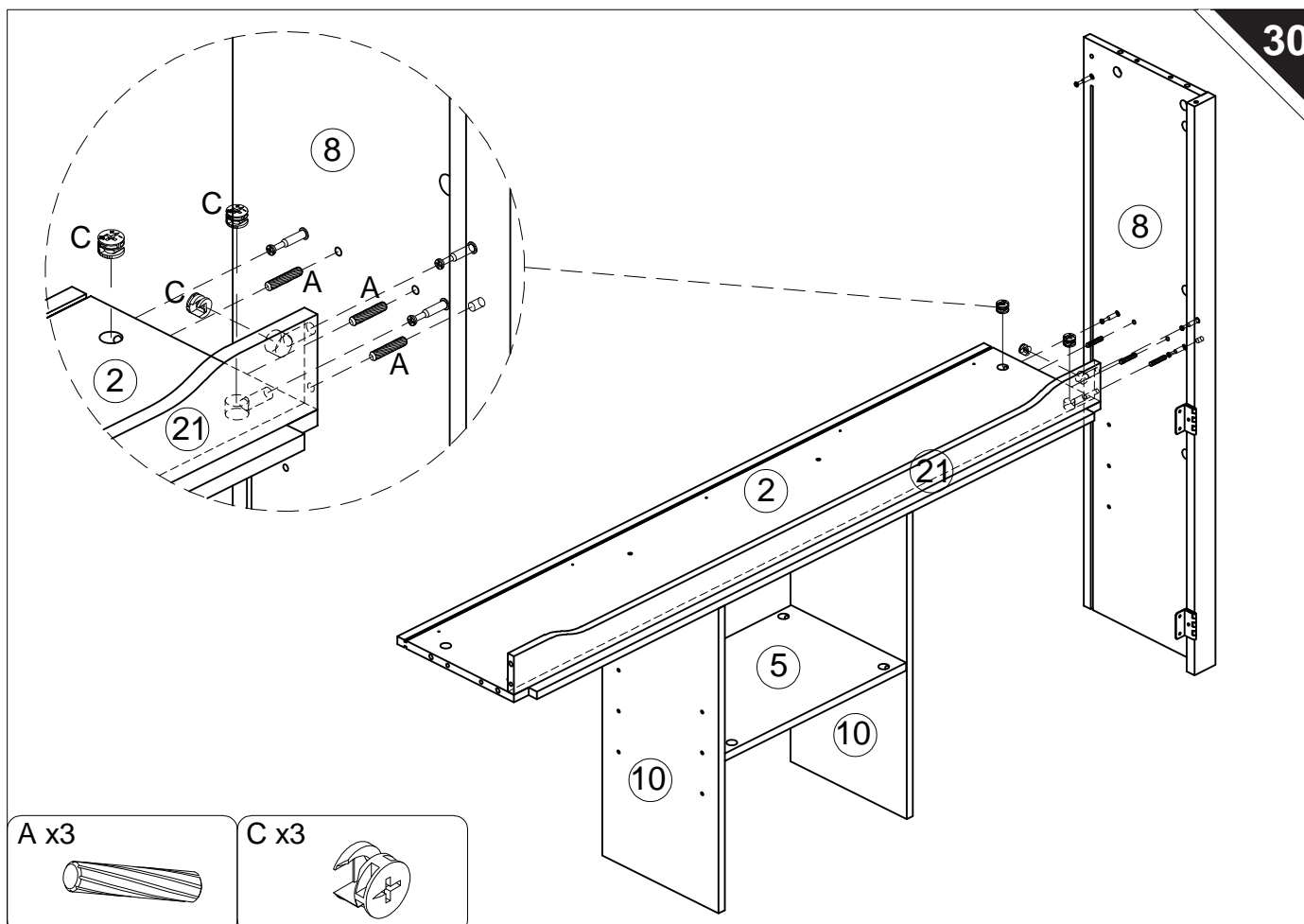
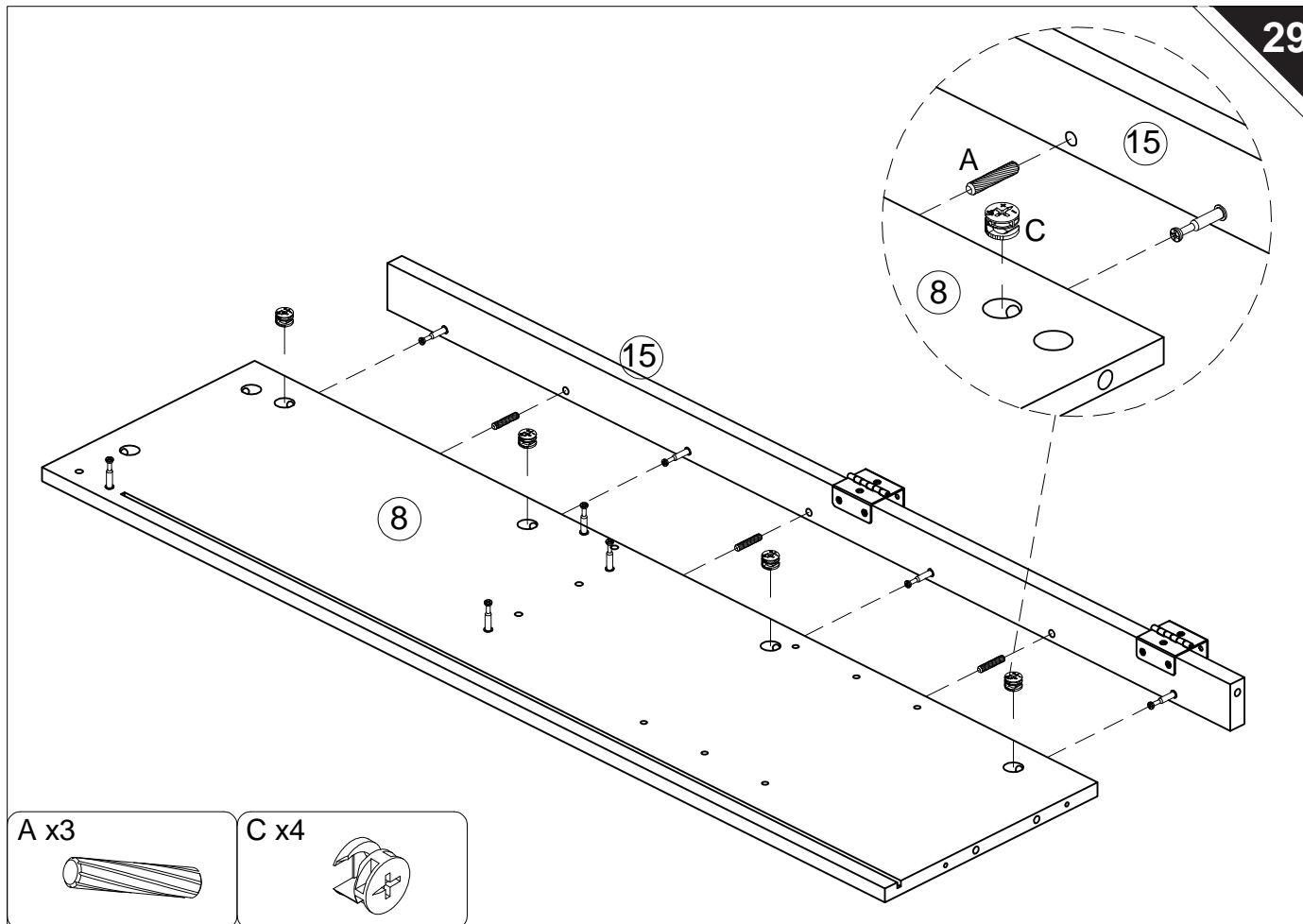

The thin plate needs to be fully inserted into the groove. If the insertion is not smooth, you can try pressing from the front or the back to make adjustments until the thin plate is fully inserted into the groove.

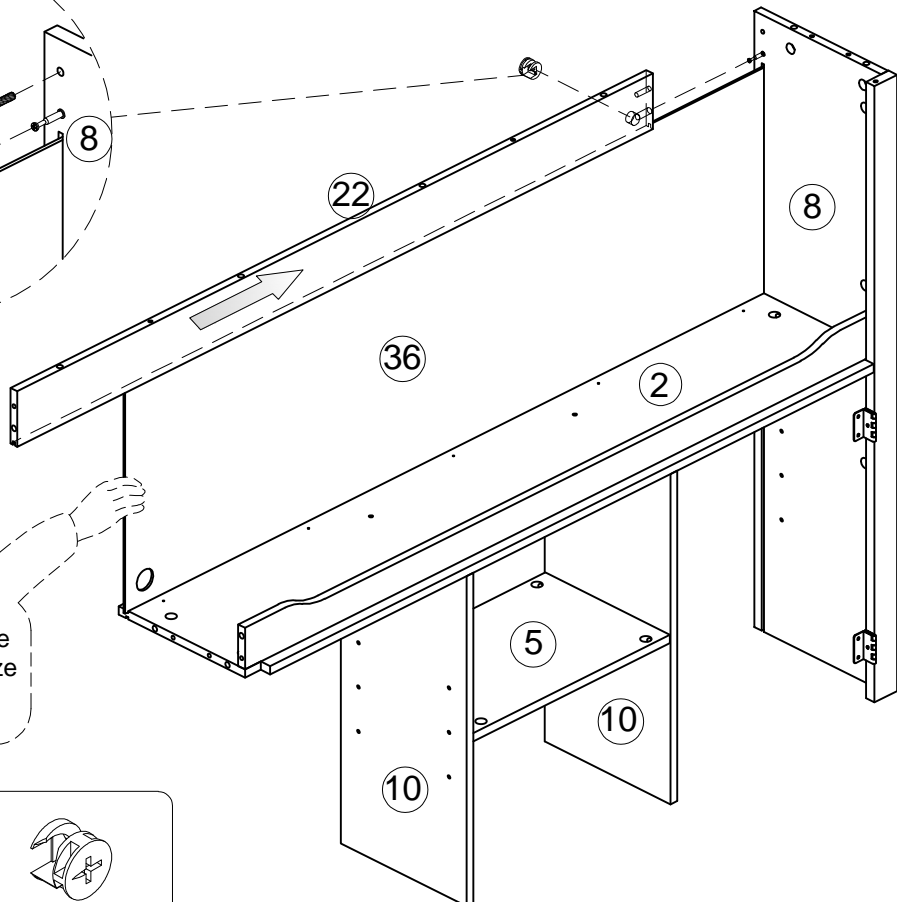
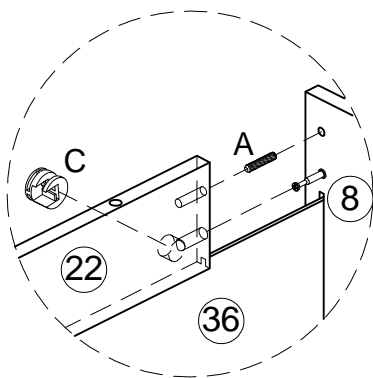
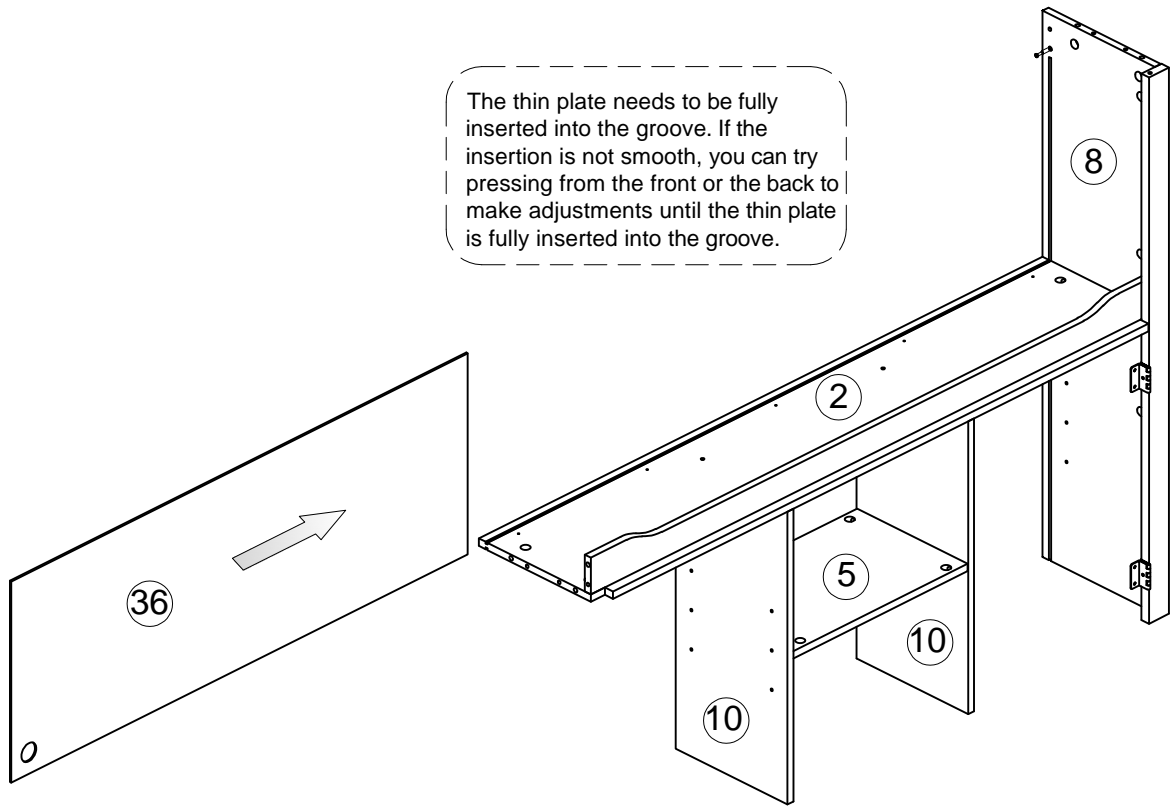

To prevent tipping, please use your hands to stabilize Part #36.

A x1



C x1



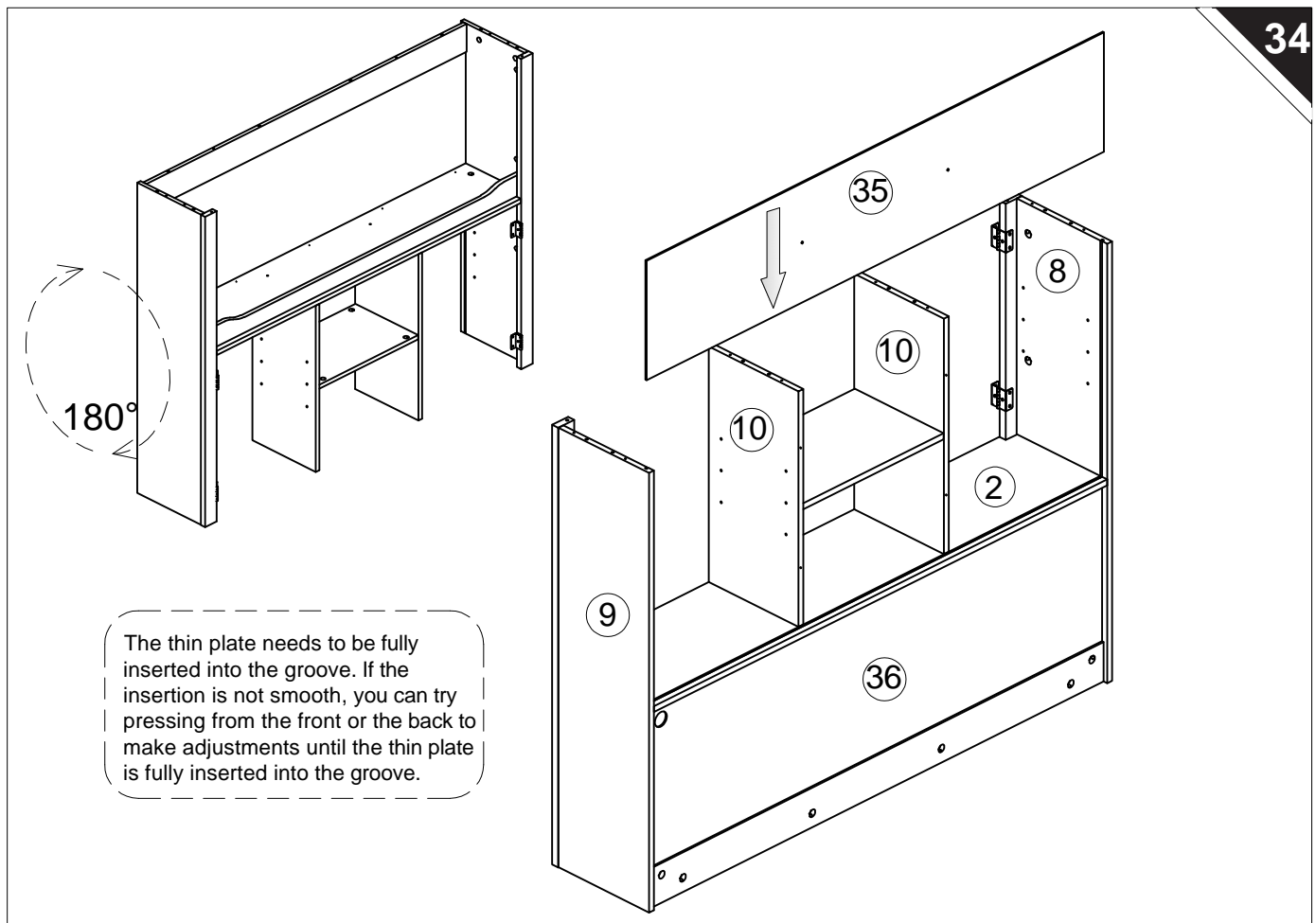
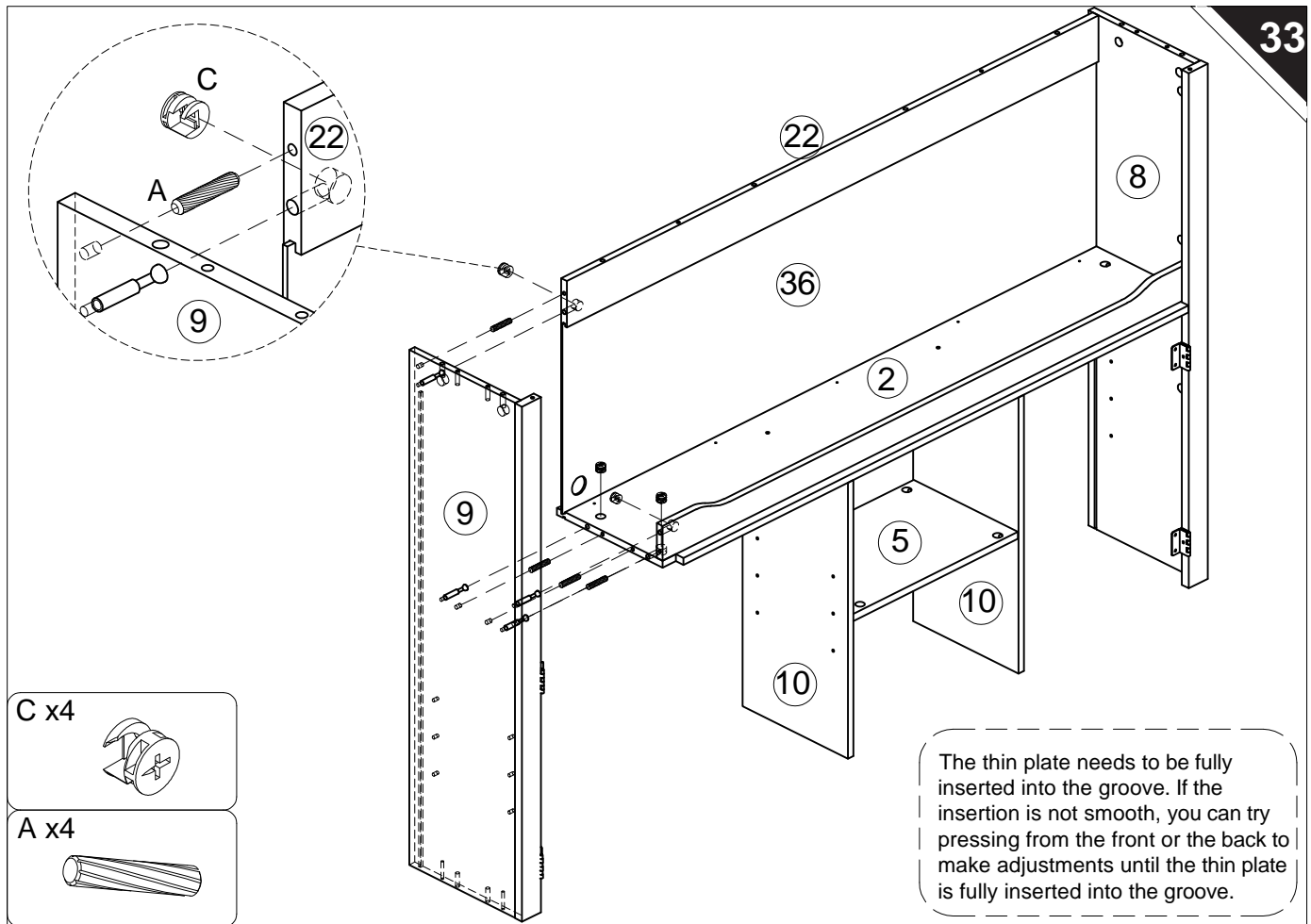

The thin plate needs to be fully inserted into the groove. If the insertion is not smooth, you can try pressing from the front or the back to make adjustments until the thin plate is fully inserted into the groove.

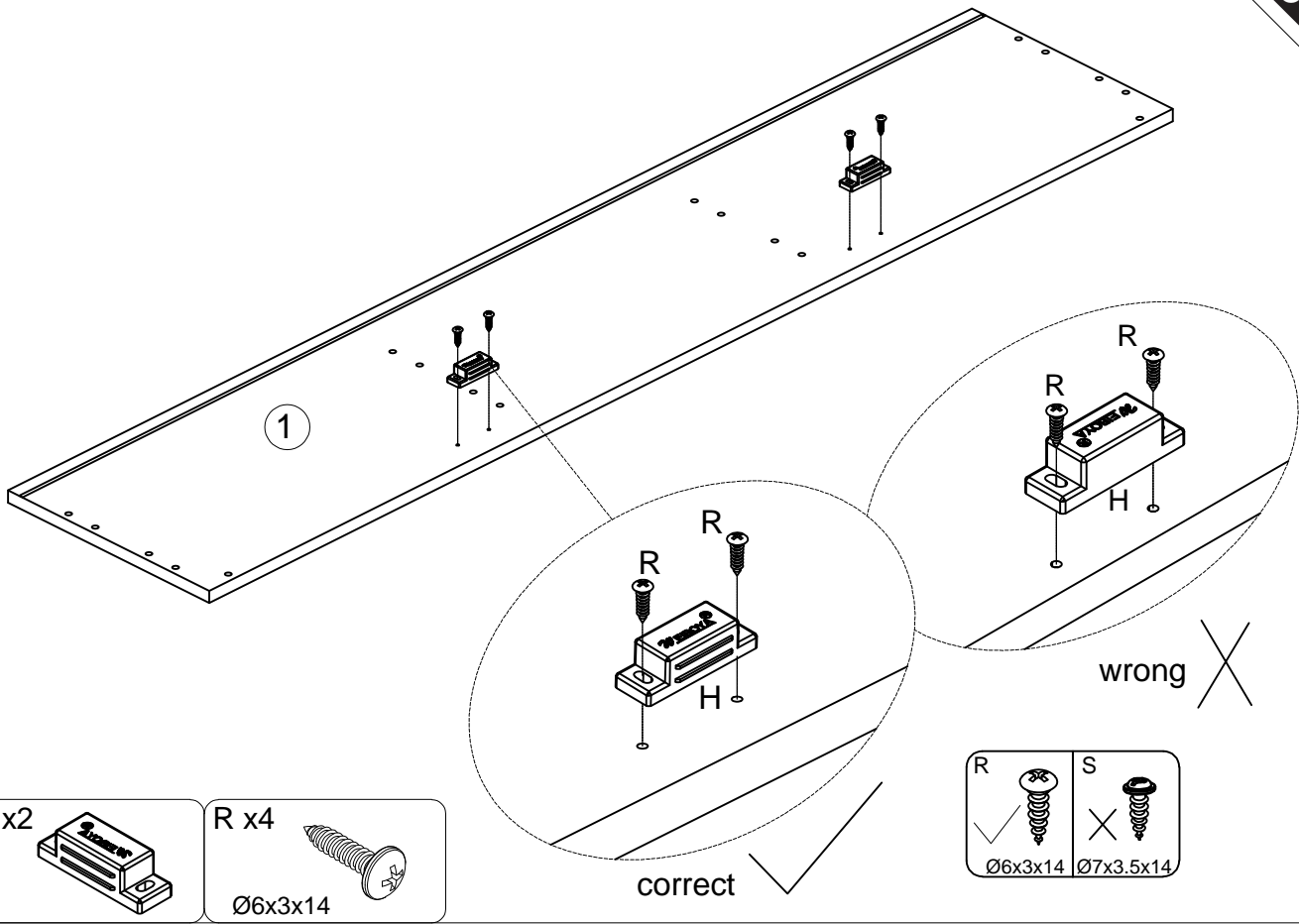
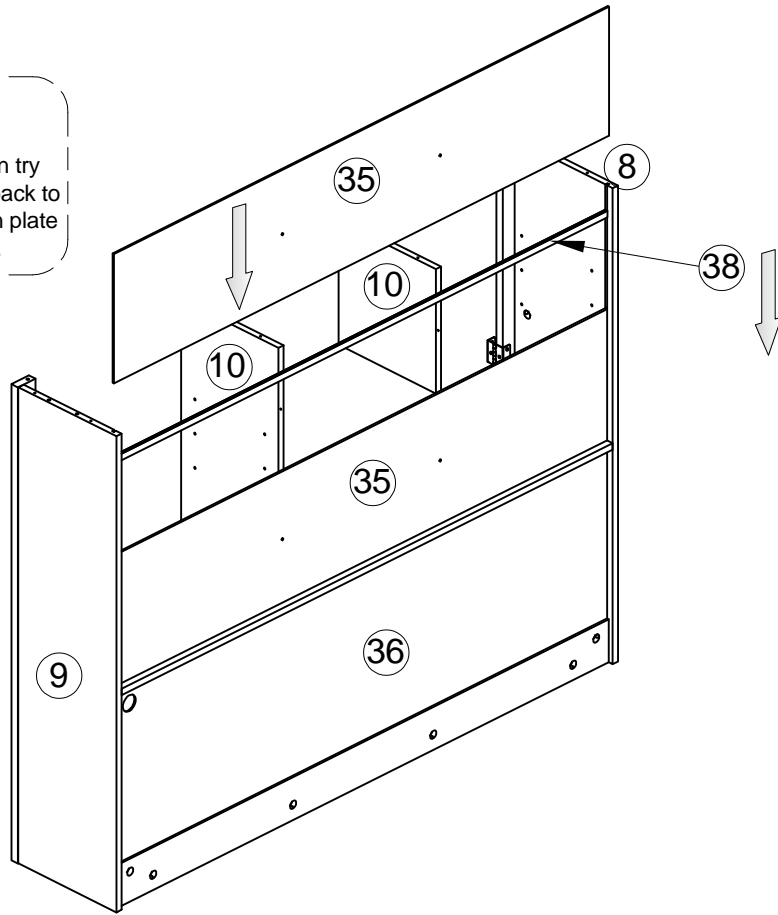

The thin plate needs to be fully inserted into the groove. If the insertion is not smooth, you can try pressing from the front or the back to make adjustments until the thin plate is fully inserted into the groove.

Pay attention to the position of the magnetic strip on the back.

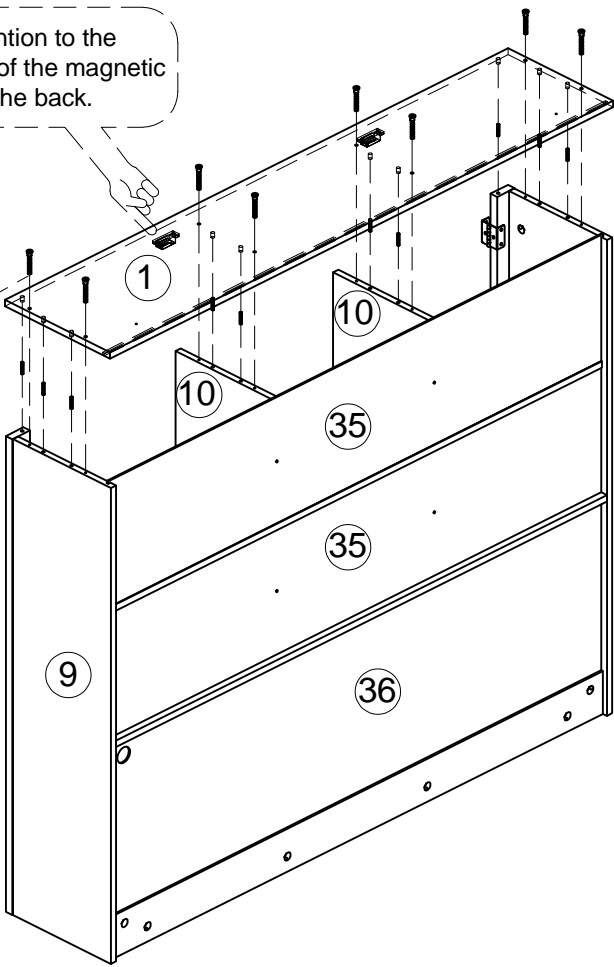
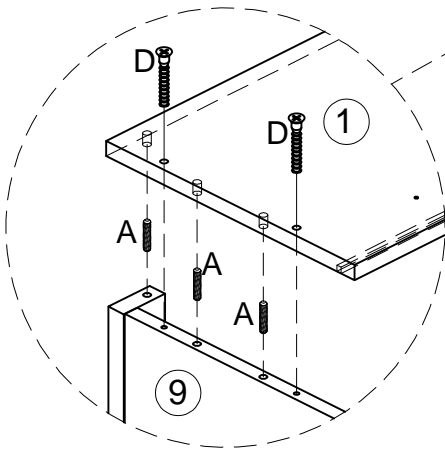

A x10



D x8



Ø5x38mm

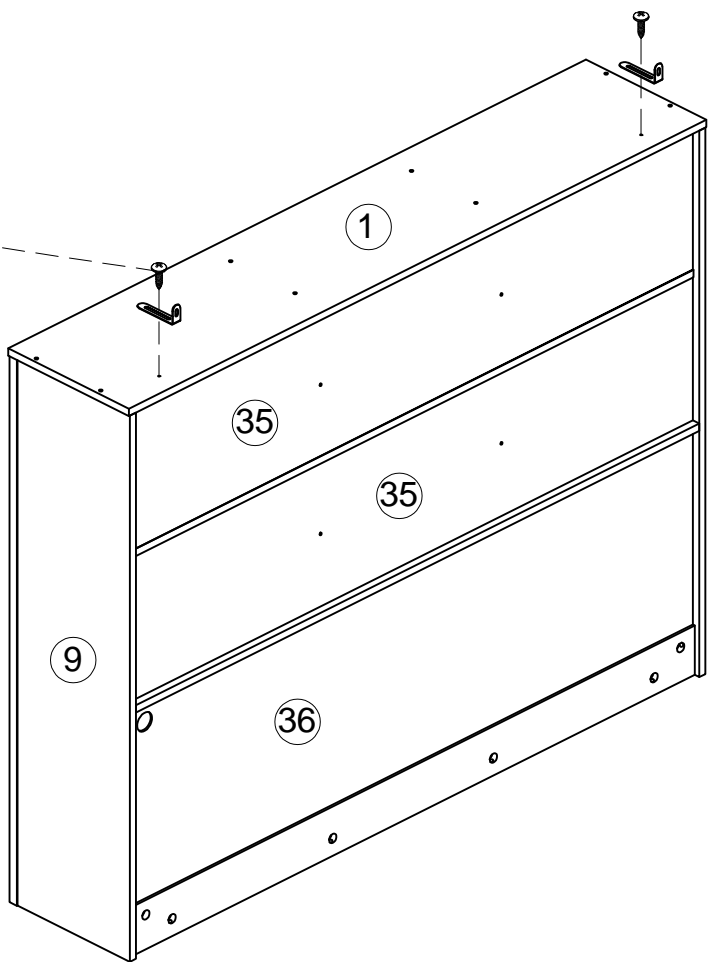
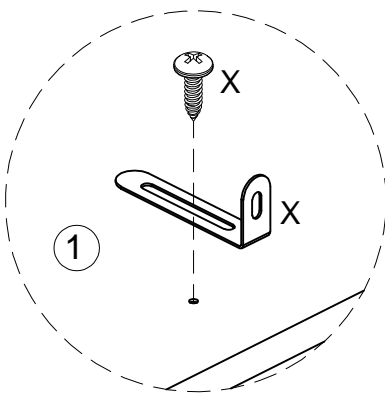

X x2



Ø8xØ4x12mm

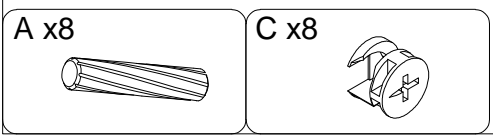
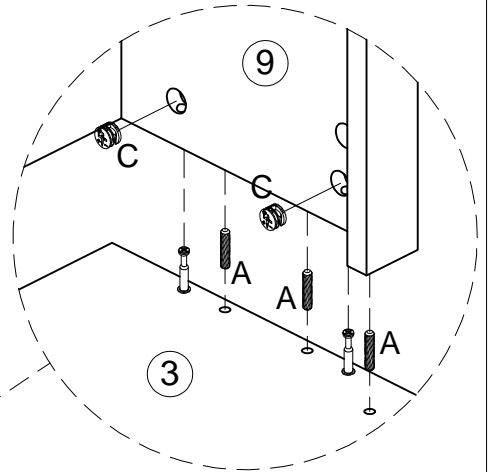
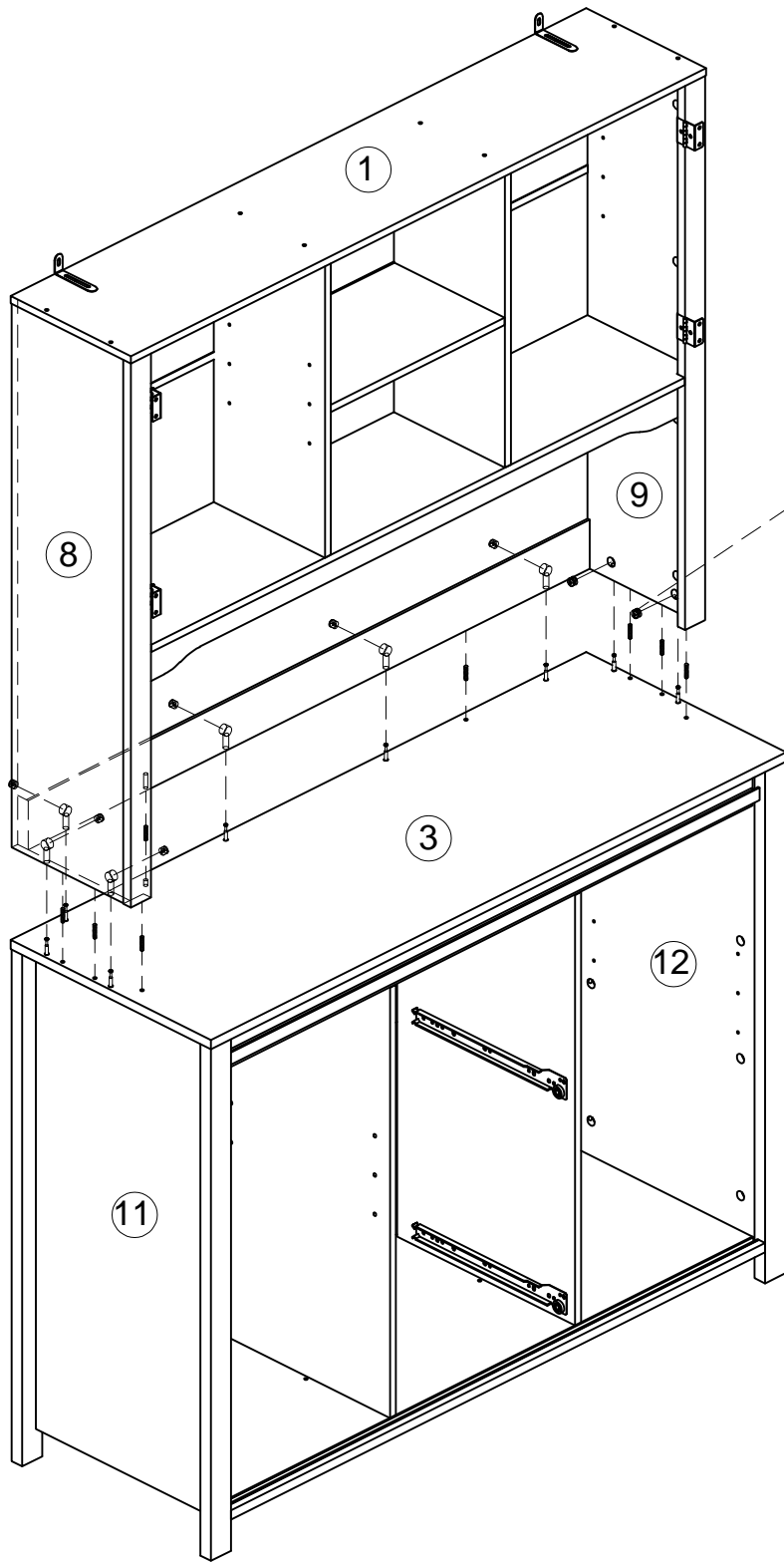

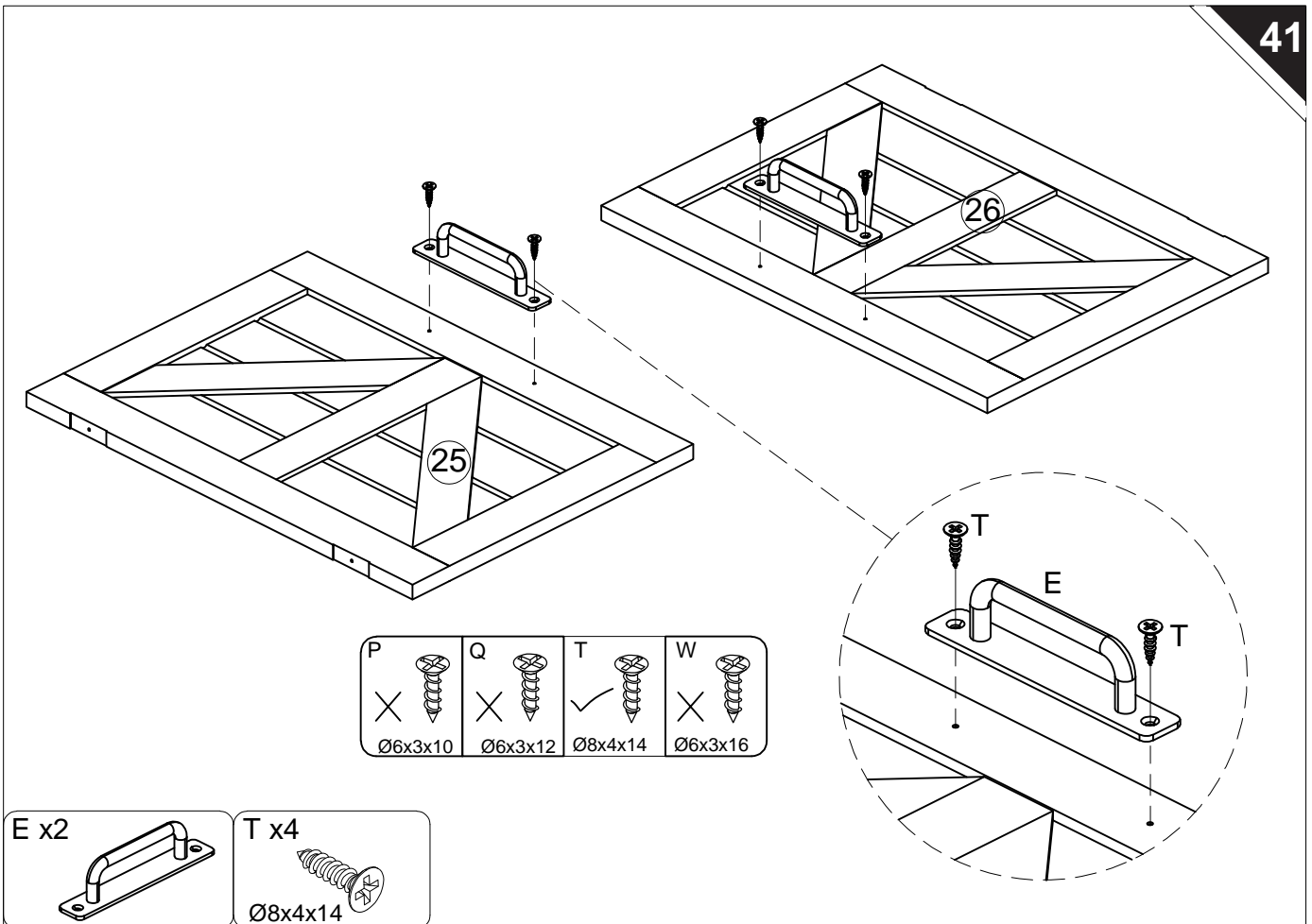
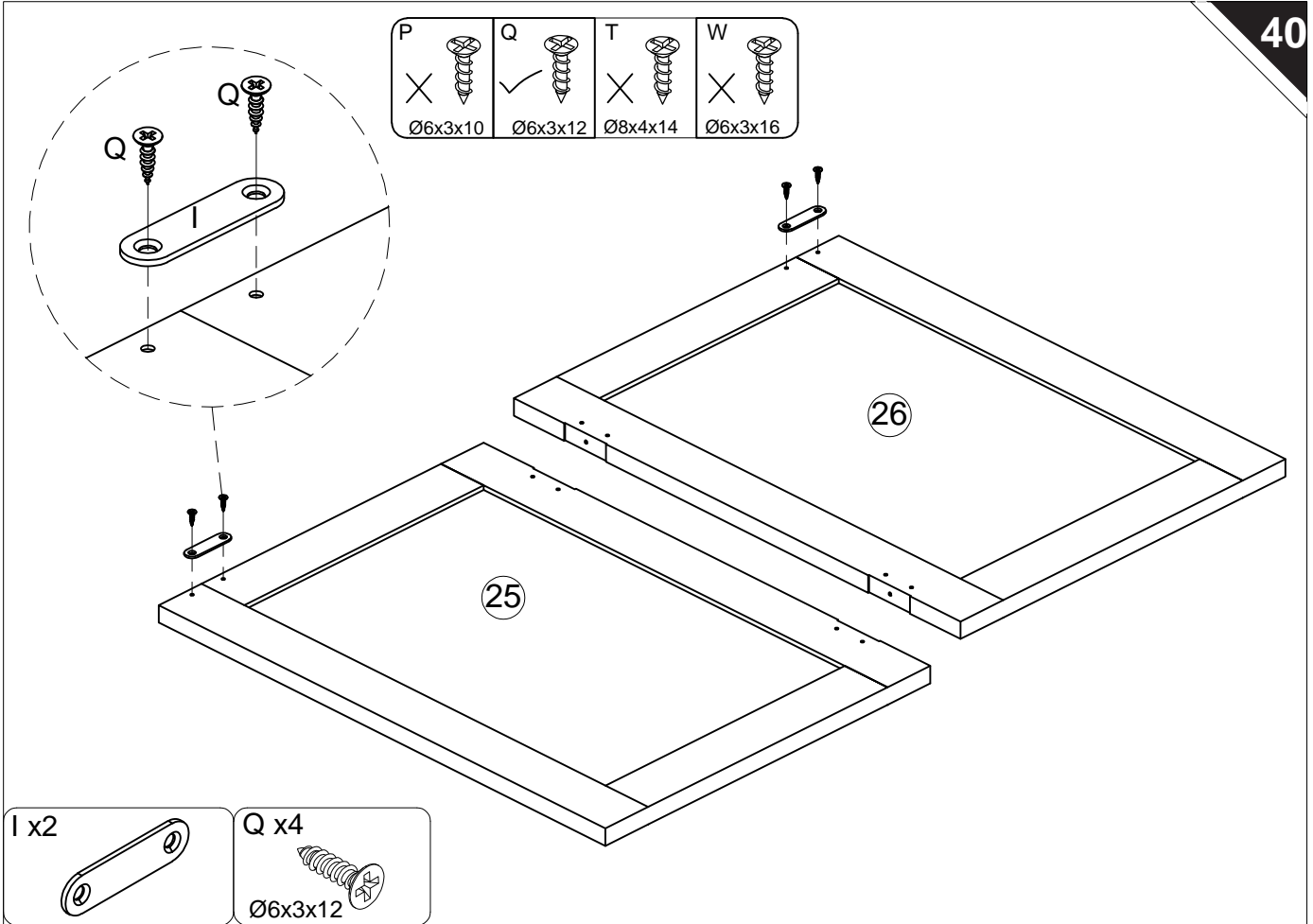

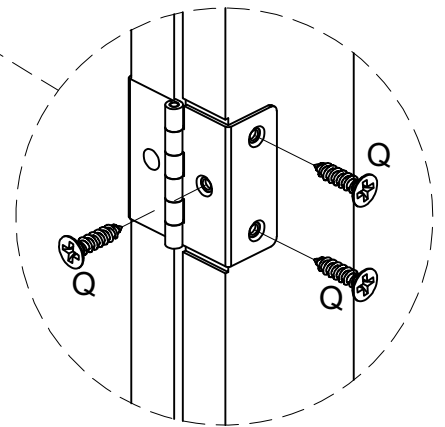
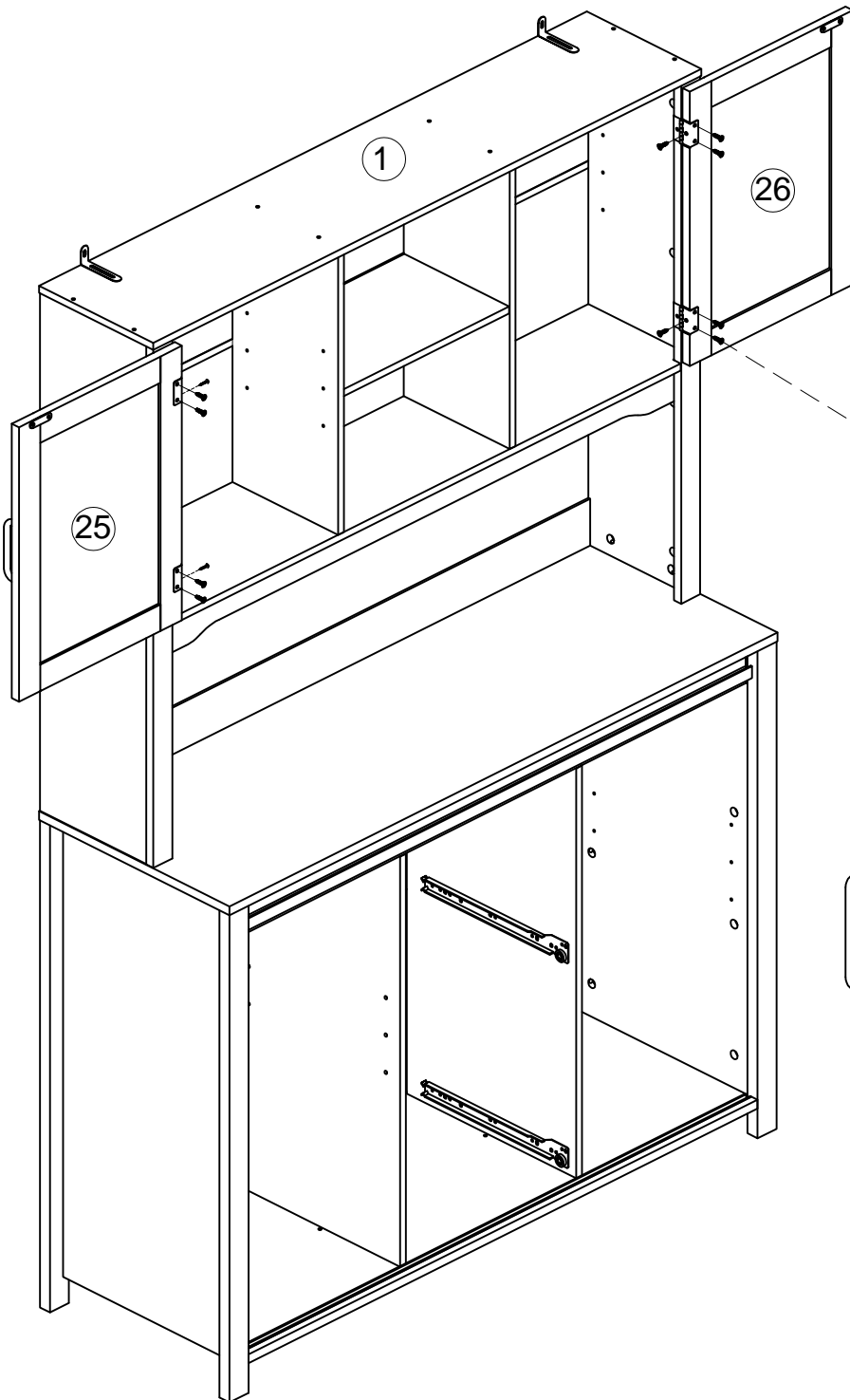

P	Q	T	W
<input checked="" type="checkbox"/>	<input checked="" type="checkbox"/>	<input checked="" type="checkbox"/>	<input checked="" type="checkbox"/>
Ø6x3x10	Ø6x3x12	Ø8x4x14	Ø6x3x16

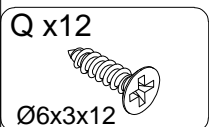

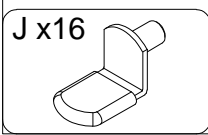
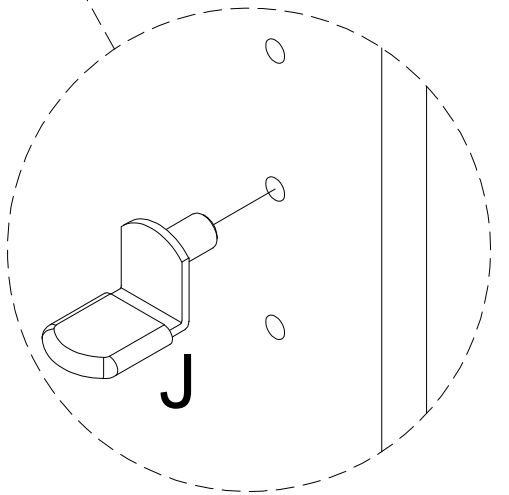
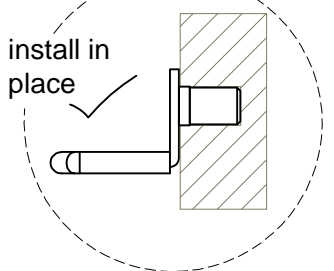
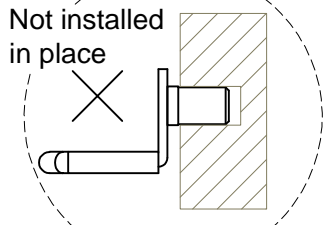
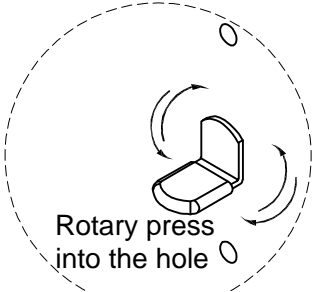
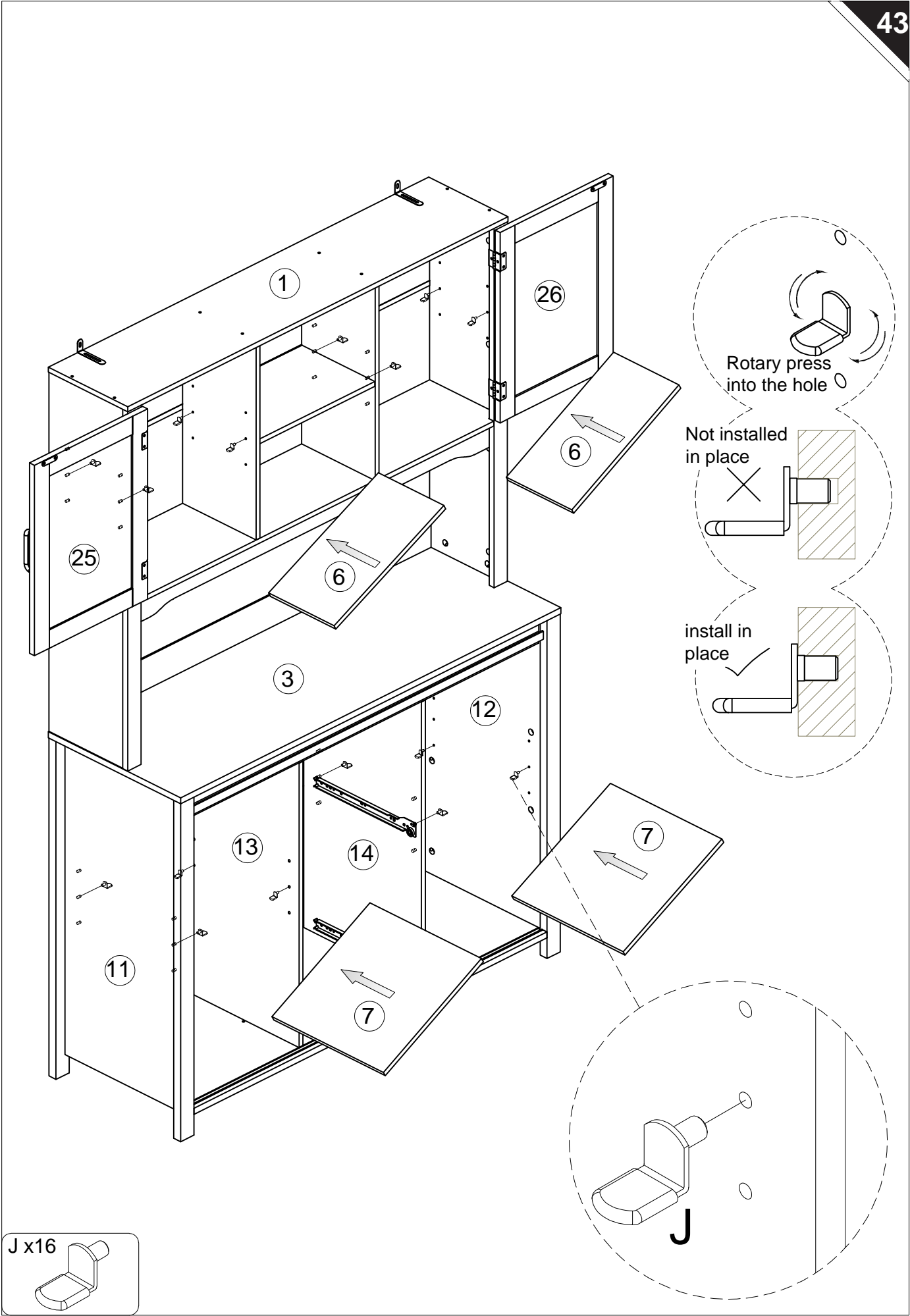

X 2

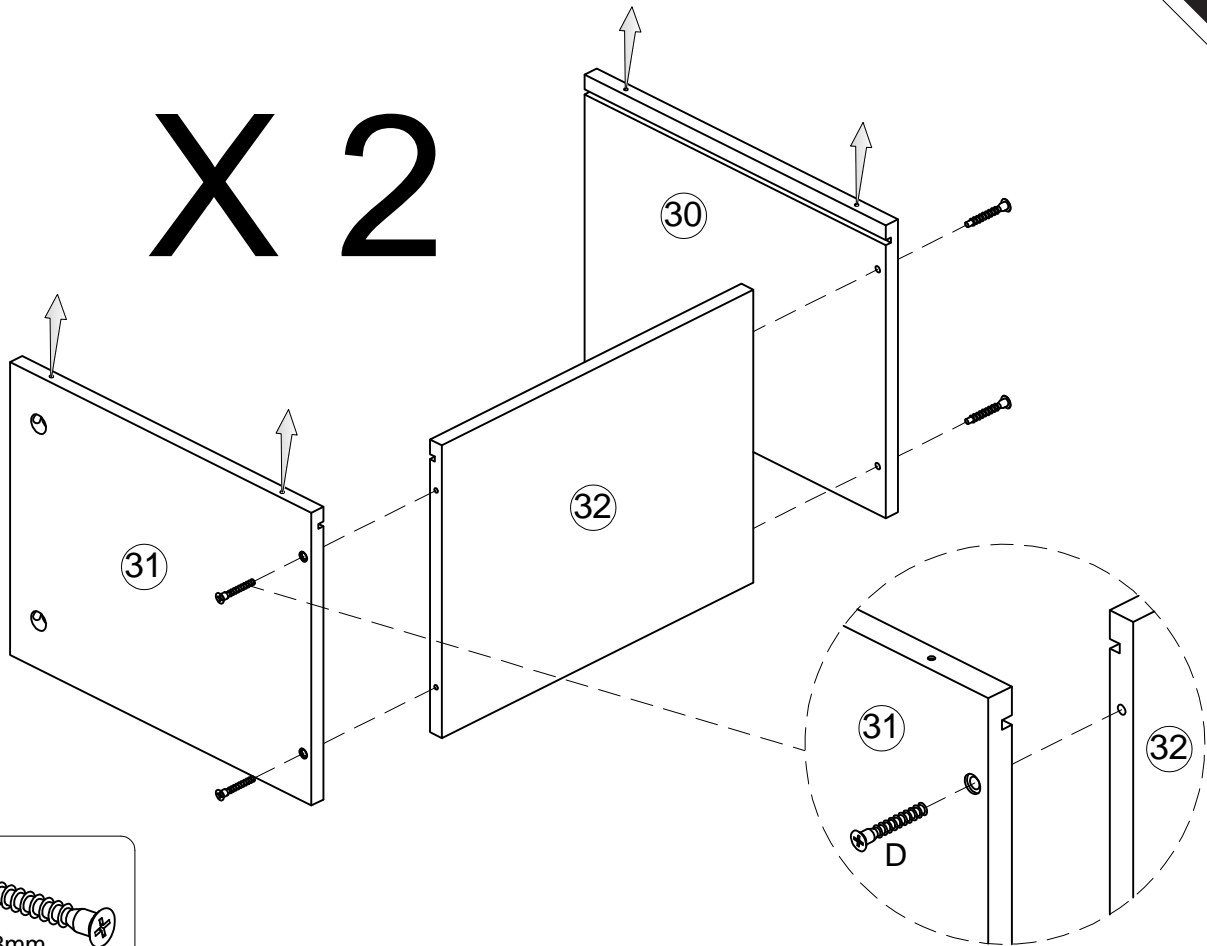

D x 8

Ø5x38mm



X 2

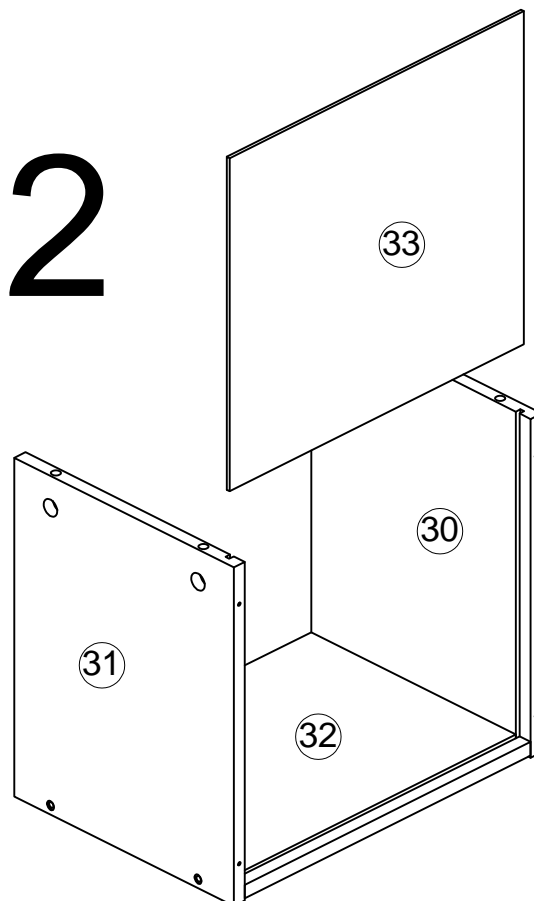

The thin plate needs to be fully inserted into the groove. If the insertion is not smooth, you can try pressing from the front or the back to make adjustments until the thin plate is fully inserted into the groove.

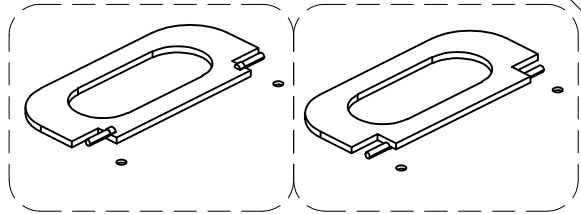
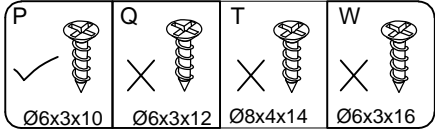

correct ✓

wrong ✗

Pay attention to the direction of the shaft column. The shaft column should be on the top.

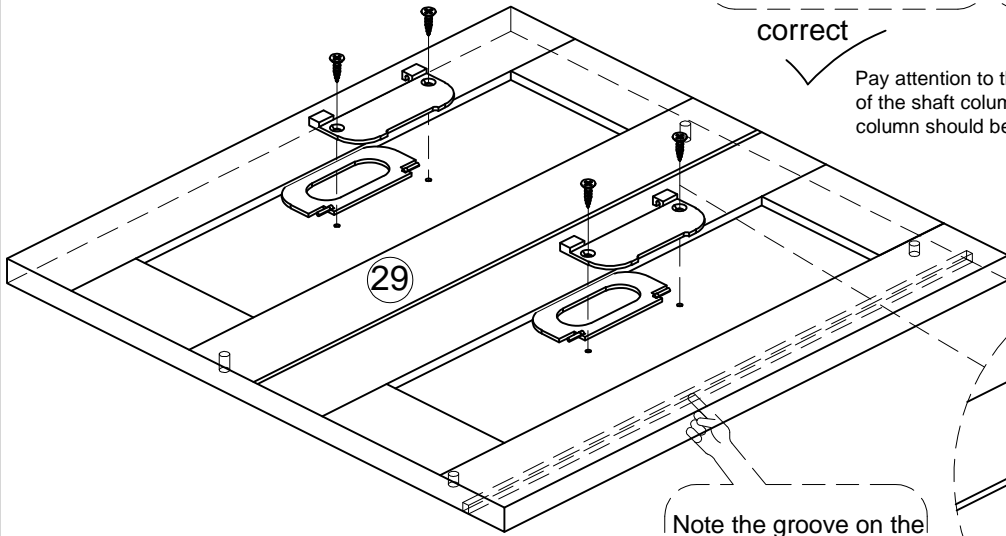

Note the groove on the back side of this piece.

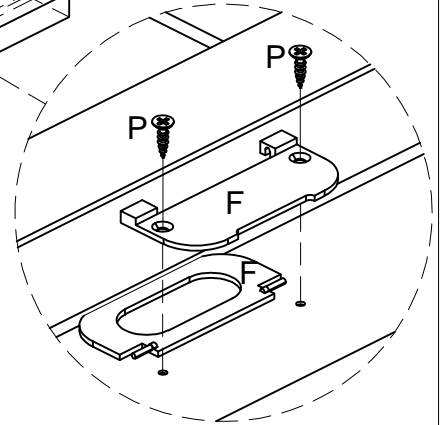

F x4



P x8



Ø6x3x10

# X 2

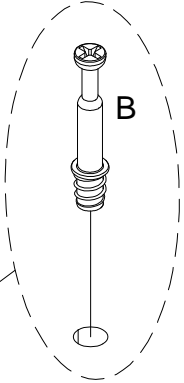
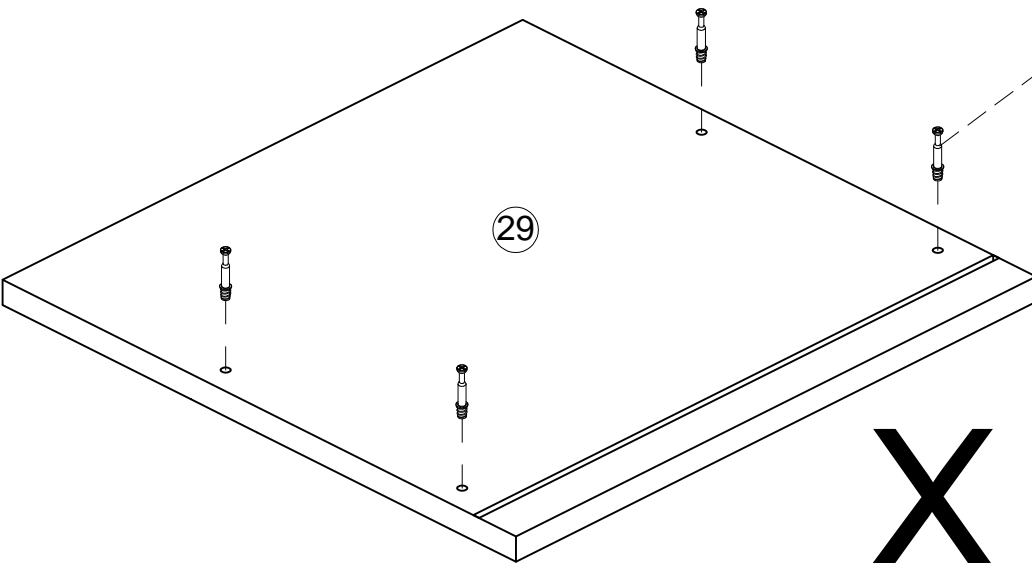

# X 2

B x8

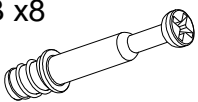

The thin plate needs to be fully inserted into the groove. If the insertion is not smooth, you can try pressing from the front or the back to make adjustments until the thin plate is fully inserted into the groove.

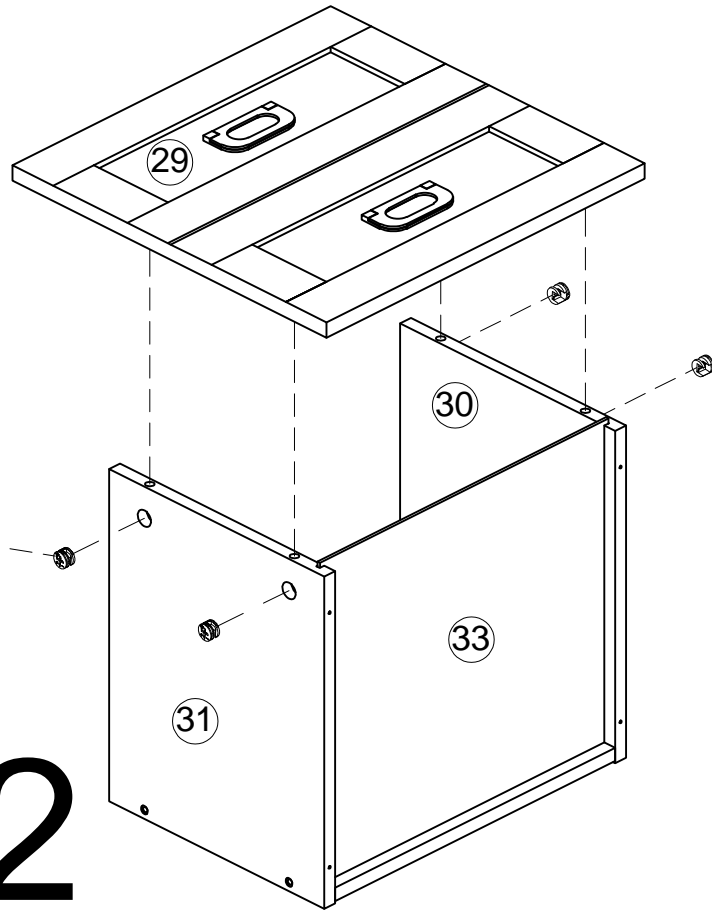
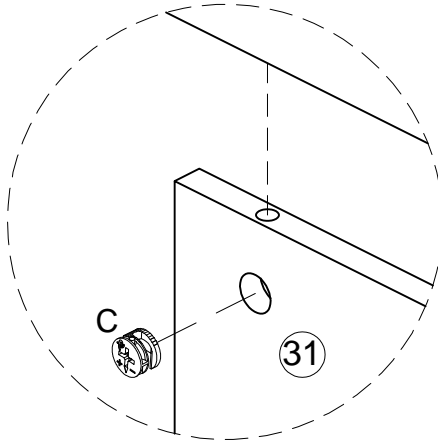

C x8



X 2

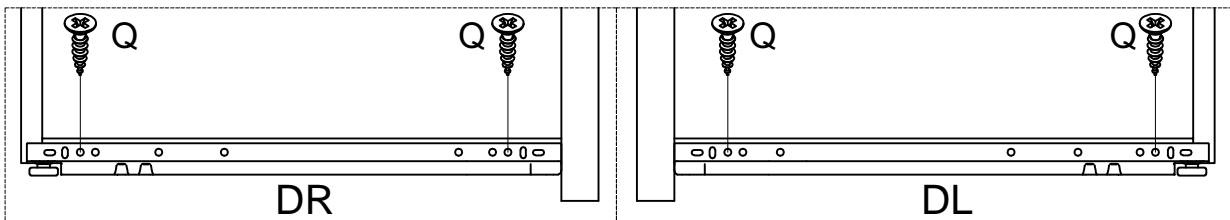

P	Q	T	W
X	✓	X	X
Ø6x3x10	Ø6x3x12	Ø8x4x14	Ø6x3x16

X 2

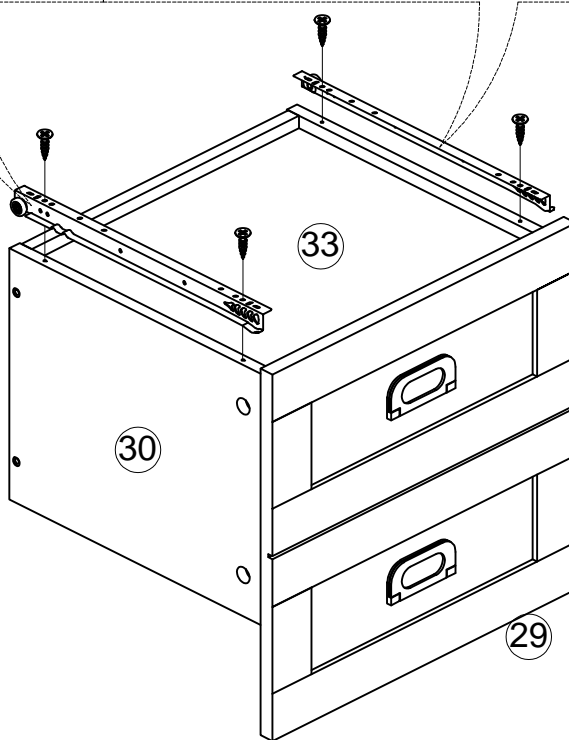

Q x8

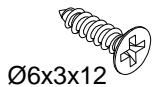

Ø6x3x12

G x2



DR

DL

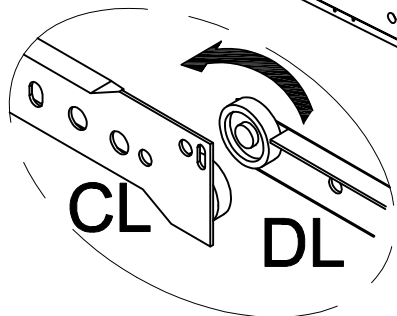
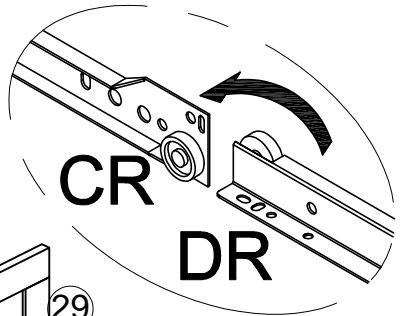
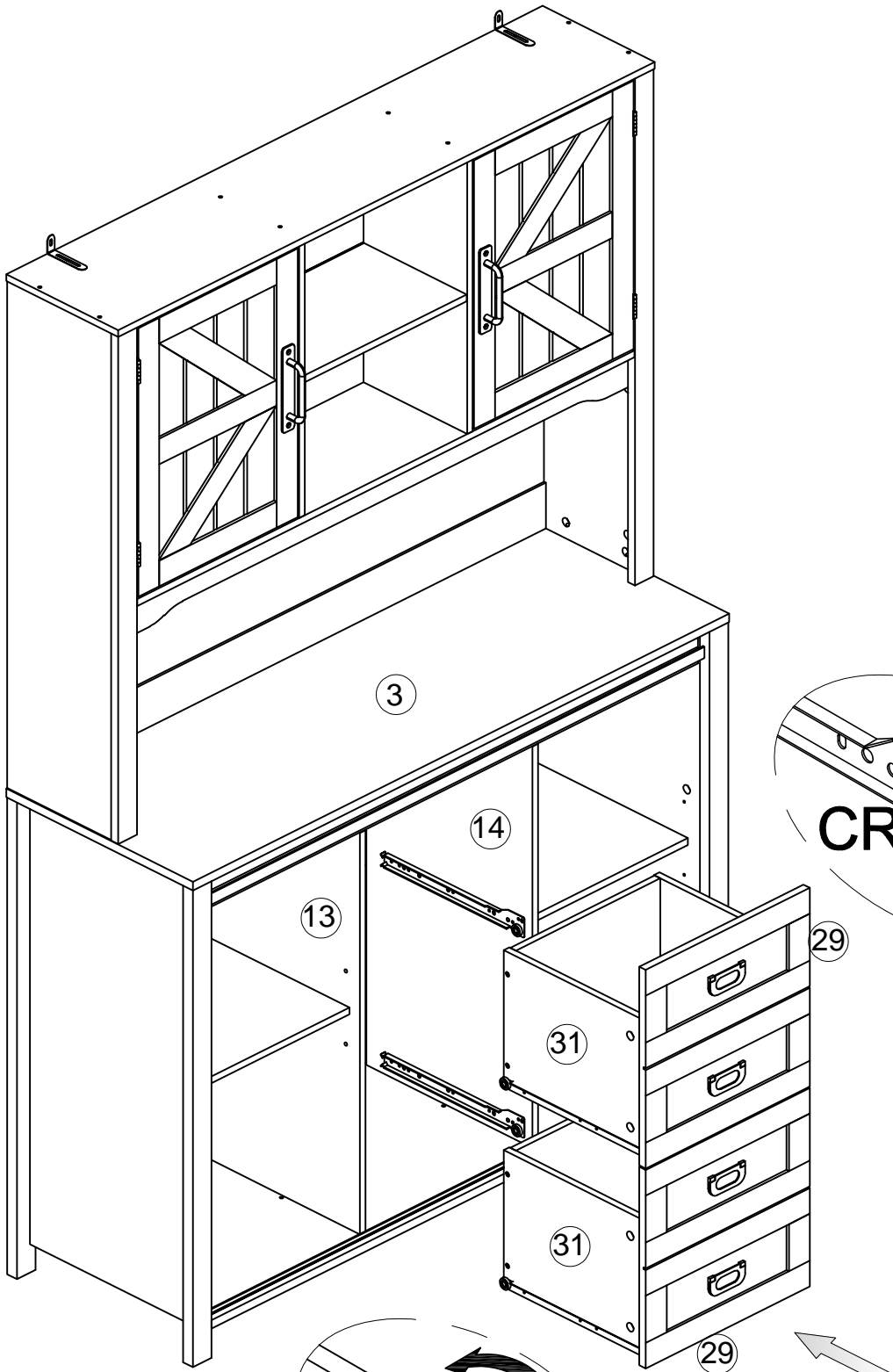

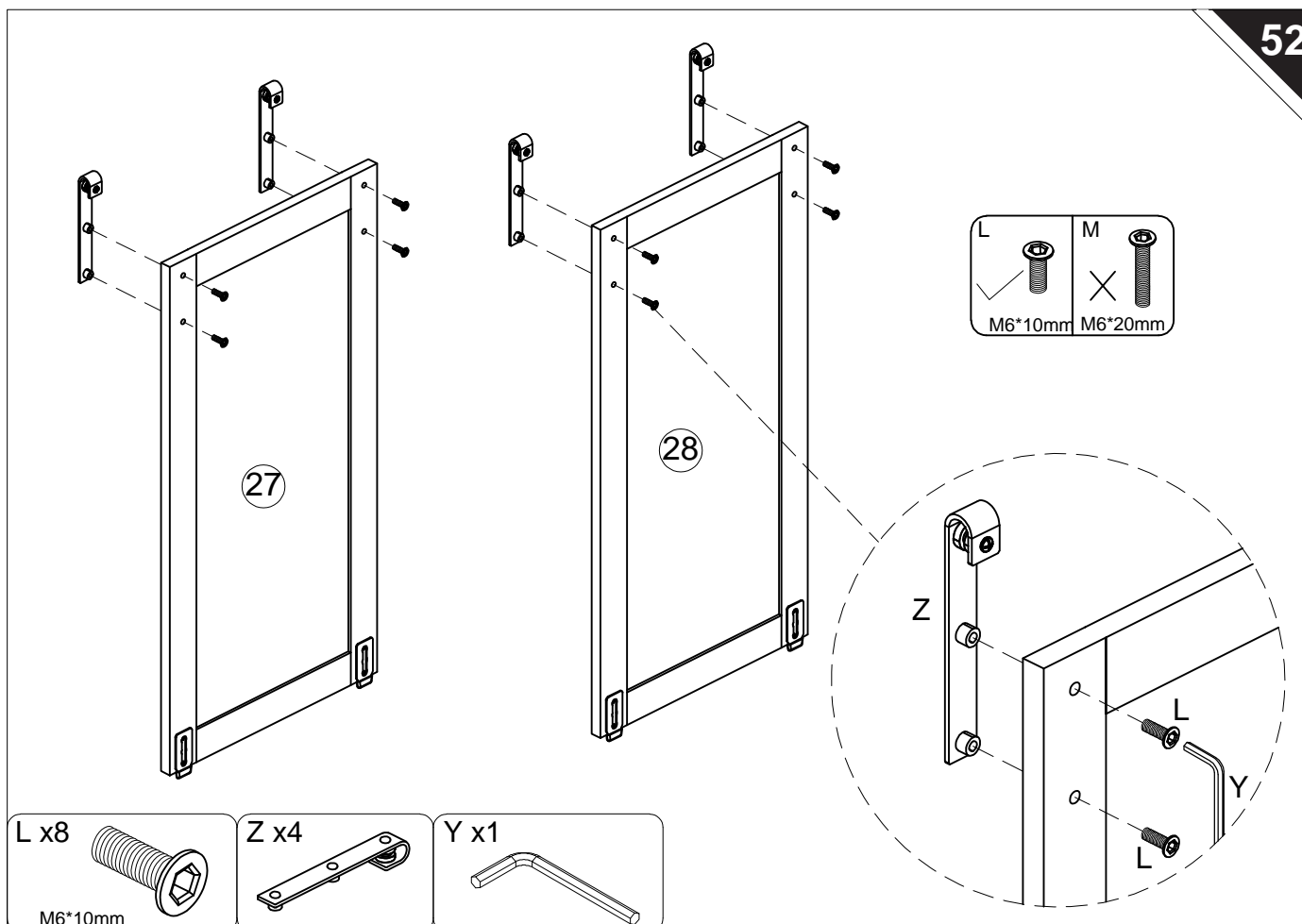
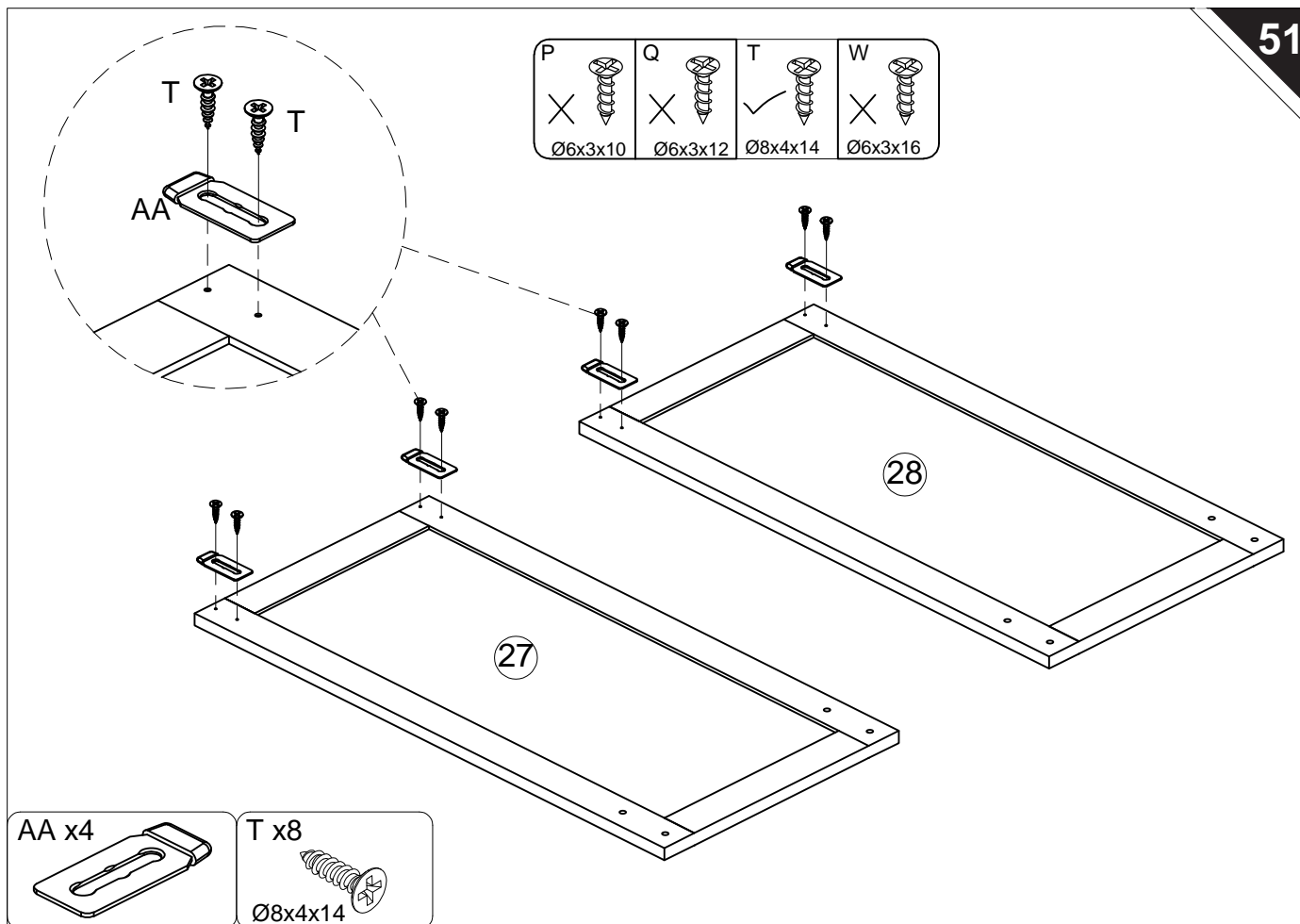

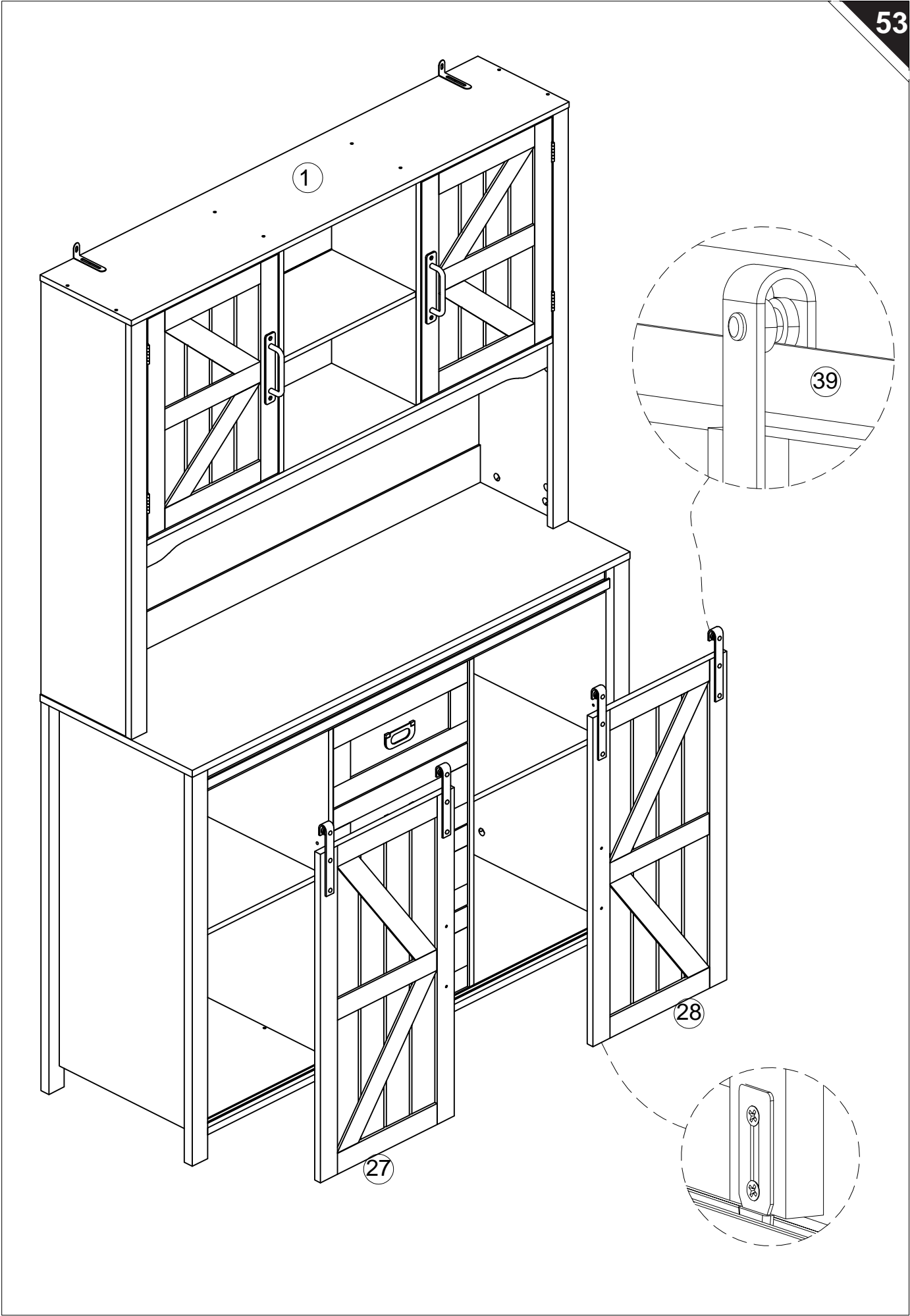

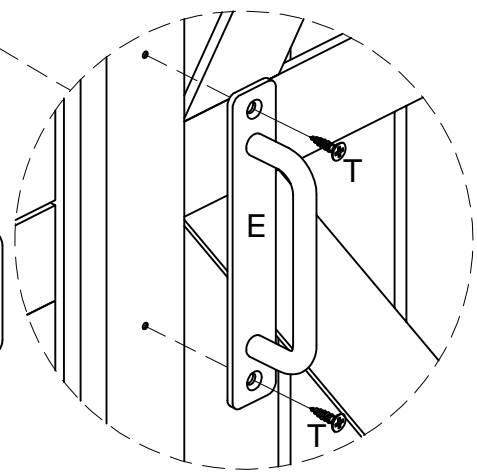
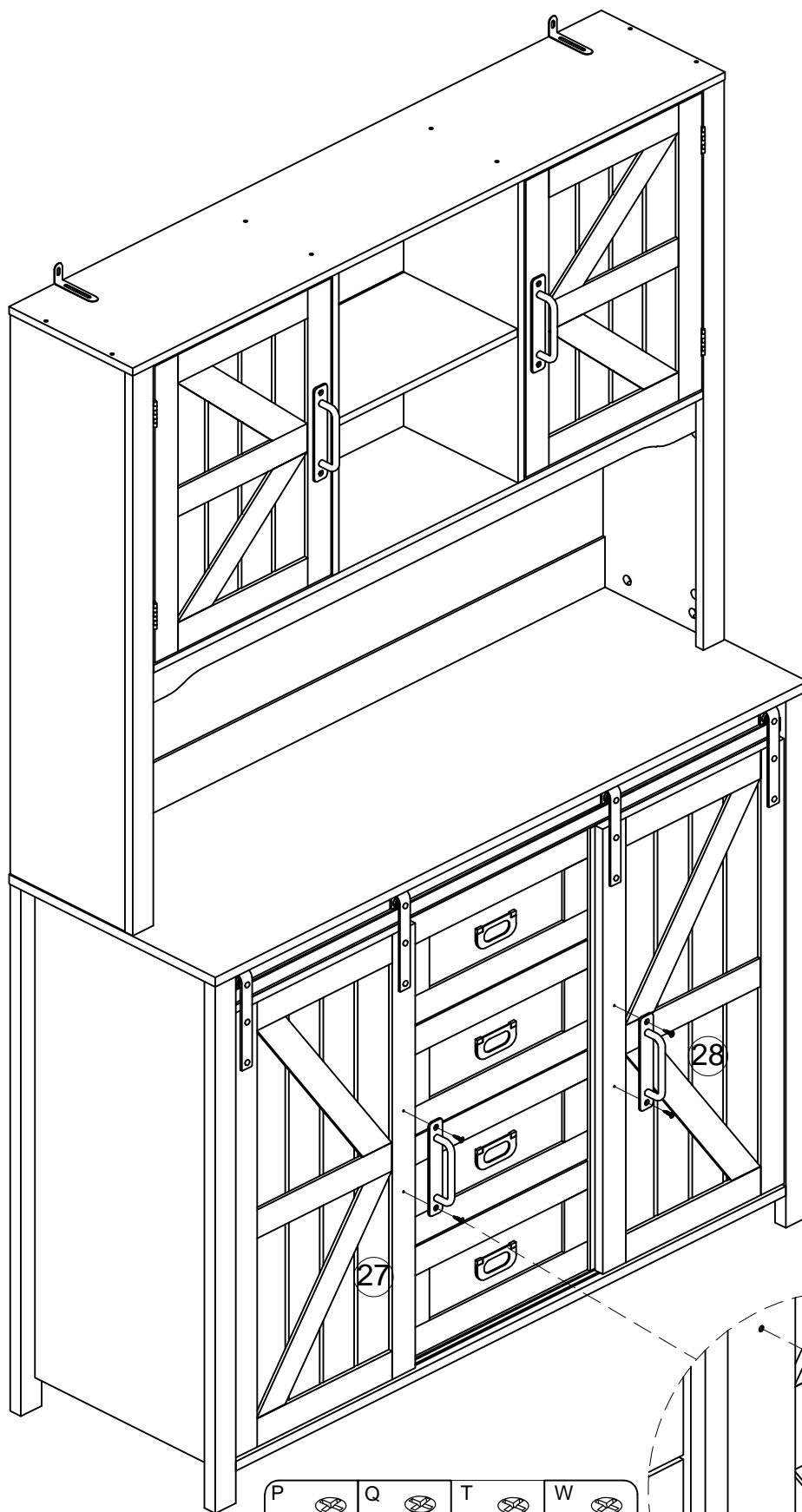

P	Q	T	W
X	X	✓	X
Ø6x3x10	Ø6x3x12	Ø8x4x14	Ø6x3x16

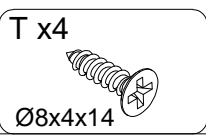
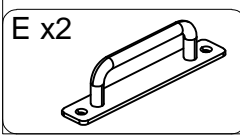

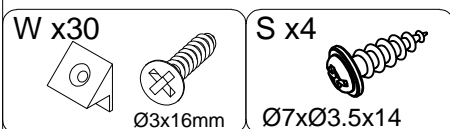
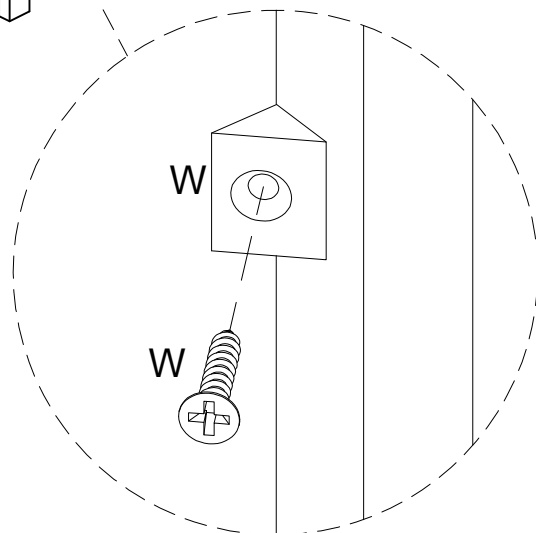
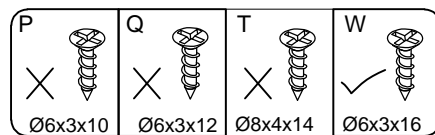
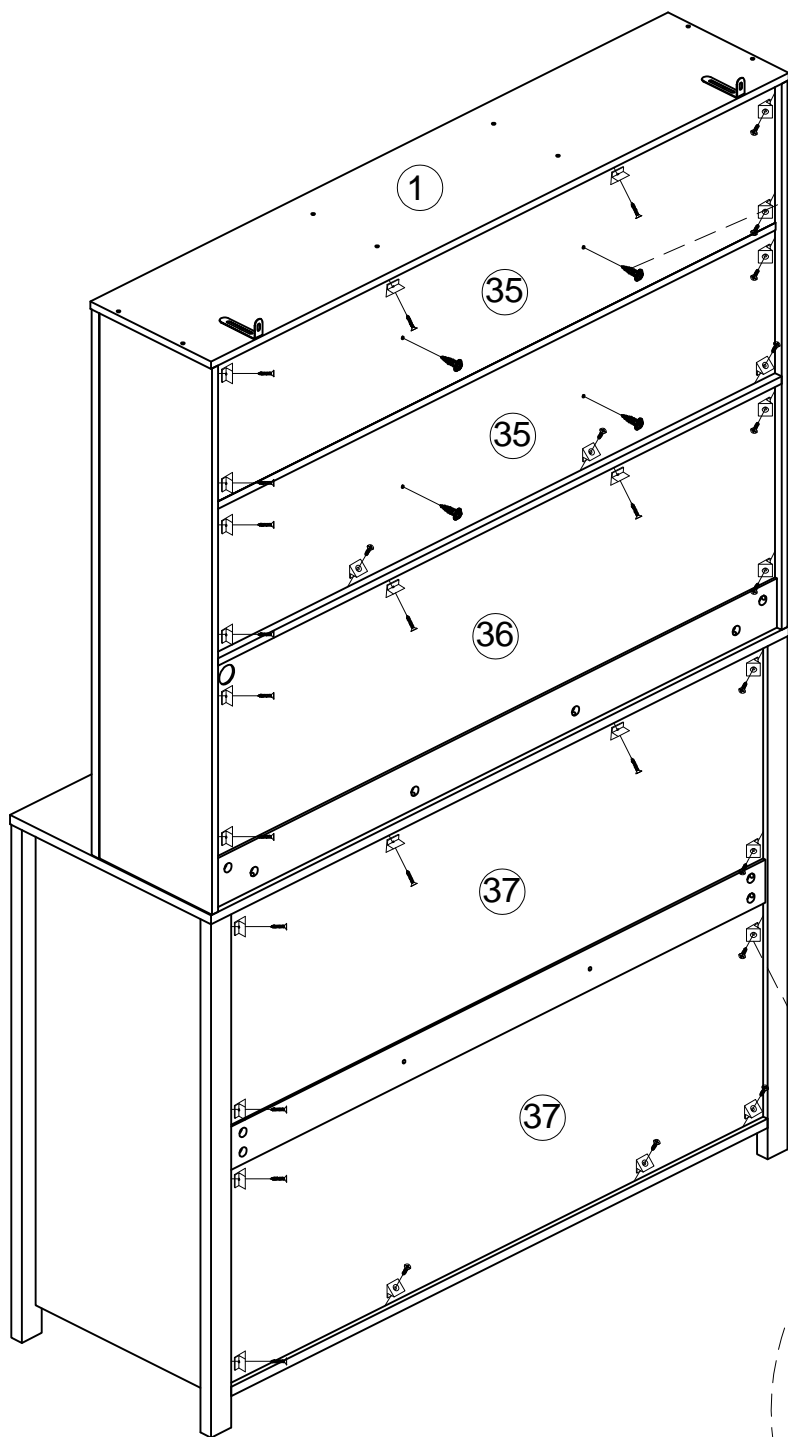
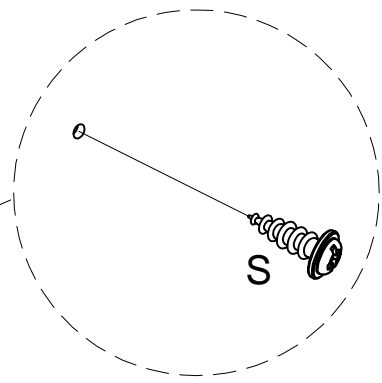
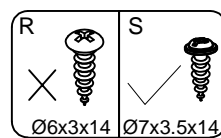

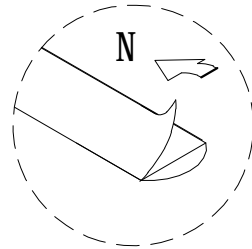
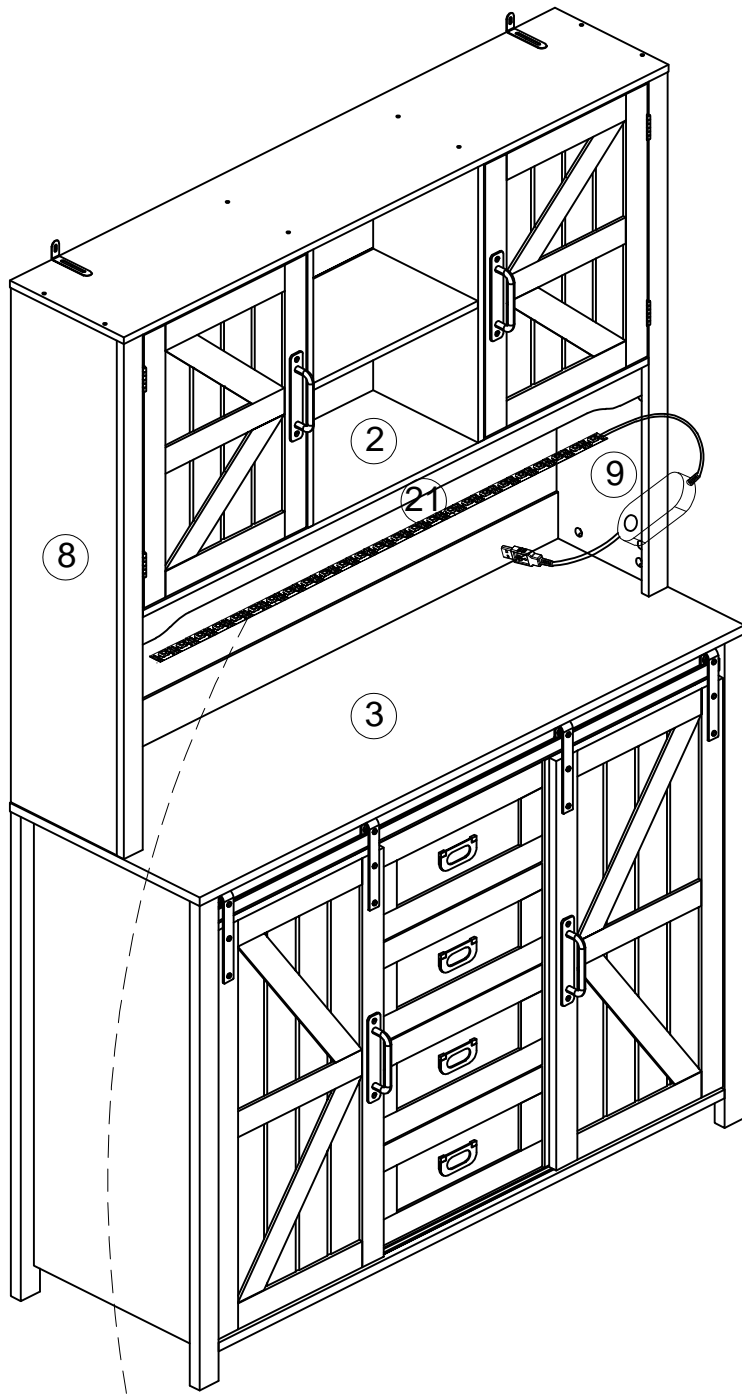

Please remove the film on the back of the lamp before installing the lamp strip to ensure that the lamp strip can be adhered to the board

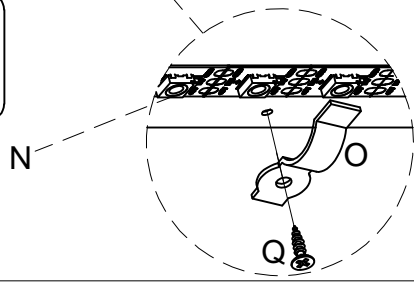
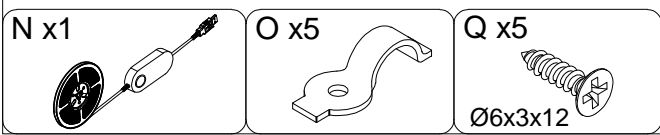
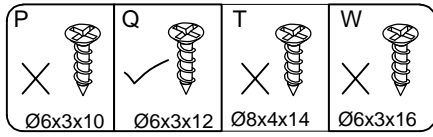
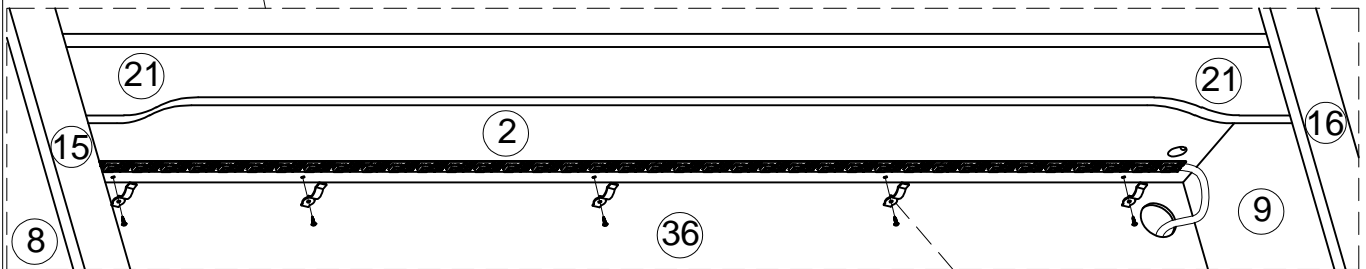

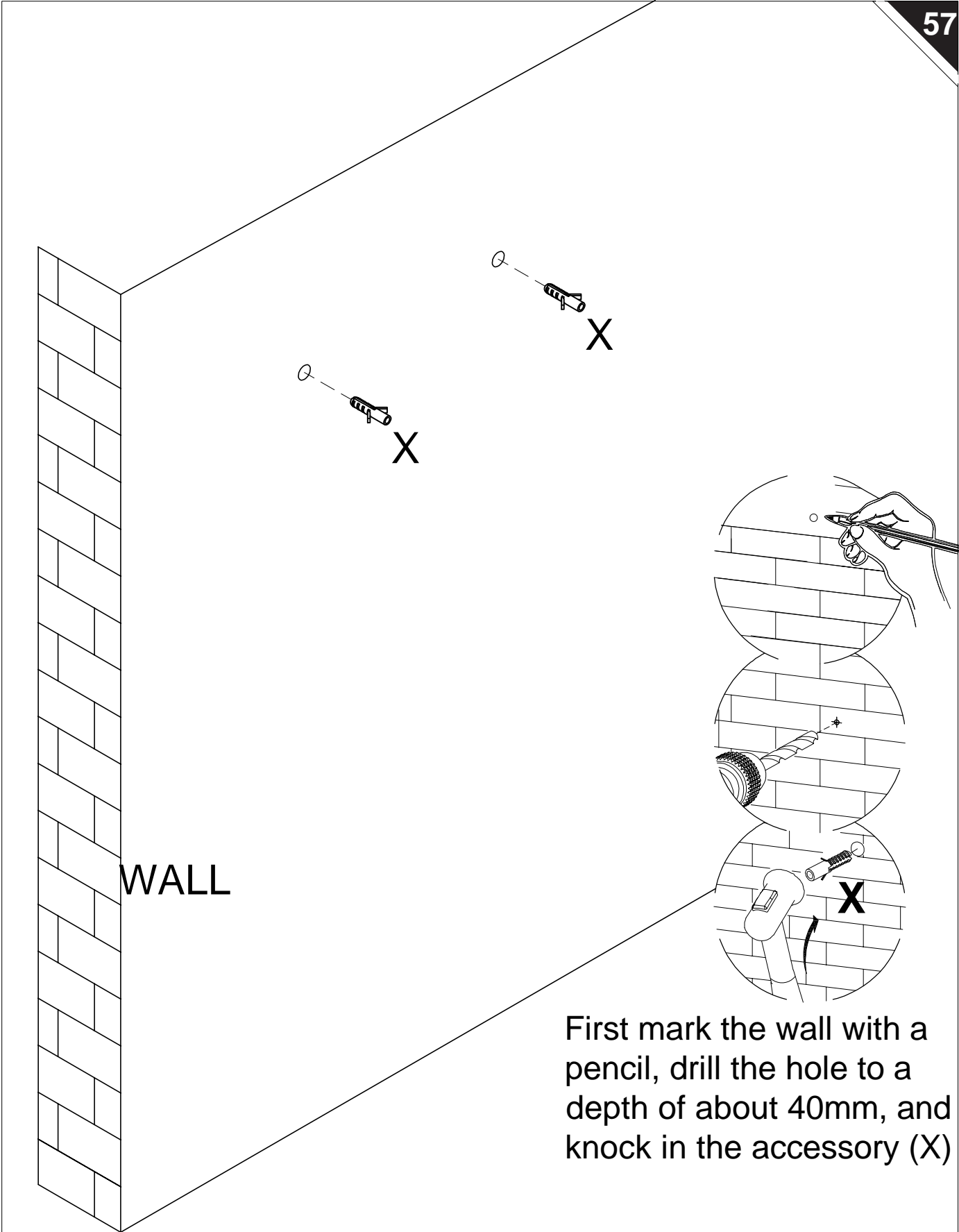

WALL

First mark the wall with a pencil, drill the hole to a depth of about 40mm, and knock in the accessory (X)

X x2

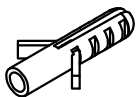

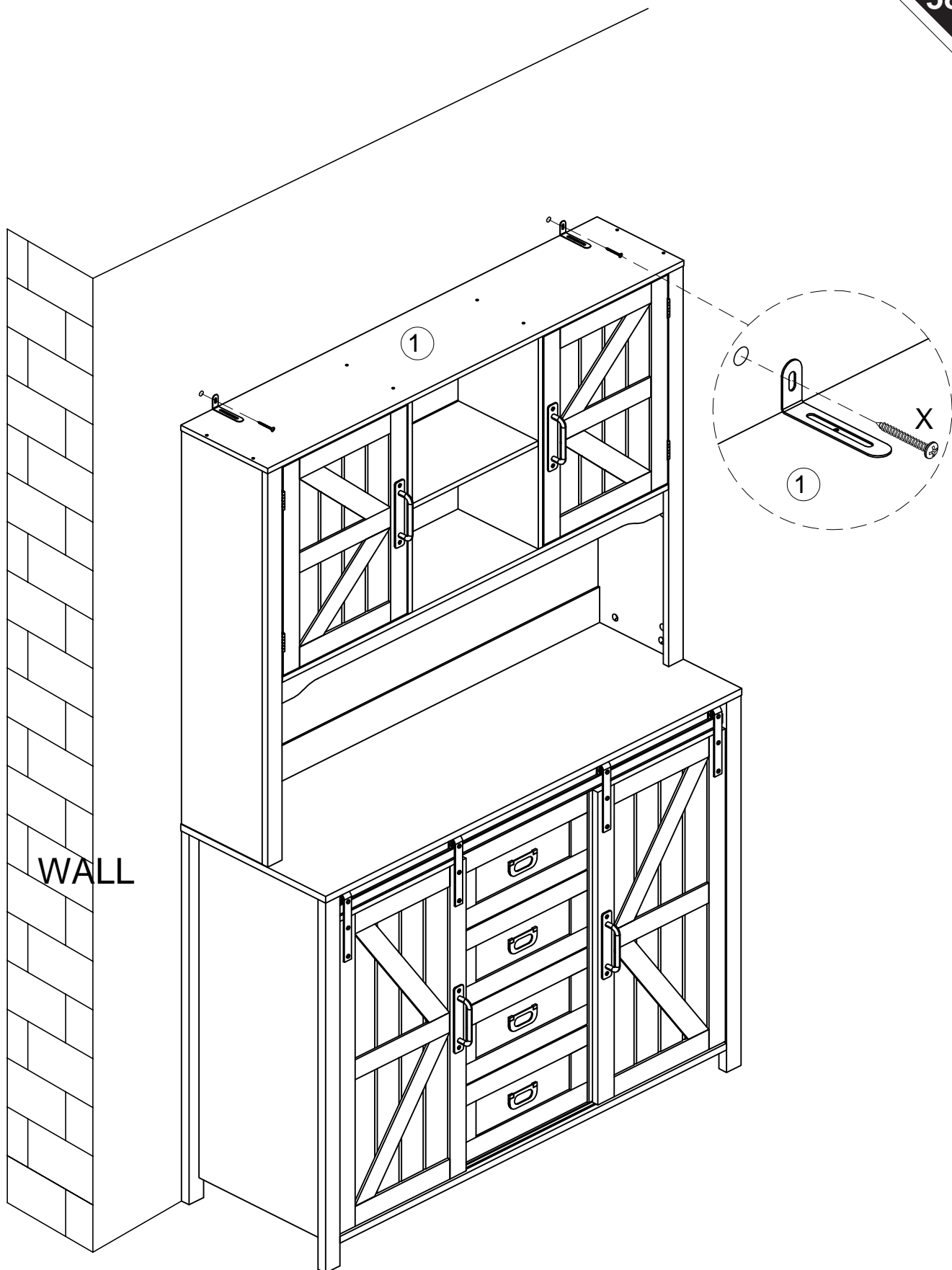

X x2



Ø8xØ4x40mm

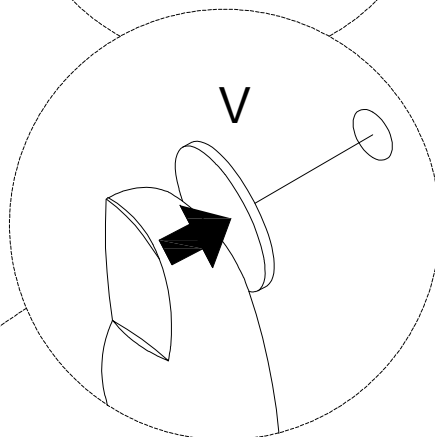
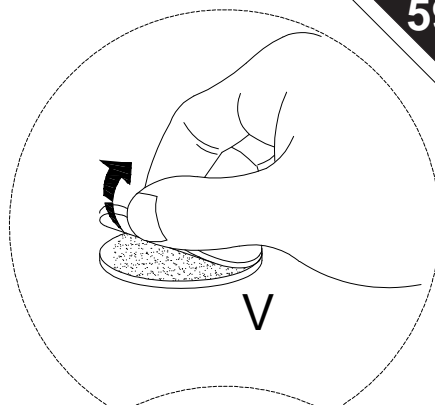
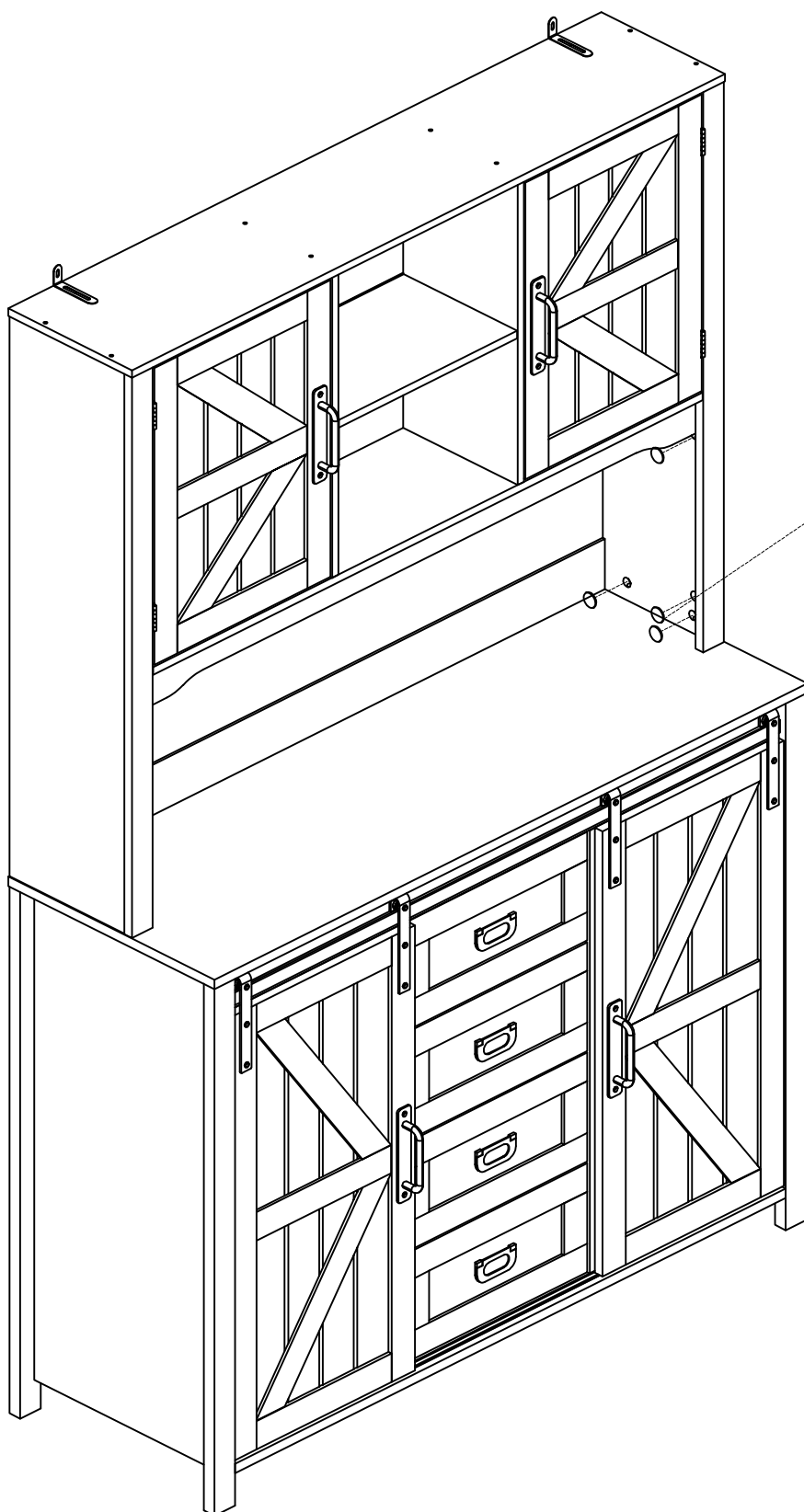

Cover the visible hole with a cap

V x52



Ø20mm

Shenzhen ZKT Technology Co., Ltd.  
 1/F, No. 101, Building B, No. 6, Tangwei Community Industrial Avenue,  
 Fuhai Street, Bao'an District, Shenzhen, China



# Certificate of Compliance

Certificate Number: ZKT-2403202772C

- Certificate's Holder** : Shenzhen Pinchengxin Technology Co., Ltd  
 3rd Floor, 8th Building Yuanling Industrial Zone, No. 39  
 Yuanlingcun Road, Shiyan Street, Bao'an District,  
 Shenzhen
- Manufacturer** : Shenzhen Pinchengxin Technology Co., Ltd  
 3rd Floor, 8th Building Yuanling Industrial Zone, No. 39  
 Yuanlingcun Road, Shiyan Street, Bao'an District,  
 Shenzhen
- Trade Mark** : N/A
- Product** : 5050 RGB LED Strip Lights with Bluetooth App Controller  
 and 2.4G Remote
- Model(s)** : 5050 RGB LED Strip Lights
- Test Standard** : Art.3.1(a) Safety EN IEC 62368-1:2020+A11:2020  
 Art.3.1(a) Health EN IEC 62311:2020  
 EN 50665:2017  
 Art.3.1(b) EMC ETSI EN 301 489-1 V2.2.3 (2019-11)  
 ETSI EN 301 489-17 V3.2.4 (2020-09)  
 Art.3.2 Radio ETSI EN 300 328 V2.2.2 (2019-07)

This Attestation of Compliance is issued on a voluntary basis for electrical equipment below the voltage limits of Radio Equipment Directive (RED) 2014/53/EU. The essential requirements are fulfilled accordingly based on the technical specifications applicable at the time of issuance.



This Certificate of Conformity is based on single evaluation of the submitted sample(s) of the above mentioned product. It does not imply an assessment of the whole product and relevant Directives to be observed.