

Sectional Sofa - HS010

Support@linsyhome.com

Assembly Instructions

Montageanleitung

Instrucciones de ensamblaje

Instructions de montage

Istruzioni di montaggio

English

This seating furniture is tested for domestic use according to EN-12520.

Care and cleaning

- Wipe clean with a cloth dampened in a mild cleaner.
- Wipe dry with a clean cloth.

Deutsch

Dieses Sitzmöbel ist für den Hausgebrauch getestet gemäß EN-12520.

Reinigung und Pflege

- Mit einem feuchten Tuch mit milder Seifenlösung abwischen.
- Trocken nachwischen.

Español

Este asiento se ha probado para uso doméstico según la norma EN-12520.

Mantenimiento y limpieza

- Limpiar con un paño humedecido con una suave solución jabonosa.
- Secar con un paño limpio.

Français

Ce siège a été testé pour un usage domestique, en conformité avec le règlement EN-12520.

Entretien et nettoyage

- Nettoyer avec un chiffon humide et une solution savonneuse.
- Essuyer avec un chiffon sec et propre.

Italiano

Questa seduta è stata testata per l'uso domestico in conformità alla norma EN-12520.

Istruzioni per la pulizia

- Pulisci con un panno inumidito in un detersivo poco concentrato.
- Asciuga con un panno asciutto.

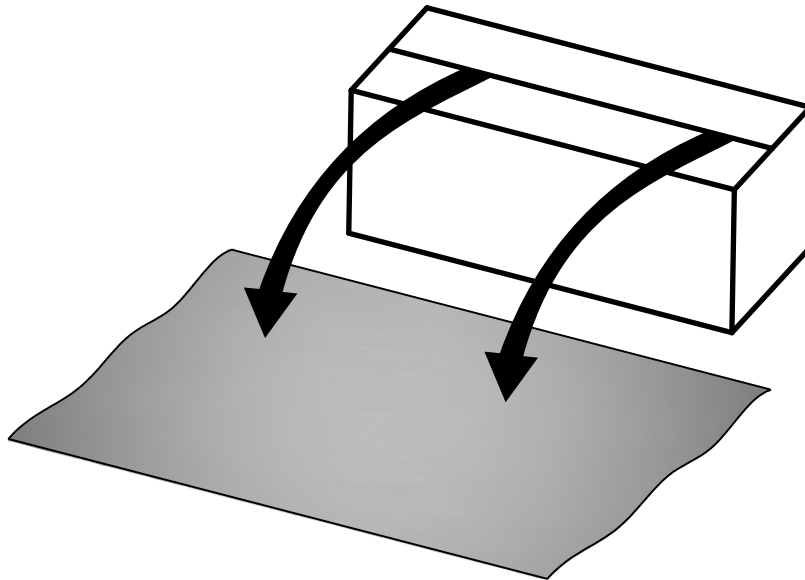



English

Please note that scissors are not included with the product delivery.

Deutsch

Bitte beachten Sie, dass Scheren nicht mit der Lieferung des Produkts enthalten sind.

Español

Por favor, tenga en cuenta que las tijeras no se envían con el producto.

Français

Veuillez noter que les ciseaux ne sont pas inclus dans la livraison du produit.

Italiano

Si prega di notare che le forbici non sono incluse nella consegna del prodotto.

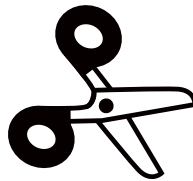

Package A1

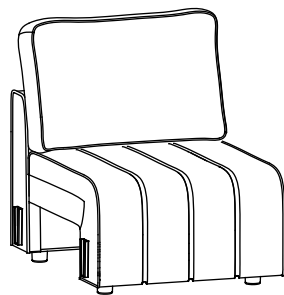

A

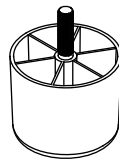

H=50mm
4X

B



Ø45 mm
4X

C

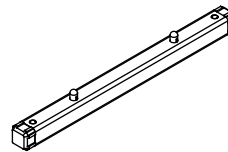

2X

Package C1

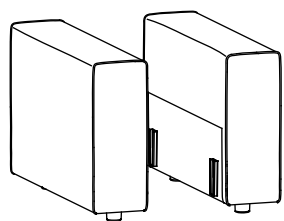

A

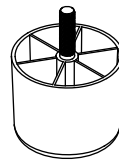

H=50mm
4X

B

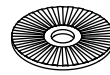

Ø45 mm
4X



English

Level uneven sofa by rotating plastic adjustment feet at base. Adjustable range: 5-15mm.

Deutsch

Sofa uneben? Drehen Sie die Kunststoff-FüÙe an der Basis zum Ausgleich. Einstellbereich: 5-15 mm.

Español

¿Sofá inestable? Gire los pies de plástico en la base para nivelar. Rango ajustable: 5-15 mm.

Français

Canapé instable ? Tournez les pieds réglables en plastique à la base. Plage de réglage : 5-15 mm.

Italiano

Divano instabile? Ruoti i piedini regolabili in plastica sulla base. Intervallo regolazione: 5-15 mm.

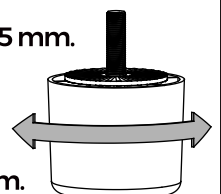

1

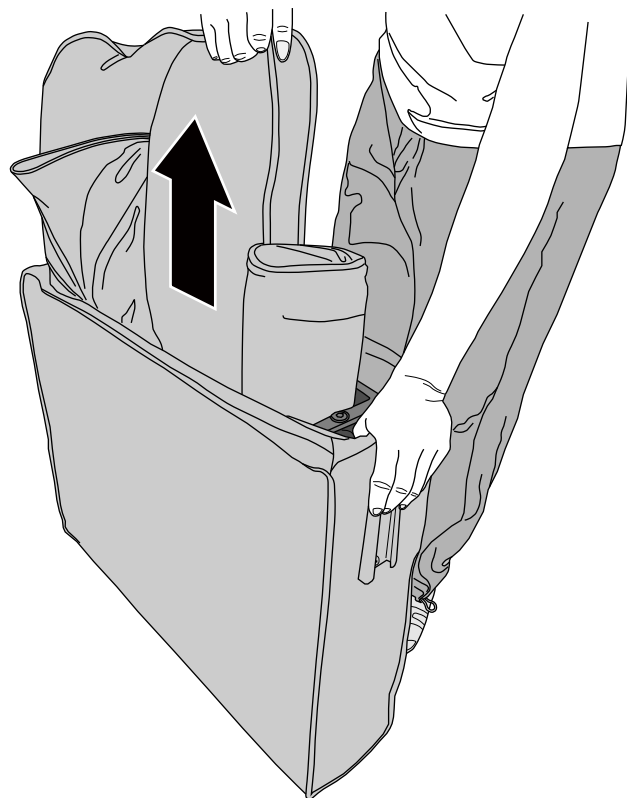

English

Open the zipper at the bottom of the backrest and you can take out the cushions.

Deutsch

Öffnen Sie den Reißverschluss an der Unterseite der Rückenlehne, um die Kissen herauszunehmen.

Español

Abre la cremallera en la parte inferior del respaldo para sacar las almohadas.

Français

Ouvrez la fermeture éclair en bas du dossier pour sortir les coussins.

Italiano

Apri la cerniera nella parte inferiore dello schienale per prendere i cuscini.

2

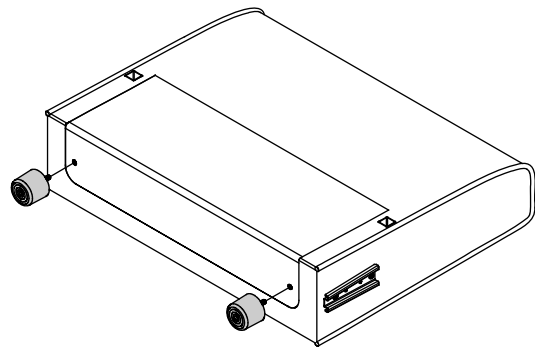
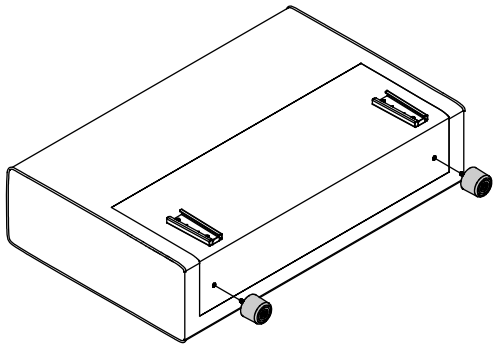
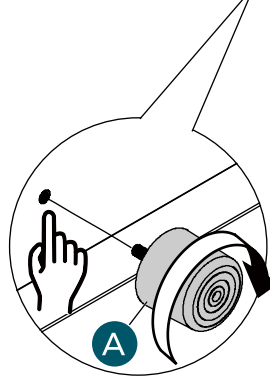
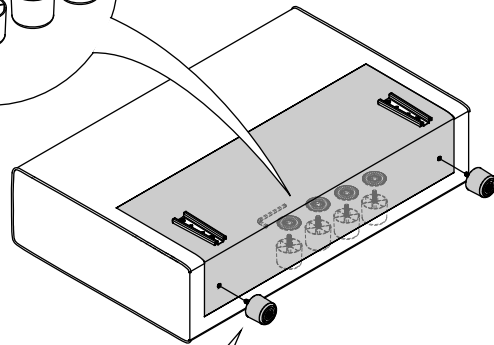
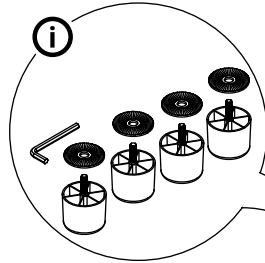
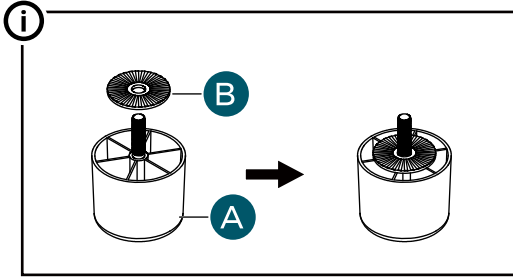

3

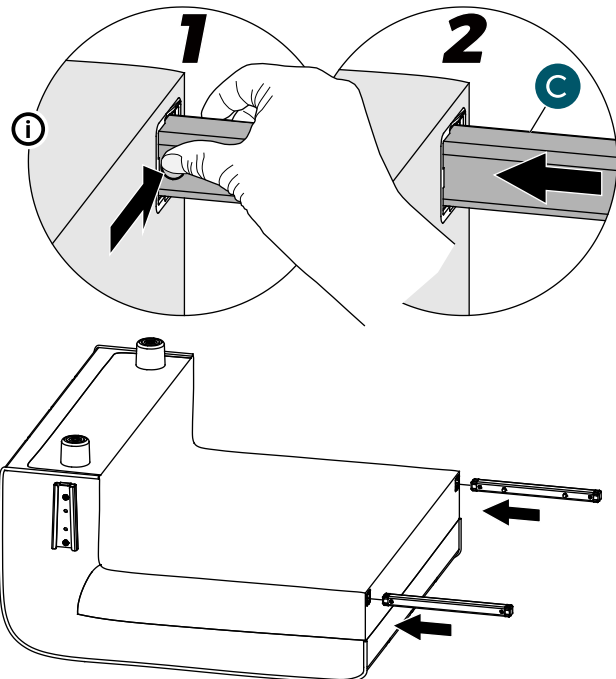
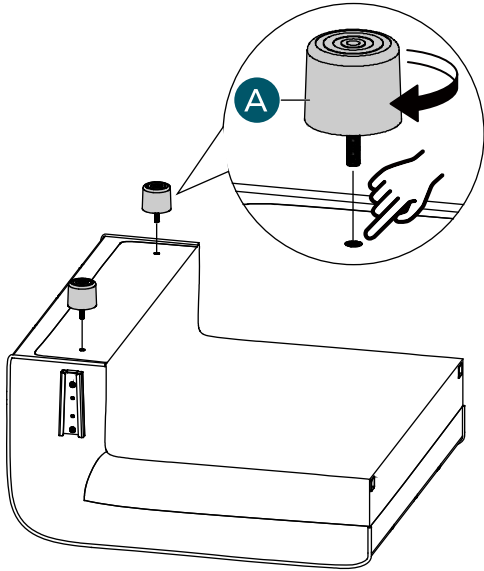

4

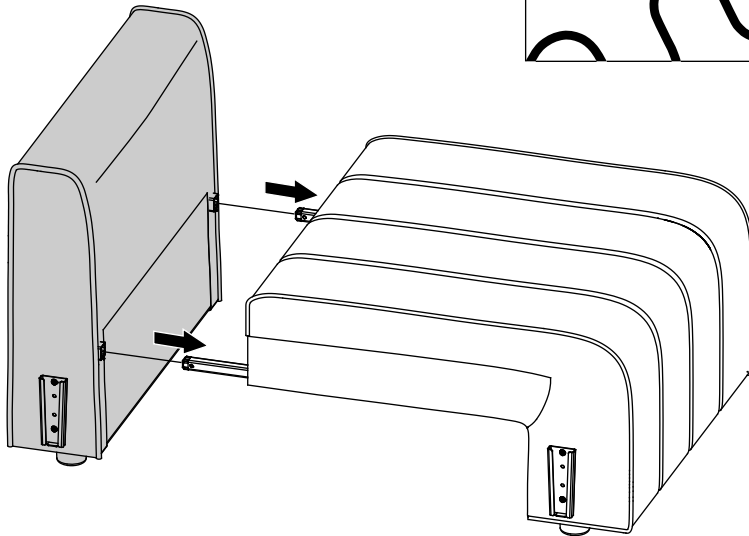
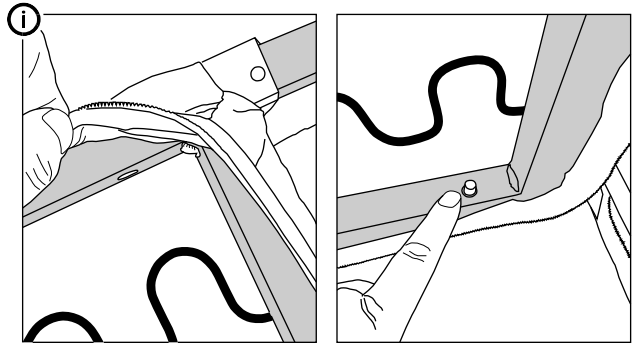

5

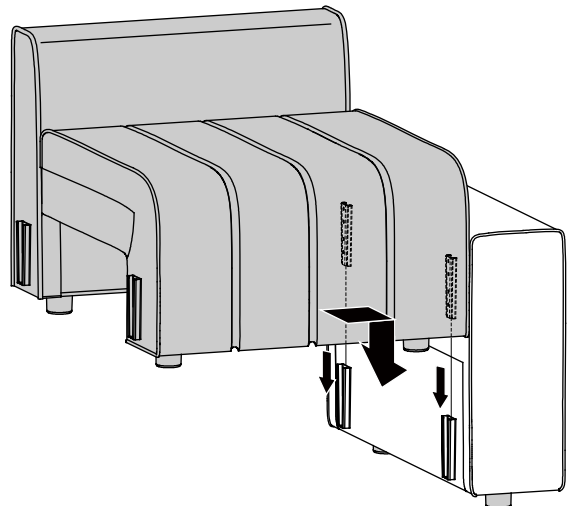
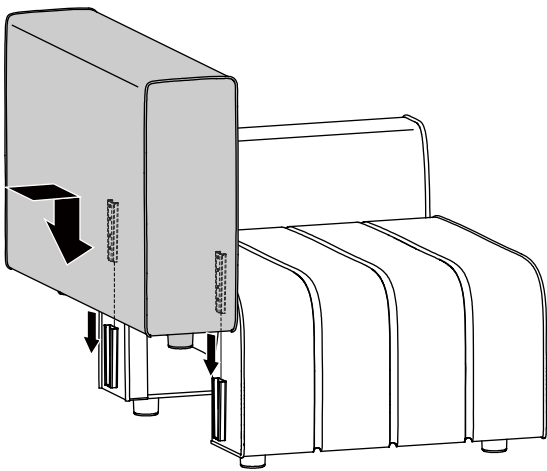
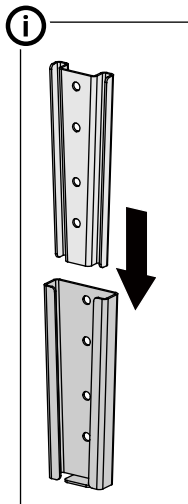

i

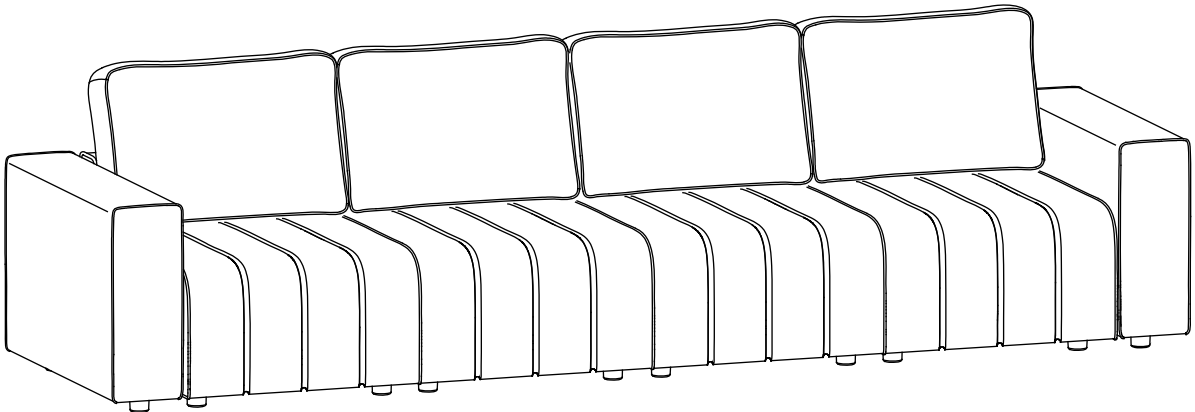
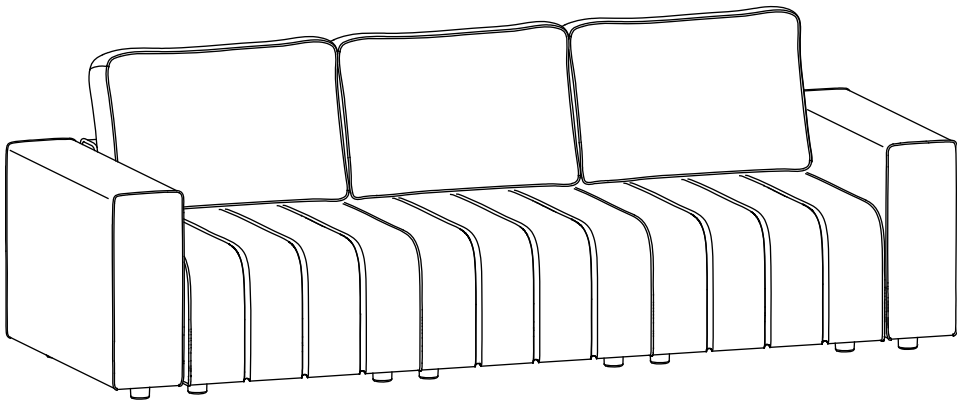
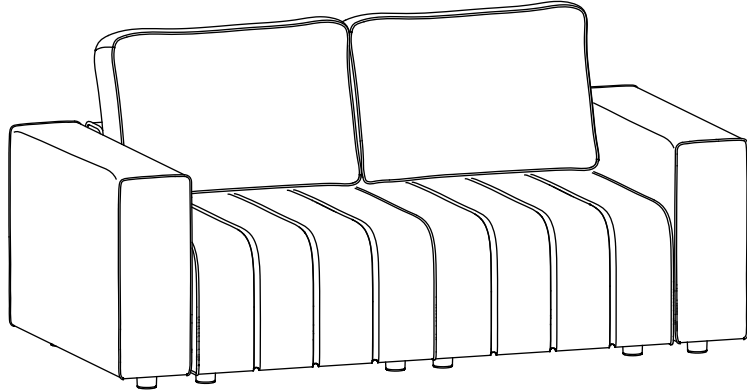

• • • • •

6

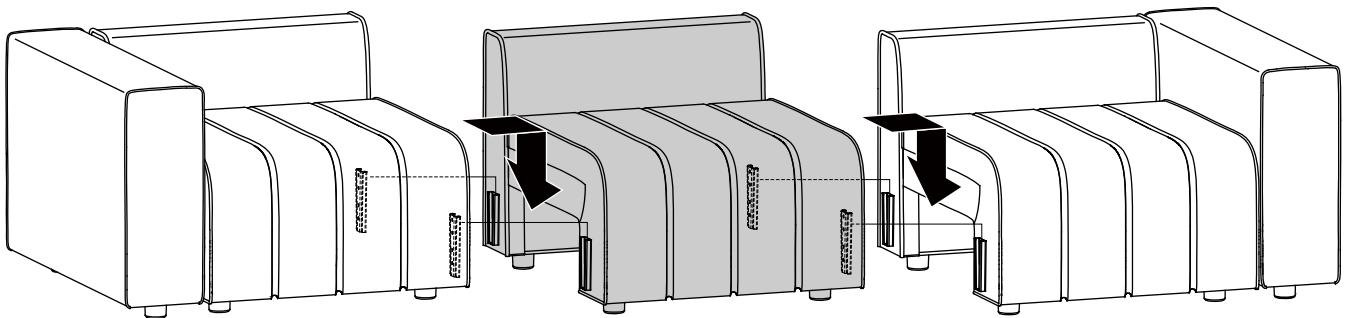
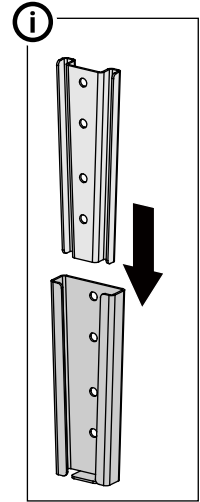
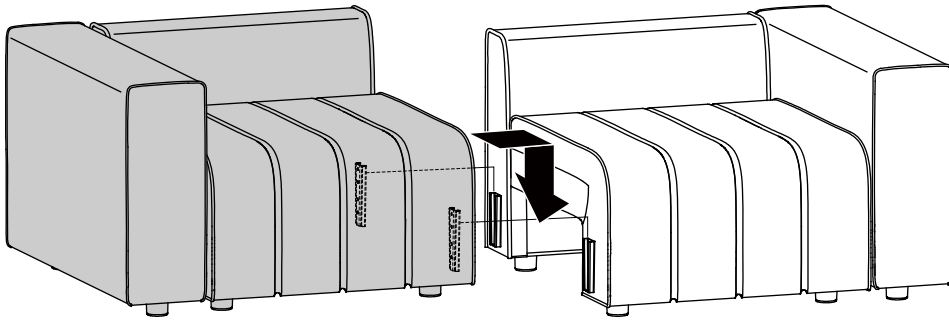

7

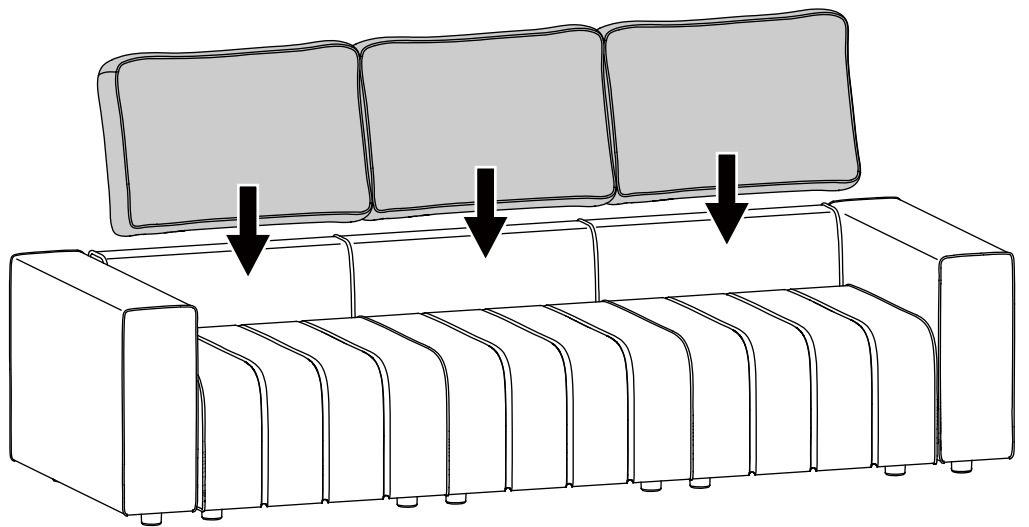
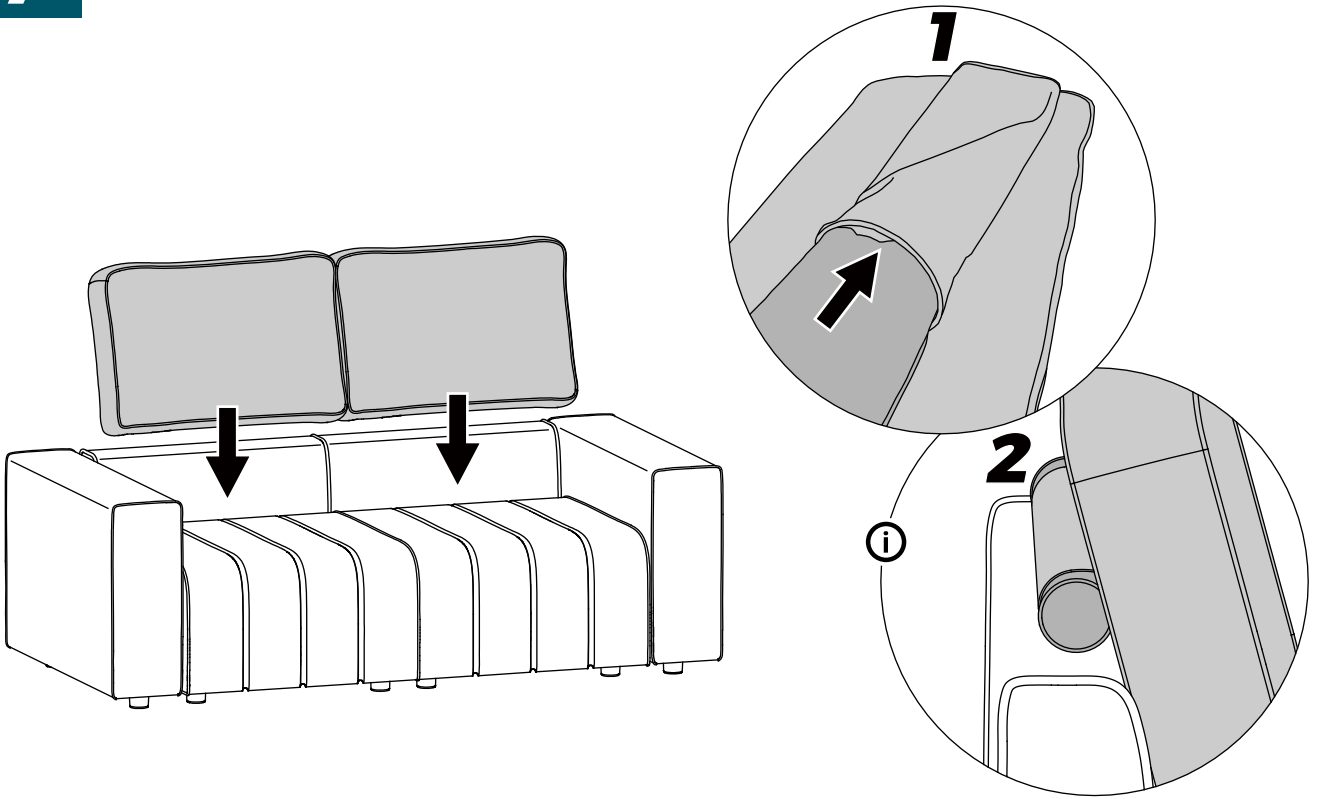



(English)

Dear Valued Customer,

Thank you for bringing LINSY HOME into your life, where our mission is to "Make Life Better."

Your happiness and satisfaction are at the heart of what we do.

If our products have brightened your day, we're thrilled and eager to share that light further.

Encountering an issue? We're here to help swiftly and effectively.

Here's how you can reach us:

Get in Touch

Email us at Support@linsyhome.com

Share Details

Provide your order number and a photo of the issue, along with a brief description.

Await Solutions

Our team will quickly review and propose the right after-sales solution to make things right.

Your feedback propels us forward.

We're committed to ensuring your LINSY HOME experience is always positive.

Warmest thanks,

The LINSY HOME Team

(Deutsch)

Sehr geehrter Kunde,

Vielen Dank, dass Sie LINSY HOME in Ihr Leben gebracht haben, in dem es unsere Mission ist, "das Leben besser zu machen".

Ihr Glück und Ihre Zufriedenheit stehen im Mittelpunkt dessen, was wir tun.

Wenn unsere Produkte Ihren Tag aufgeheitert haben, freuen wir uns darauf, dieses Licht weiter zu teilen.

Auf ein Problem gestoßen? Wir sind hier, um schnell und effektiv zu helfen.

So erreichen Sie uns:

Kontaktieren Sie uns

Senden Sie uns eine E-Mail an Support@linsyhome.com

Details teilen

Geben Sie Ihre Bestellnummer und ein Foto der Nummer zusammen mit einer kurzen Beschreibung an.

Warten Sie auf Lösungen

Unser Team wird schnell die richtige After-Sales-Lösung überprüfen und vorschlagen, um die Dinge richtig zu machen.

Ihr Feedback treibt uns voran.

Wir sind bestrebt, sicherzustellen, dass Ihr LINSY HOME-Erlebnis immer positiv ist.

Herzlichen Dank,
Das LINSY HOME Team



(Español)

Estimado cliente,

Gracias por traer a LINSY HOME a tu vida, donde nuestra misión es "Mejorar la vida".

Tu felicidad y satisfacción están en el corazón de lo que hacemos.

Si nuestros productos han alegrado su día, estamos encantados y ansiosos por compartir más esa luz.

¿Encuentras un problema? Estamos aquí para ayudar de forma rápida y eficaz.

Así es como puede comunicarse con nosotros:

Póngase en contacto

Envíenos un correo electrónico a Support@linsyhome.com

Compartir detalles

Proporcione su número de pedido y una foto del número, junto con una breve descripción.

Esperar soluciones

Nuestro equipo revisará y propondrá rápidamente la solución postventa adecuada para hacer las cosas bien.

Tus comentarios nos impulsan hacia adelante.

Estamos comprometidos a garantizar que su experiencia en LINSY HOME sea siempre positiva.

Muchas gracias,

El equipo de LINSY HOME



(Français)

Cher client,

Merci d'avoir amené LINSY HOME dans votre vie, où notre mission est de "rendre la vie meilleure". Votre bonheur et votre satisfaction sont au cœur de ce que nous faisons. Si nos produits ont égayé votre journée, nous sommes ravis et impatients de partager davantage cette lumière.

Vous rencontrez un problème ? Nous sommes là pour vous aider rapidement et efficacement. Voici comment vous pouvez nous joindre :

Contactez-nous

Envoyez-nous un courriel à Support@linsyhome.com

Partager les détails

Fournissez votre numéro de commande et une photo du problème, ainsi qu'une brève description.

Attendre des solutions

Notre équipe examinera et proposera rapidement la bonne solution après-vente pour arranger les choses.

Vos commentaires nous propulsent vers l'avant.

Nous nous engageons à faire en sorte que votre expérience LINSY HOME soit toujours positive.

Un grand merci,
L'équipe LINSY HOME

(Italiano)

Gentile Cliente,

Grazie per aver portato LINSY HOME nella tua vita, dove la nostra missione è "Rendere la vita migliore". La tua felicità e soddisfazione sono al centro di ciò che facciamo. Se i nostri prodotti hanno illuminato la tua giornata, siamo entusiasti e desiderosi di condividere ulteriormente quella luce.

Riscontrando un problema? Siamo qui per aiutarti in modo rapido ed efficace.
Ecco come puoi raggiungerci:

Mettiti in contatto

Inviaci un'e-mail a Support@linsyhome.com

Condividi Dettagli

Fornisci il tuo numero d'ordine e una foto del numero, insieme a una breve descrizione.

Attendi soluzioni

Il nostro team esaminerà e proporrà rapidamente la giusta soluzione post-vendita per sistemare le cose.

Il tuo feedback ci spinge in avanti.

Ci impegniamo a garantire che la tua esperienza LINSY HOME sia sempre positiva.

Grazie di cuore,
Il team di LINSY HOME