

Lifting Chair

PRODUCT GUIDE &
ASSEMBLY INSTRUCTIONS

Should you prefer to speak with a customer service representative, you may call toll free.

Guidelines

FAILURE TO FOLLOW THESE WARNINGS
WHEN IN USE COULD RESULT IN INJURY

- Do not stand on the item or use as a step ladder
- Do not use this item unless all bolts and screws are firmly secured and fastened.
- Check all bolts and screws every 90 days. As necessary tighten if any are loose.
- Lift up then move. Pushing over or dragging this product can result in an injury or cause damage to the floor and piece.

WARNING:

DO NOT LET CHILDREN PLAY IN OR AROUND THE UNIT DUE TO THE POSSIBLE RISK OF INJURY.

Pre-Assembly Preparation:

Please read through this instruction booklet before beginning assembly of this item.

Two adults are recommended for assembly.

- Clear out the space for assembly and lay out all parts on Parts List, extra room will allow you to easily determine if all the pieces are present.
- Save all packing materials until assembly is complete to avoid accidentally discarding smaller parts or hardware.
- Keep small parts and pieces away from children and pets until fully assembled.
- Please check for any loose screws and tighten them before you use.

Parts List

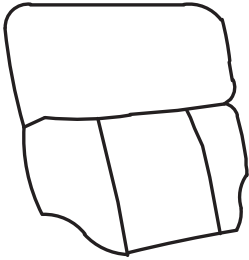

① Back Frame (1)

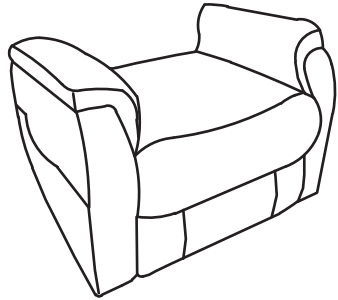

② Seat Frame (1)

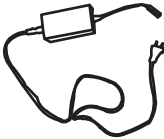

Ⓐ AC Adaptor (1)



Ⓑ Remote Control (1)

Step 1

1. Make sure all parts have been removed from the carton. Place them on a protected surface or carpet.
2. Check all parts and hardware against the “Parts List.”
3. Slide the Back Frame (1) into the Seat Frame (2), aligning the bracket on the Back Frame (1) until fully engaged.

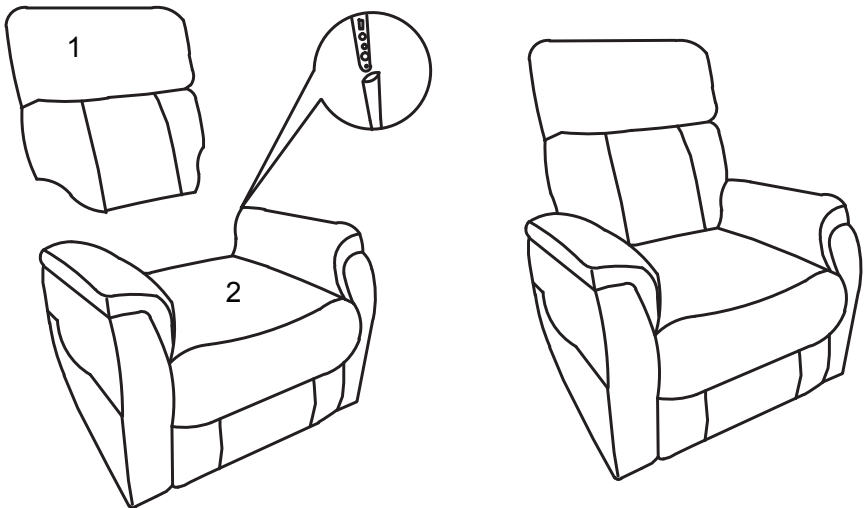

Step 2

Connect the AC/DC Adaptor (A) and Remote Control (B) to the chair as shown in the below image.

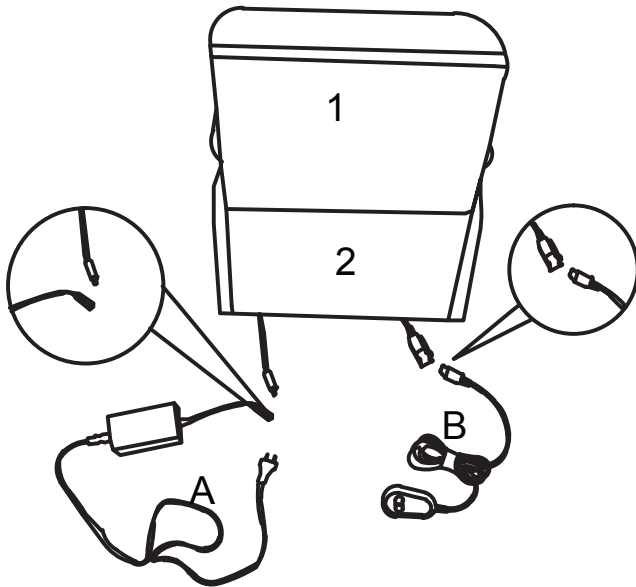

Step 3

1. Connect the AC/DC Adaptor (A) to your electrical outlet.
2. Use the Remote Control (B) to adjust the position of the chair.

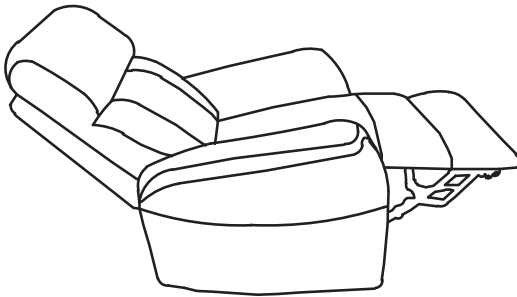
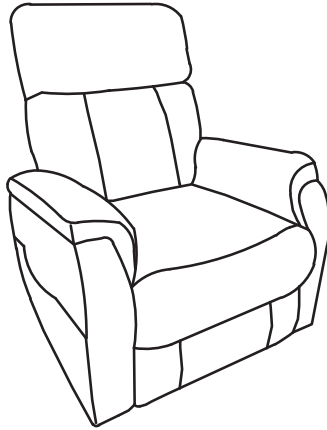

Product Dimension

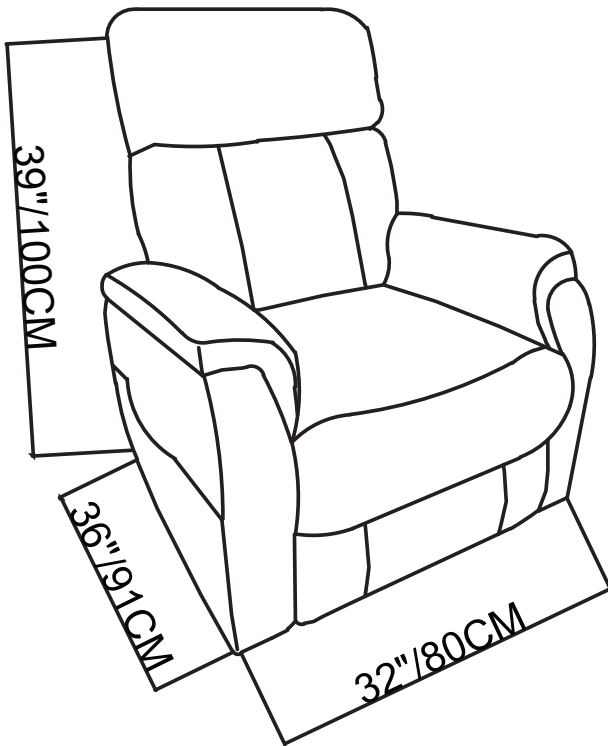

Product Dimension

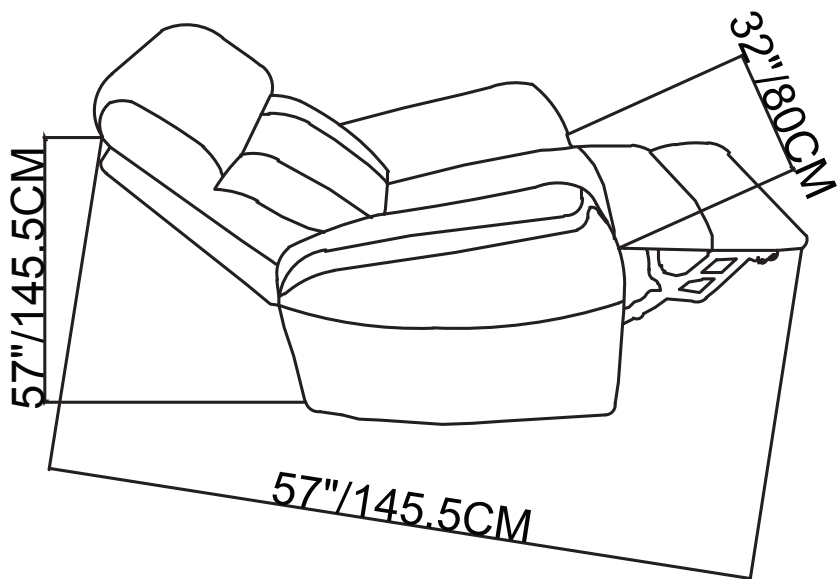

Limited Warranty

The manufacturer's products are warranted against defects in material and workmanship while owned by the "Original Purchaser". The term "Original Purchaser" is defined as the party or entity which purchases this manufacturer's furniture from an authorized retailer as shown by the original sales receipt. This warranty does not apply to "as is" or previously owned products.

The manufacturer warrants its products to be free from defects in materials and workmanship (normal wear and tear, fading and stretching excepted), for one year from the date of purchase, except as provided below under the limited warranty. The exceptions or exclusions to this warranty are as follows:

1. Any warranty claim that is submitted after the limited warranty period, or without proper proof of purchase will not include the cost of parts, labor, or delivery.
2. This warranty shall not apply to the manufacturer's products which have been subjected to misuse, neglect, alteration, modification, or attachments, either caused by the Original Purchaser, shipping, storage, accident, fire, flood, or acts of God.

In the event of a defect in material or workmanship covered by this warranty, the manufacturer will repair or replace, at their discretion, without charge the warranted parts within a reasonable amount of time. We reserve the right to require damaged parts be returned to us upon request. Natural markings such as scars, brands, grain variations, wrinkles, color variations, etc. will be considered normal characteristics and not construed as defects.

For claims or questions concerning this warranty, please contact customer service department on the web. Be prepared to provide your name, address, daytime phone number, the model and purchase order number of the product, date of purchase, and the website where it was purchased. The manufacturer requires that the original sales receipt be submitted with all requests to confirm that you are the Original Purchaser according to our written warranty.

This warranty gives you specific rights, and you may also have other rights, which vary from state to state (or country to country). All warranties are limited to the Original Purchaser for normal use. Should you prefer to speak with a service representative, you may call toll free.