

Assembly Instructions

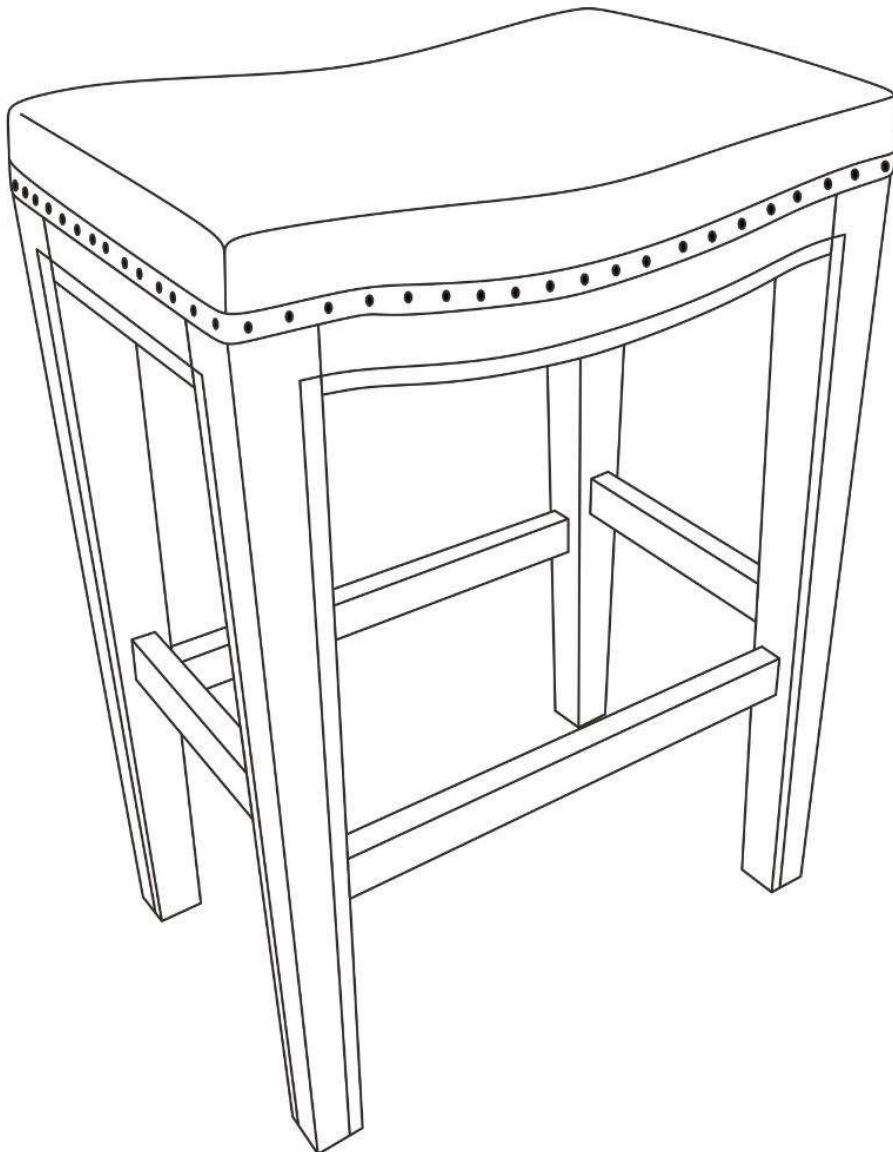

Caution: Please read this carefully before you proceed

Please look in the bottom of seat for hardware packs and legs





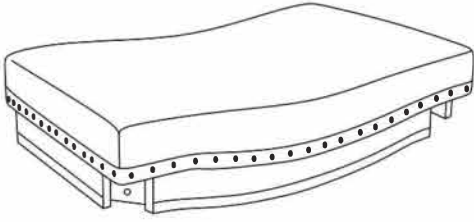
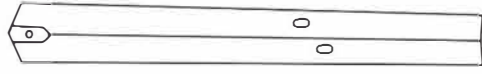

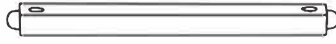
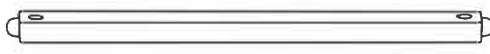
Stool



Part List

Label	Picture	Description	QTY
A		Stool Seat	1
B		Left Stool Leg	2
C		Right Stool Leg	2
D		Short Stretcher	2
E		Long Stretcher	2

Hardware

Label	Picture	Description	QTY
①		Bolt (M8x60mm)	5
②		Screw (M4x45mm)	9
③		Spring Washer	5
④		Washer	5
⑤		Allen Wrench	1
⑥		Screwdriver (Not provided)	1

Assembly Preparation

Before Beginning Assembly:

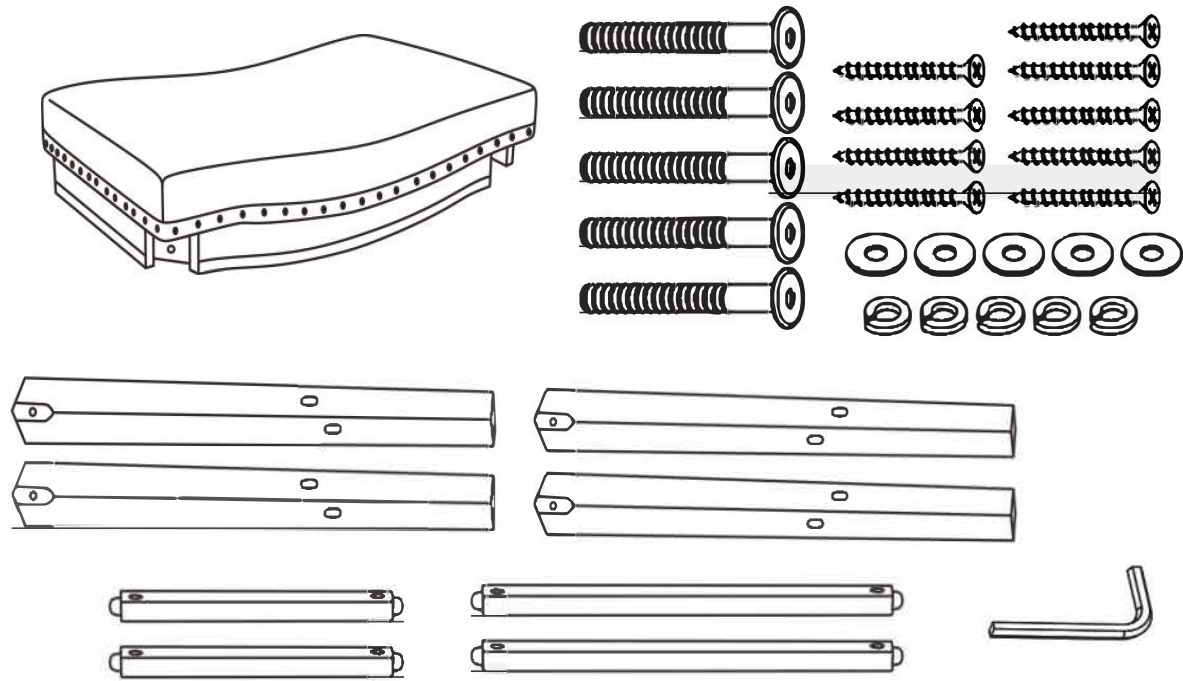

- Read instructions, cover to cover-



- Have 2 adults on hand for assembly-



- Do not assemble on flooring or carpet-



- Assemble on a clean non-marring surface (packing foam)-



- Save all packaging until finished-

Assembly Steps

Overview

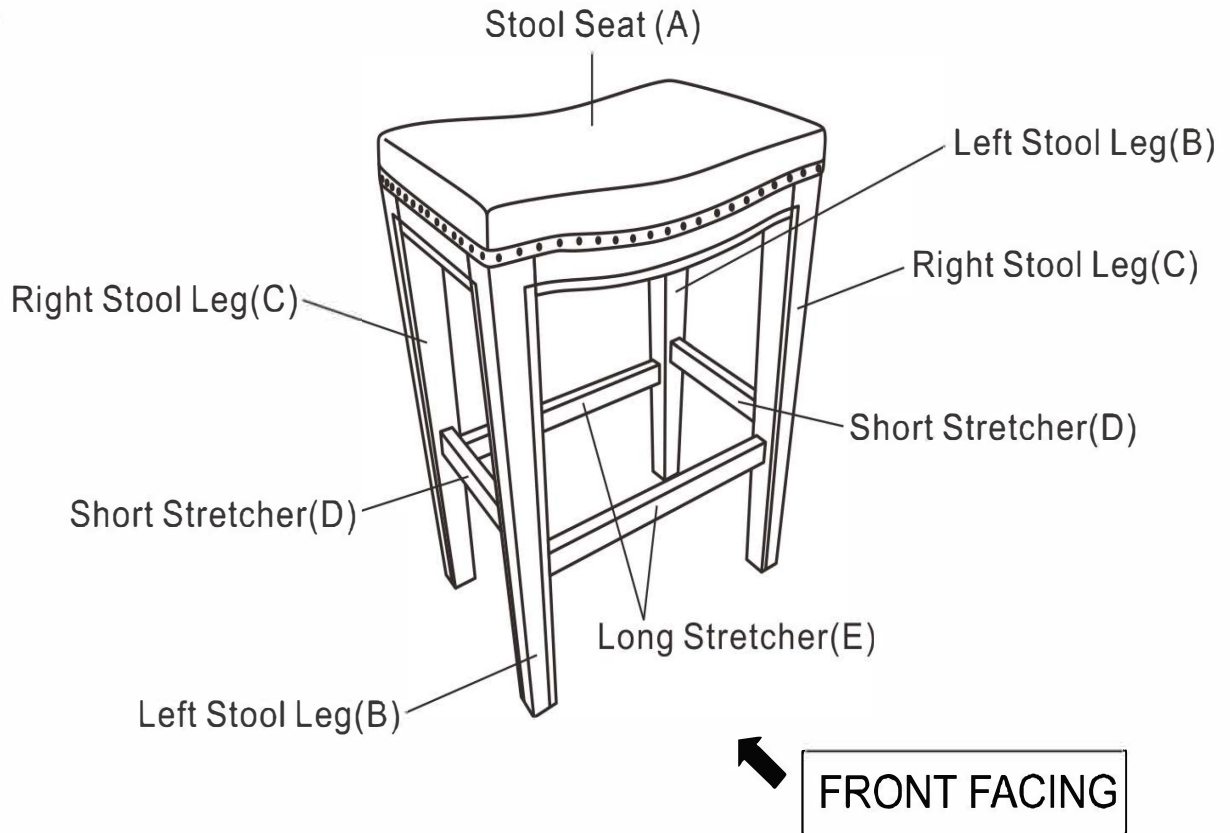

This Stool has multiple parts and may require up to 30 minutes to assemble. To give you an overview of the Stool parts, the above picture is provided to help you put the various parts into perspective. Please read through the instructions below to familiarise yourself with the parts and steps before assembly.

Step 1

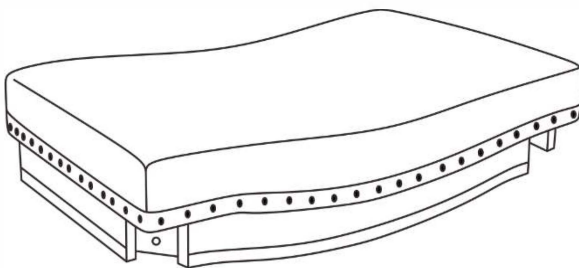

A. Stool Seat

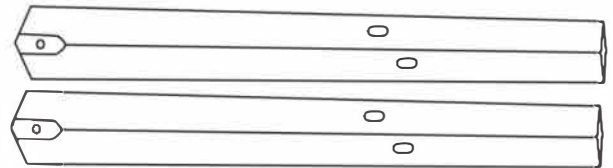

B. Left Stool Leg

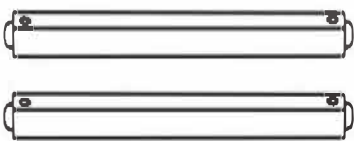

E. Long Stretcher

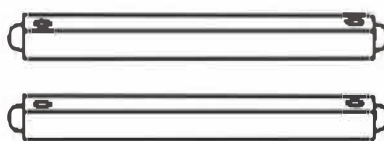

D. Short Stretcher

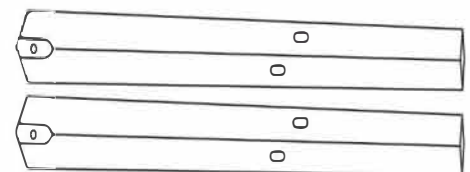

C. Right Stool Leg

Place the Stool Seat(A), the Left Stool Legs(B), the Right Stool Leg(C), the Short Stretchers(D) and the Long Stretchers(E) onto a clean, non-marring surface.

Step 2

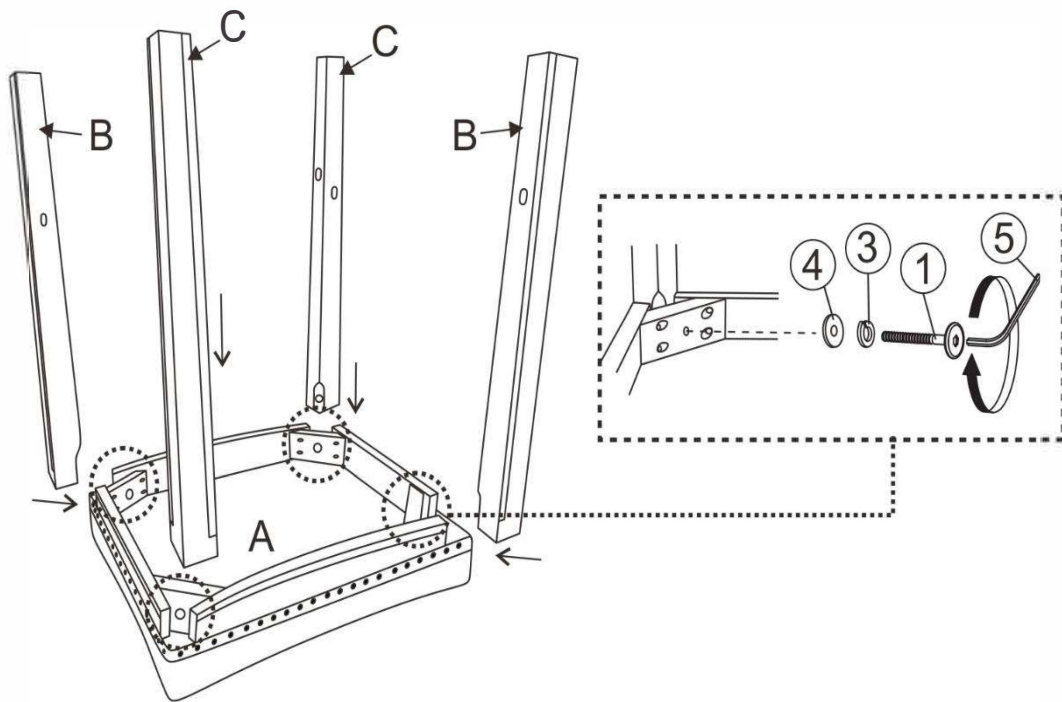

Attach the Left Stool Legs(B) and Right Stool Legs(C) to the Stool Seat(A) , using Bolts(①), Spring Washers(③), Washers(④) and the Allen Wrench(⑤).

Do not fully tighten the bolts at this time.

Step 3

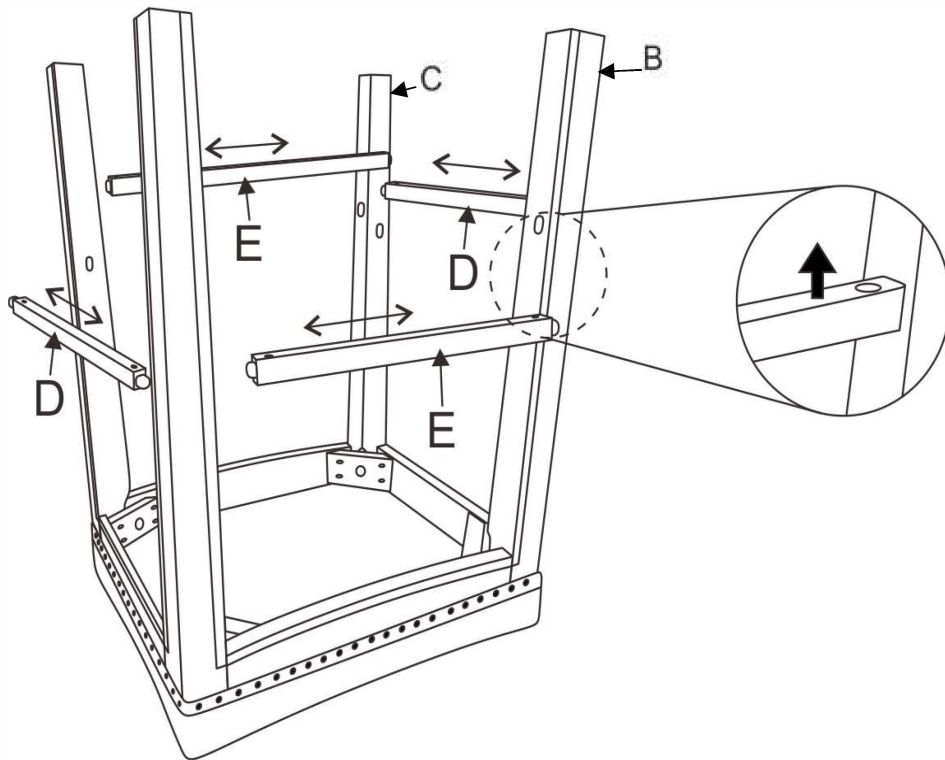

Insert the Short Stretchers(D) and Long Stretchers(E) into the mounting positions between the legs in sequence.

Note: You may need to apply a little pressure to the Stool Legs to enable the Stretcher to be slotted into position.

Please ensure that all the drill holes on the Stretcher are facing upwards as shown in the figure.

Step 4

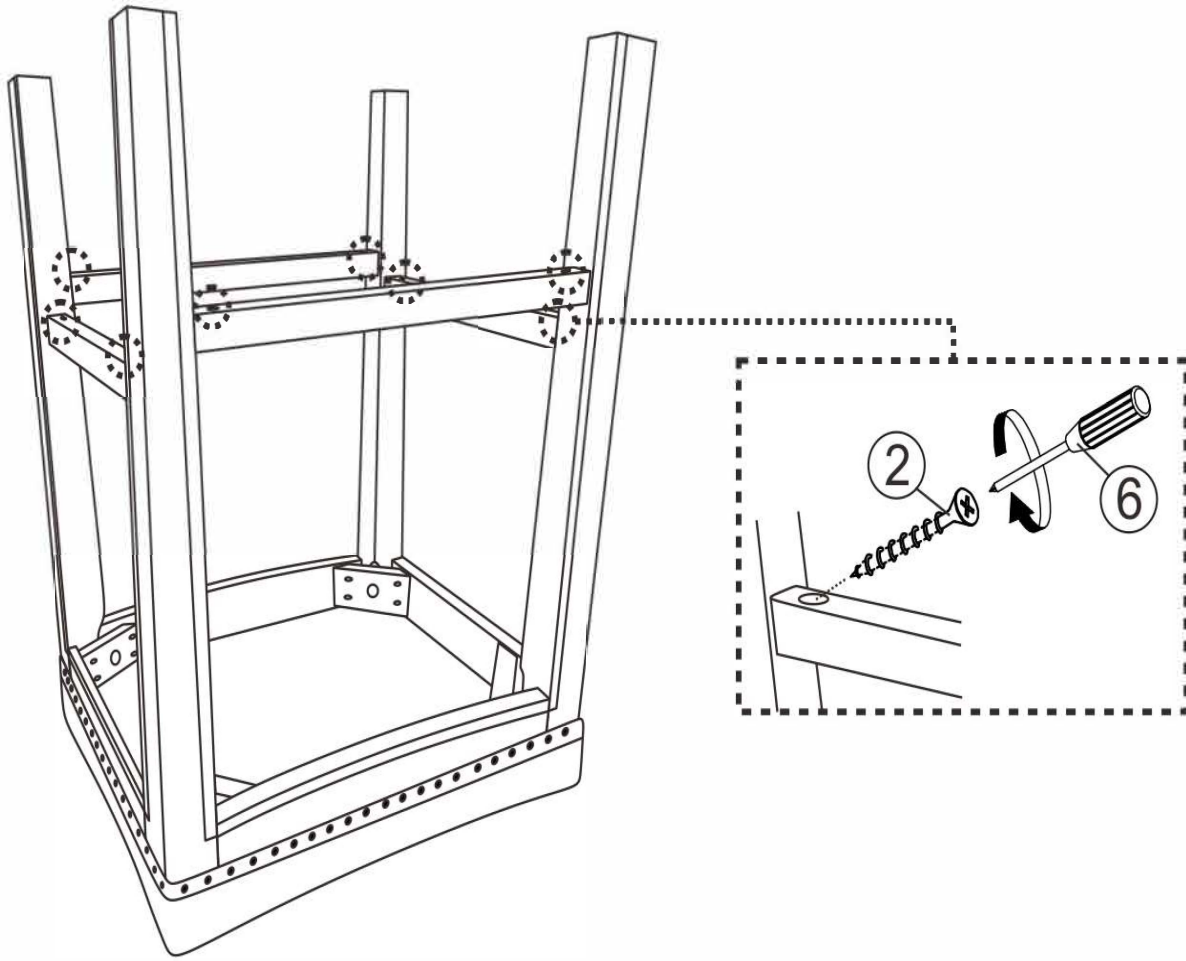

Attach all Stretchers using Screws(②) and a Screwdriver(⑥).

Step 5

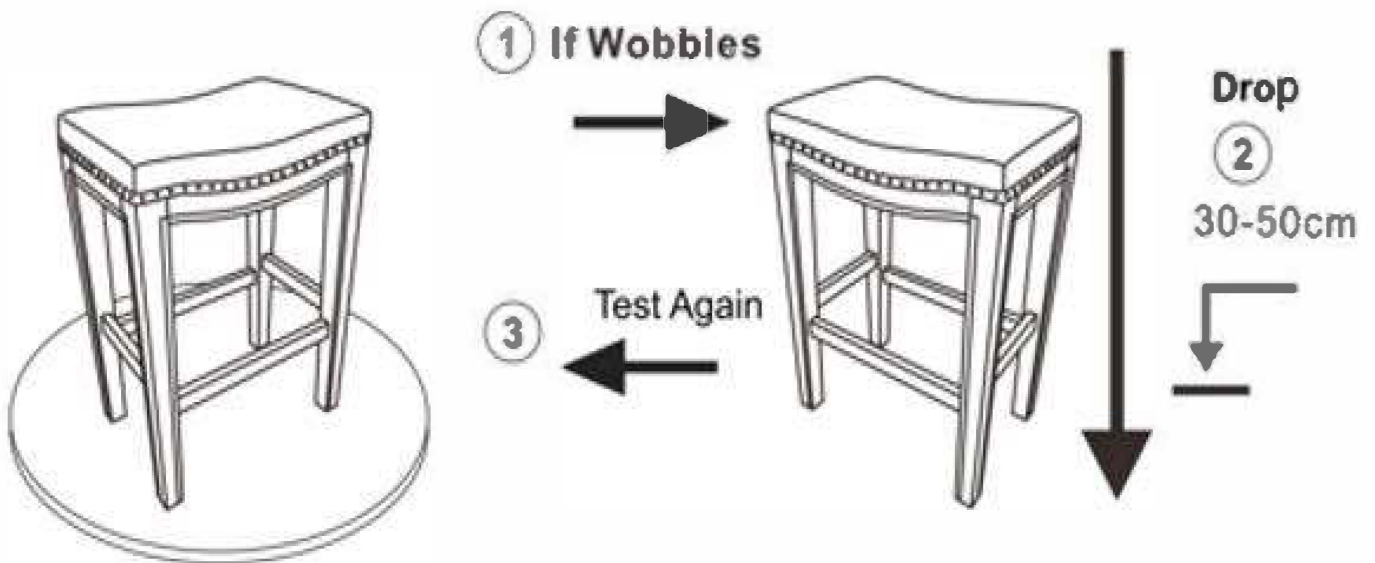

Place the Stool on a Level Surface to check if it wobbles.

If it wobbles, lift the Stool up some 30cm to 50cm from the ground, keep your feet and toes well away from the drop zone, and drop the Stool freely and vertically with the four legs, hitting the ground at the same time.

This Drop Test will help ensure that all parts and gaps reach full alignment. Test again for evenness on a Level Surface.

If no wobbles are found, proceed to tighten all the Bolts.

When tightening the Bolts, tighten sequentially.

Do not tighten any Bolt fully and then move on to the next one, as this could cause the frame to warp. Rather in a sequential manner, gradually tighten each Bolt until all are evenly secured. This methodology will ensure maximum evenness once all Bolts are fully tightened.

If the Stool still wobbles, loosen the Bolts and execute the same drop test, then proceed to tighten the bolts again in a sequential manner.

Step 6

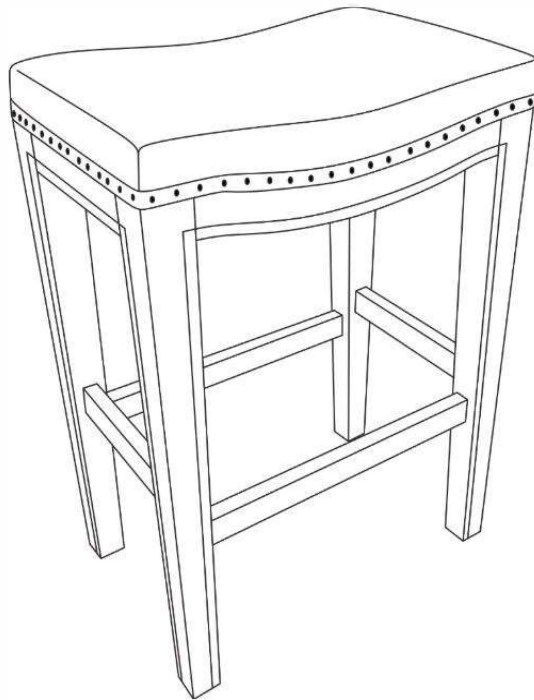

Your Stool is now ready for use.

This Stool can only be used on a flat, level surface.

Care & Maintenance



- Furniture may scratch floors. We recommend using furniture pads to protect your floors.



- Do not put hot items directly on furniture surface.



- Do not clean furniture with harsh cleansers or polish.



- Do not place furniture under direct sunlight.



- Do not place furniture near heating or cooling vents.



- Do not write on furniture without a padded barrier to protect the surface.



- Do not place furniture outside . For indoor use only.



- Not for commercial use. For residential use only.



- Stains may be removed with mild soap solution and damp cloth.



- Children should not climb or jump on the furniture.



- Dust and pick-up spills using a clean, non-colored, lint-free cloth.