













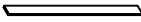

CARE AND MAINTENANCE

Spot clean using a mild water-free solvent. Only a professional cleaner should undertake a complete overall cleaning.
The use of steam or water-based cleaners may cause excessive shrinking or staining.

NOTICE

- * Please make sure that you have all parts indicated before you begin assembly of this item.
- * This item should be assembled on a soft surface to prevent scratching the finish during assembly.
- * This item may require periodic tightening.

Part List and Hardware List

PIECE	DESCRIPTION	PICTURE	QTY	CARTON CALL
A	HEADBOARD		1X	1 OF 2
B	LEFT LEG		1X	1 OF 2
C	RIGHT LEG		1X	1 OF 2
D	STRETCHER		1X	1 OF 2
E	FOOTBOARD		1X	1 OF 2
F	SIDE RAIL		2X	2 OF 2
G	SLAT		4X	2 OF 2
H	CENTER LEG		8X	2 OF 2
1	80 MM THREADED ROD	5/16"x80mm 	16X	1 OF 2
2	SQUARE WASHER		10X	1 OF 2
3	FLAT WASHER		6X	1 OF 2
4	HEX NUT		16X	1 OF 2
5	HEX WRENCH		1X	1 OF 2
6	1" ROUND HEAD SCREW	M4x25mm 	16X	1 OF 2
7	LARGE DOWEL		4X	1 OF 2
8	SMALL DOWEL		4X	1 OF 2

SAFAVIEH

COOUTURE

Model# SFV1300-K

Product Dimensions: 79 7/8"W x 85 9/16"D x 46 11/16"H

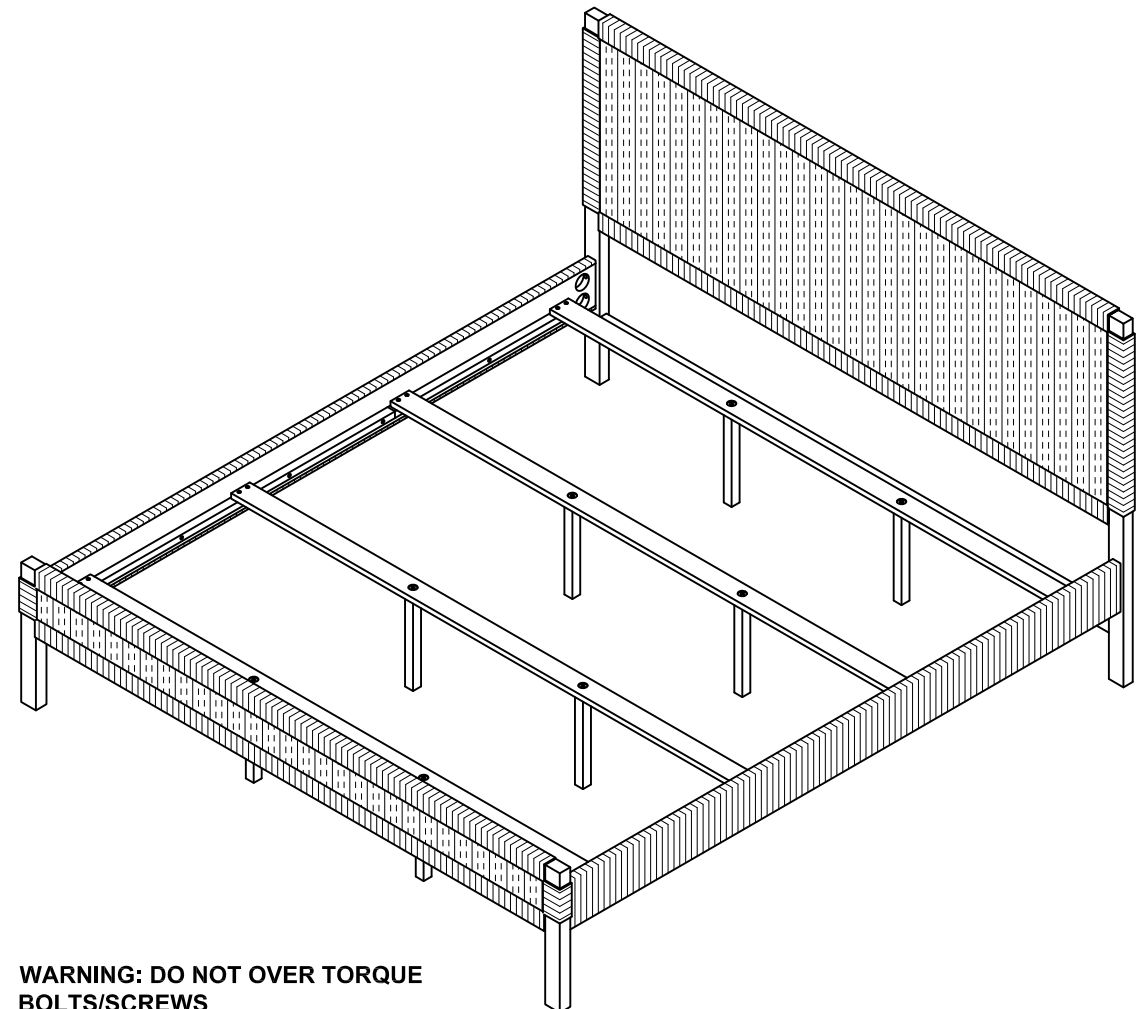

WARNING: DO NOT OVER TORQUE BOLTS/SCREWS

PREPARATION

Before beginning assembly of product, make sure all parts are present. Compare parts with package contents list and hardware contents list.

If any part is missing or damaged, do not attempt to assemble the product.

Estimated Assembly Time: 60 minutes.

Tools Required for Assembly : Phillips Screwdriver

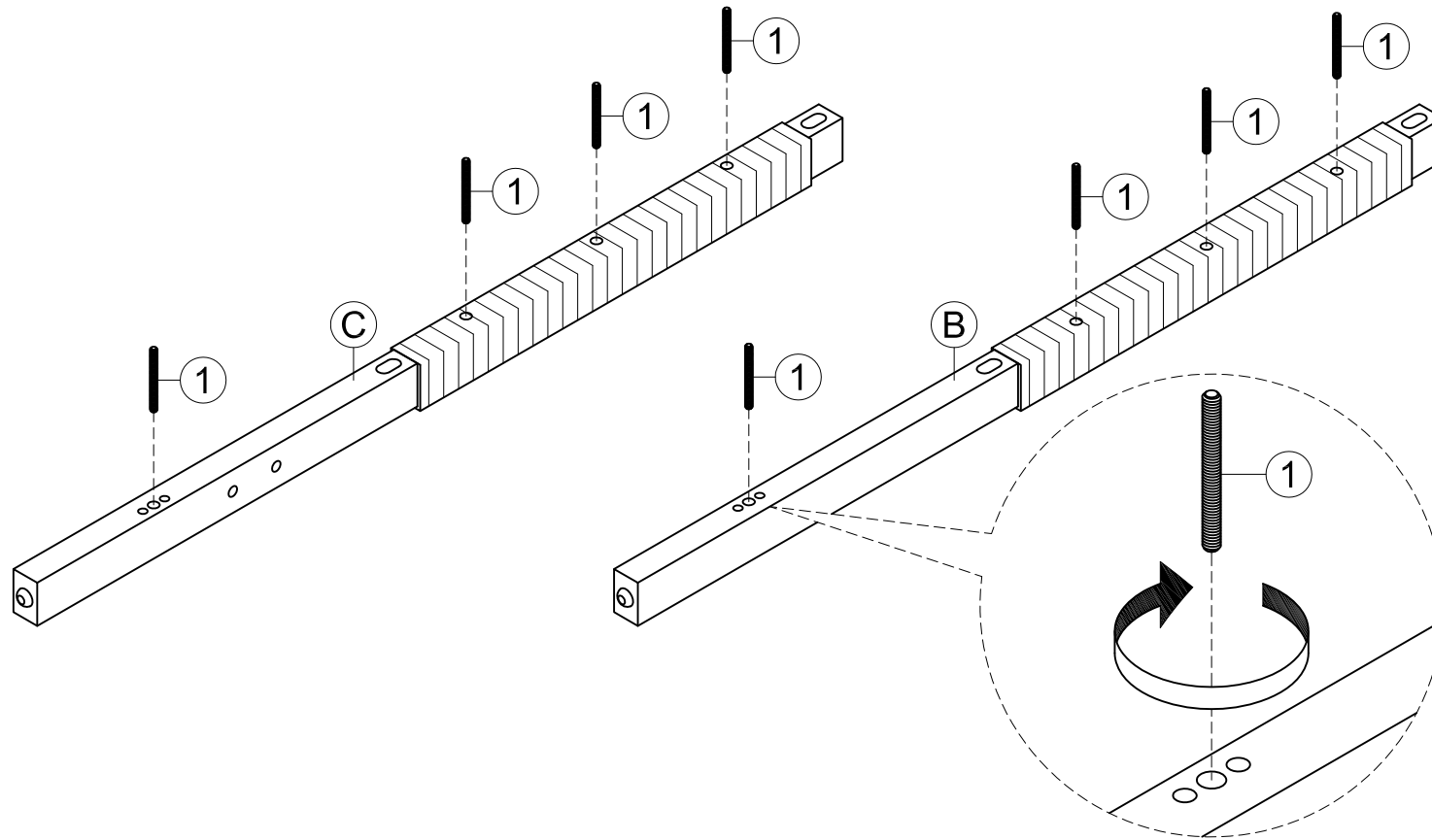

STEP 1 SCREW IN THREADED RODS (PART 1) TO THE LEFT AND RIGHT LEGS (PART B AND C). THEN TIGHTEN THE RODS.

PREPARATION

Before beginning assembly of product, make sure all parts are present. Compare parts with package contents list and hardware contents list.

If any part is missing or damaged, do not attempt to assemble the product.

Estimated Assembly Time: 60 minutes.

Tools Required for Assembly : Phillips Screwdriver

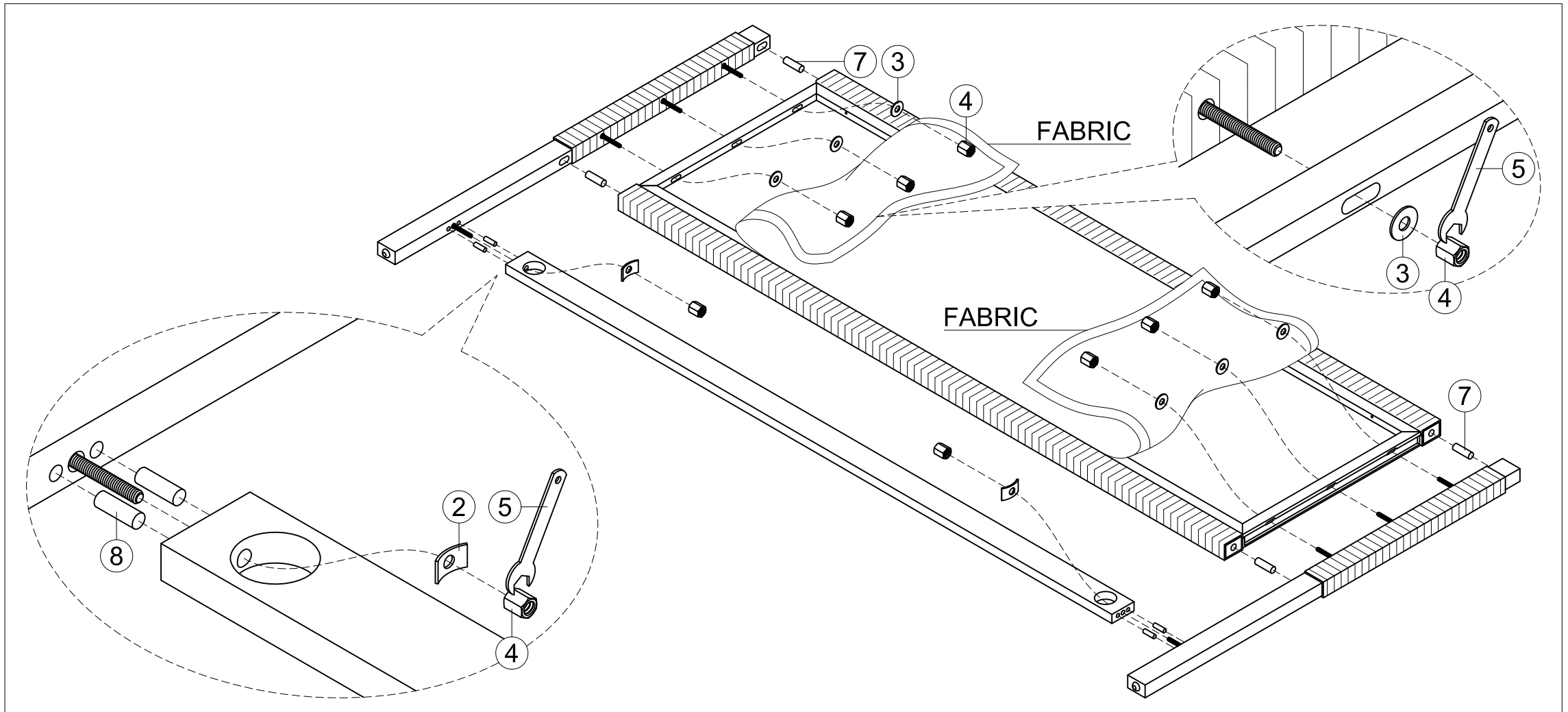

STEP 2 UNCOVER THE FABRIC ON BOTH ENDS OF THE BACK OF THE HEADBOARD (PART A). ATTACH LEFT AND RIGHT LEGS (PART B AND C) TO THE HEADBOARD WITH THE LARGE DOWELS (PART 7). USE THE FLAT WASHERS (PART 3) AND HEX NUTS (PART 4) TO ATTACH THE LEGS TO THE HEADBOARD. ATTACH THE STRETCHER (PART D) TO THE HEADBOARD LEGS WITH THE DOWELS (PART 8). USE THE SQUARE WASHERS (PART 2) AND THE HEX NUTS (PART 4) TO ATTACH THE STRETCHER TO THE HEADBOARD LEGS. TIGHTEN THE NUTS USING THE HEX WRENCH (PART 5). PLACE THE FABRIC BACK INTO PLACE. **NOTE: ASSEMBLE HEADBOARD (PART A) AND STRETCHER (PART D) AT THE SAME TIME.**

PREPARATION

Before beginning assembly of product, make sure all parts are present. Compare parts with package contents list and hardware contents list.

If any part is missing or damaged, do not attempt to assemble the product.

Estimated Assembly Time: 60 minutes.

Tools Required for Assembly : Phillips Screwdriver

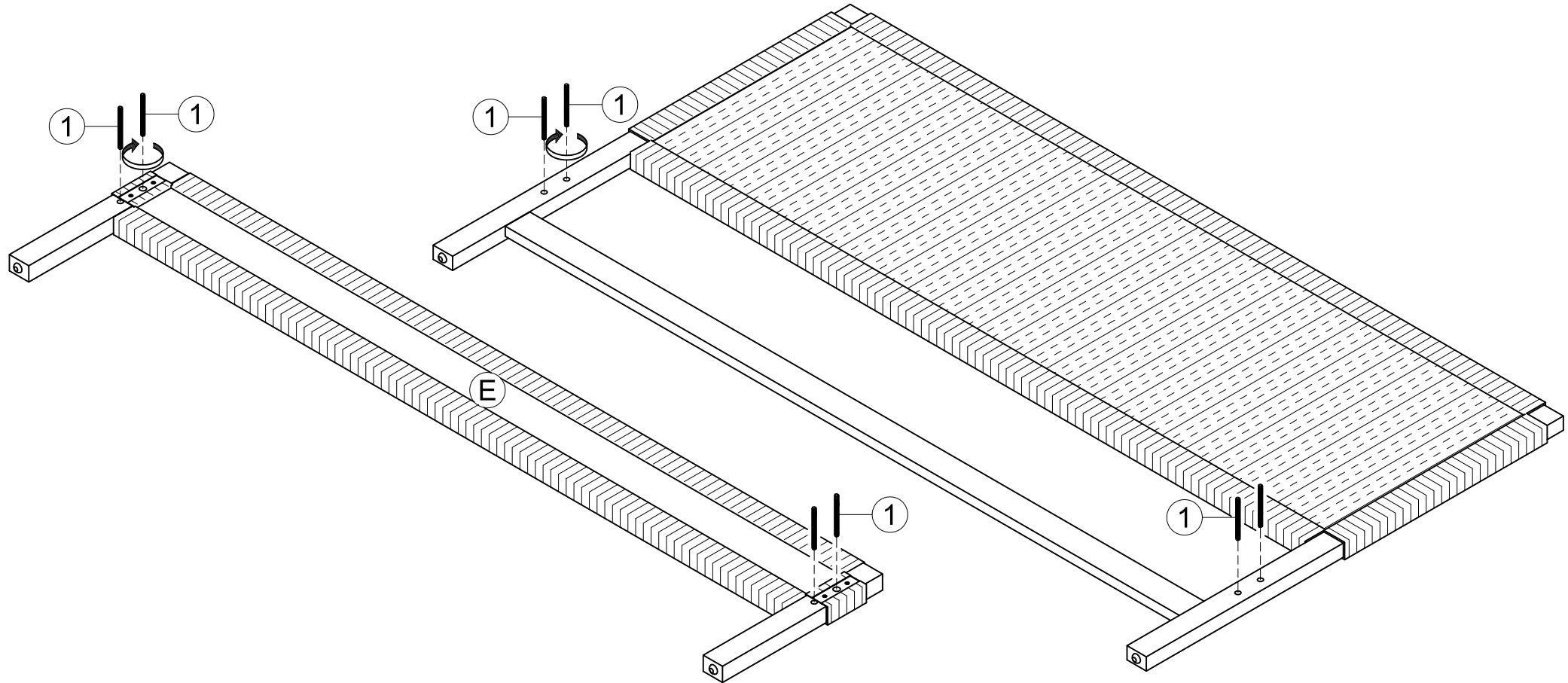

STEP 3 ATTACH THREADED RODS TO THE HEADBOARD LEGS AND FOOTBOARD (PART E). TIGHTEN THE RODS.

PREPARATION

Before beginning assembly of product, make sure all parts are present. Compare parts with package contents list and hardware contents list.

If any part is missing or damaged, do not attempt to assemble the product.

Estimated Assembly Time: 60 minutes.

Tools Required for Assembly : Phillips Screwdriver

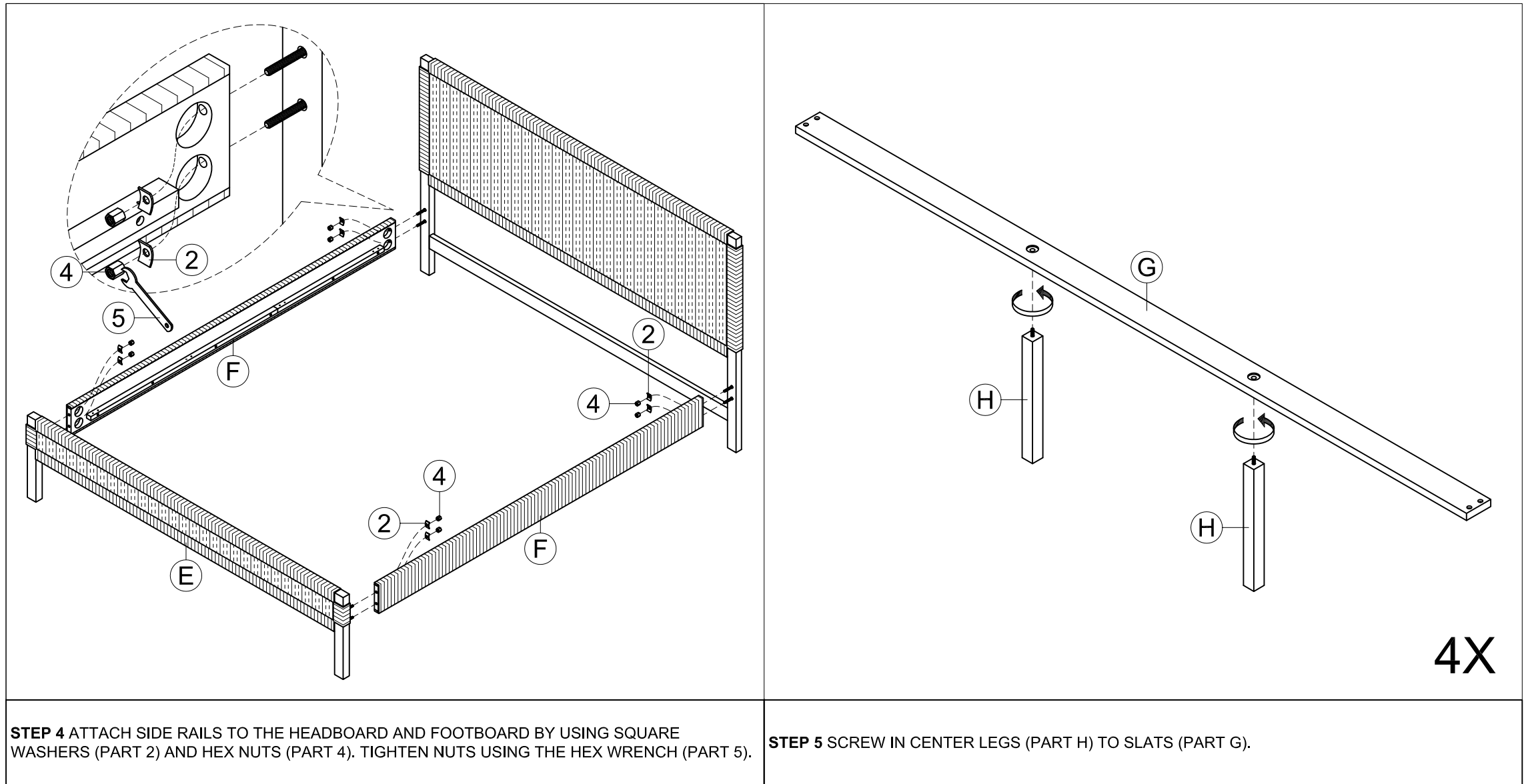

STEP 4 ATTACH SIDE RAILS TO THE HEADBOARD AND FOOTBOARD BY USING SQUARE WASHERS (PART 2) AND HEX NUTS (PART 4). TIGHTEN NUTS USING THE HEX WRENCH (PART 5).

STEP 5 SCREW IN CENTER LEGS (PART H) TO SLATS (PART G).

PREPARATION

Before beginning assembly of product, make sure all parts are present. Compare parts with package contents list and hardware contents list.

If any part is missing or damaged, do not attempt to assemble the product.

Estimated Assembly Time: 60 minutes.

Tools Required for Assembly : Phillips Screwdriver

