

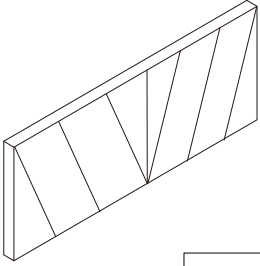

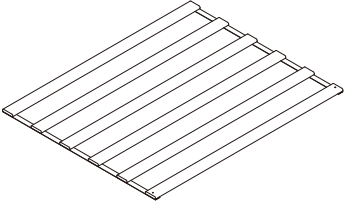

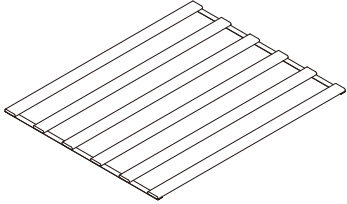

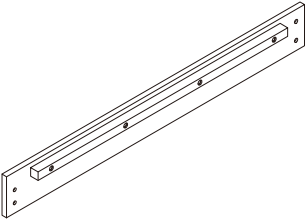

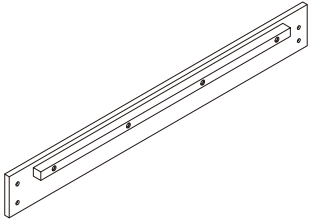

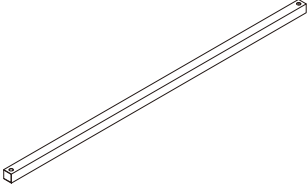
<p>1</p>  <p>1PC</p>	<p>2</p>  <p>1PC</p>	<p>3</p>  <p>1PC</p>
<p>4</p>  <p>2PCS</p>	<p>5</p>  <p>2PCS</p>	<p>6</p>  <p>1PC</p>
<p>7</p>  <p>1PC</p>	<p>8</p>  <p>1PC</p>	<p>9</p>  <p>1PC</p>
<p>10</p>  <p>1PC</p>	<p>11</p>  <p>2PCS</p>	<p>12</p>  <p>2PCS</p>
<p>13</p>  <p>1PC</p>	<p>14</p>  <p>2PCS</p>	

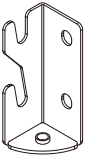
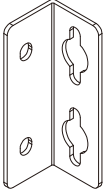
# HARDWARE LIST

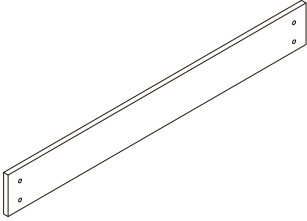
P.3

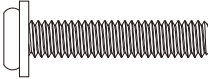
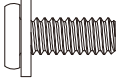
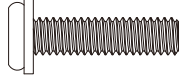
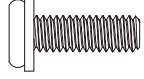
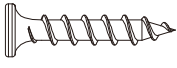
<b>A</b>  5/16x45mm    x4 +1PCS	<b>B</b>  5/16x16mm    x20+2PCS	<b>C</b>  5/16x35mm    x2+1PCS	<b>D</b>  5/16x25mm    x4+1PCS
<b>E</b>  M4x30mm    x2+1PCS	<b>F</b>  M4x100    x1PC		

1

A x 4

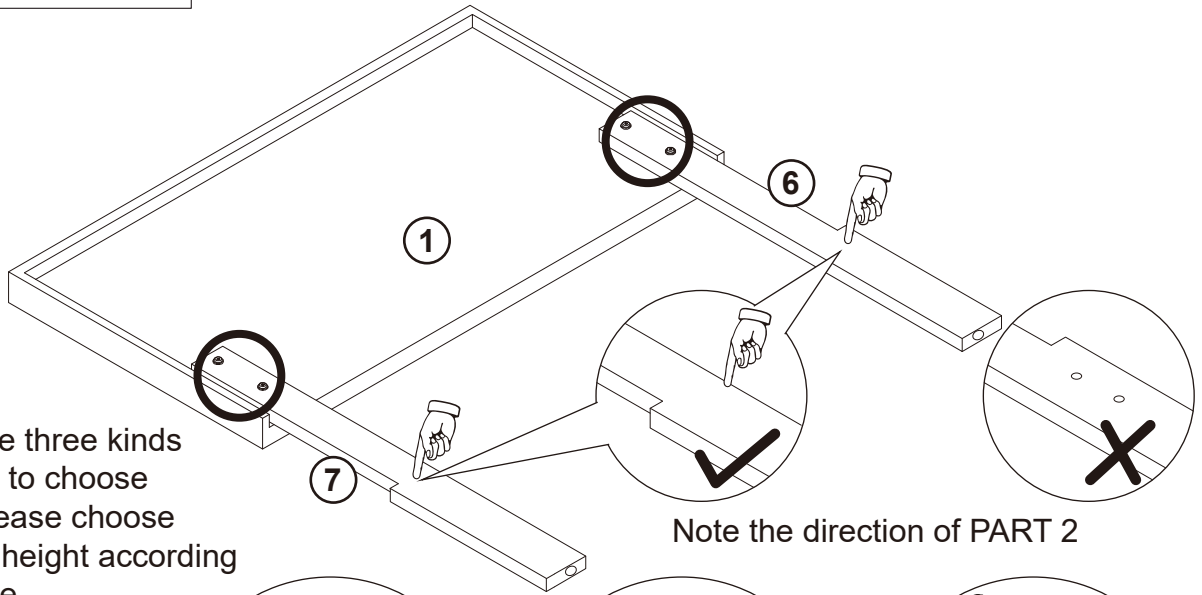

There are three kinds of height to choose from, please choose the right height according to the use.

Note the direction of PART 2

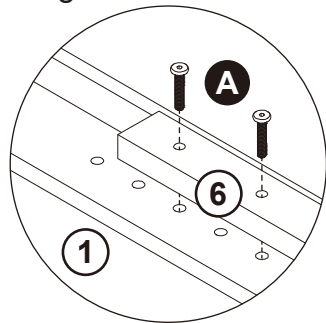

HIGH

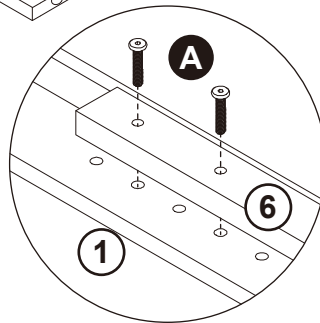

MIDDLE

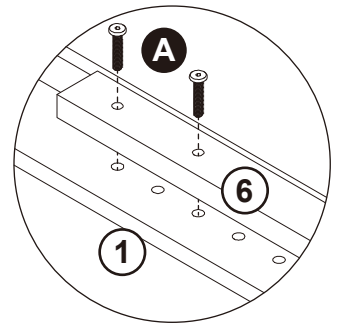

LOW

2

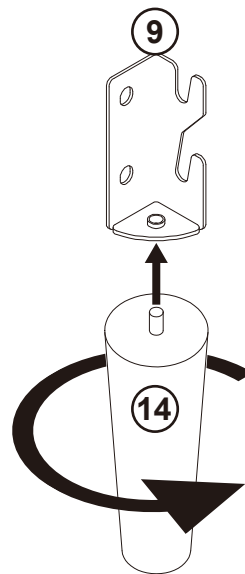
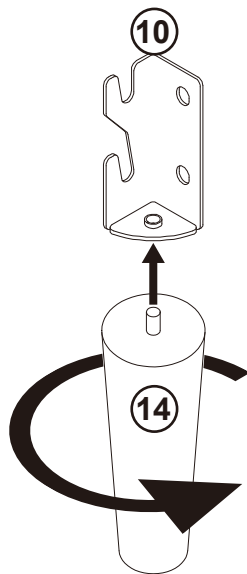

3

 B x 16

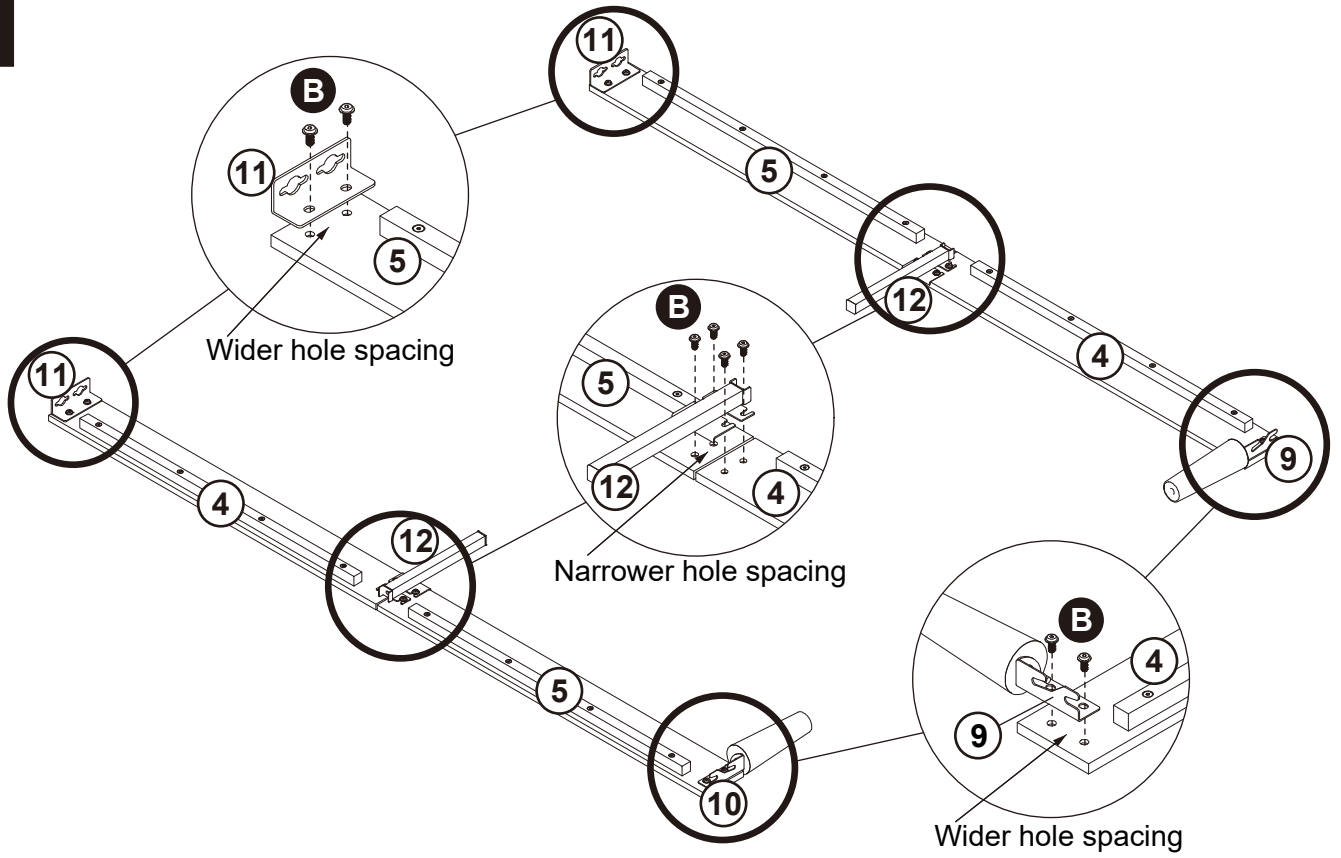

4

 B x 4

 D x 4

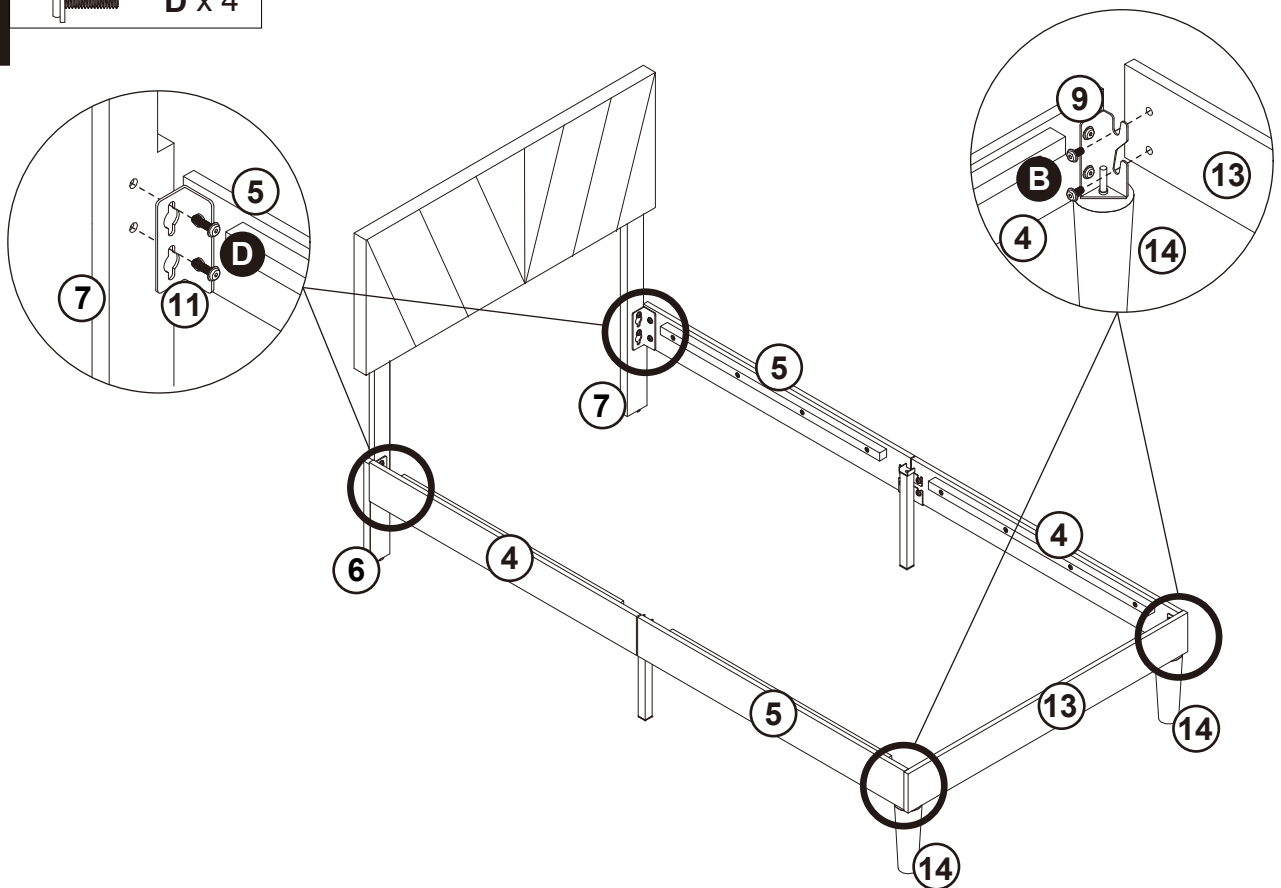

5

 C x 2

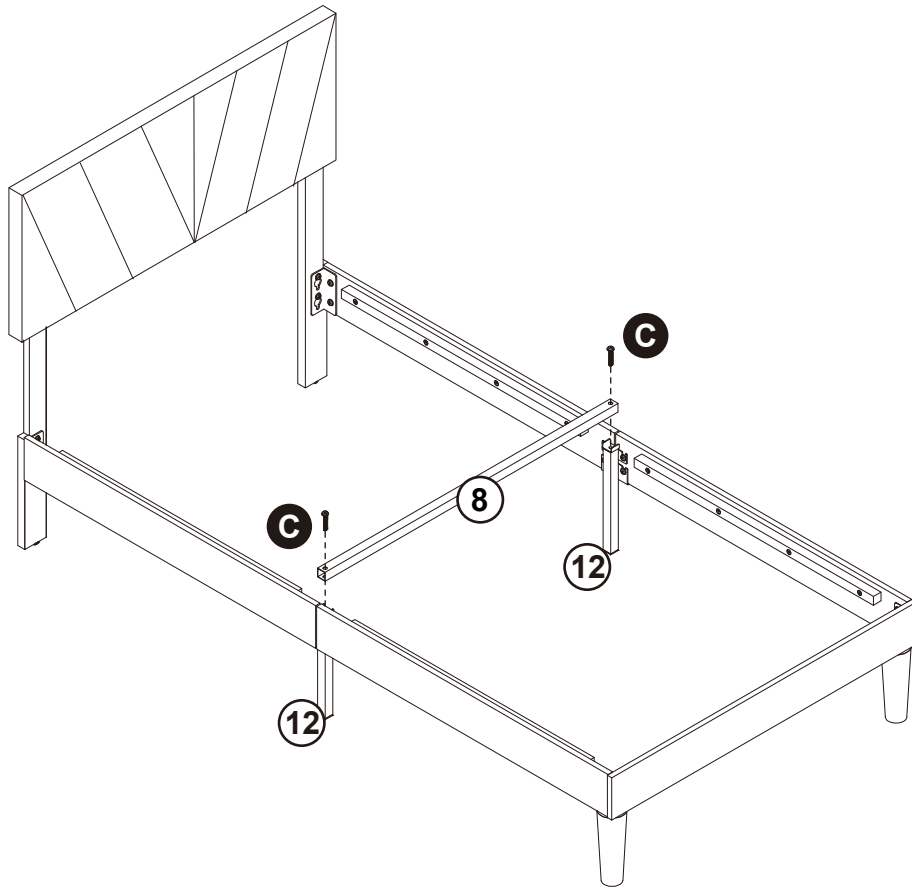

6

 E x 2

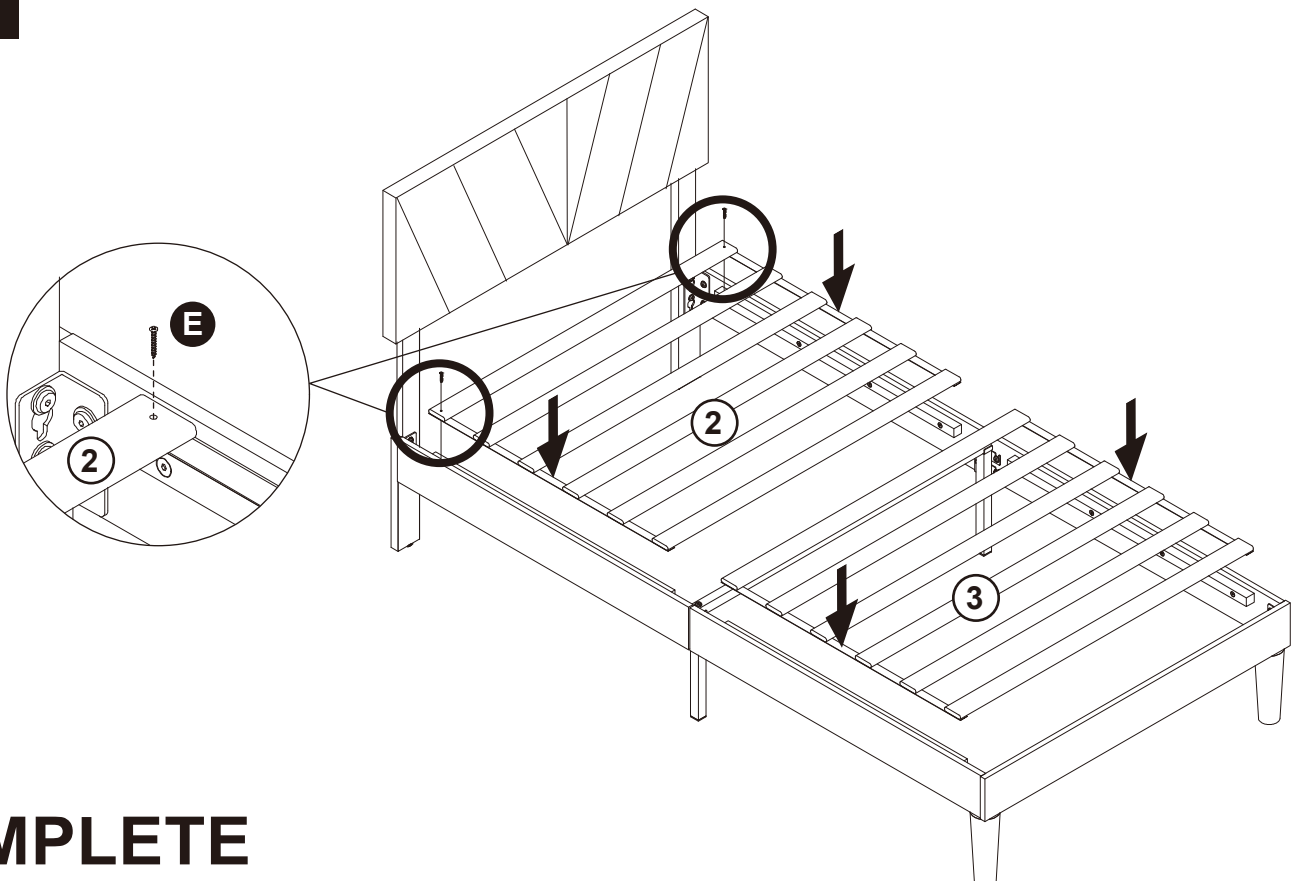

**COMPLETE**