

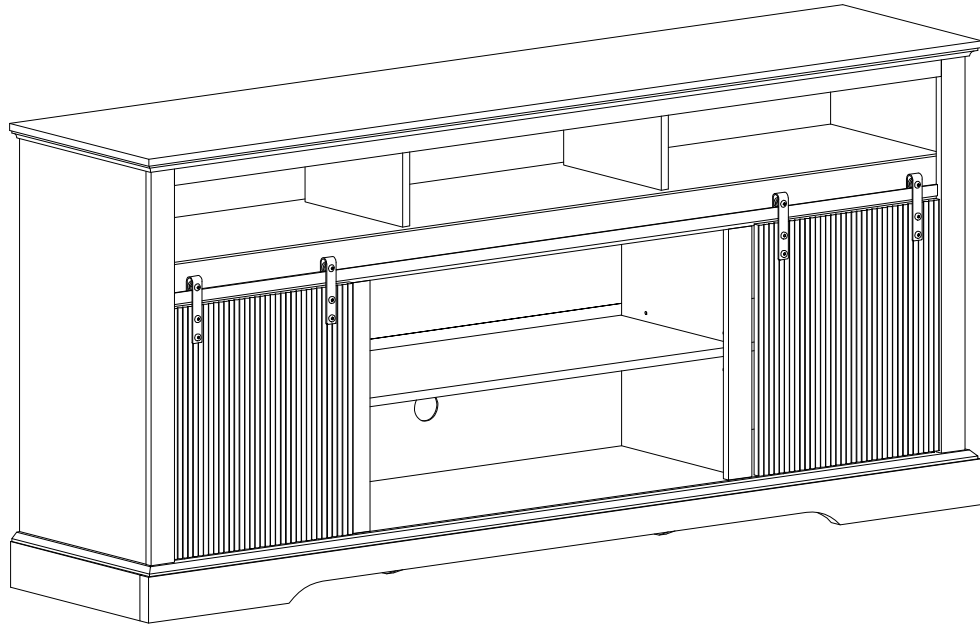

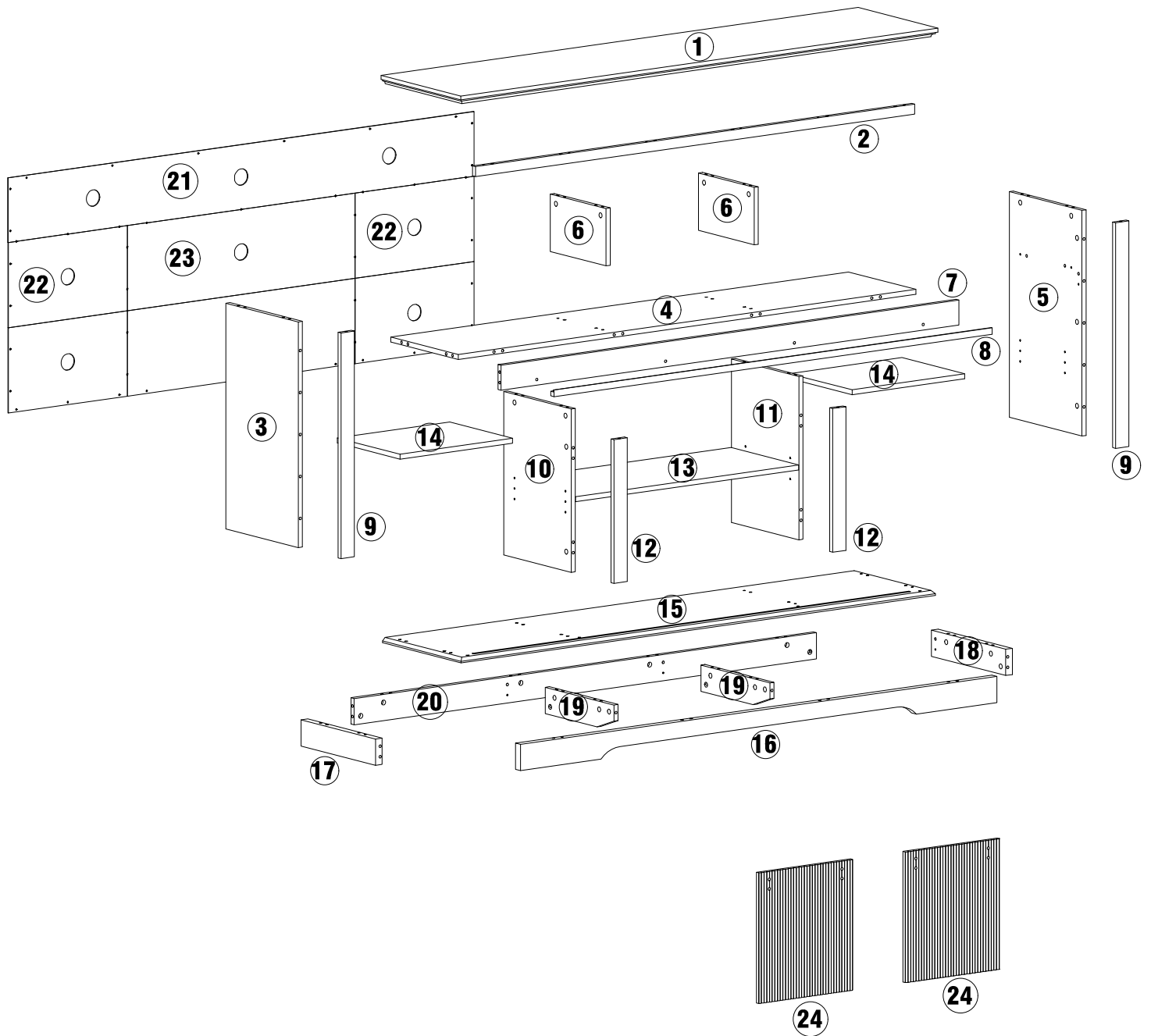



ASSEMBLY INSTRUCTIONS



PACKAGE INCLUDE

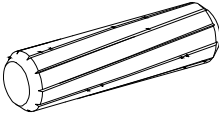
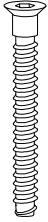
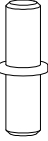

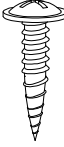
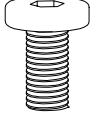
PACKAGE CONTENT

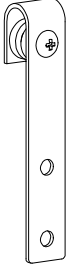
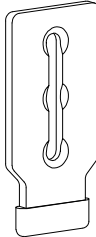
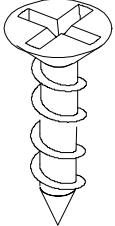
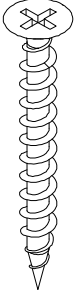
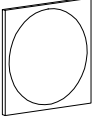
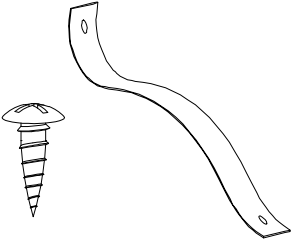
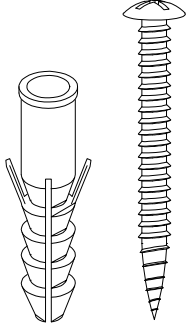
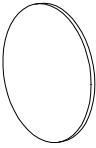
<p>Ø6x35MM</p>  <p>A 56X+2</p>	<p>Ø15x11MM</p>  <p>B 56X+2</p>	<p>Ø8x30MM</p>  <p>C 78X+2</p>	<p>Ø6x48MM</p>  <p>D 12X+1</p>
<p>Ø5x18MM</p>  <p>E 12X+1</p>	<p>4MM</p>  <p>F 1X</p>	<p>Ø3x14MM</p>  <p>G 42X+2</p>	<p>M6x12MM</p>  <p>H 8X</p>
<p>M6x25MM</p>  <p>I 4X</p>	 <p>J 4X</p>	 <p>K 4X</p>	<p>Ø4x14MM</p>  <p>L 8X</p>
<p>Ø4x35MM</p>  <p>M 6X</p>	 <p>N 8X</p>	  <p>O 2X</p>	
<p>Ø30MM</p>  <p>P 22X+1</p>			

How to use the cam lock system

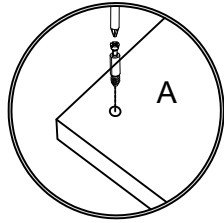

1. Screw cam bolt into panel

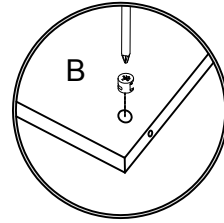

2. Push cam into panel - arrow feature on cam top points to panel edge

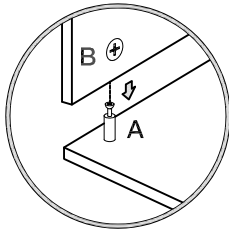

3. Align cam bolt(s) with cam(s) and insert all the way into cross-bored hole(s)

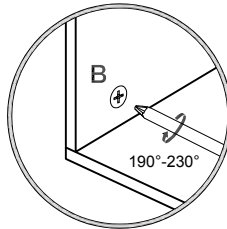

4. Rotate cam(s) clockwise 190°-230° to lock panels together

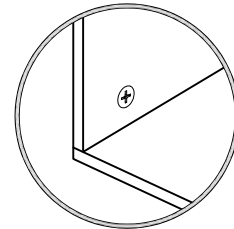

5. Panels should be tight against each other and connection should be rigid

Insert the wood dowel [C] at least half way by tapping lightly with a rubber mallet, IF NECESSARY.

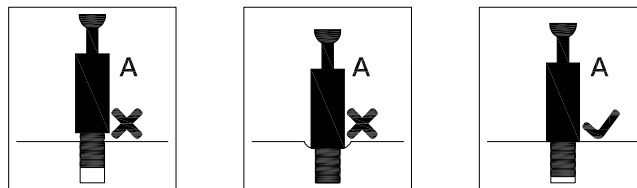
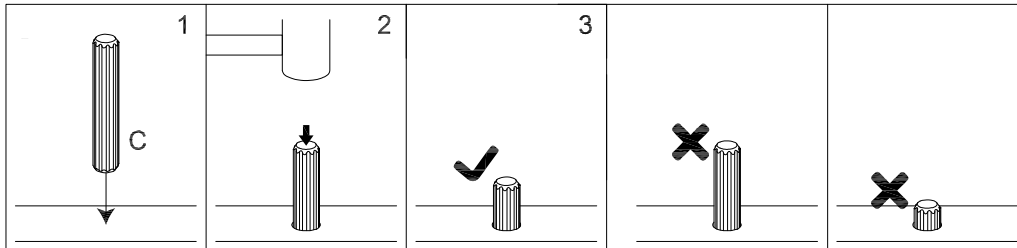

⚠ WARNING

- Unit must be placed on a level surface or leveled with included hardware (when applicable).
- Do not sit or stand on or allow children to climb, sit or stand on the assembled product.
- For safety reasons, it is imperative that this unit be mounted to the wall.
- Do not use without installing the tip restraint.
- Unit can tip over causing severe injury or death.
- Do not exceed the recommended weight limits.
- Evenly distribute the weight on each level and always keep the heavier loads on the bottom.
- Before cutting, drilling or hammering into any wall or floor surface, verify the location of electrical, plumbing and gas lines. Cutting may cause serious injury.

STEP 1

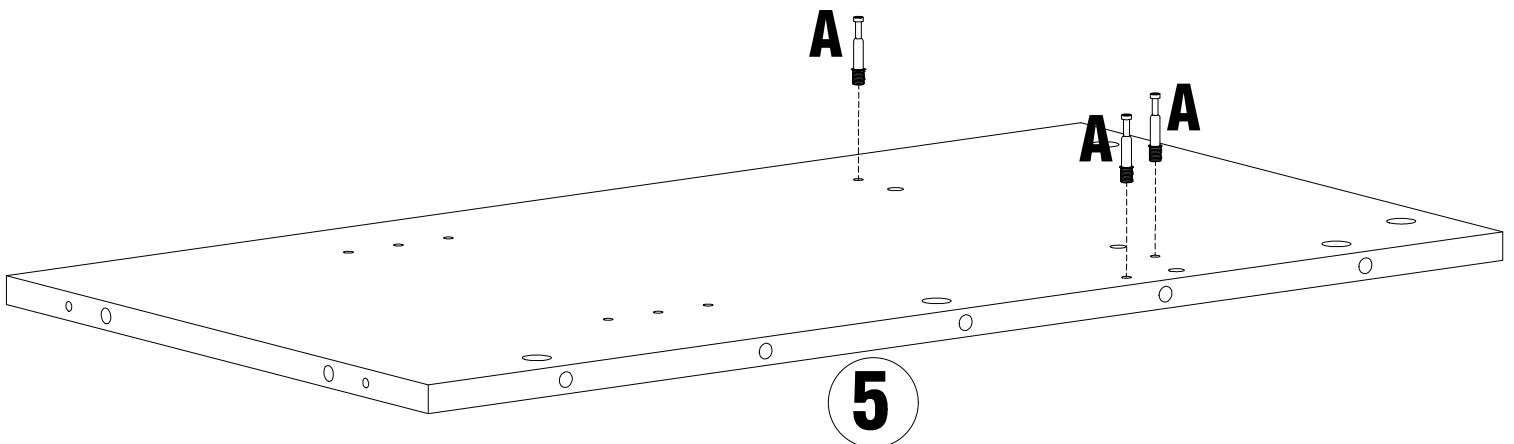
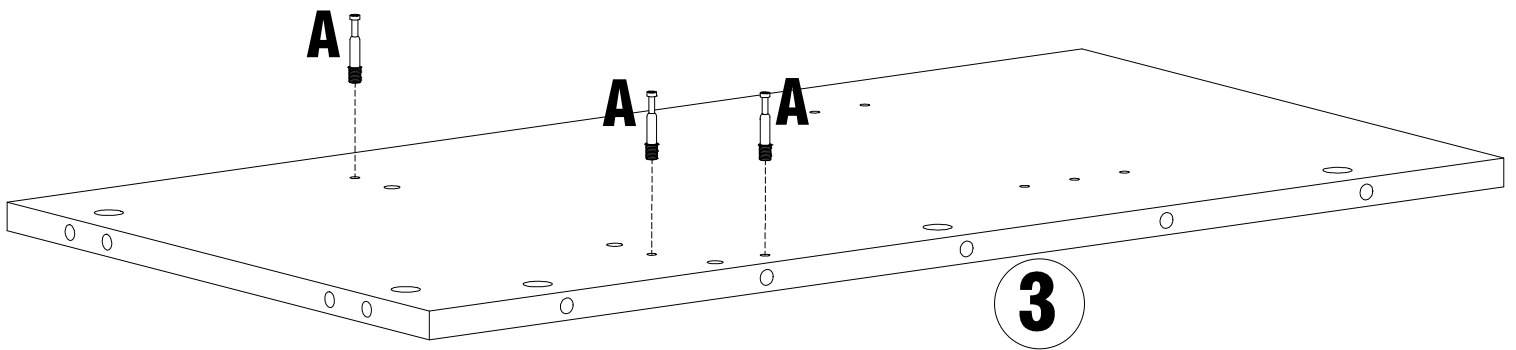
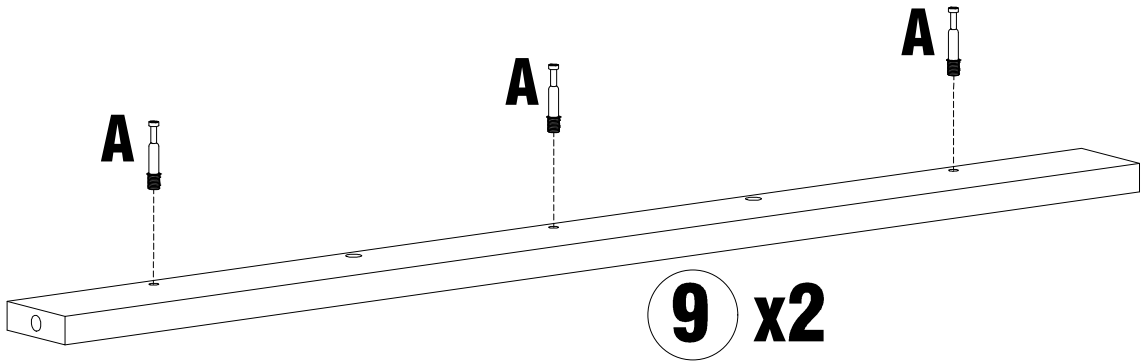
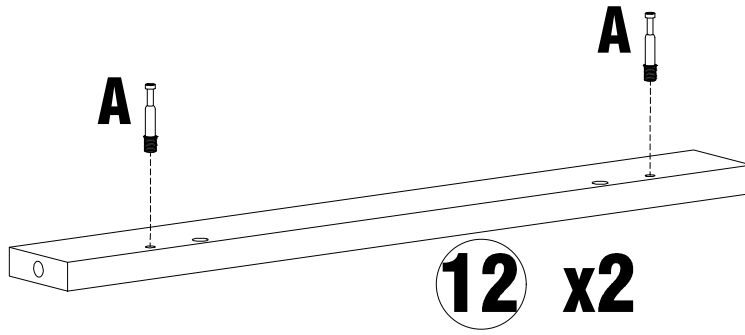
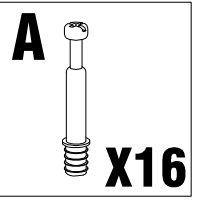

STEP 2

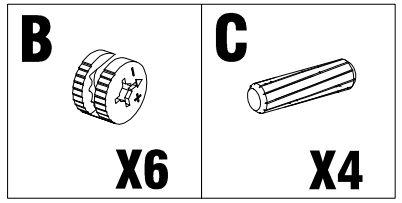
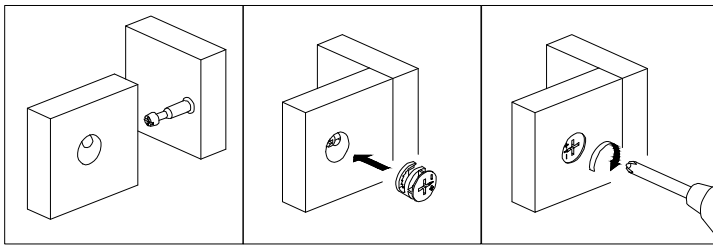

9

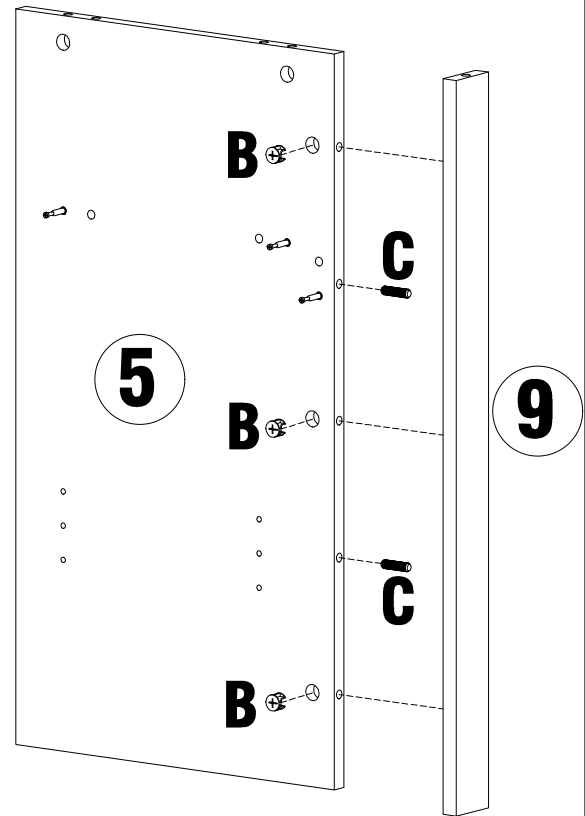
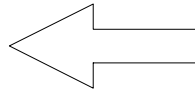
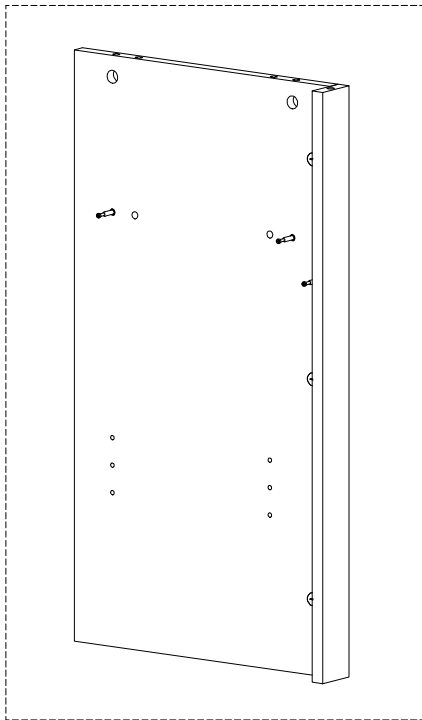
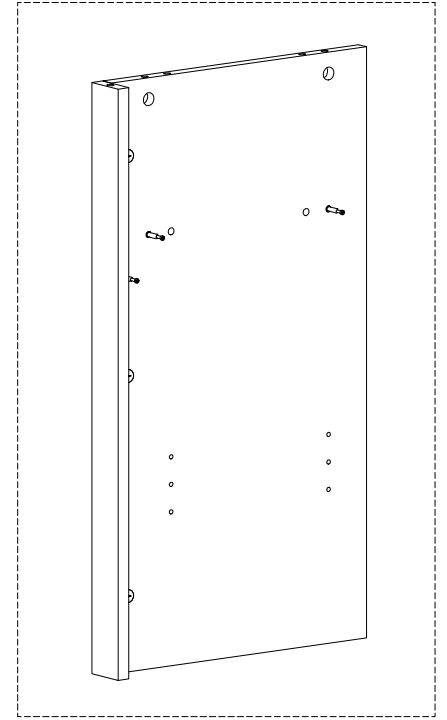
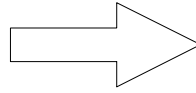
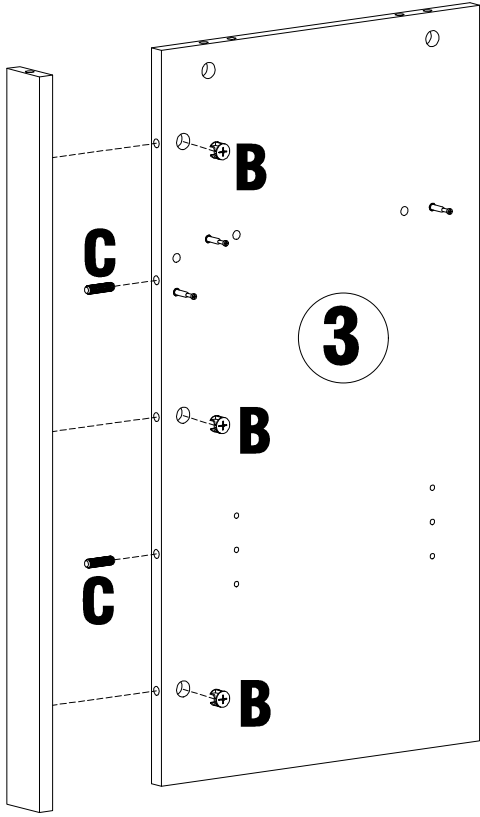

STEP 3

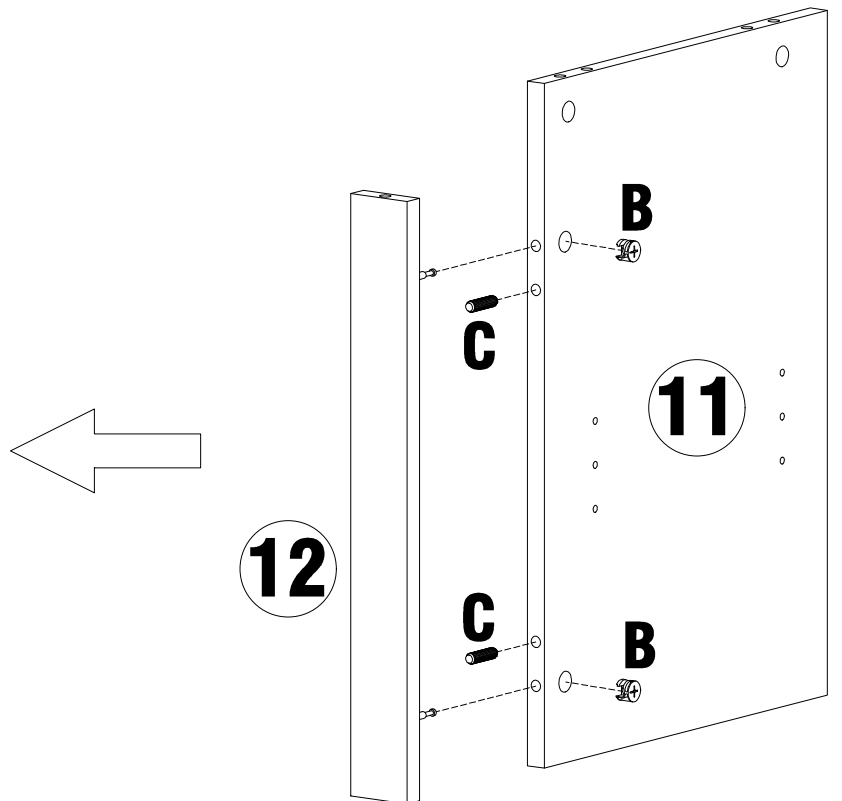
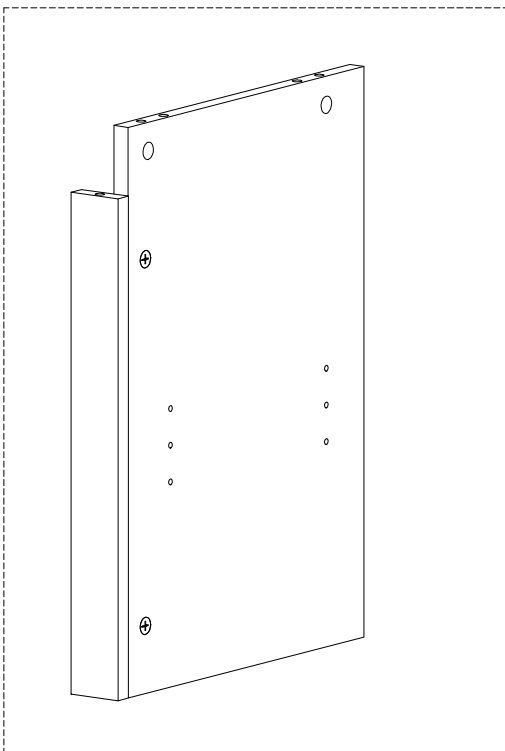
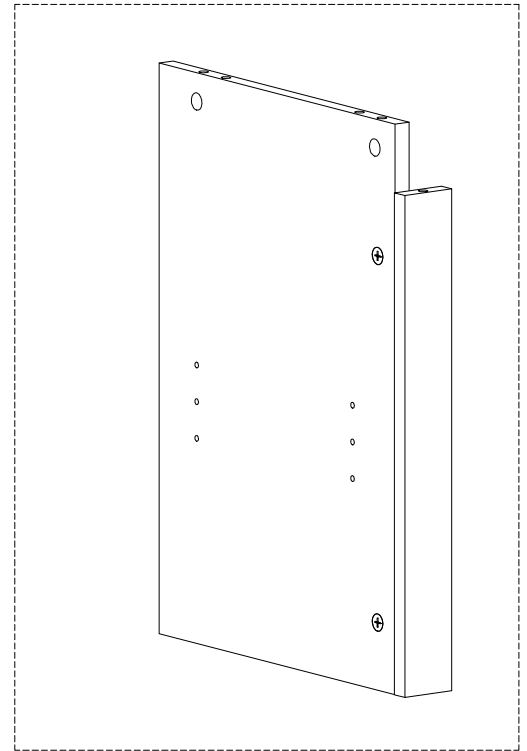
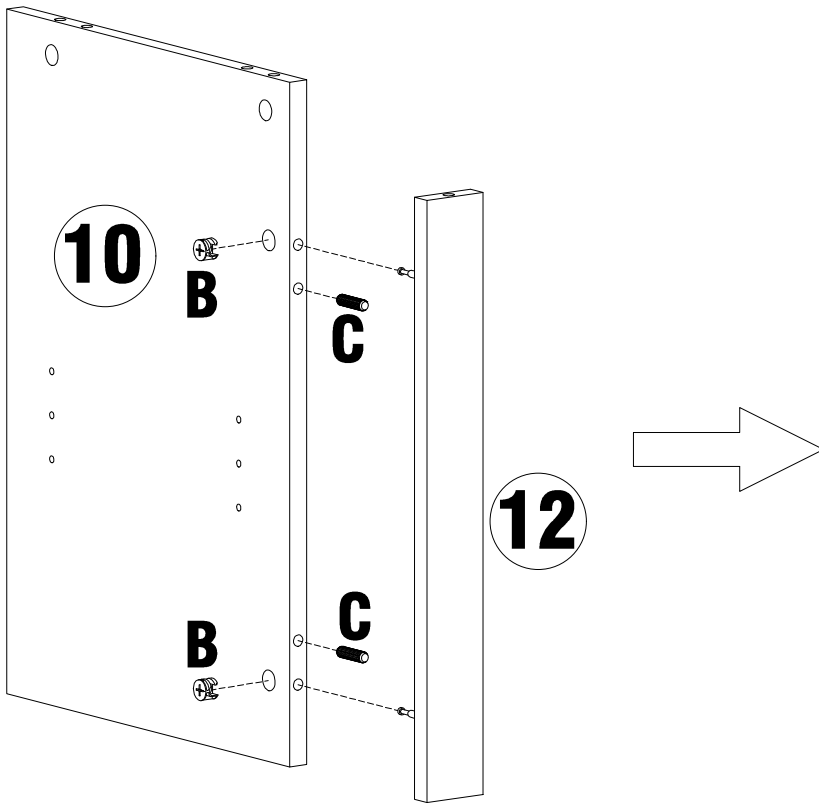
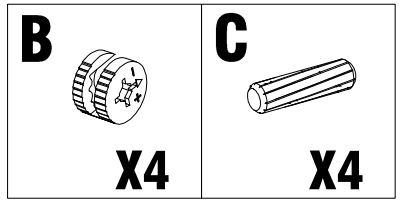

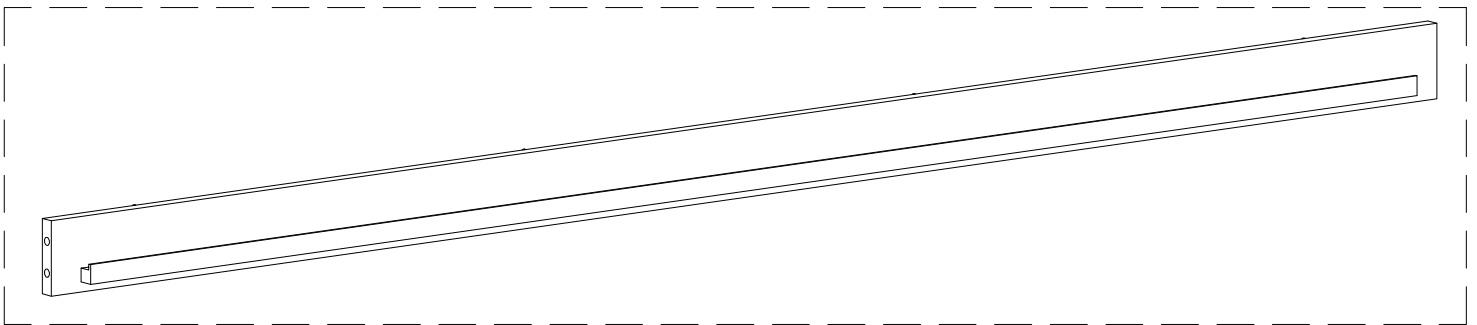
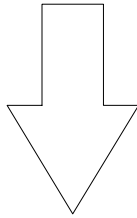
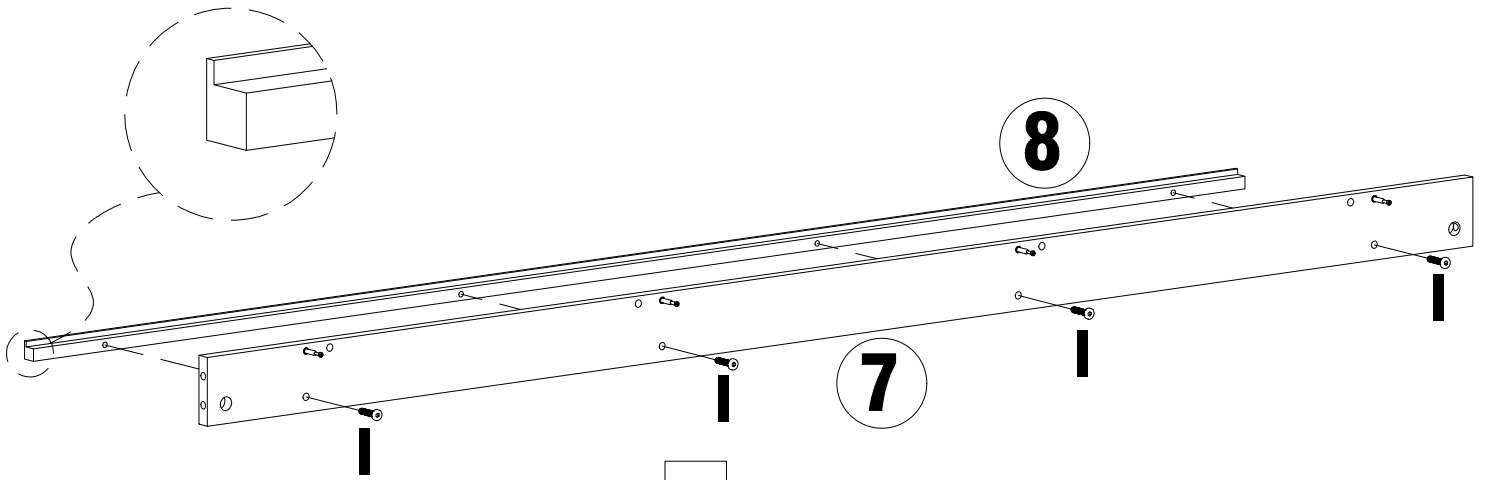
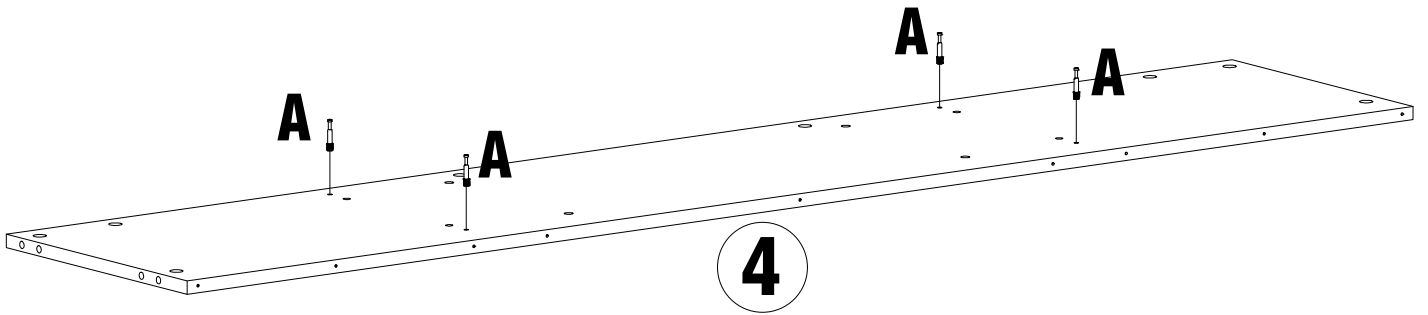
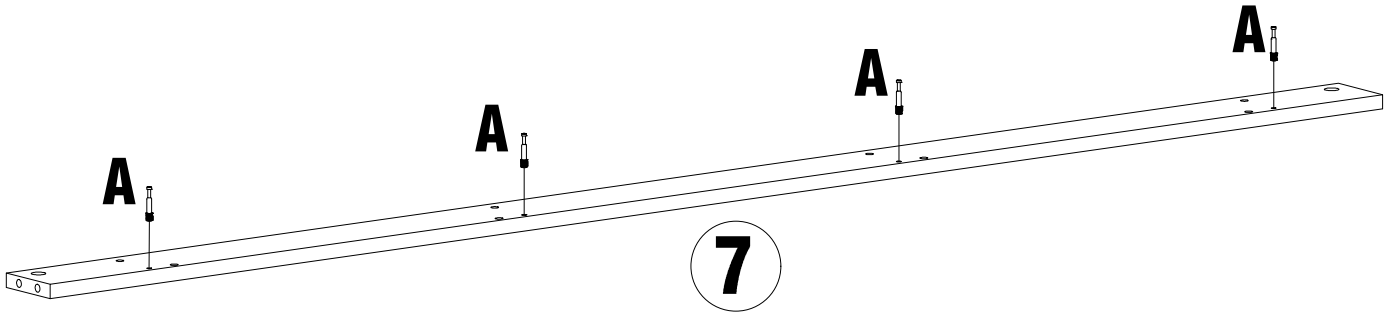
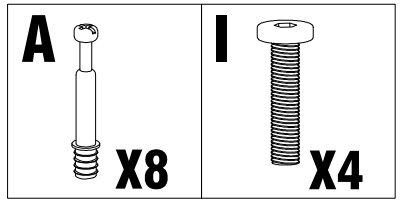

STEP 4

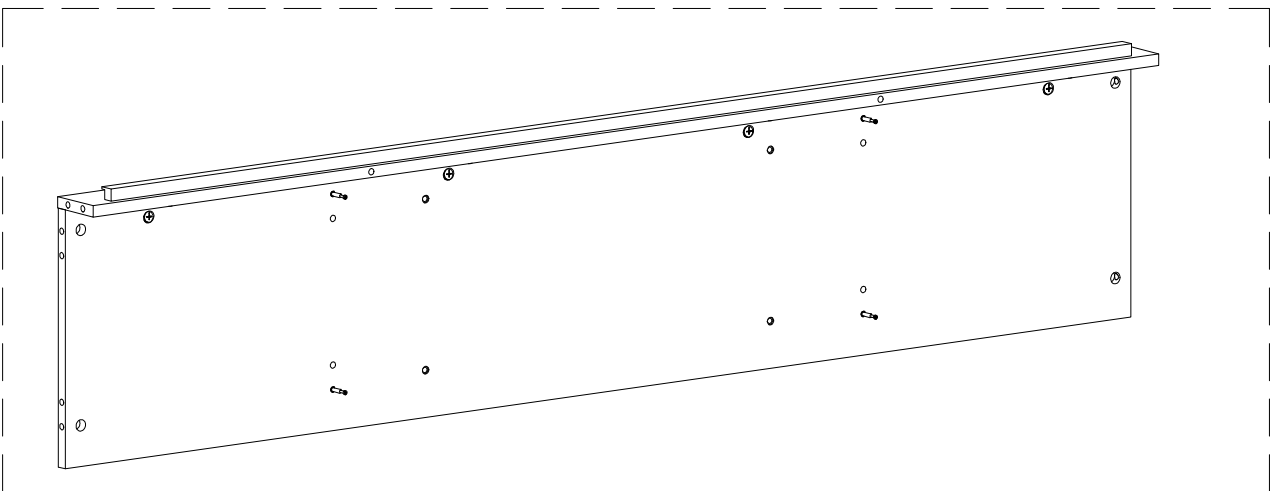
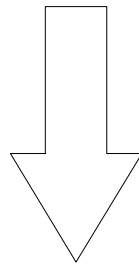
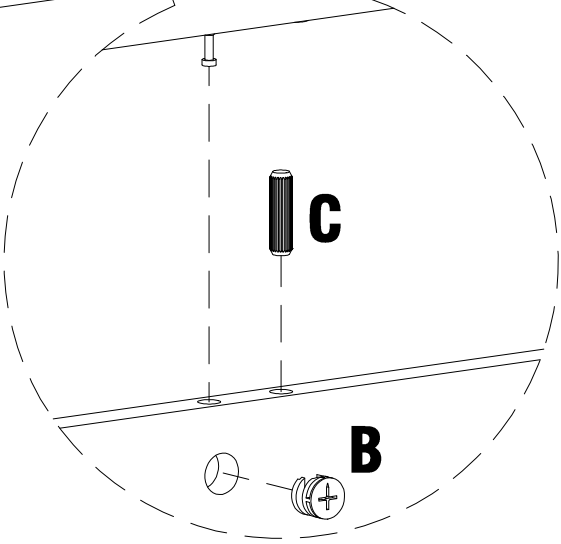
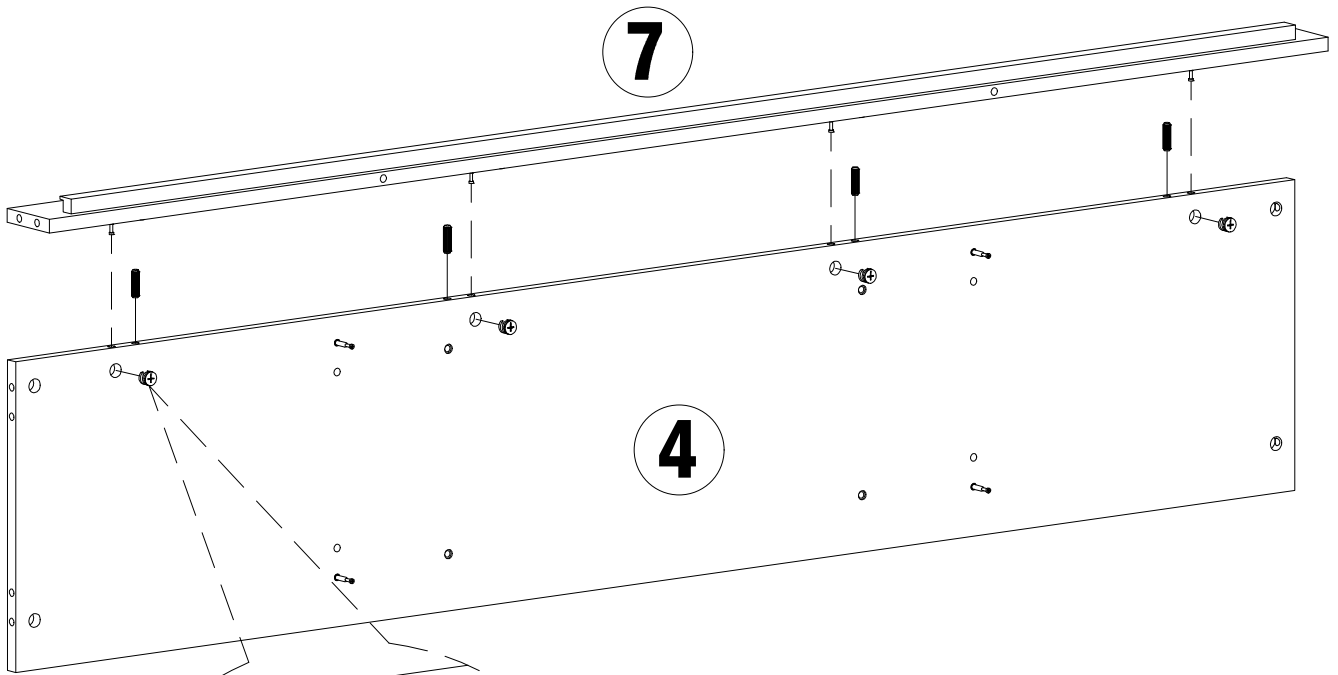
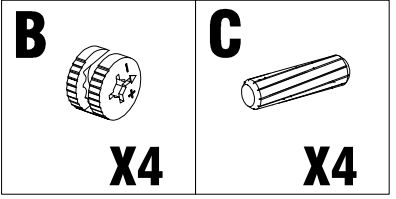

STEP 5



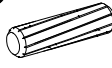

STEP 6

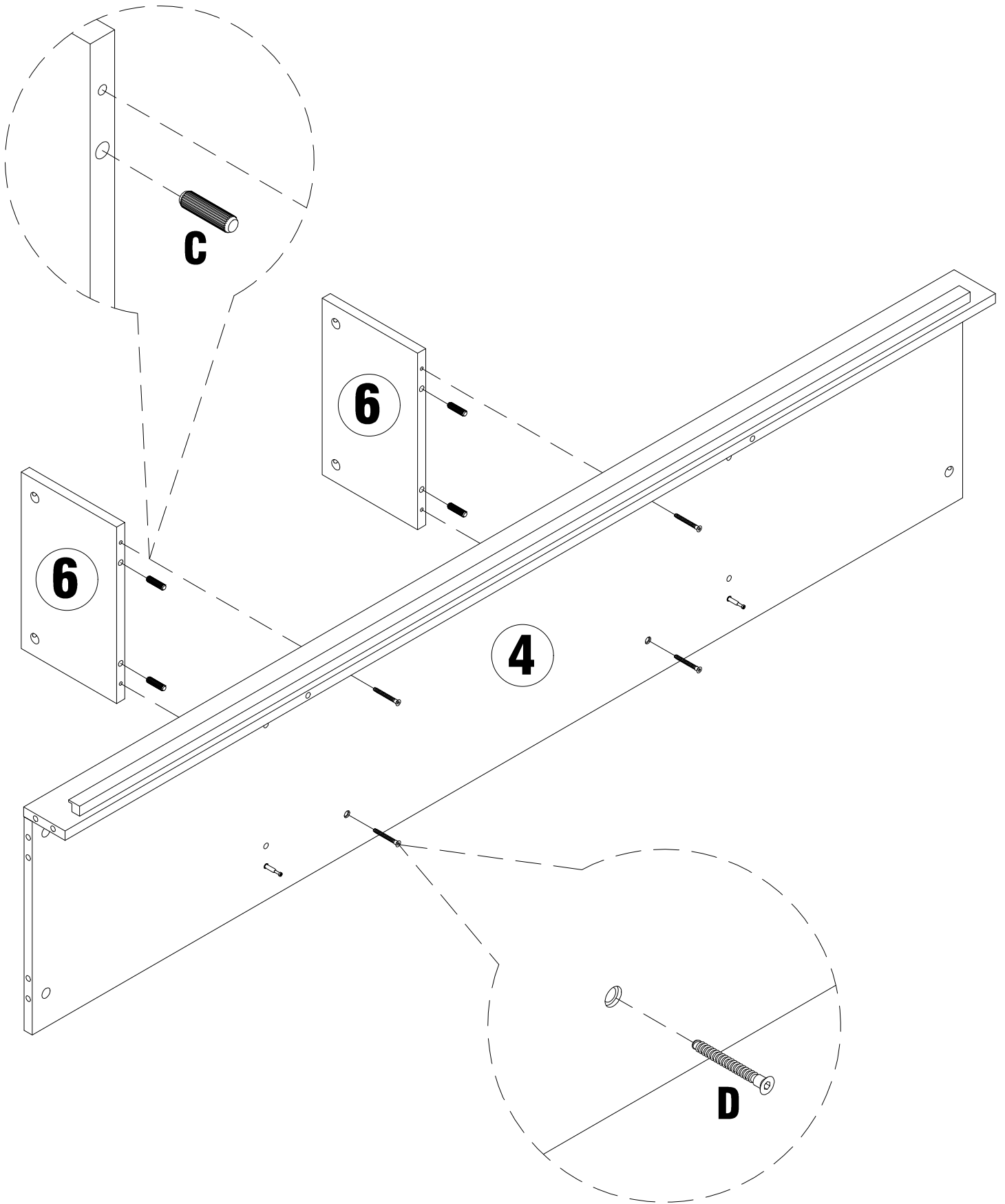
C  X4	D  X4
---	---



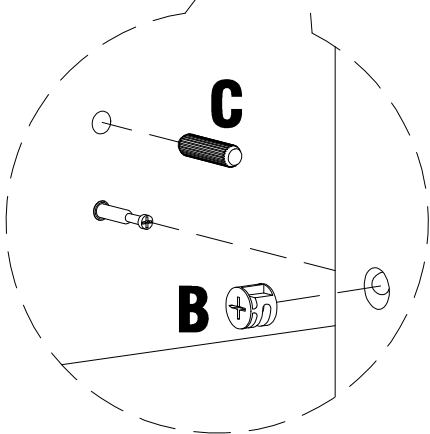
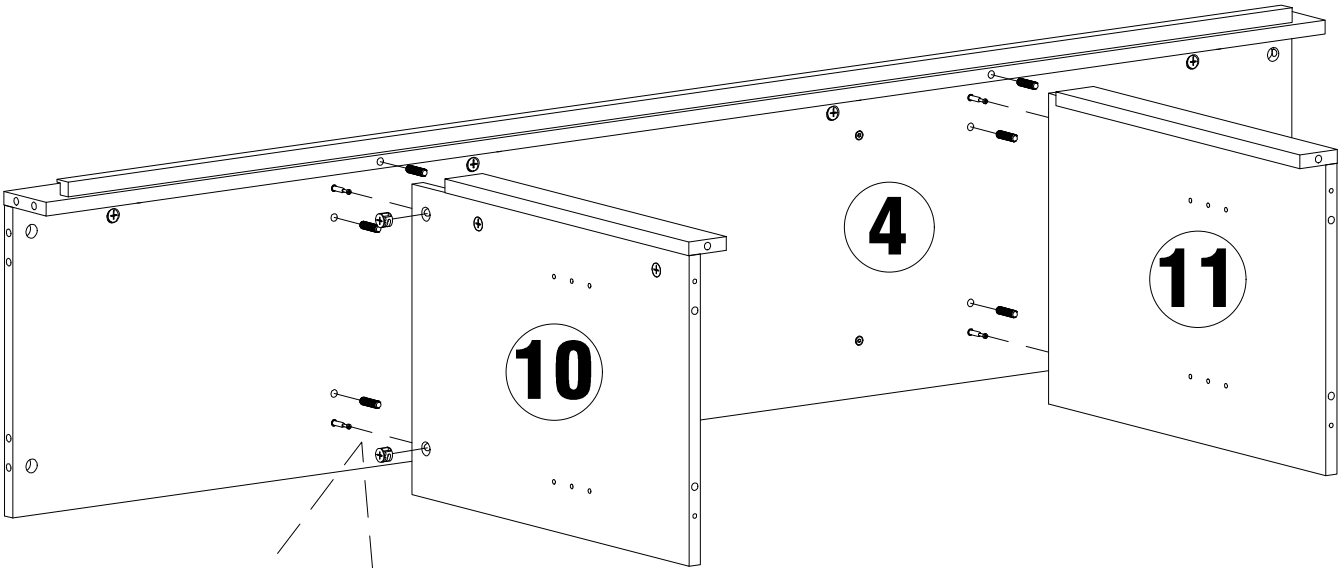

STEP 7

B  X4	C  X6
---	---



STEP 8

B  X6	C  X6
---	---

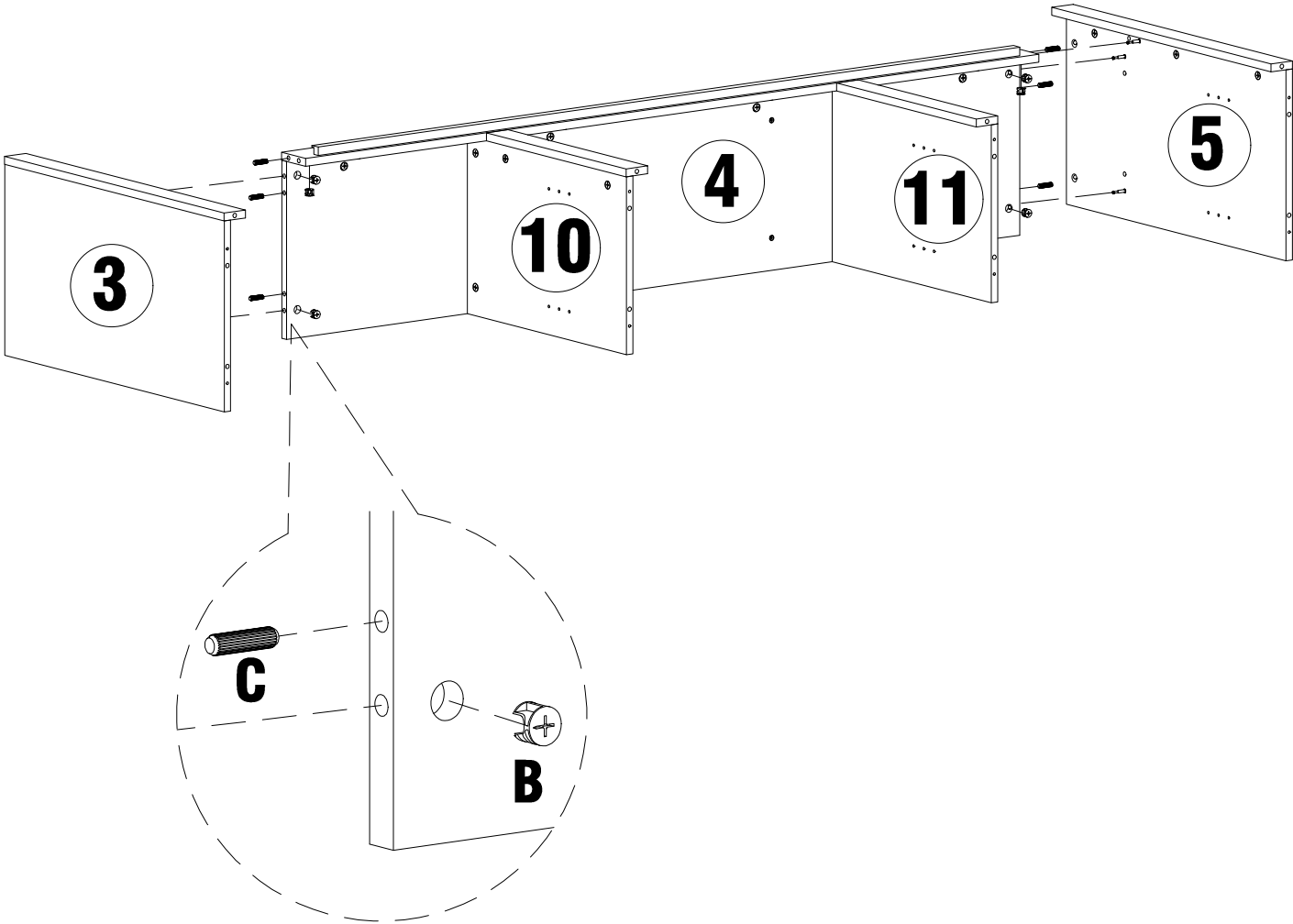

STEP 9

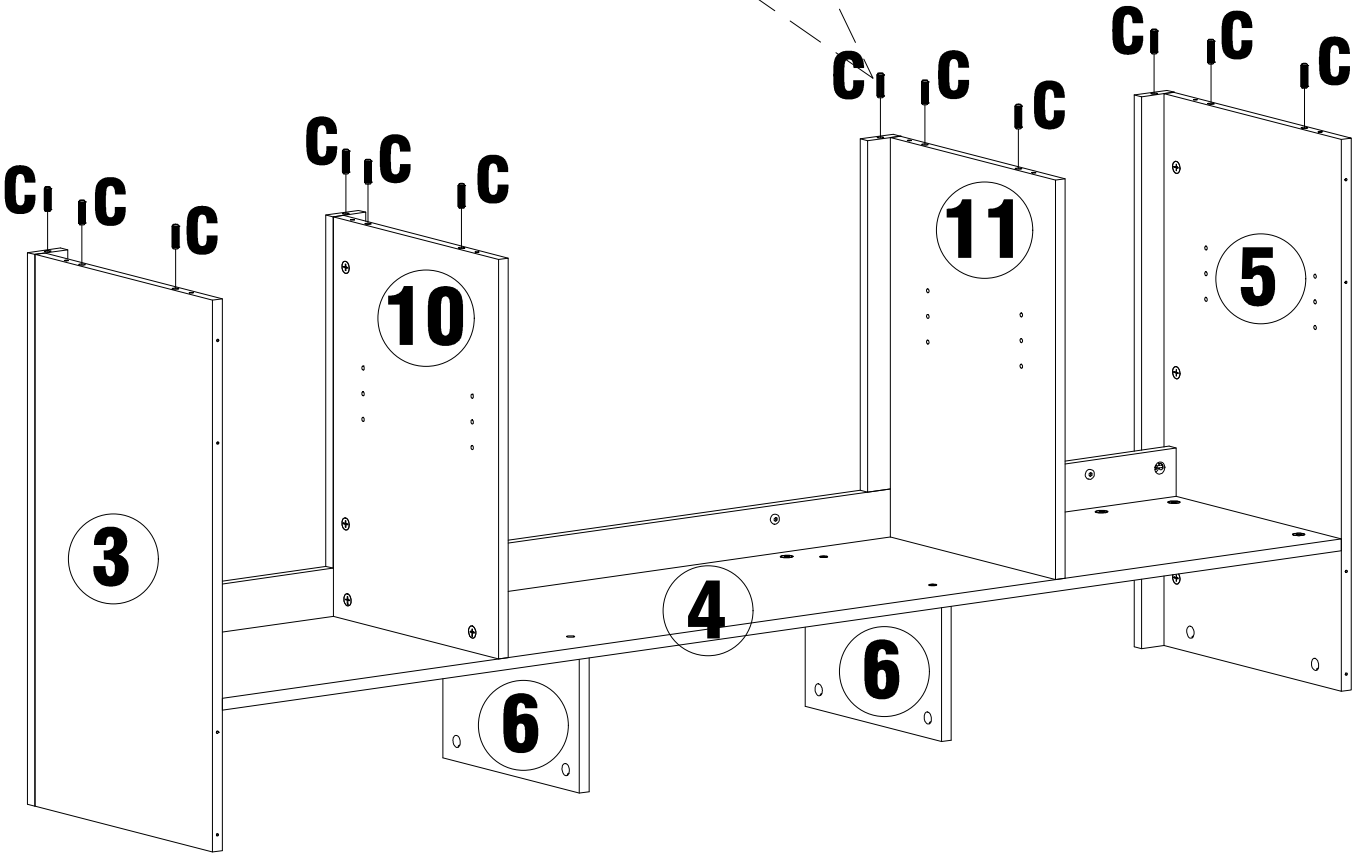
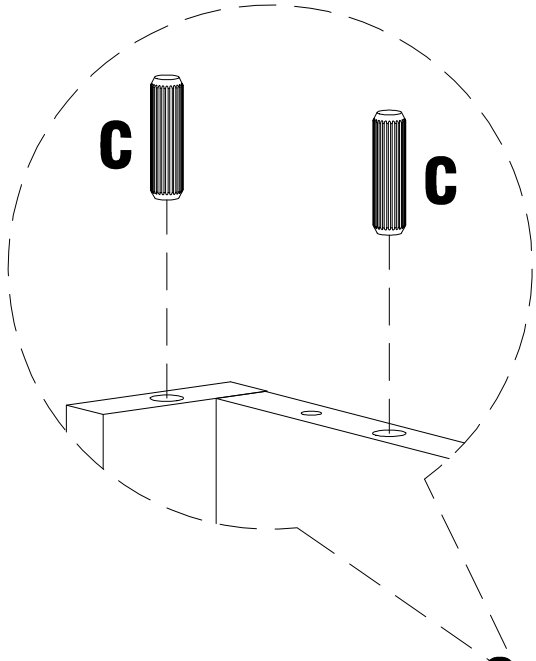
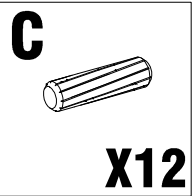

STEP 10

D  **X8**

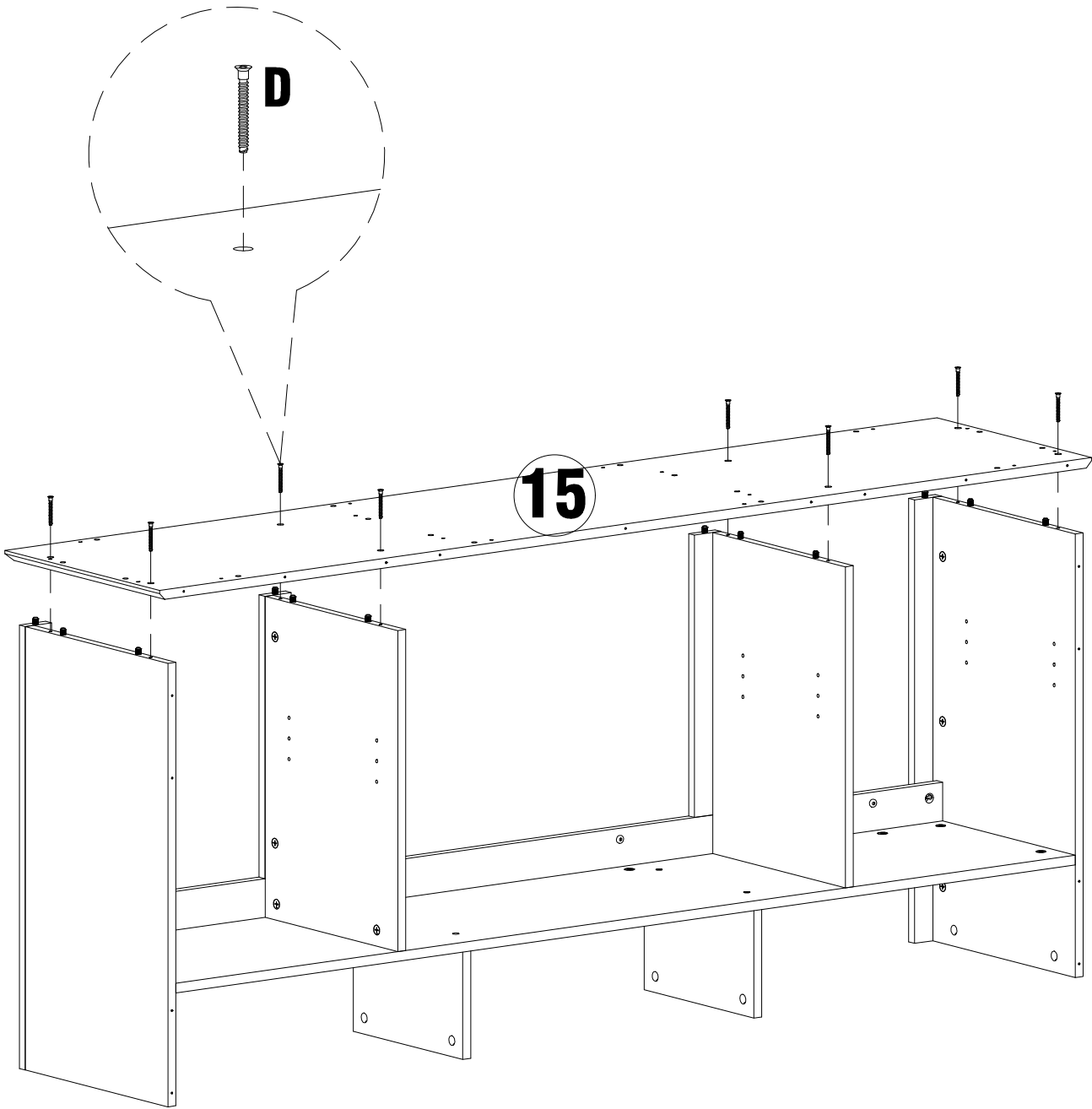

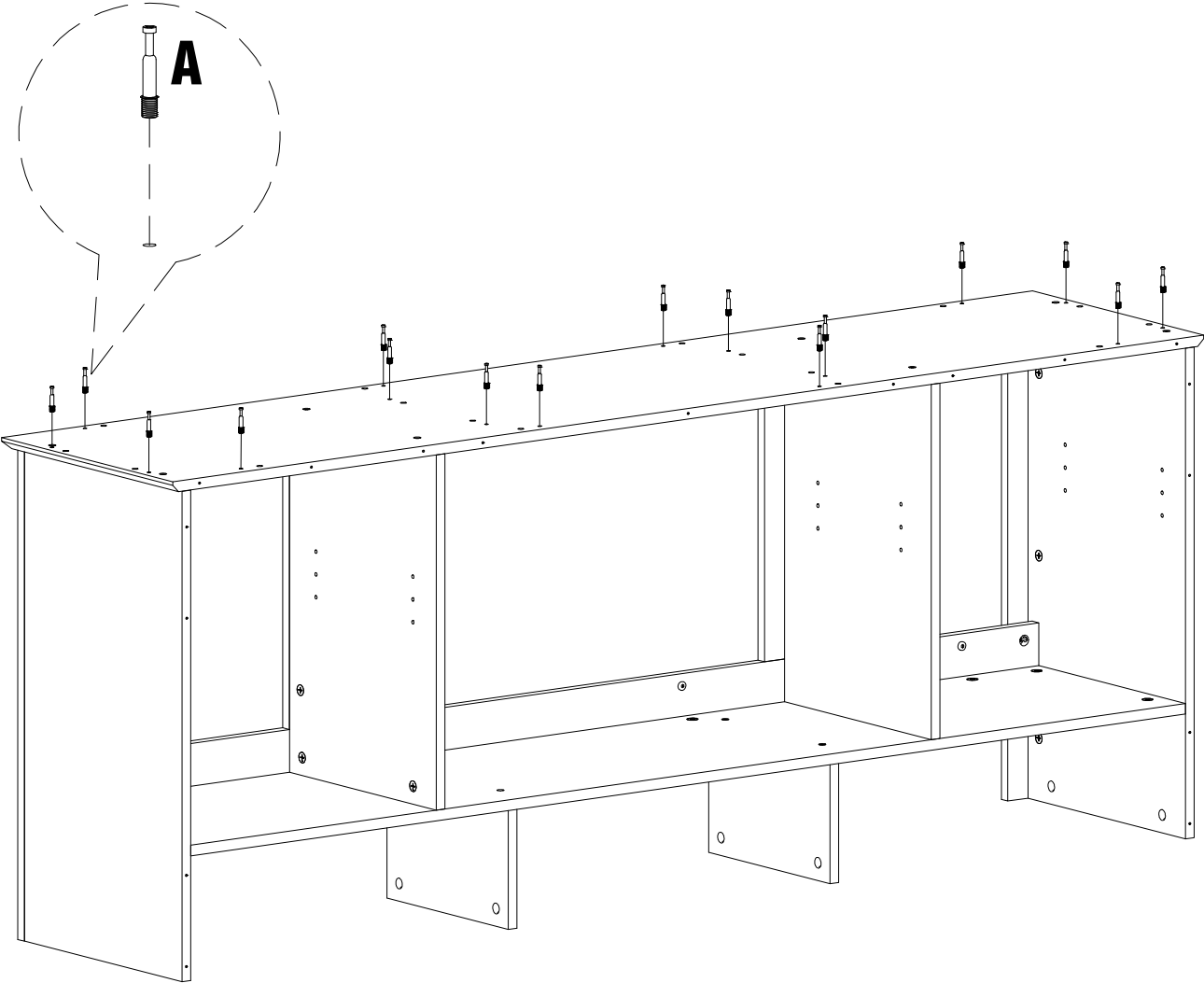
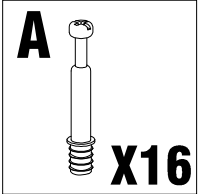

STEP 11

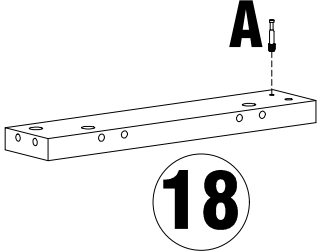
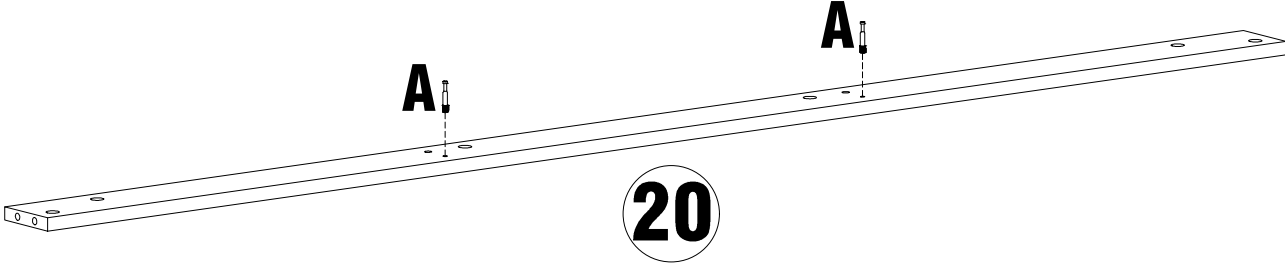
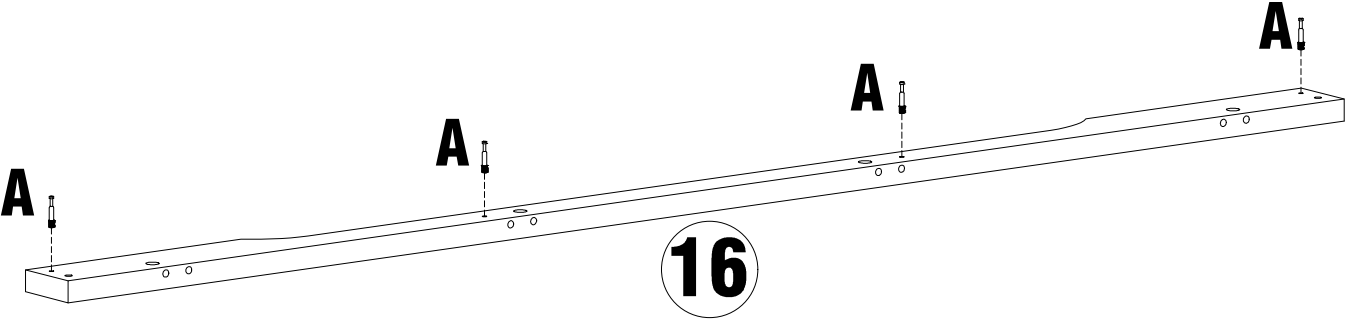
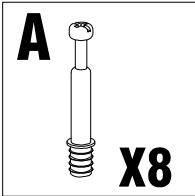

STEP 12



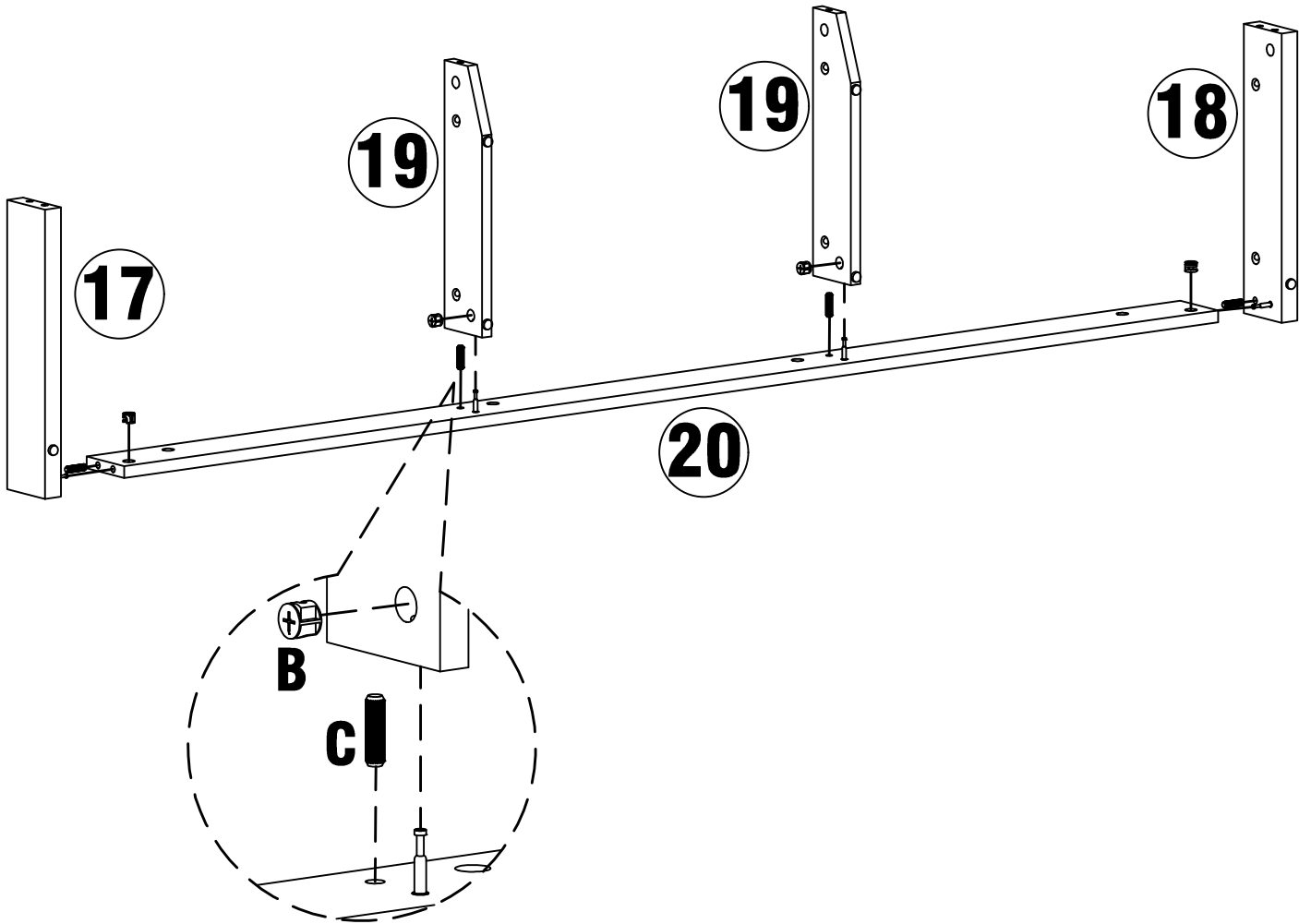

STEP 13

B  X4	C  X4
---	---



STEP 14

B  X4	C  X2
---	---

16

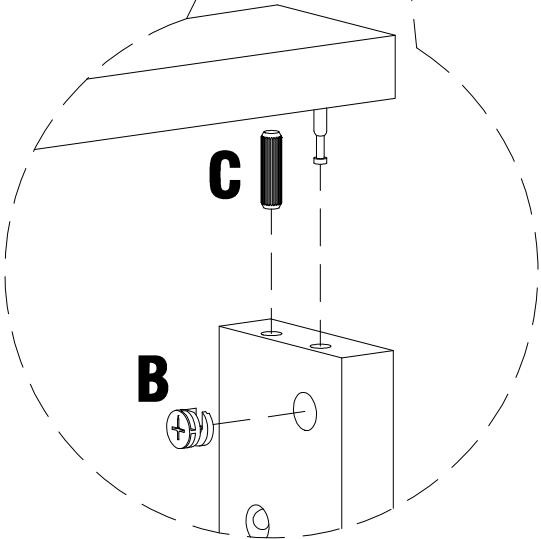
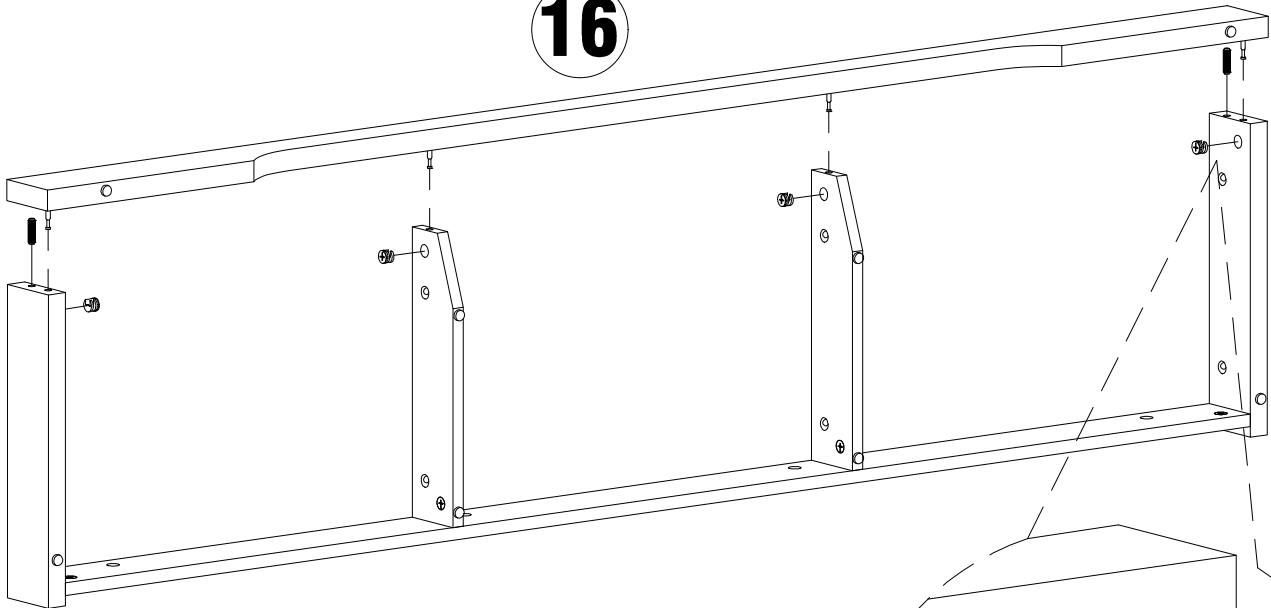

STEP 15

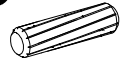
C

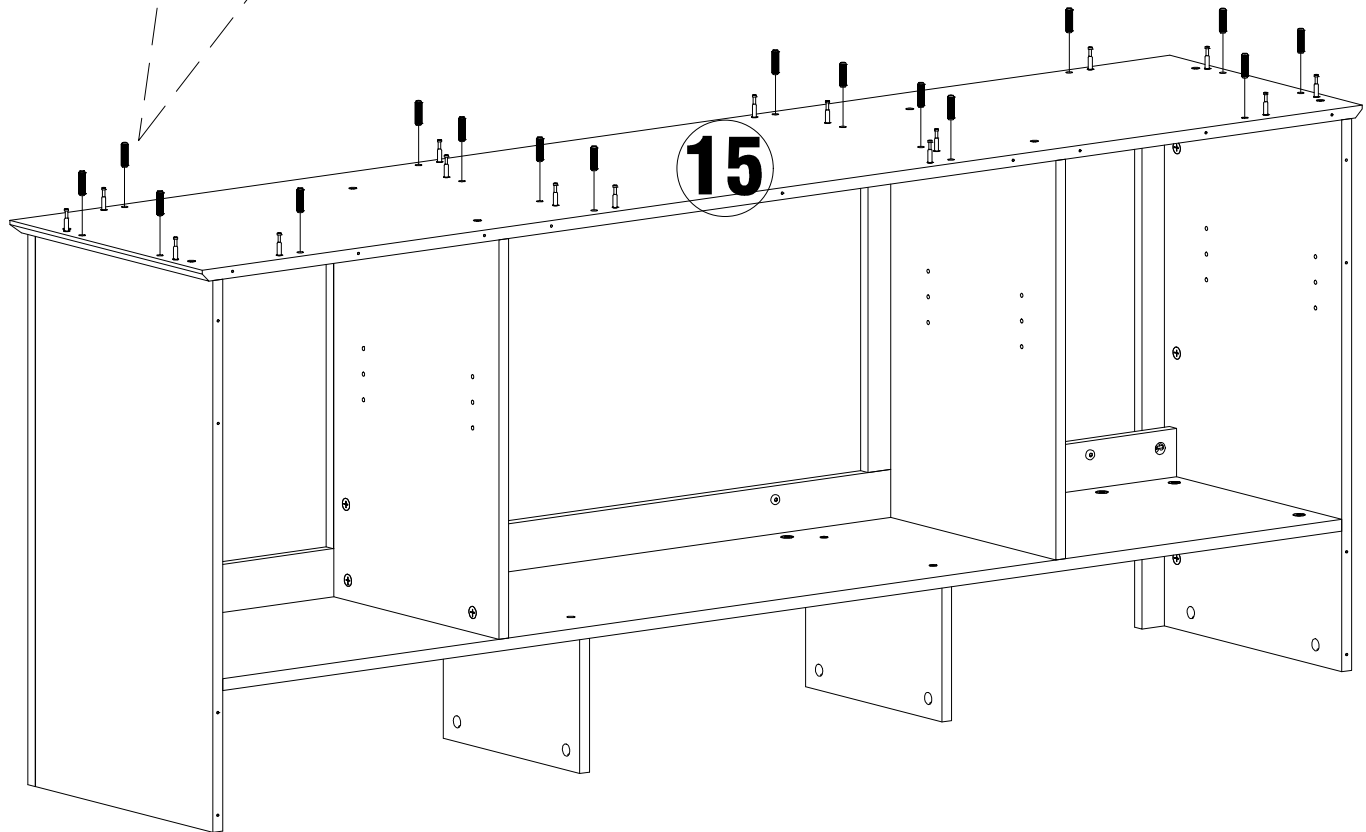
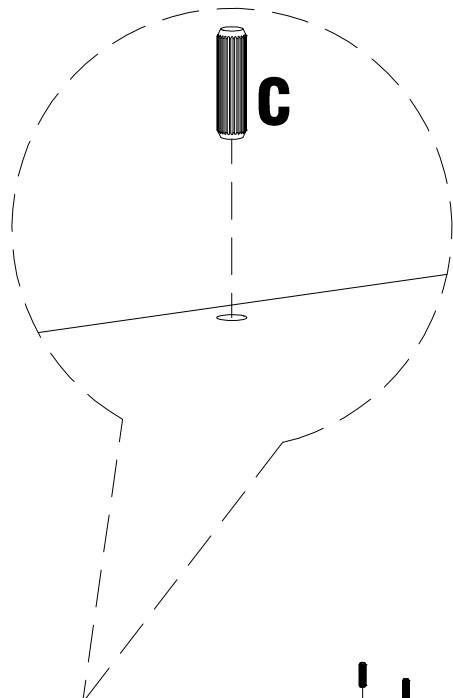
X16

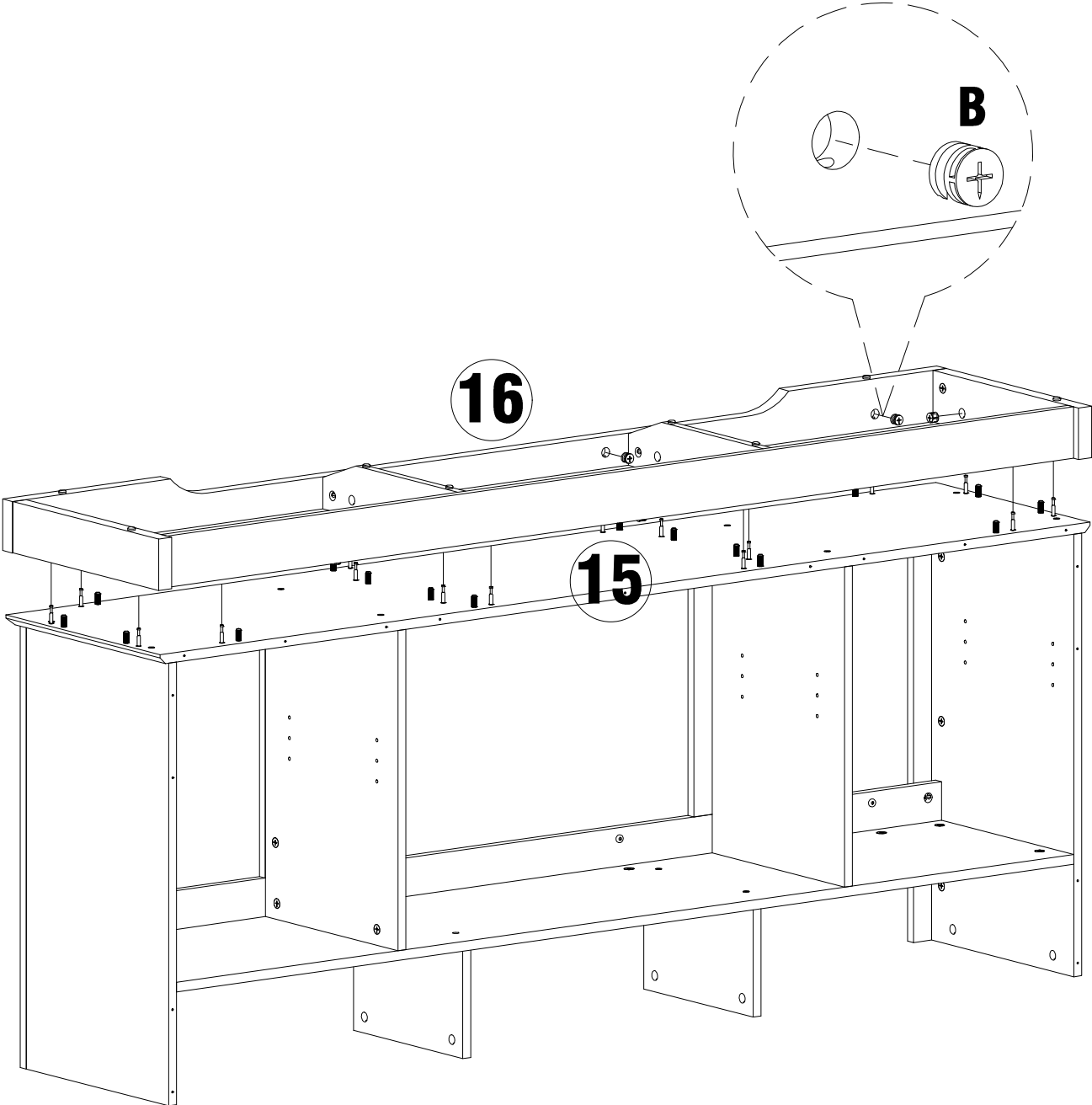

STEP 16

B

X16

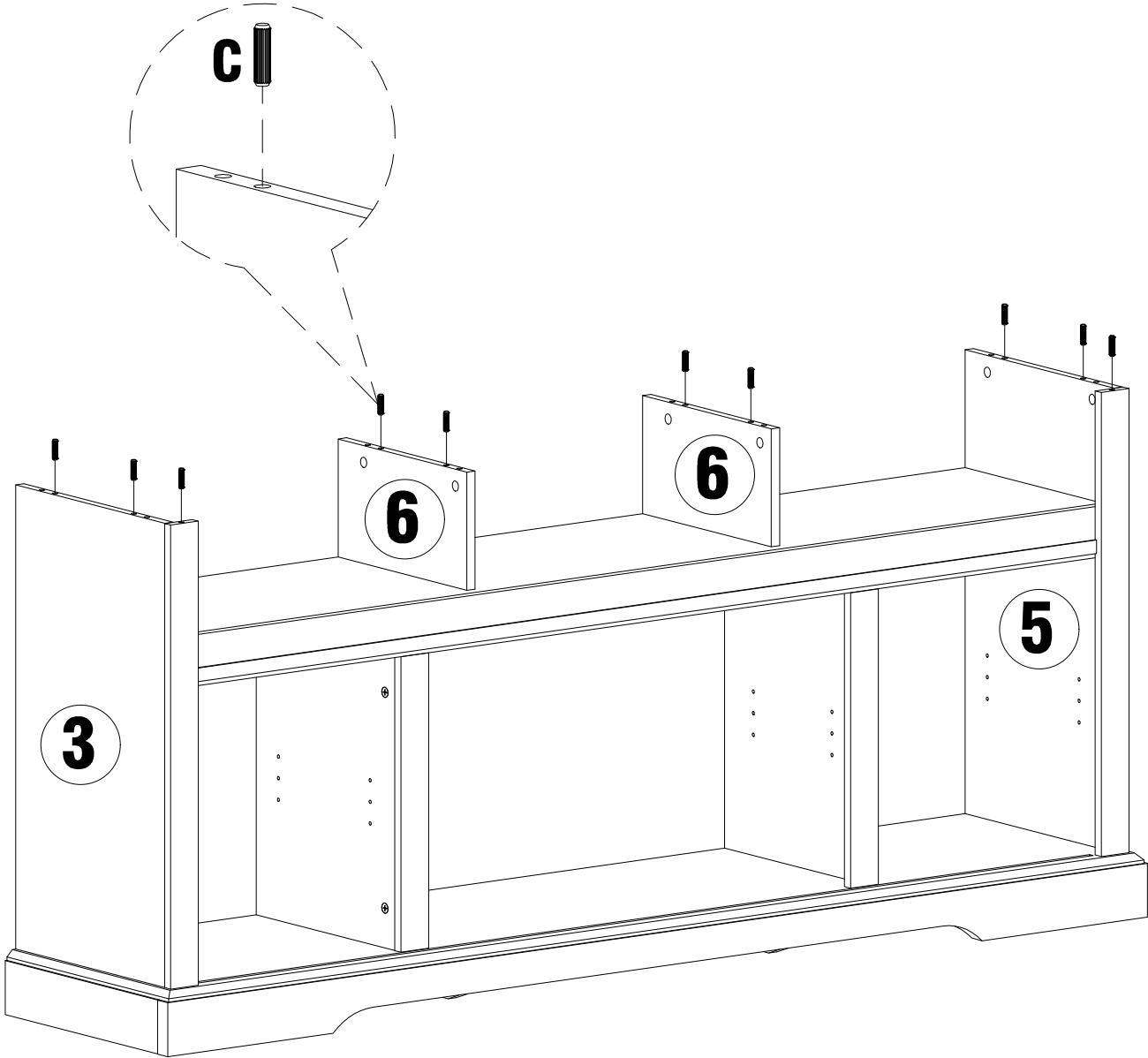

STEP 17

C

X10

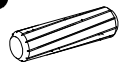
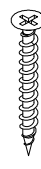

STEP 18

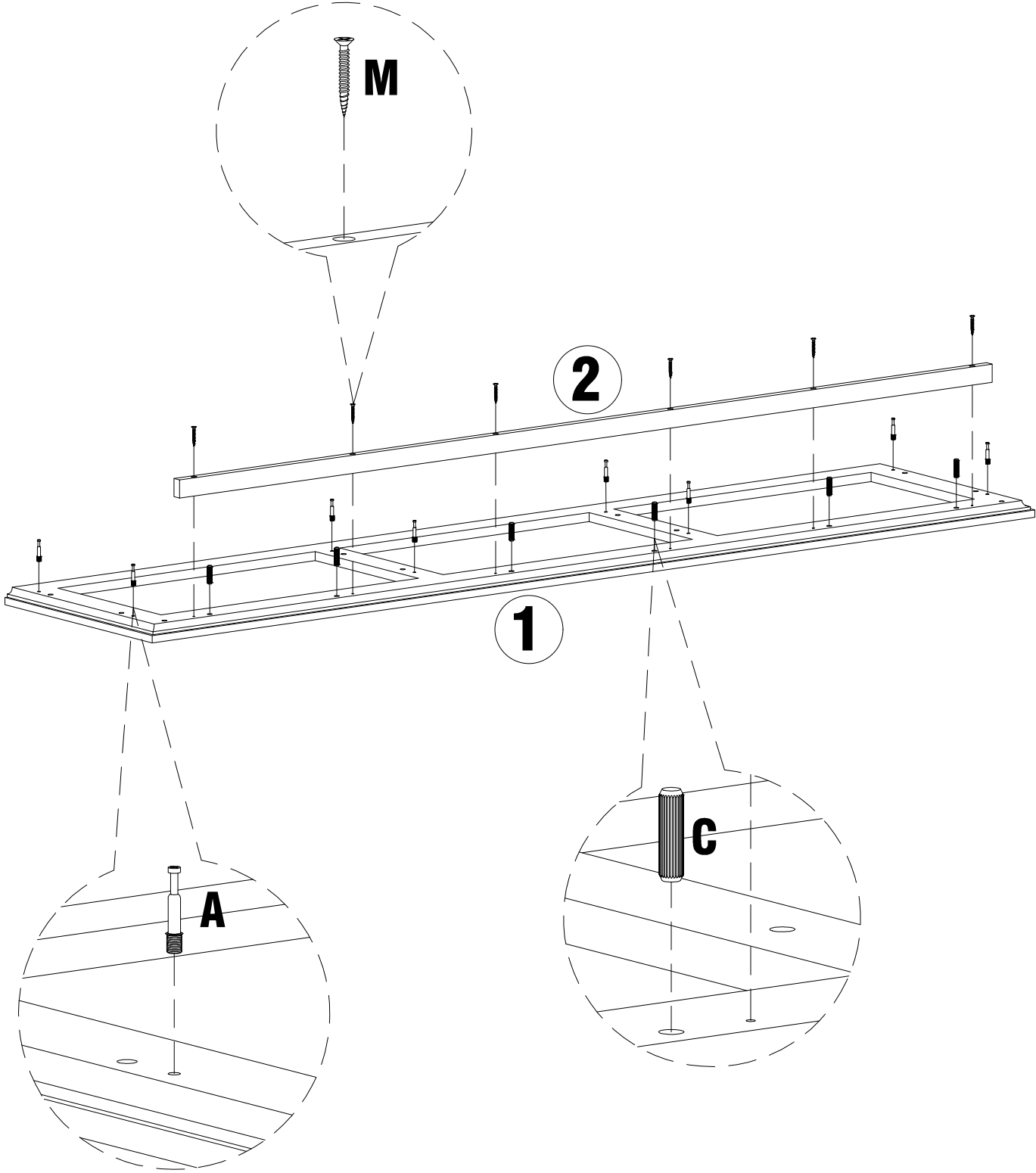
A  X8	C  X6	M  X6
---	---	---



STEP 19

B 
X8

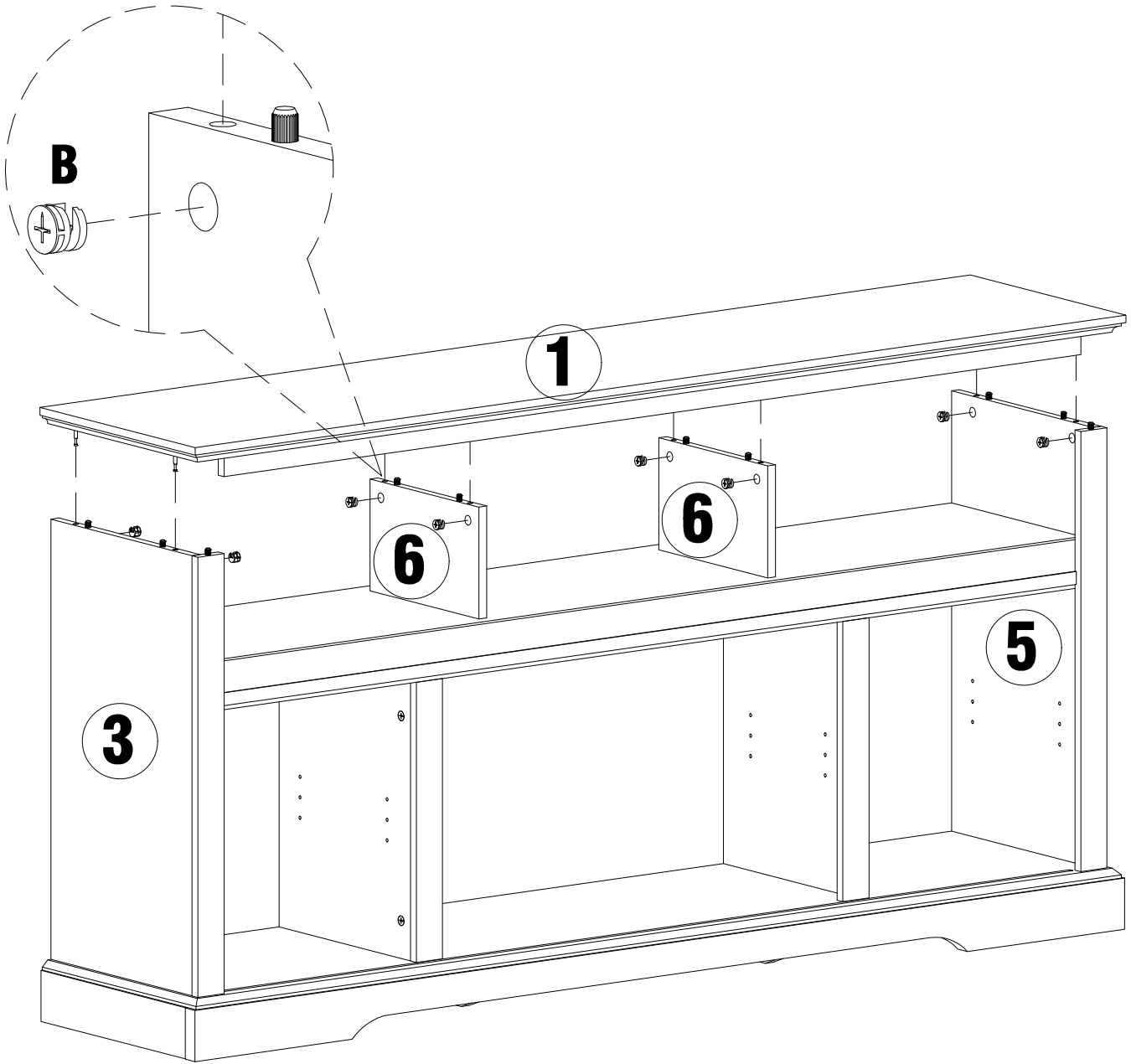

STEP 20

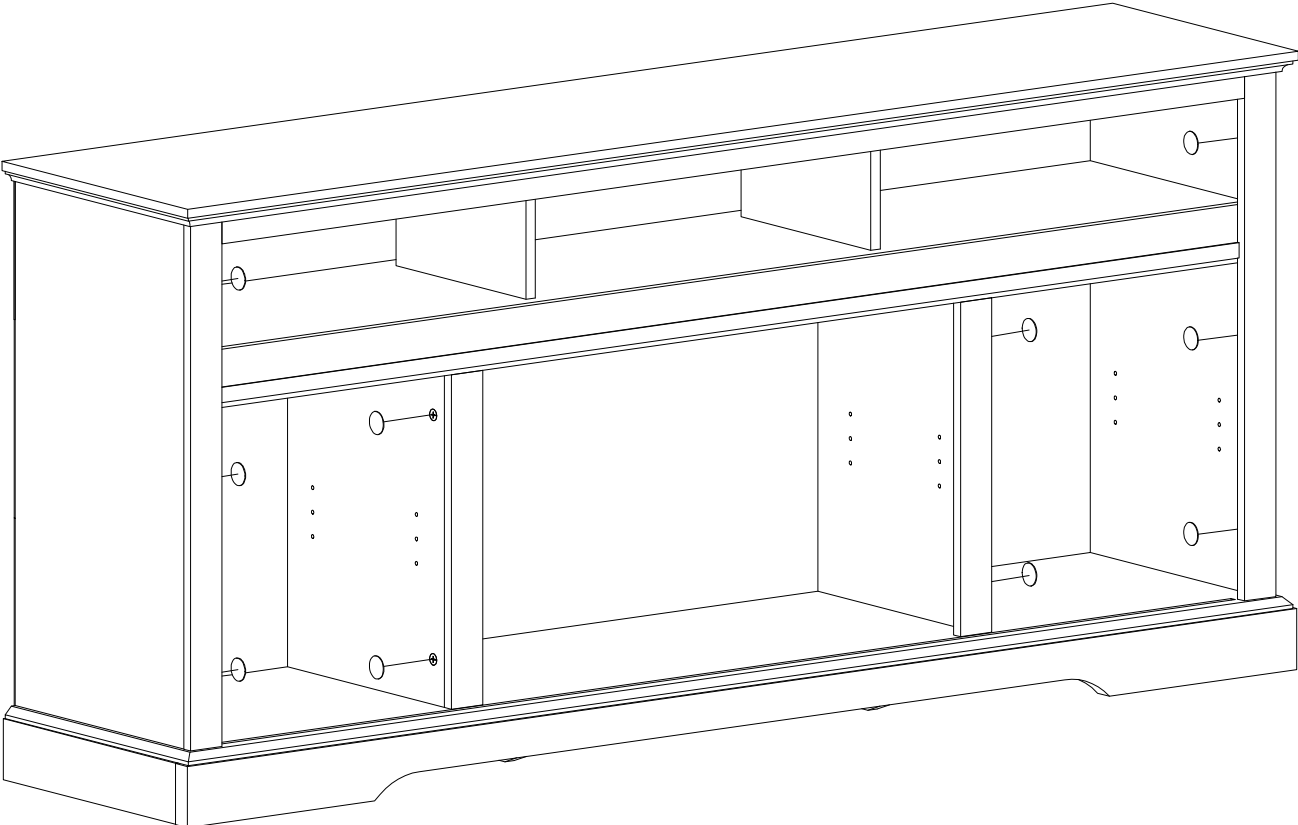
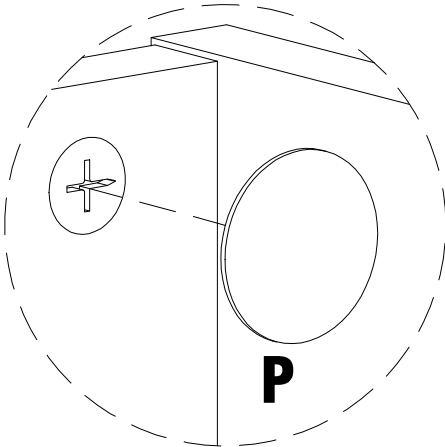
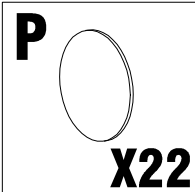

If you intended to use this product as a TV stand, continue the assembly instruction on page 25

If you intended to use this product as a fireplace mantel, continue the assembly instruction on page 30

TV STAND ASSEMBLY

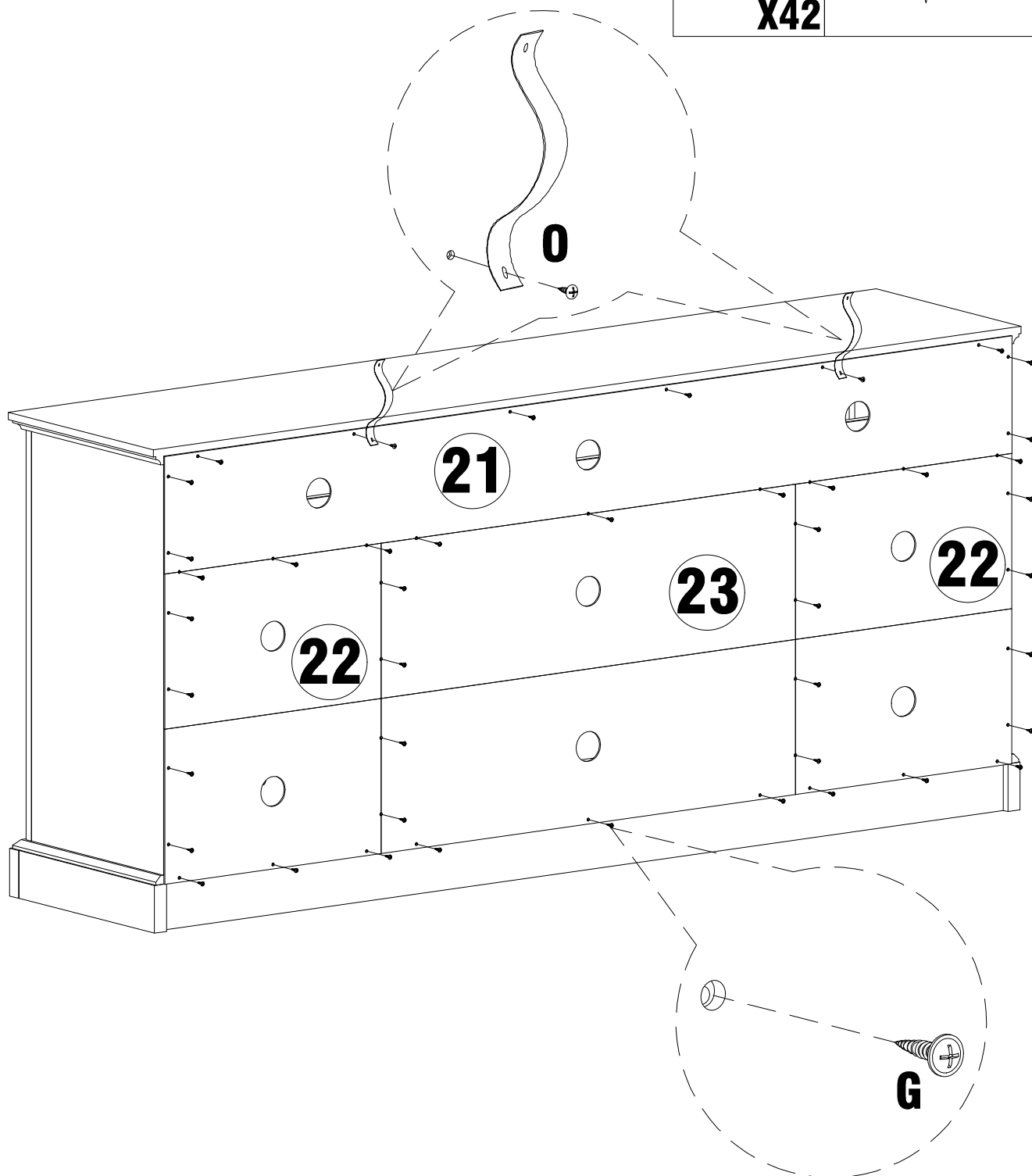
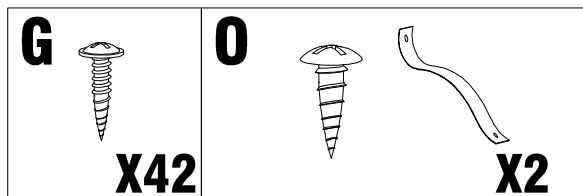

STEP 21

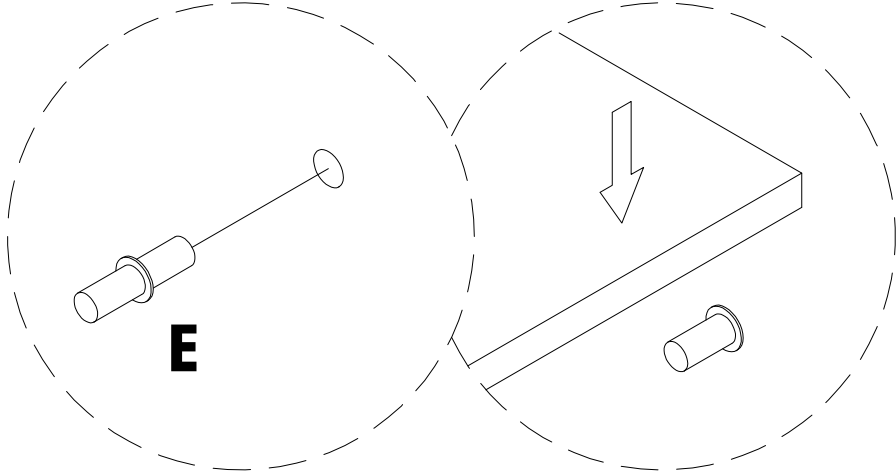
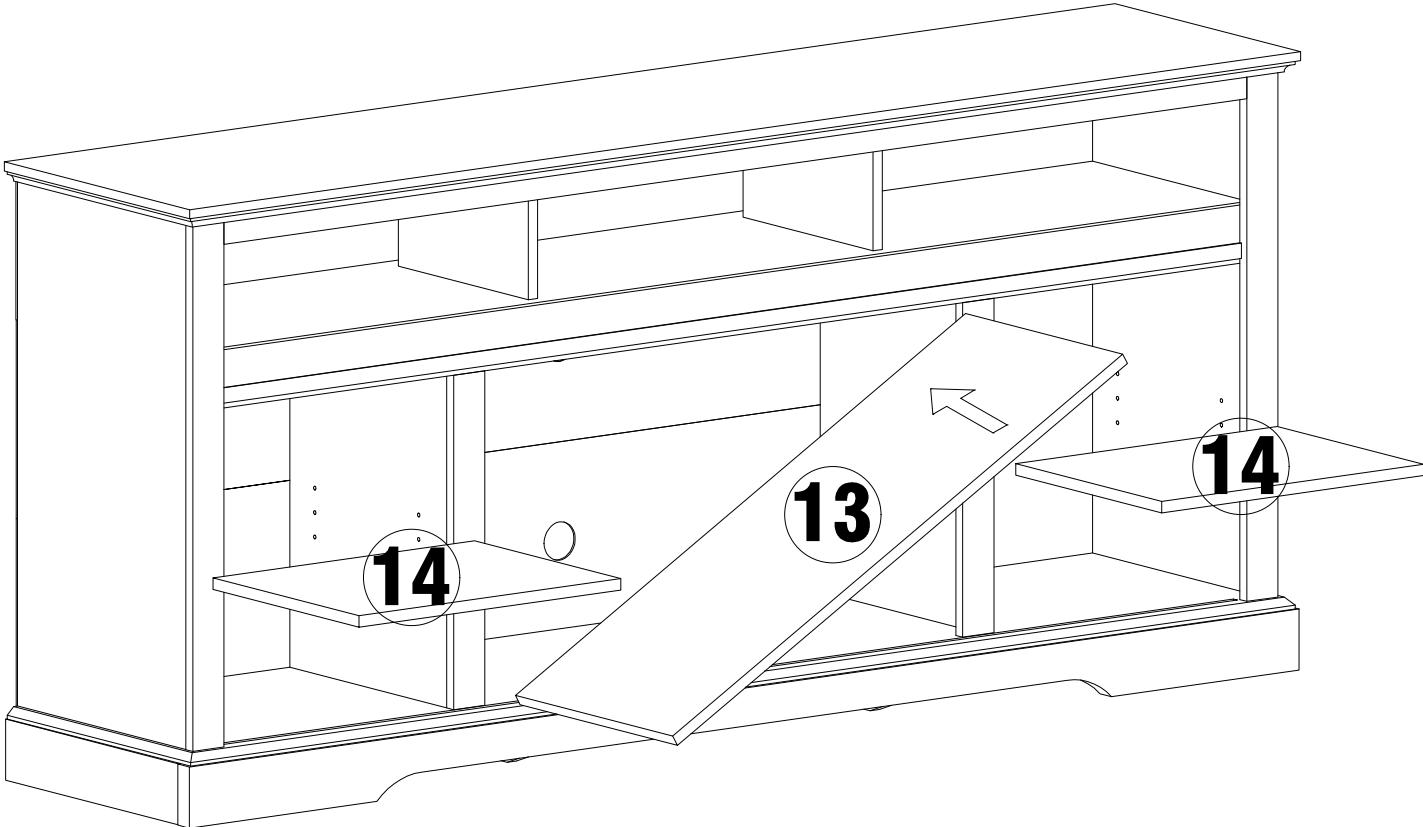
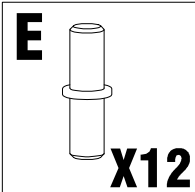

STEP 22

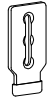
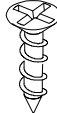
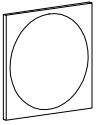

STEP 23

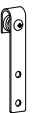
K  X4	L  X8	N  X8	H  X8	J  X4
---	---	---	---	---

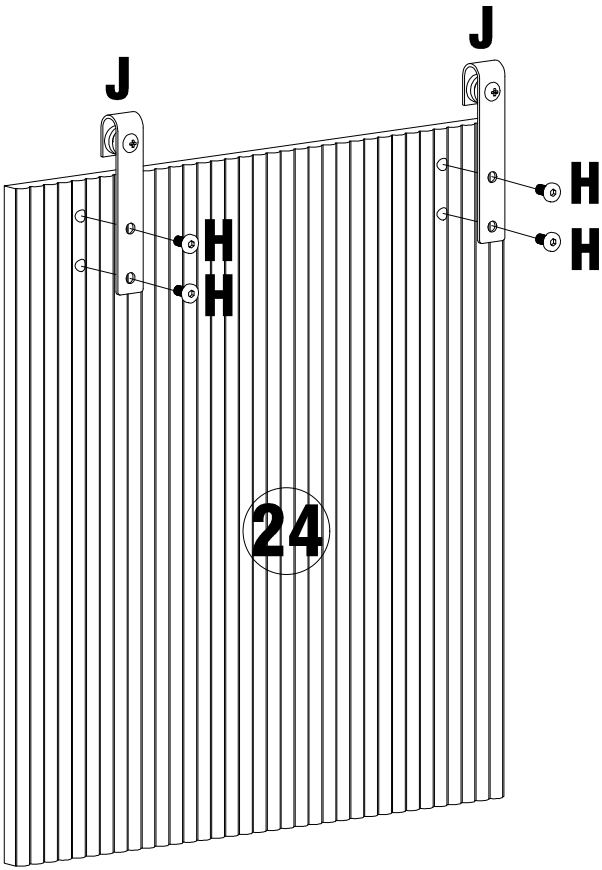

x2

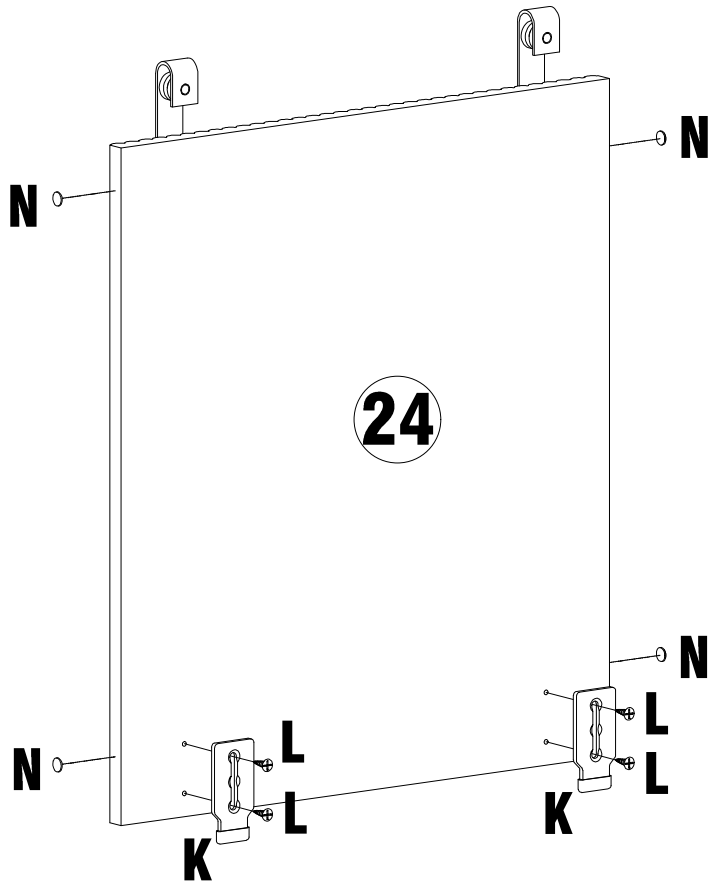

STEP 24

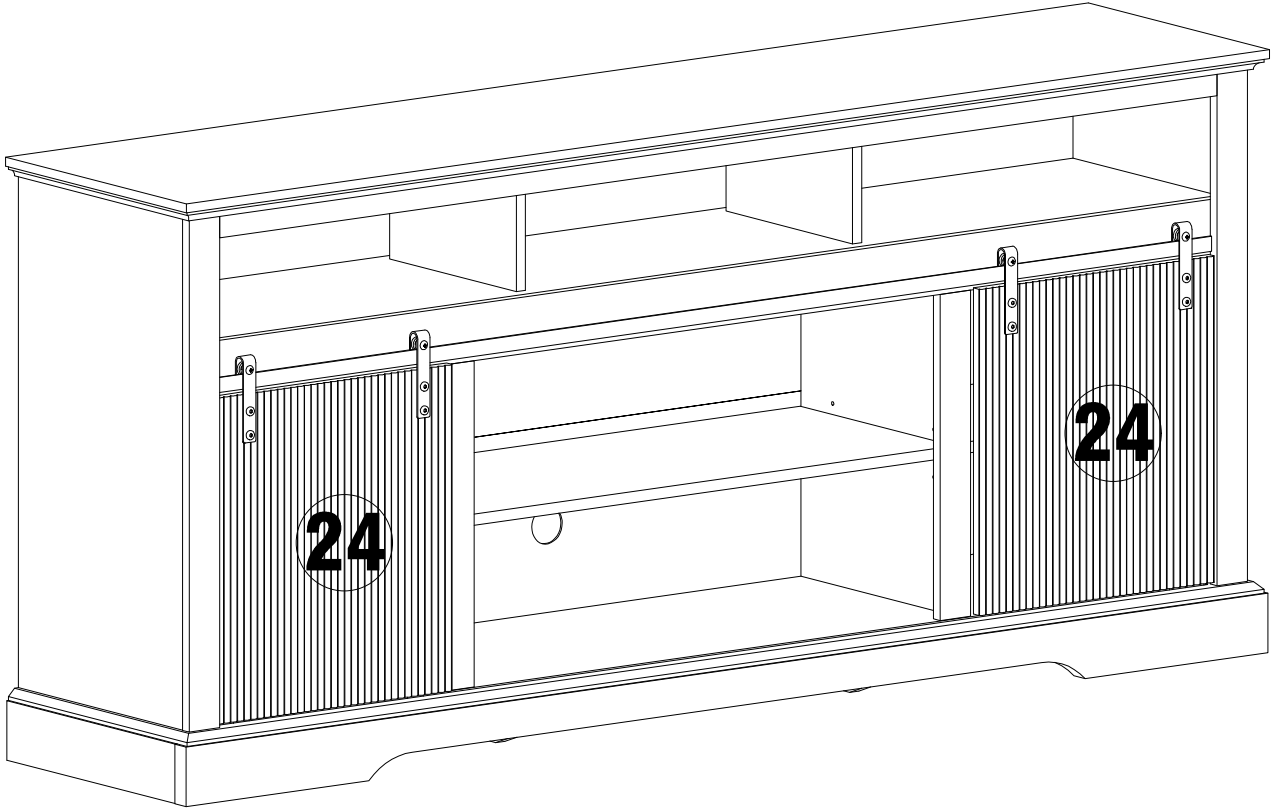
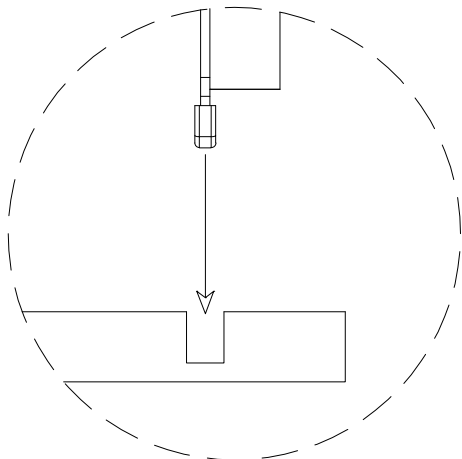
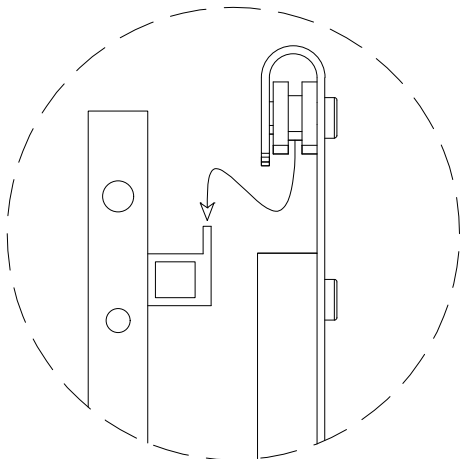

STEP 25

0

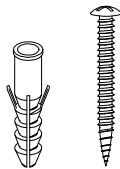

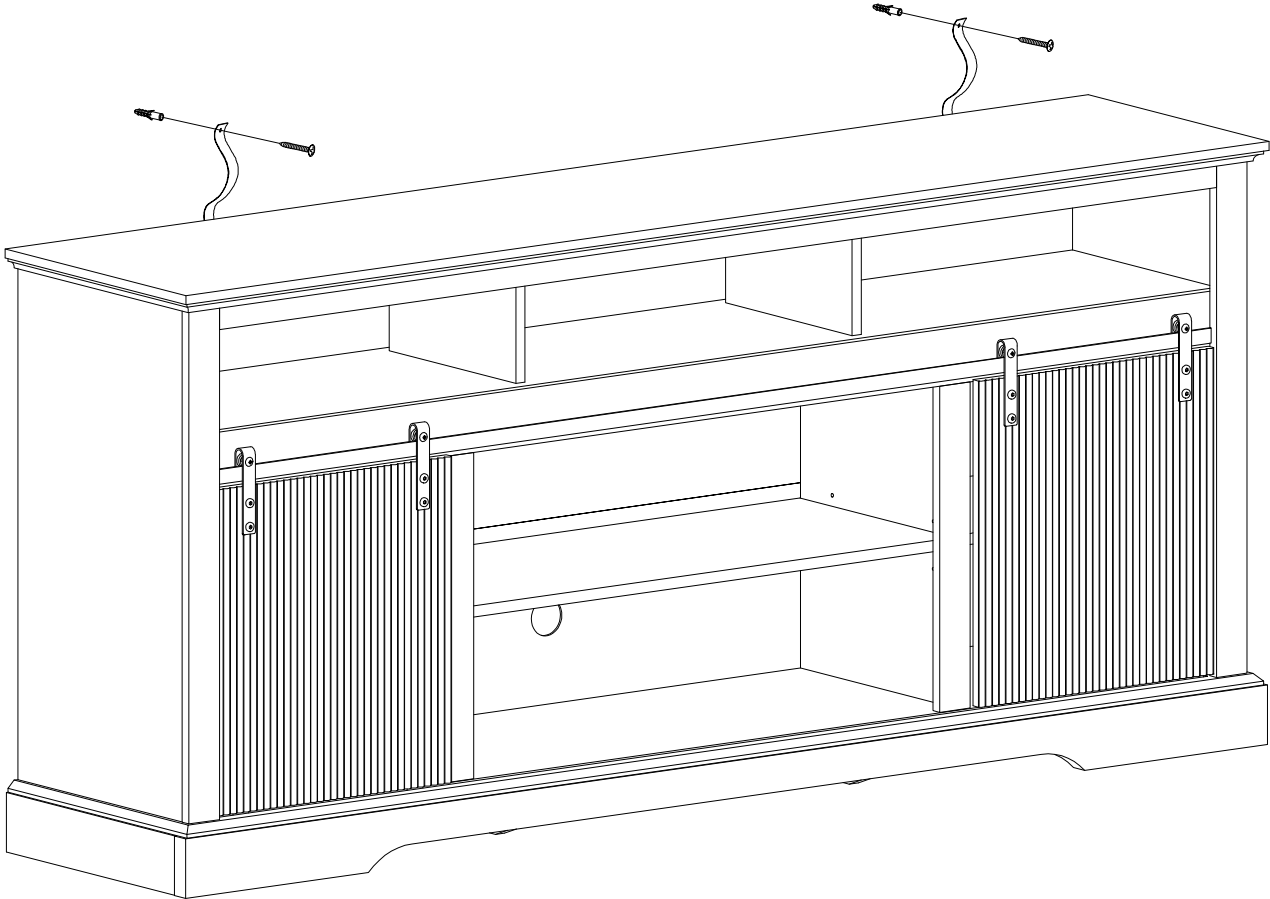
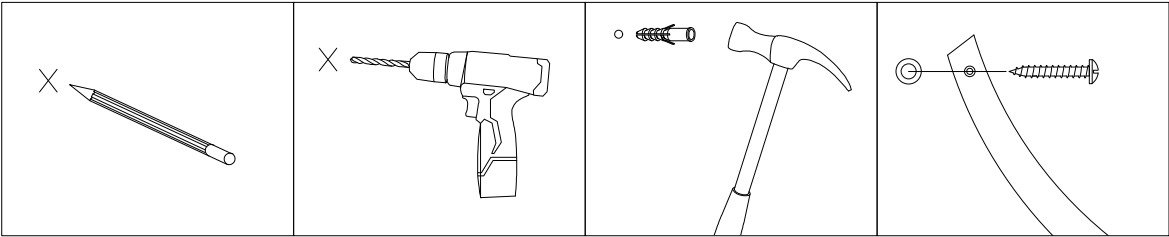

X2



FIREPLACE MANTEL ASSEMBLY

STEP 26

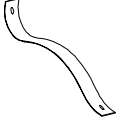

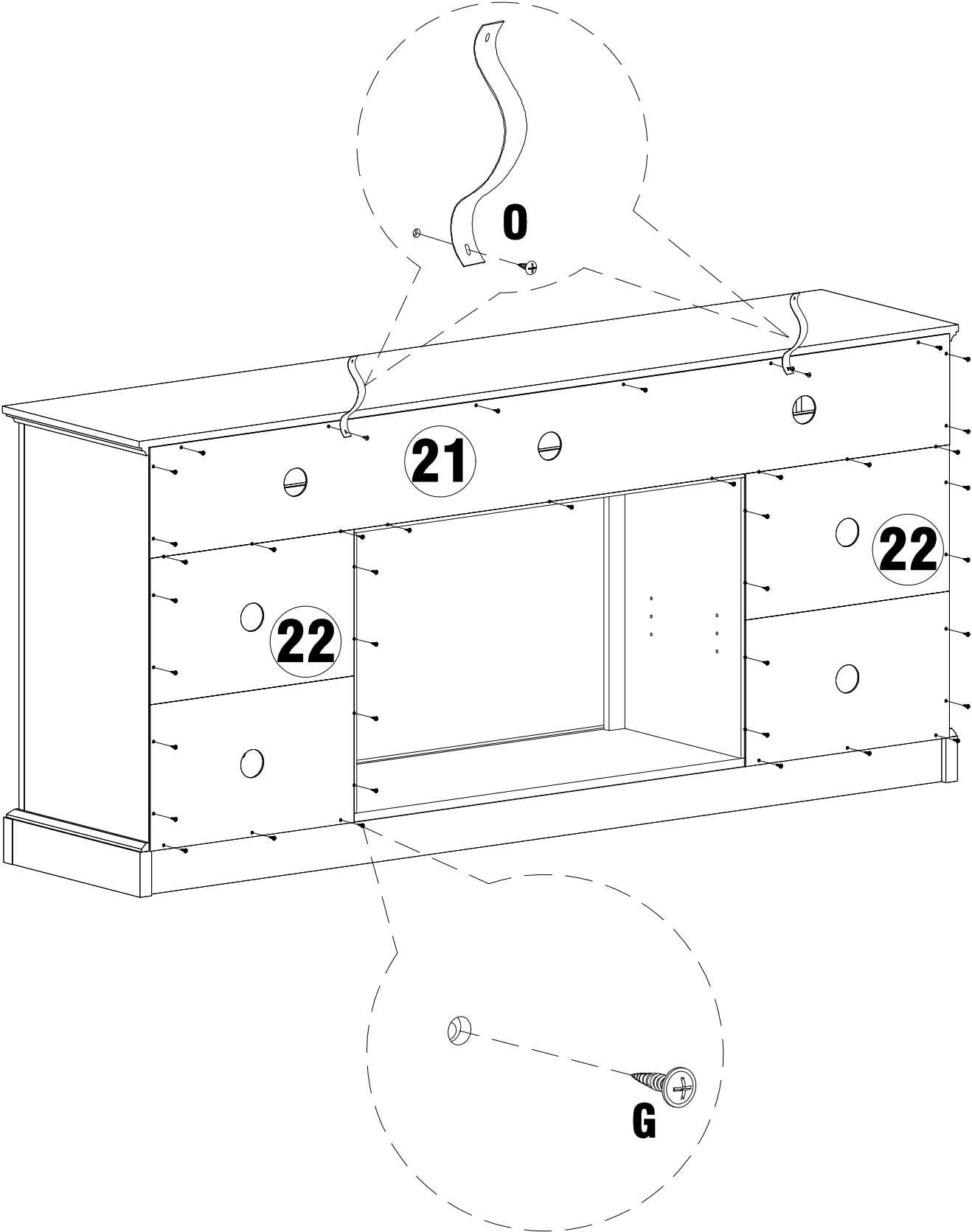
G		O		
	X39			X2

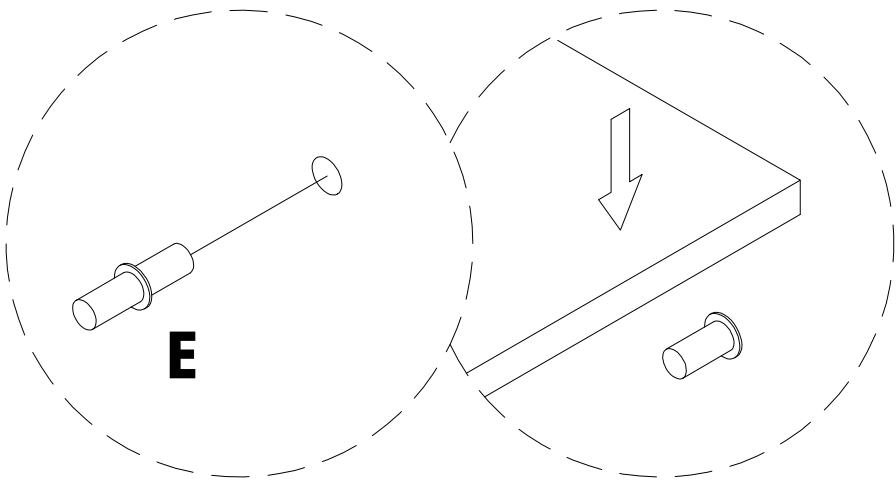
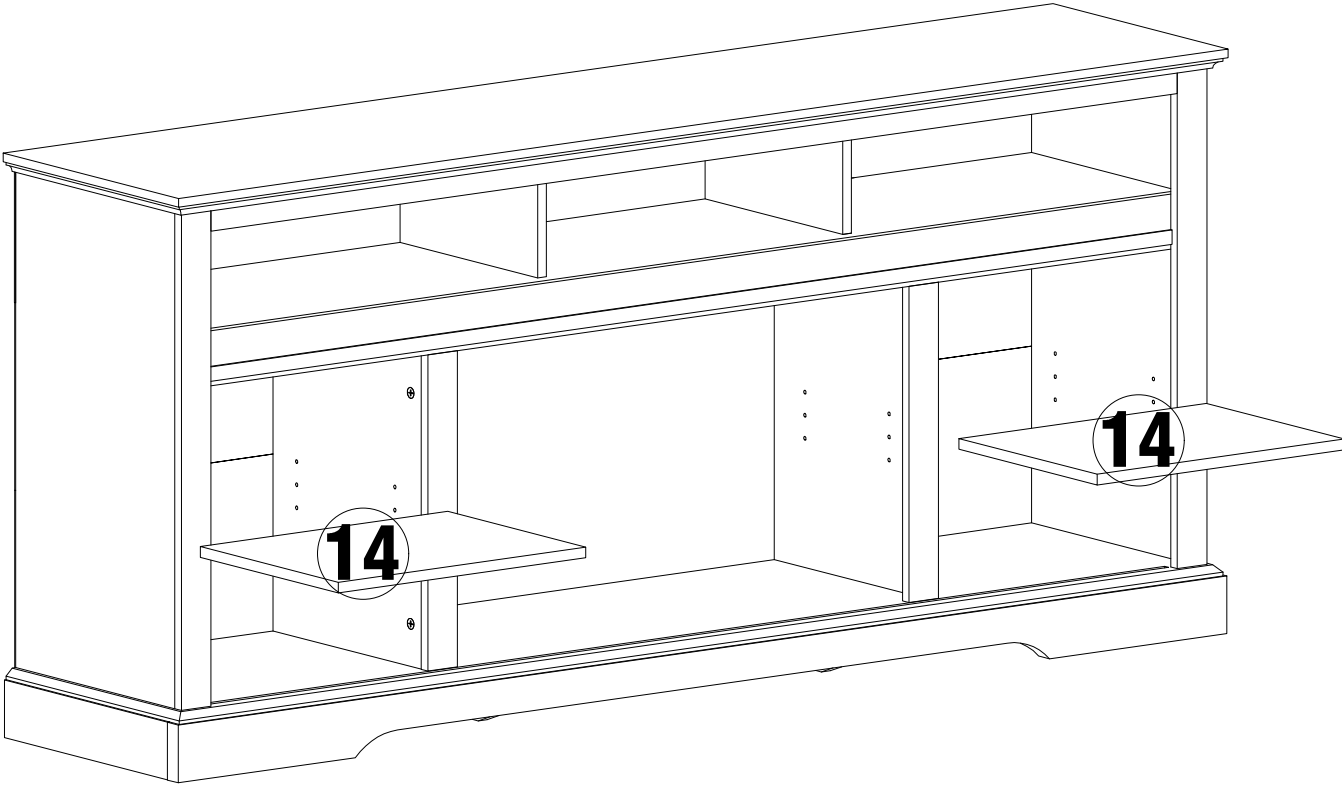
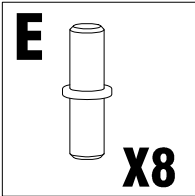

STEP 27

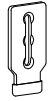
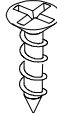
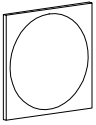

STEP 28

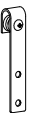
K  X4	L  X8	N  X8	H  X8	J  X4
---	---	---	---	---

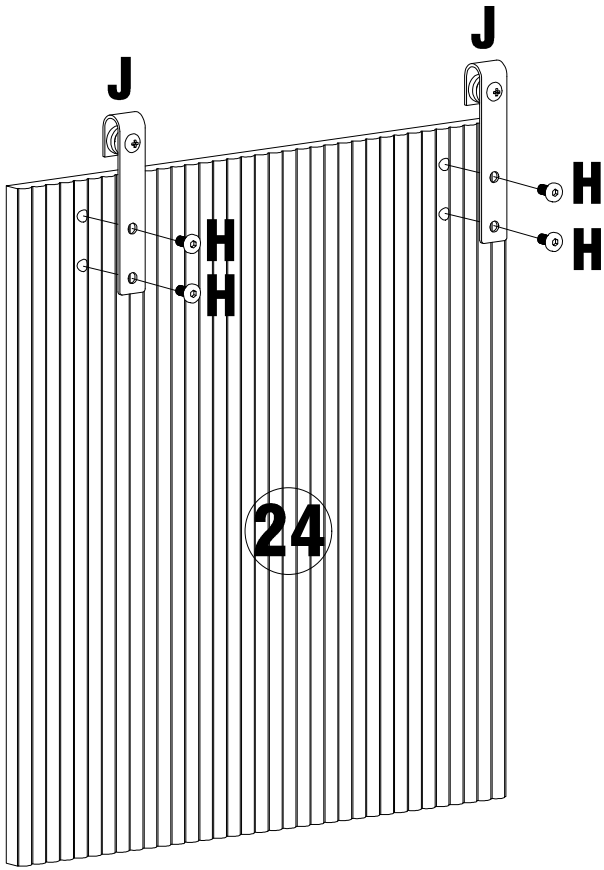

x2

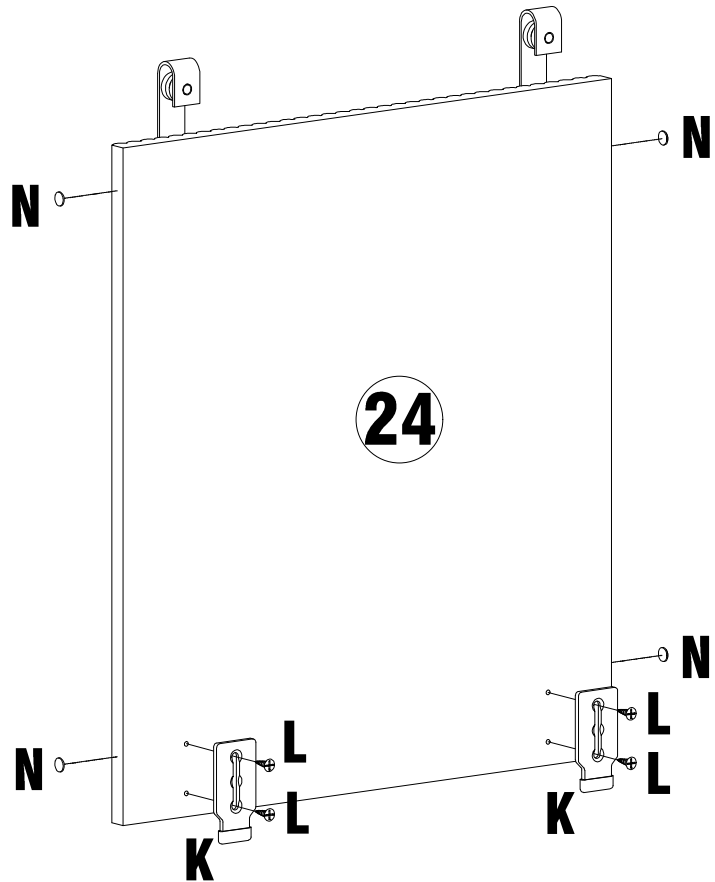

STEP 29

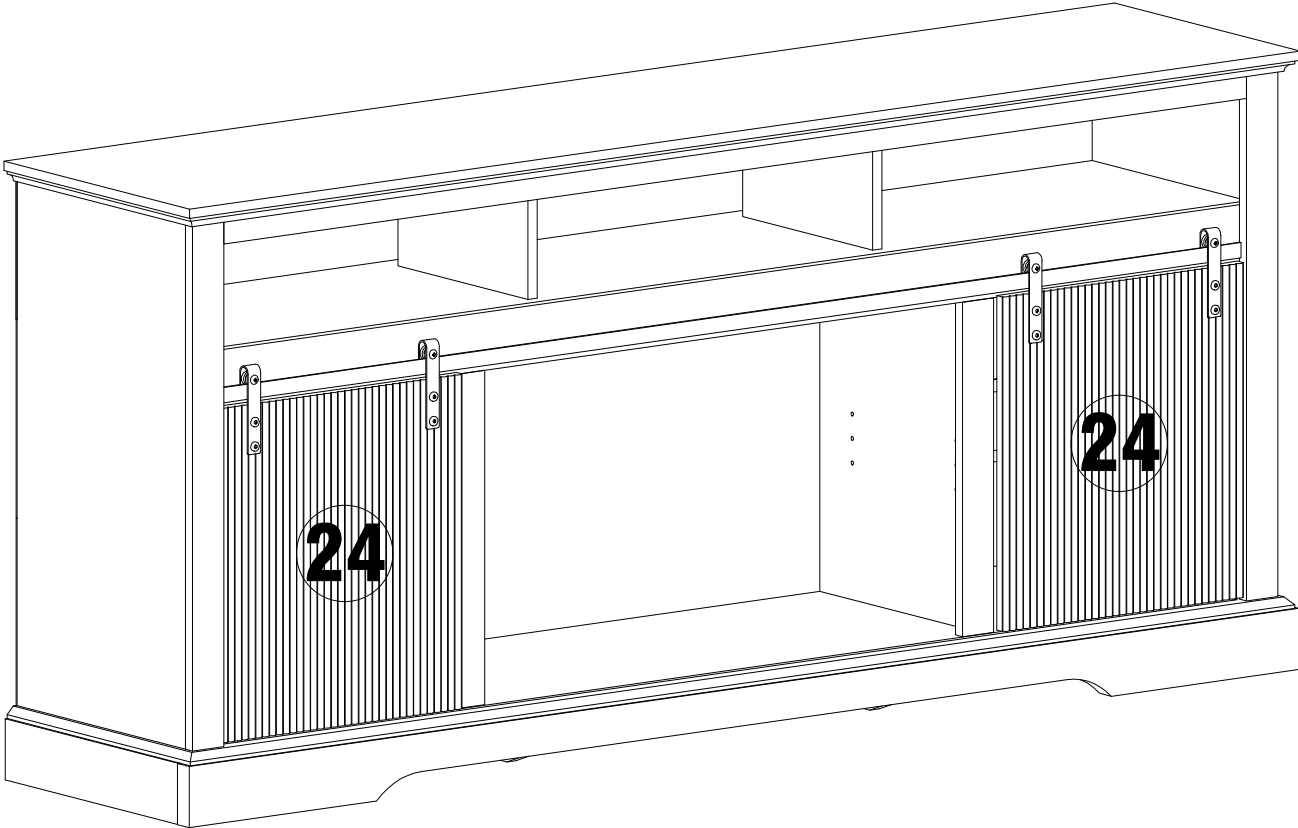
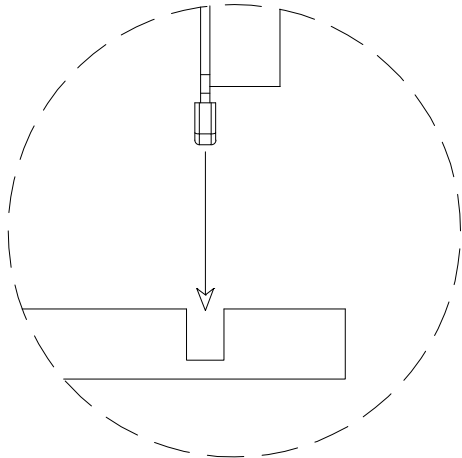
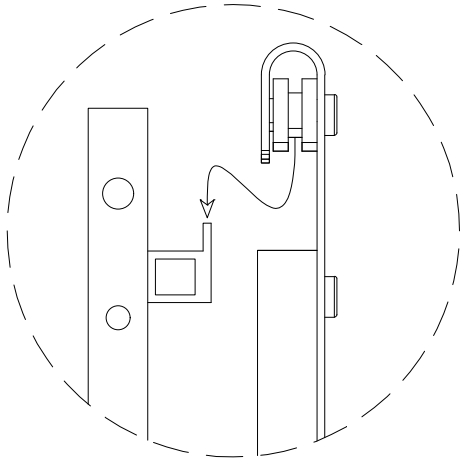

STEP 30

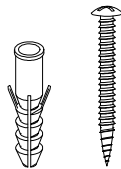
0  **X2**

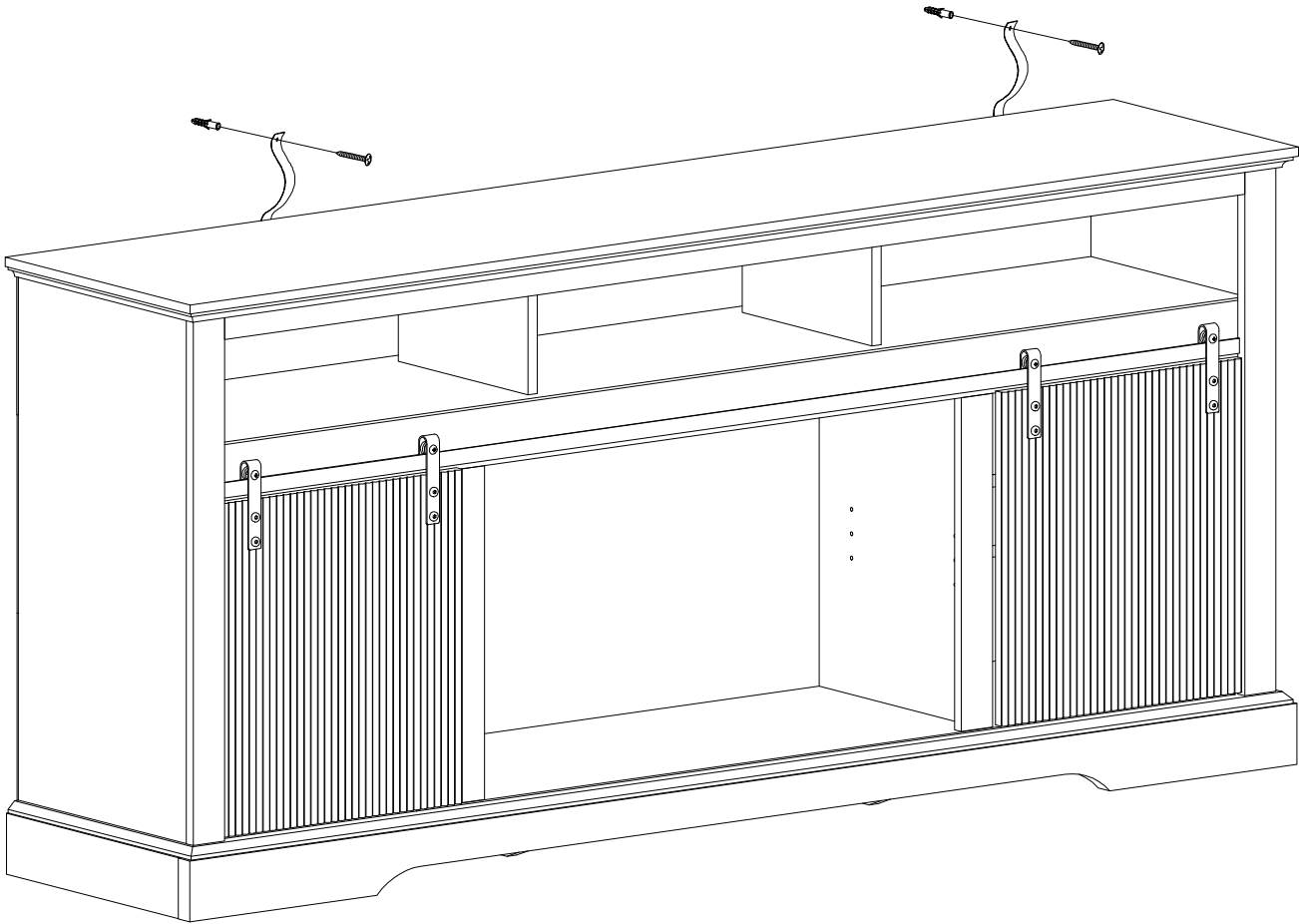
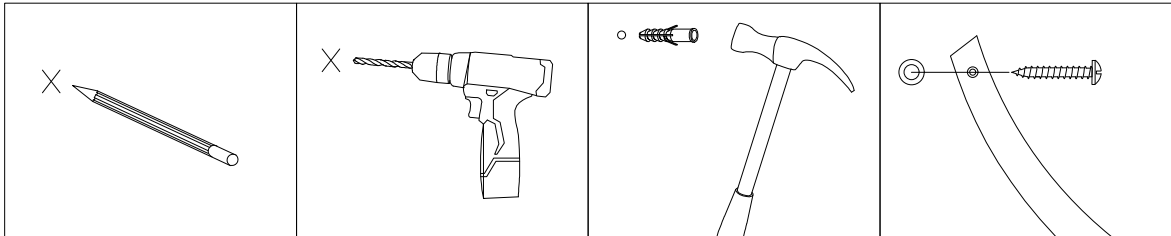

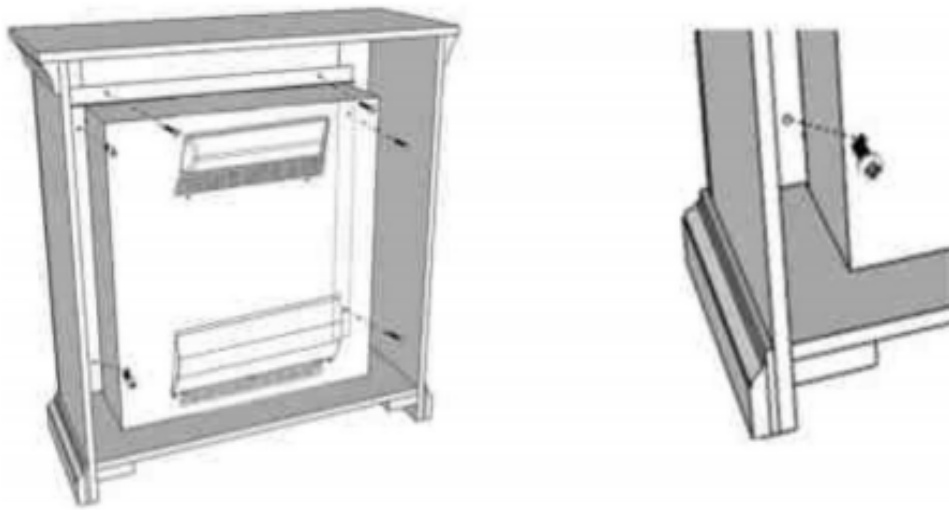

FIREPLACE INSTALLATION

If you decide to install the fireplace into the mantel, carefully set the unit from the back of the mantel and center it in the opening.

Check the alignment and attach the unit to the mantel by inserting screws through the drilled holes on the trim to the mantel.

NOTE: Do not attempt to install the unit from the front of the mantel. It will not fit.