

MIRRORED OPEN SHELF WARDROBE ASSEMBLY INTRUCTIONS BLACK WOOD GRAIN

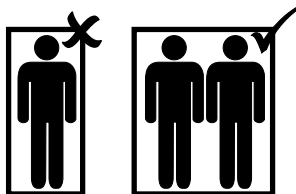
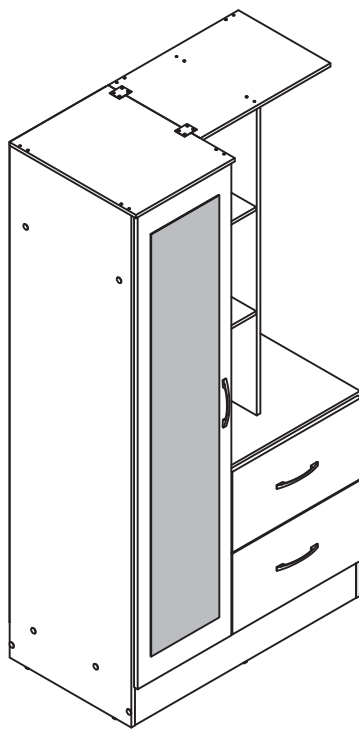

IMPORTANT FOR DOMESTIC USE ONLY

PLEASE READ BEFORE YOU CONTINUE FURTHER

CARE AND MAINTENANCE

After unpacking this product please keep the original packaging in case it needs to be returned for any reason.

- Please ensure all fittings and parts are present before commencing with assembly.
- Never drag or push products as this could cause damage to the joints making it inferior.
- We strongly recommend that you keep children away from your work area.
- We recommend that you lay a blanket or sheet on the floor to avoid damage to both your floor and the product.
- Assemble this product as close to its final position as possible.
- Do not place this product next to a radiator or in direct sunlight.
- Do not drag or push items across your high gloss furniture as this may cause the surface to scratch
- Wood is a natural product and may expand if subjected to damp and may shrink or crack if subjected to heat. Therefore it is recommended that room temperature is maintained, with no sudden temperature fluctuations.
- Make sure any spillage is wiped off immediately.
- Do not place hot or chilled items directly on to the surface, use a place mat or marking will occur.
- For general cleaning use a soft cotton or micro fibre cloth, and do not use detergents of any kind.
- From time to time it may be necessary to tighten fittings, regular inspections should be carried out.
- Do not place on a wet or damp floor as staining may occur to your floor.

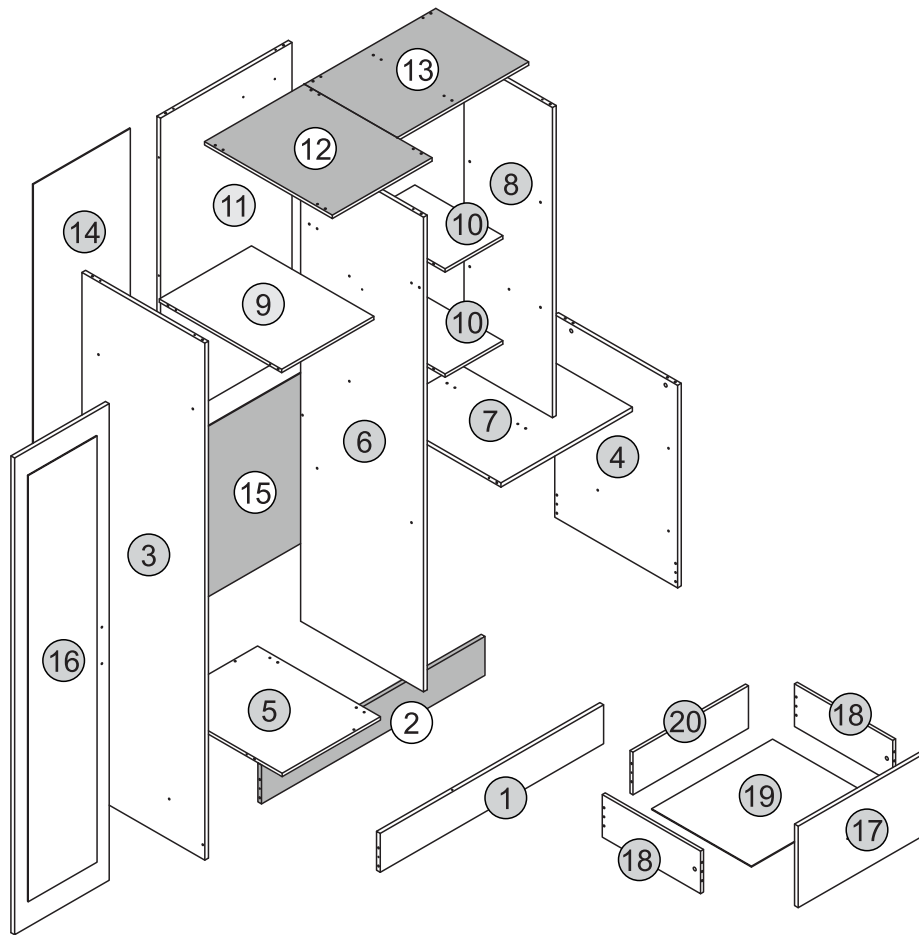

TOOLS REQUIRED

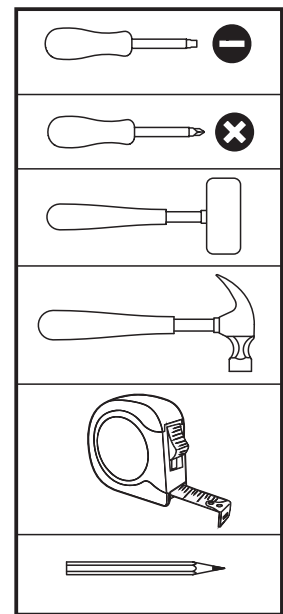









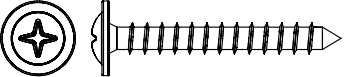
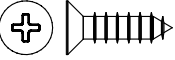
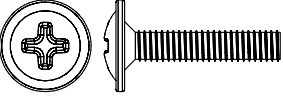

PARTS LIST

Please Note:
The below parts have all been stamped with the part number to help identify them during assembly

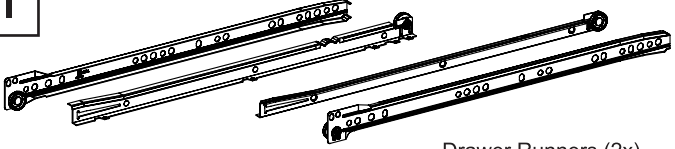
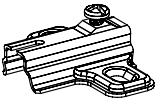
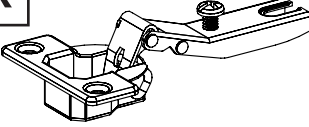
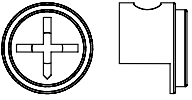
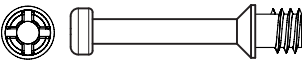
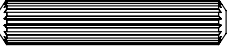
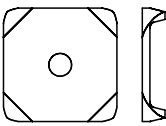
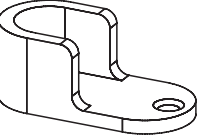
Part Number	Part Code	Part Description	Quantity	Carton
1	S100-101-152-DM1-01	Front Baseboard	1	2/2
2	S100-101-152-DM1-02	Back Baseboard	1	2/2
3	S100-101-152-DM1-03	Left Side Panel	1	1/2
4	S100-101-152-DM1-04	Right Side Panel	1	2/2
5	S100-101-152-DM1-05	Small Base Panel	1	2/2
6	S100-101-152-DM1-06	Left Division Panel	1	1/2
7	S100-101-152-DM1-07	Drawer Top Panel	1	2/2
8	S100-101-152-DM1-08	Division Panel	1	2/2
9	S100-101-152-DM1-09	Shelf	1	2/2
10	S100-101-152-DM1-10	External Shelf	2	2/2
11	S100-101-152-DM1-11	Back Panel	1	2/2
12	S100-101-152-DM1-12	Top Panel	1	2/2
13	S100-101-152-DM1-13	Large Top Panel	1	2/2
14	S100-101-152-DM1-14	Large Back Panel	1	1/2
15	S100-101-152-DM1-15	Small Back Panel	1	2/2
16	S100-101-152-DM1-16	Door	1	1/2
17	S100-101-152-DM1-17	Drawer Front	2	2/2
18	S100-101-152-DM1-18	Drawer Side	4	2/2
19	S100-101-152-DM1-19	Drawer Back Panel	2	2/2
20	S100-101-152-DM1-20	Drawer Bottom	2	1/2

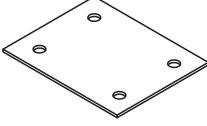
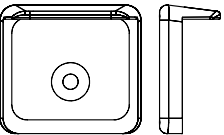
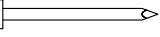
FITTINGS LIST

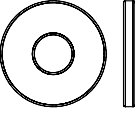
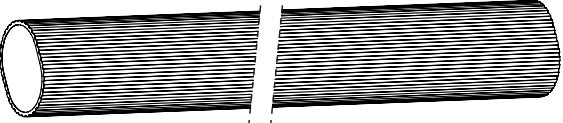
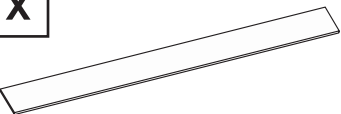
A  Flan Head Screw Ø3,5 x 12mm (6x) 1/+	B  Flat Head Screw Ø3,5 x 40mm (43x) 2/+	C  Flan Head Screw Ø3,5 x 30mm (2x) 1/+	
D  Flat Head Screw Ø4,0 x 14mm (38x) 2/+	E  Flan Head Screw Ø4,0 x 20mm (6x) 1/+	F  Flat Head Screw Ø6,0 x 8mm (8x) 2/+	G  Handle (3x)
H  Glue (3x)	I  Drawer Runners (2x)		J  Hinge Plate (3x)
K  Hinge (3x)	L  Cam Nut 12mm (6x) 1/+	M  Cam Bolt (6x) 1/+	N  Dowel Ø6,0 x 30mm (56x) 2/+
O  Back Panel Bracket (5x) 1/+	P  Hanging Rail Support (2x)	Q  Metalic Hook (2x)	R  Metalic Bracket (2x)
S  Plastic Foot (6x) 1/+	T  Nail 10 x 10 (80x) 5/+	U  Hole Plugs (30x) 2/+	V  Washer (4x) 1/+
W  Hanging Rail (1x)		X  Strap 200mm (2x)	

TIPS FOR FITTINGS CAM-LOCKS

WHEN FITTING CAM NUT. ENSURE STARTING POSITION IS CORRECT BEFORE YOU INSERT CONNECTING CAM BOLT TURN CLOCKWISE UNTIL SECURE

 ✓
 ↑
 CORRECT

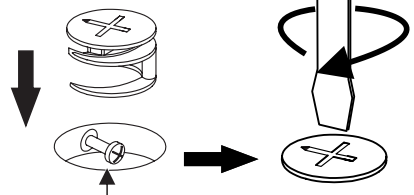

 ✗
 ↓
 WRONG



Cam bolt head needs to be in centre

CAMBOLT

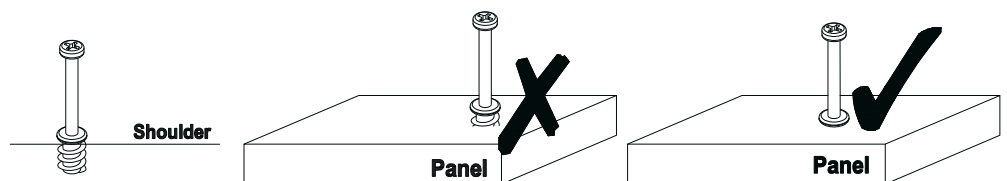
Tighten until shoulder is flush with panel. Do not overtighten or undertighten (see example beside)



STEP 1

PARTS REQUIRED

3 - LEFT SIDE PANEL x1

HARDWARE REQUIRED

D  08
Ø4,0 x 14mm

J  03

P  01

TOOLS REQUIRED

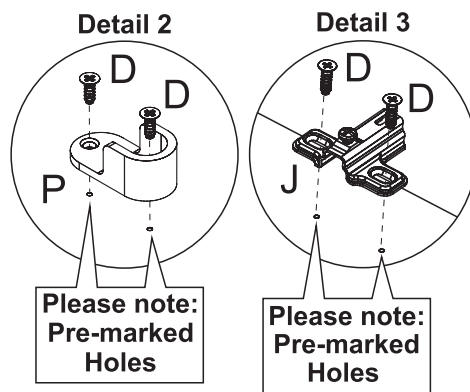
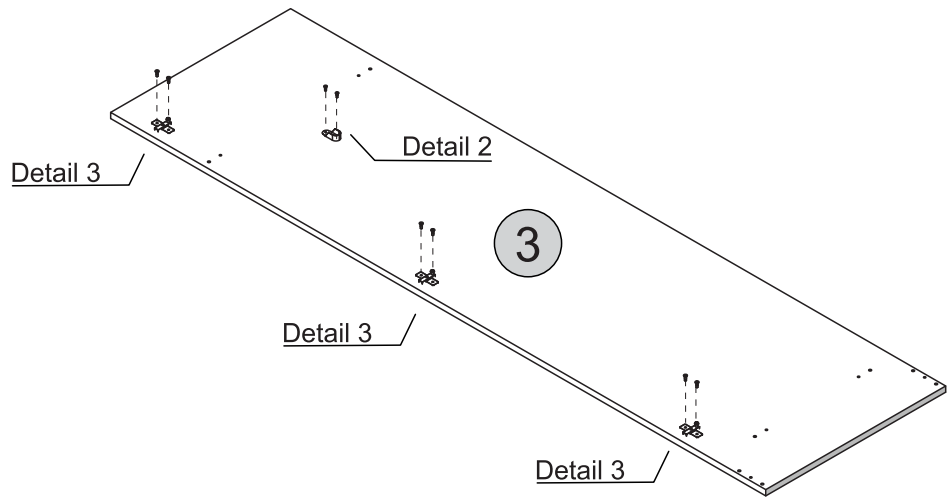
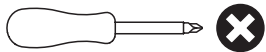

STEP 2

PARTS REQUIRED

3 - LEFT SIDE PANEL x1

HARDWARE REQUIRED

H  01
Glue

N  02
Ø6,0 x 30mm

S  02

T  02

TOOLS REQUIRED

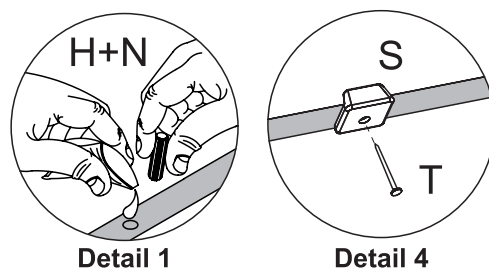
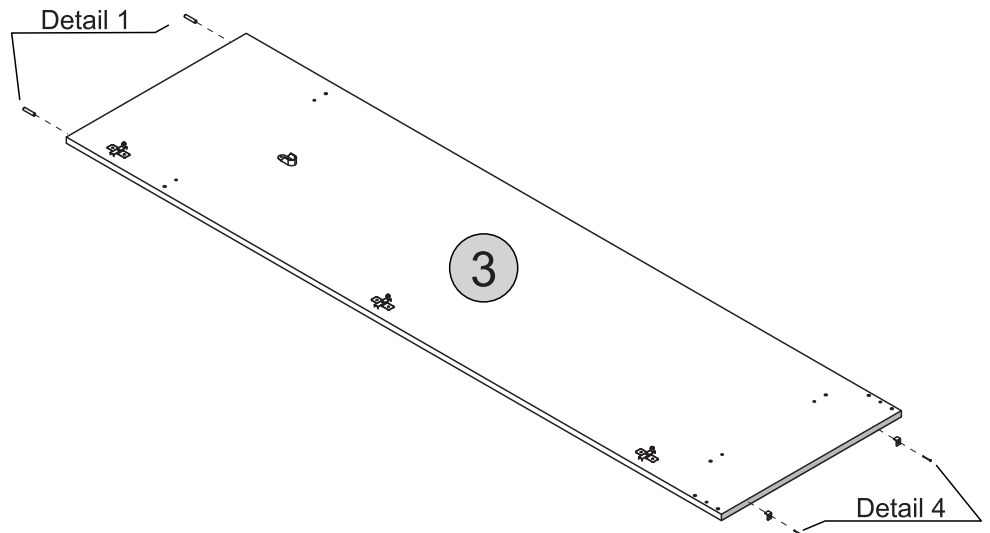
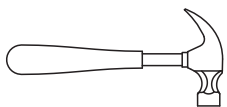

STEP 3

PARTS REQUIRED

6 - LEFT DIVISION PANEL x1

HARDWARE REQUIRED

D  02
Ø4,0 x 14mm

H  01
Glue

N  04
Ø6,0 x 30mm

P  01

TOOLS REQUIRED

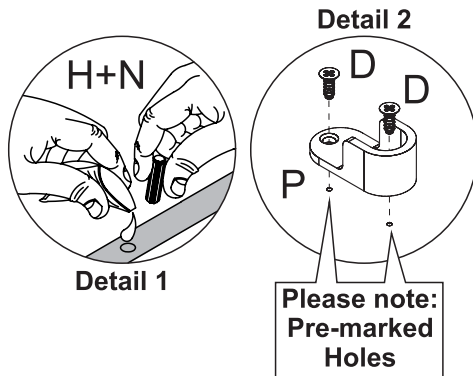
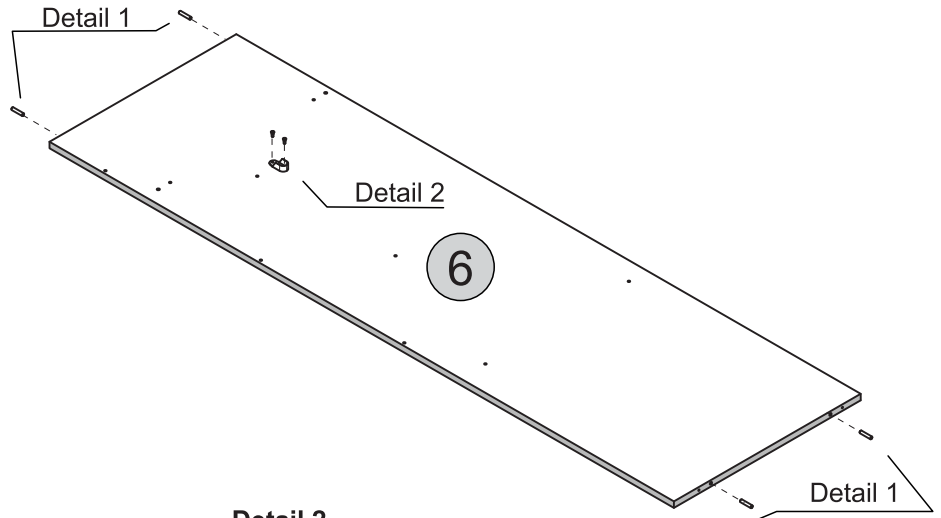
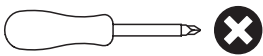

STEP 4

PARTS REQUIRED

6 - LEFT DIVISION PANEL x1

HARDWARE REQUIRED

F  04
Ø6,0 x 8mm

I  02
Left

TOOLS REQUIRED

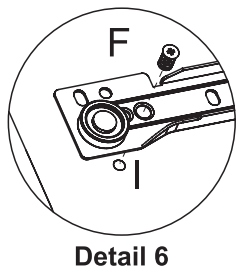
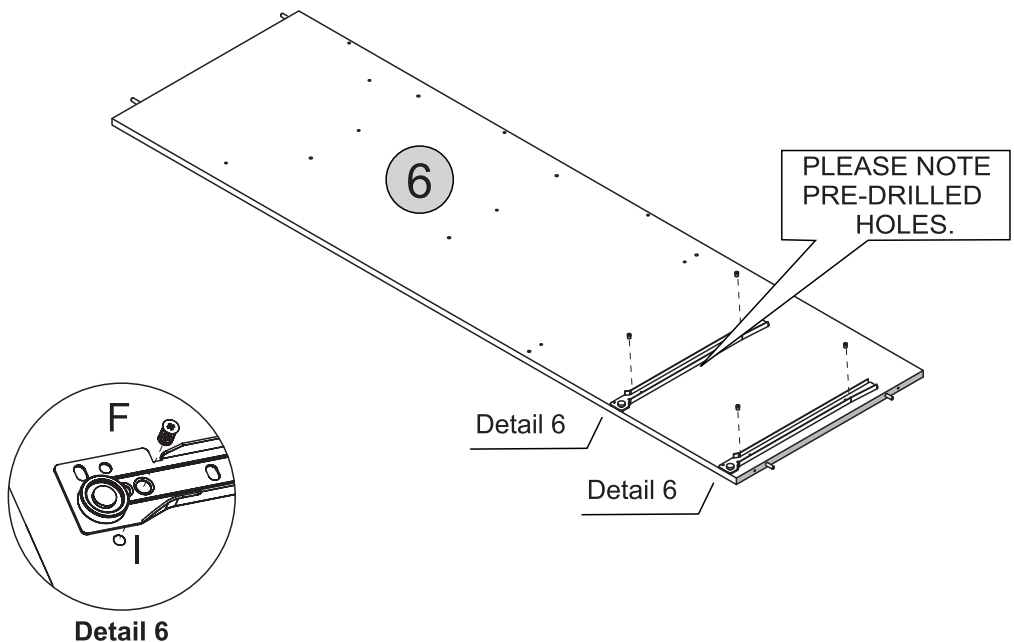
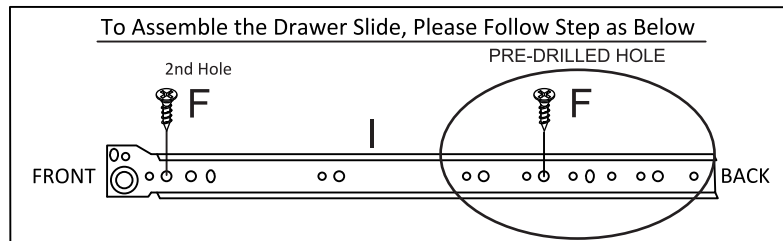
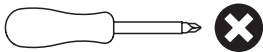

STEP 5

PARTS REQUIRED

4 - RIGHT SIDE PANEL x1

HARDWARE REQUIRED

F  04
Ø6,0 x 8mm

H  01

I  02

N  02
Ø6,0 x 30mm

S  02

T  02

TOOLS REQUIRED

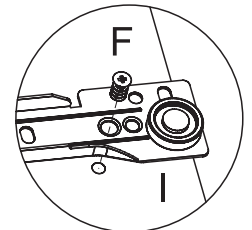
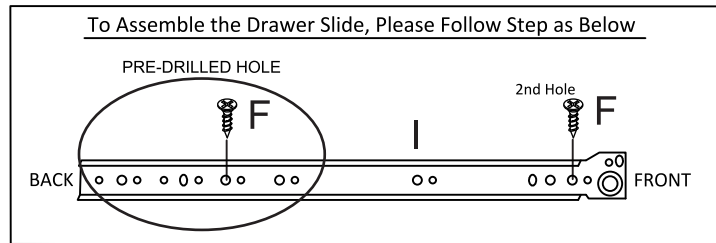
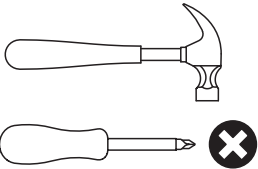

Detail 6

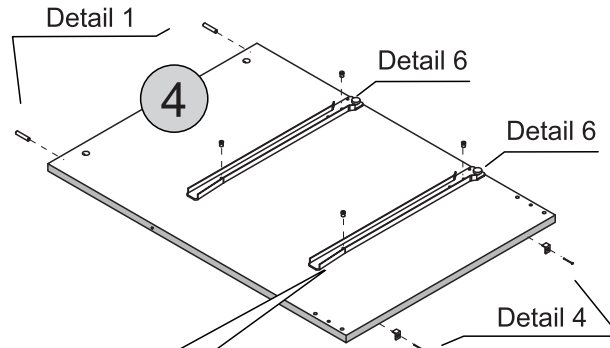

PLEASE NOTE
PRE-DRILLED
HOLES.



Detail 1

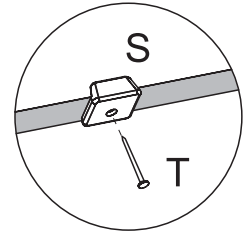

Detail 4

STEP 6

PARTS REQUIRED

5 - SMALL BASE PANEL x1

8 - DIVISION PANEL x1

HARDWARE REQUIRED

H  01

N  06
Ø6,0 x 30mm

TOOLS REQUIRED

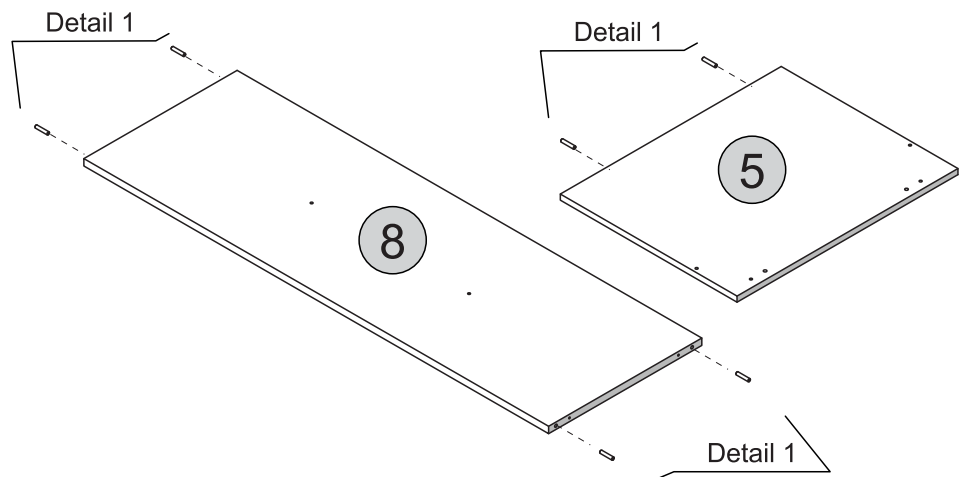

Detail 1

STEP 7

PARTS REQUIRED

1 - FRONT BASEBOARD x1

2 - BACK BASEBOARD x1

9 - SHELF x1

HARDWARE REQUIRED

H  01

N  12
Ø6,0 x 30mm

S  02

T  02

TOOLS REQUIRED

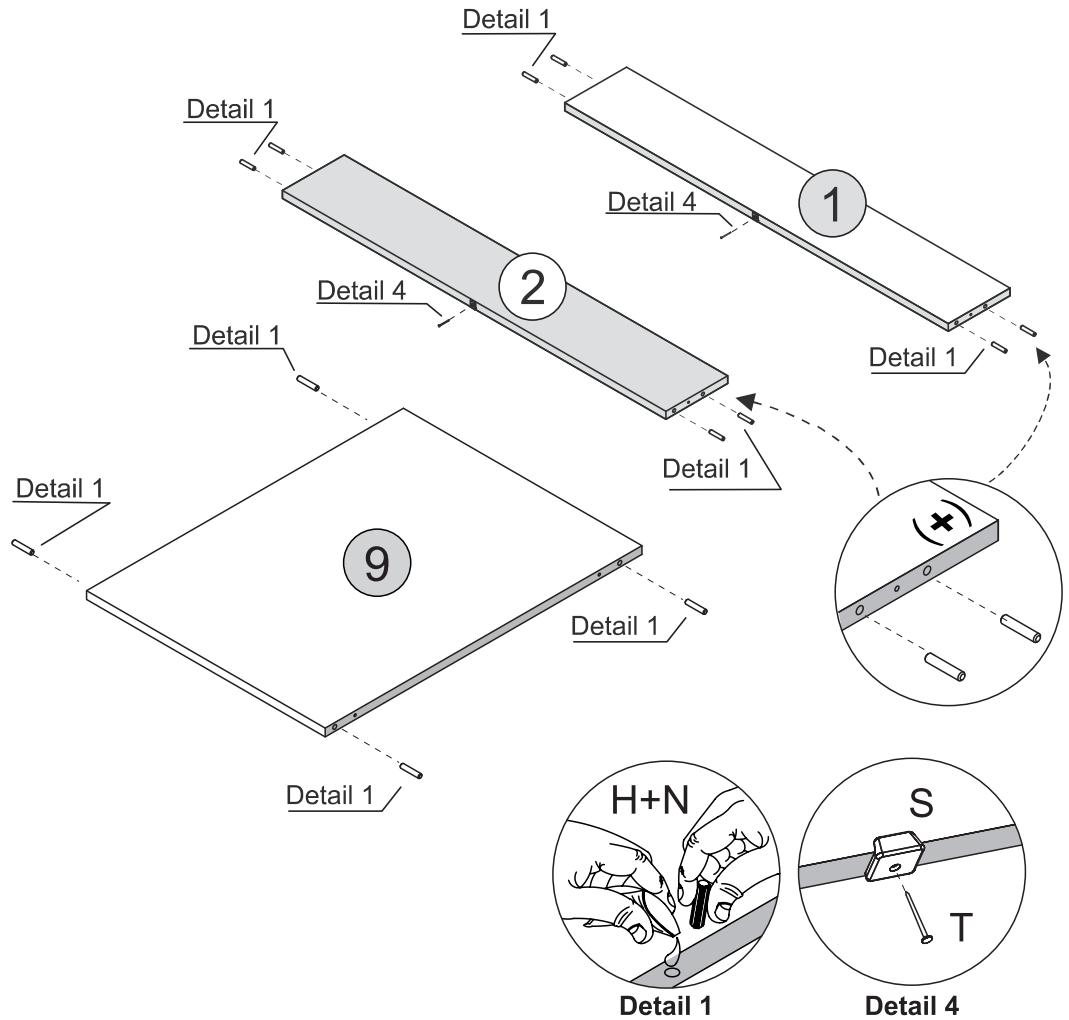
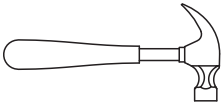

STEP 8

PARTS REQUIRED

10 - EXTERNAL SHELF x2

11 - BACK PANEL x1

HARDWARE REQUIRED

D  02
Ø4,0 x 14mm

H  01

N  12
Ø6,0 x 30mm

Q  02

TOOLS REQUIRED

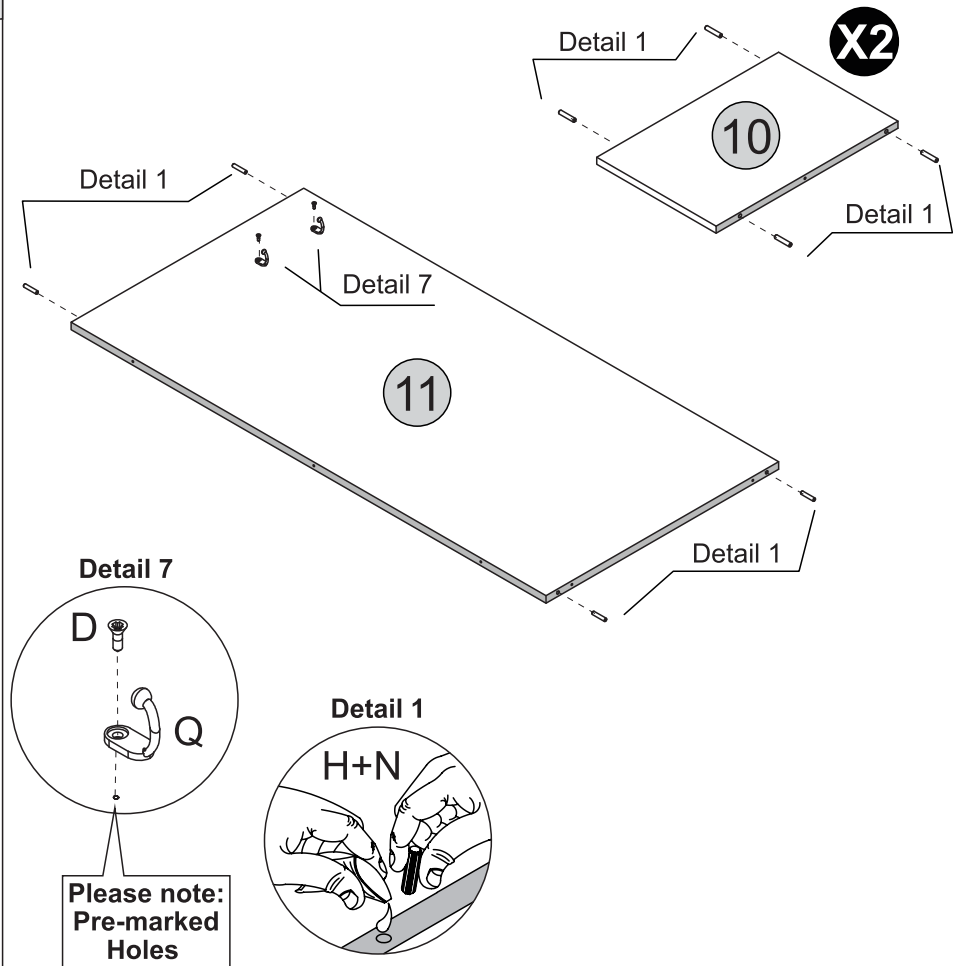
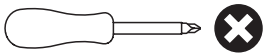

STEP 9

PARTS REQUIRED

7 - DRAWER TOP PANEL x1

HARDWARE REQUIRED

H  01

N  Ø6,0 x 30mm 02

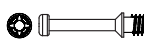
M  02

TOOLS REQUIRED

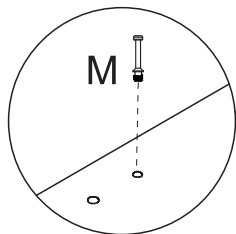
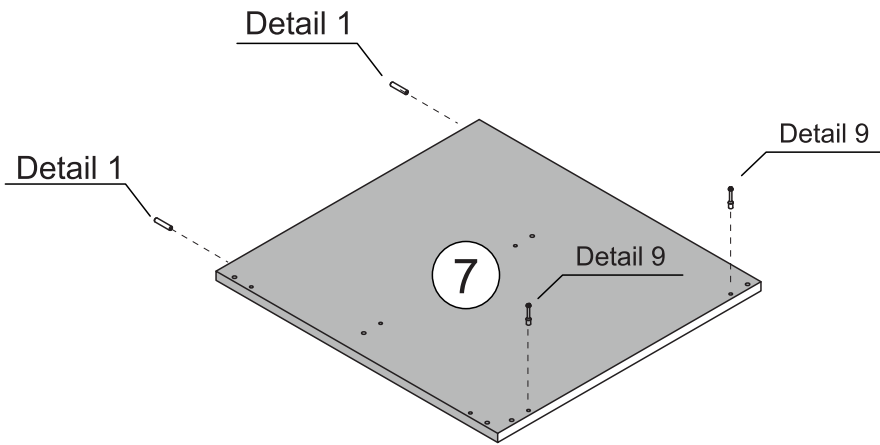
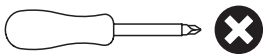

Detail 9

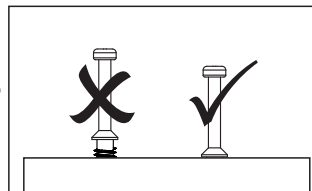

Detail 1

STEP 10

PARTS REQUIRED

5 - SMALL BASE PANEL x1

6 - LEFT DIVISION PANEL x1

9 - SHELF x1

HARDWARE REQUIRED

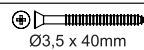
B  Ø3,5 x 40mm 04

H  01

TOOLS REQUIRED

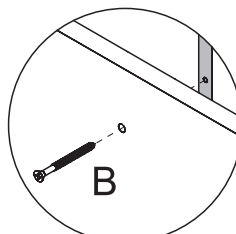
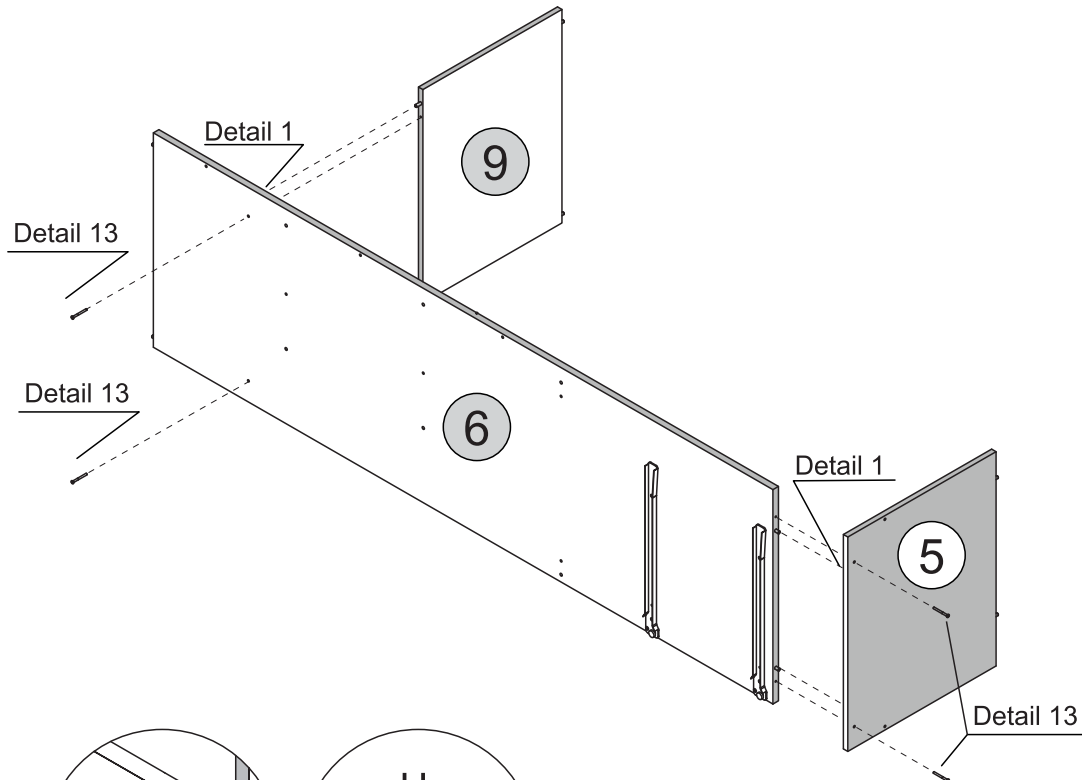
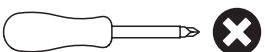

Detail 13

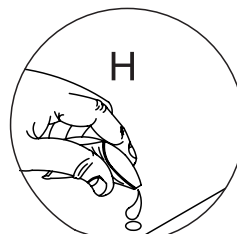

Detail 1

STEP 11

PARTS REQUIRED

3 - LEFT SIDE PANEL x1

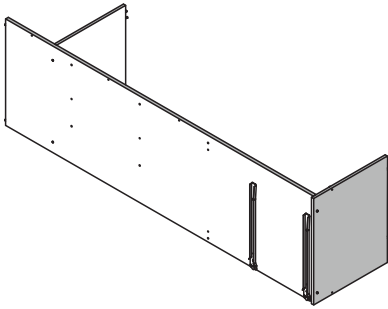

HARDWARE REQUIRED

B  04
Ø3,5 x 40mm

H  01
Glue

TOOLS REQUIRED

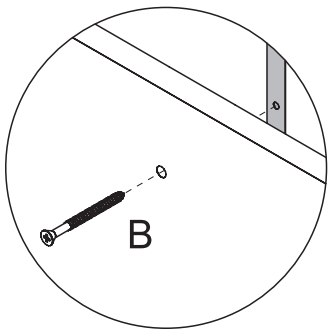
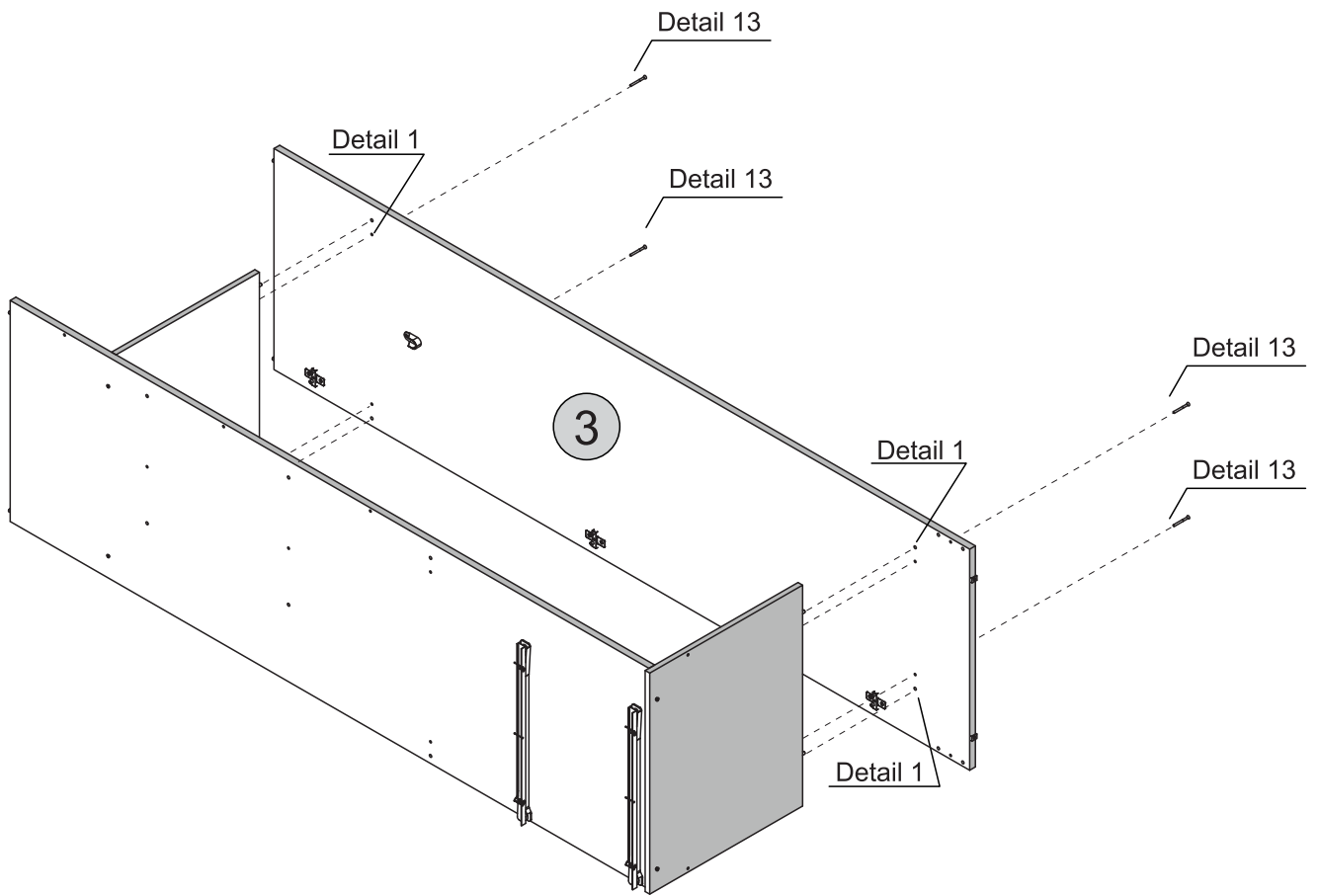
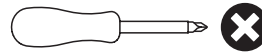

Detail 13

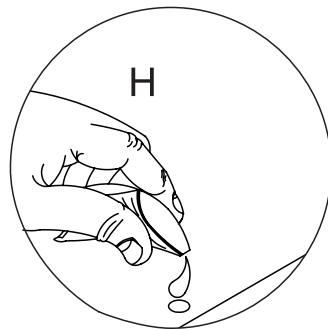

Detail 1

STEP 12

PARTS REQUIRED

7 - DRAWER TOP PANEL x1

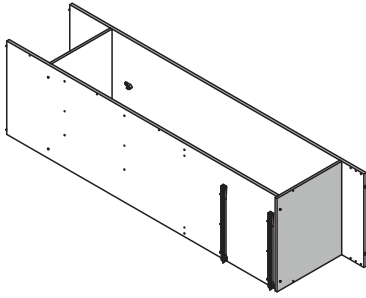

HARDWARE REQUIRED

B  02
Ø3,5 x 40mm

H  01

TOOLS REQUIRED

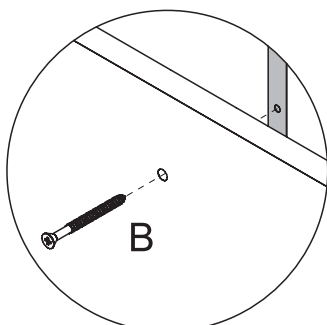
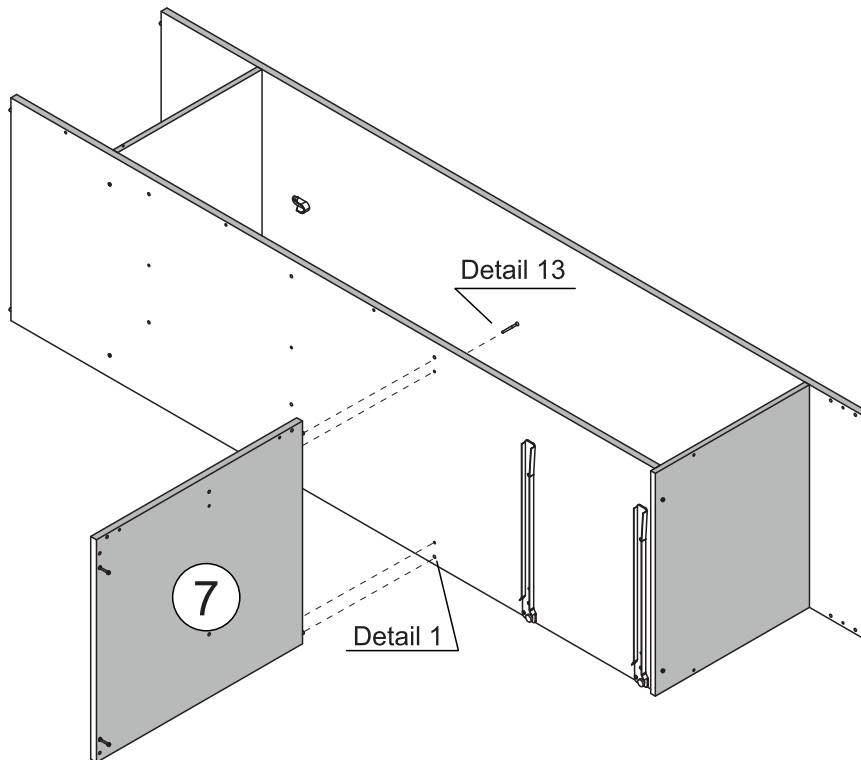
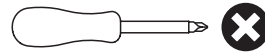

Detail 13

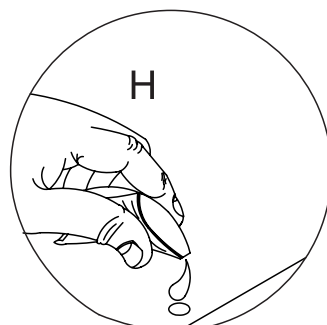

Detail 1

STEP 13

PARTS REQUIRED

4 - RIGHT SIDE PANEL x1

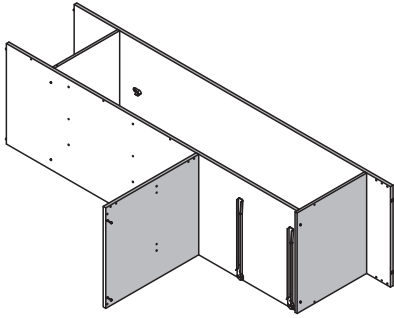

HARDWARE REQUIRED

H  01

L  02

TOOLS REQUIRED

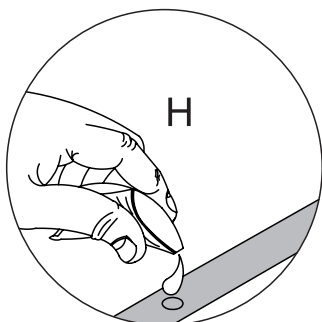
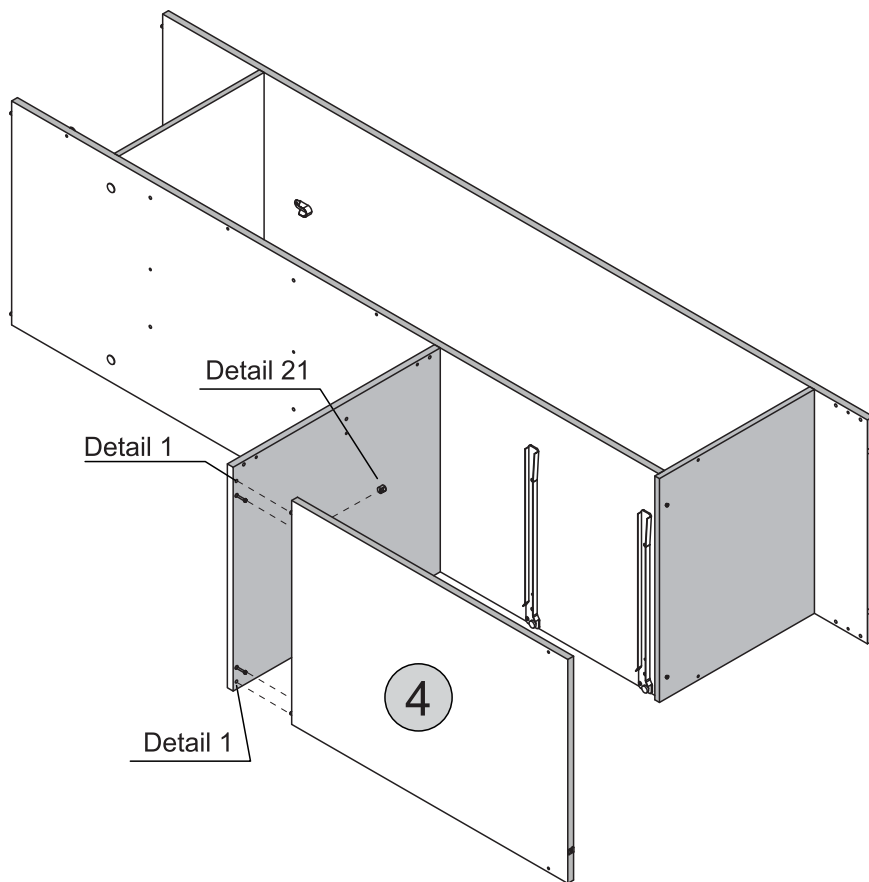
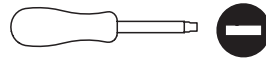

Detail 1

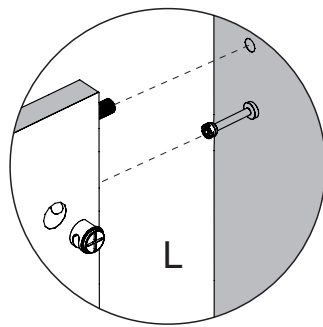

Detail 21

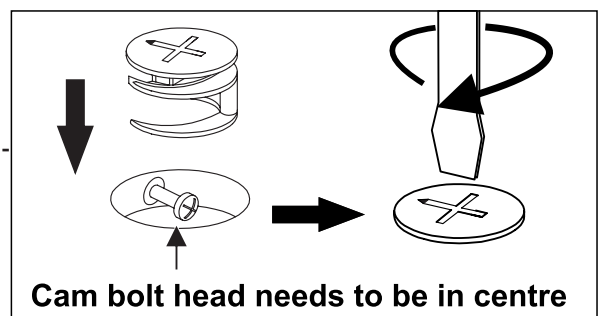

STEP 14

PARTS REQUIRED

1 - FRONT BASEBOARD x1

2 - BACK BASEBOARD x1

HARDWARE REQUIRED

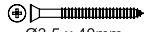
B  06
Ø3,5 x 40mm

H  01
Glue

TOOLS REQUIRED

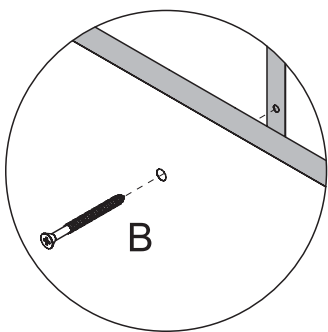
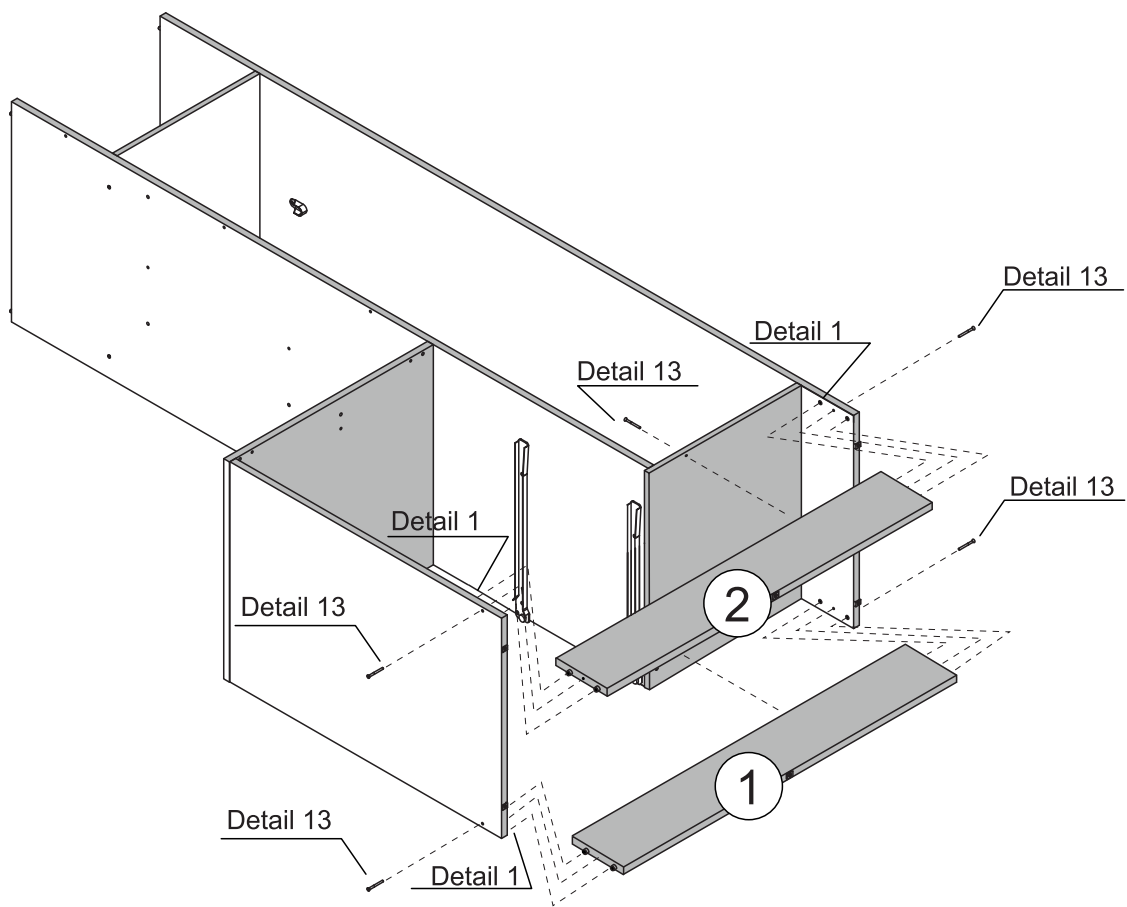
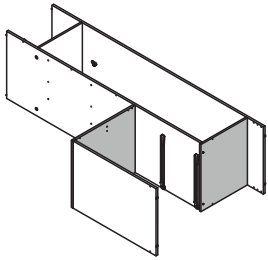

Detail 13

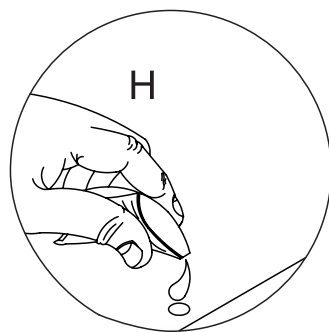

Detail 1

STEP 15

PARTS REQUIRED

10 - EXTERNAL SHELF x2

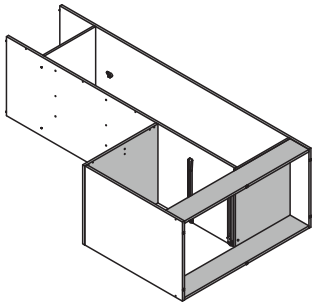

HARDWARE REQUIRED

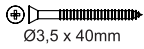
B  02
Ø3,5 x 40mm

H  01
Glue

TOOLS REQUIRED

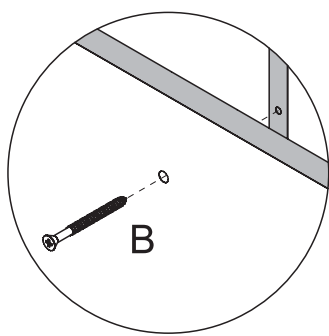
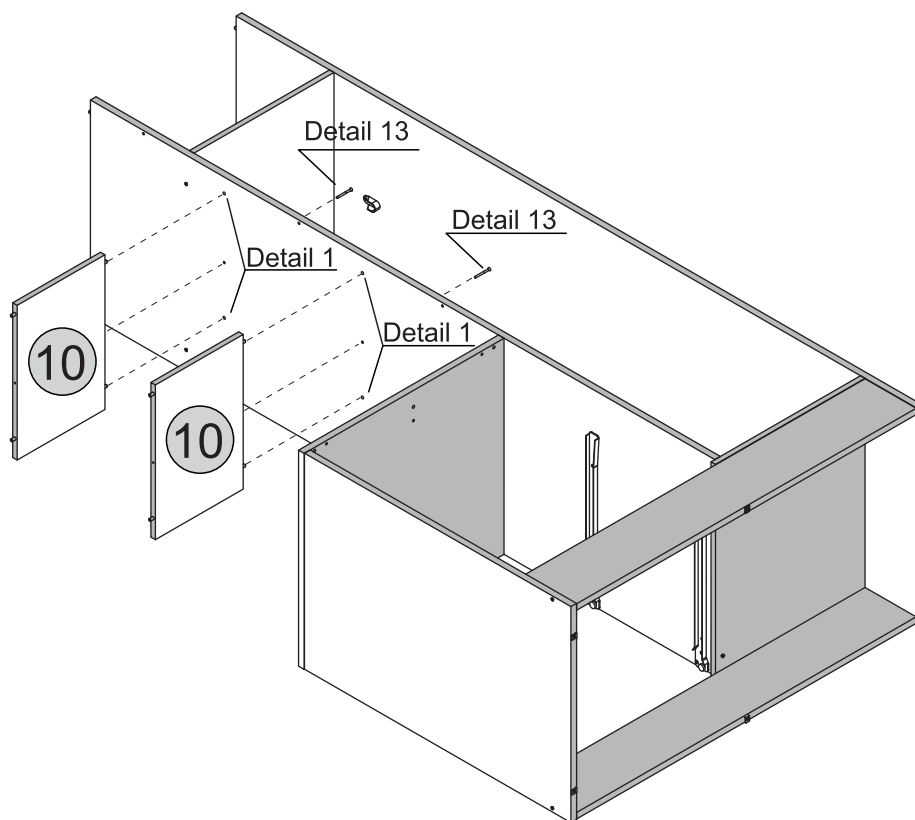
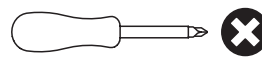

Detail 13

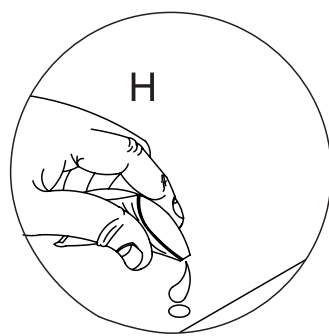

Detail 1

STEP 16

PARTS REQUIRED

8 - DIVISION PANEL x1

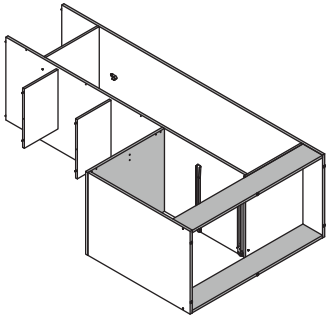

HARDWARE REQUIRED

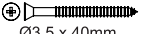
B  04
Ø3,5 x 40mm

H  01
Glue

TOOLS REQUIRED

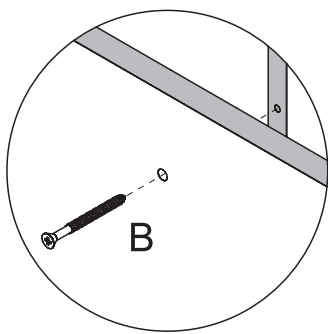
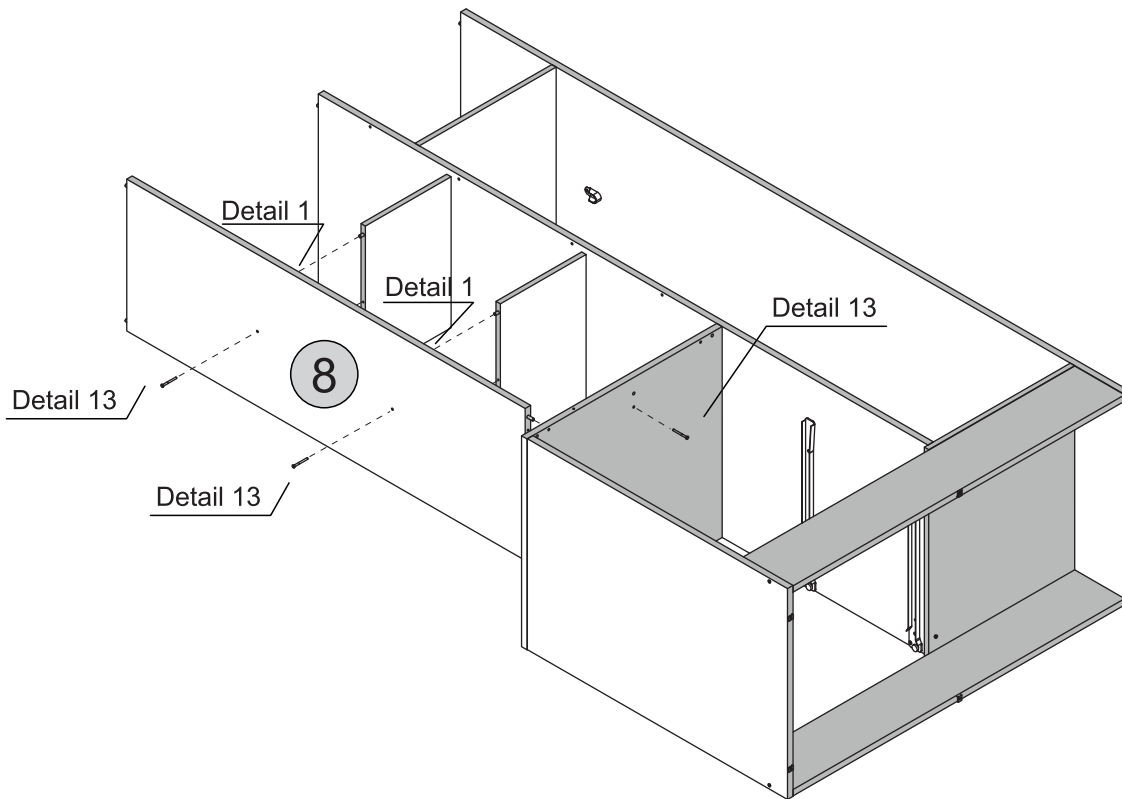
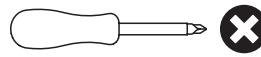

Detail 13

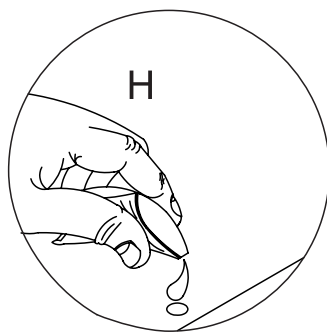

Detail 1

STEP 17

PARTS REQUIRED

11 - BACK PANEL x1

HARDWARE REQUIRED

B  06
Ø3,5 x 40mm

H  01
Glue

TOOLS REQUIRED

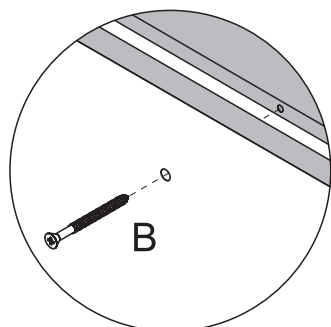
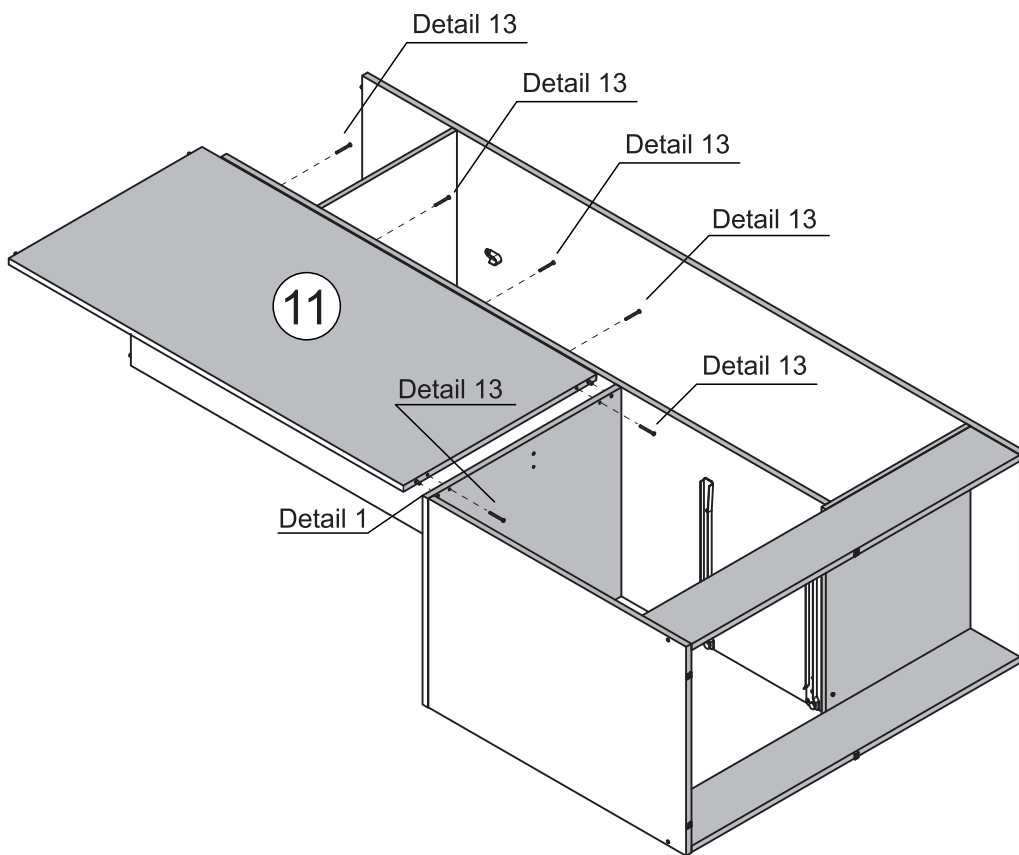
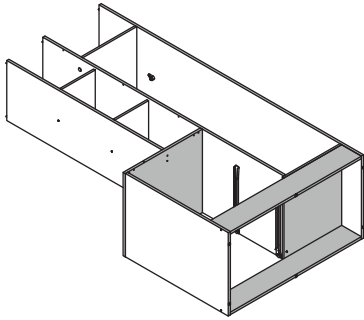
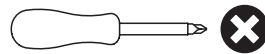

Detail 13

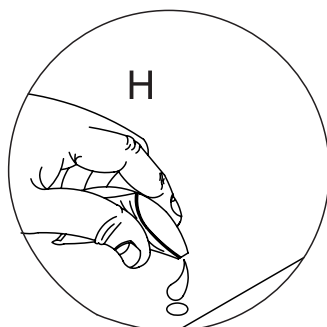

Detail 1

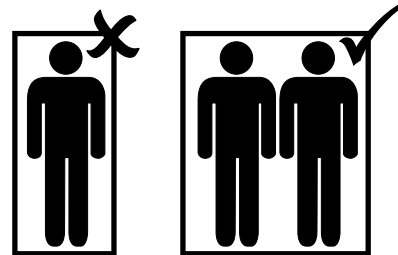

*You should assemble this step with two people

STEP 18

PARTS REQUIRED

12 - TOP PANEL x1

HARDWARE REQUIRED

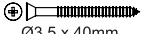
B  04
Ø3,5 x 40mm

H  01
Glue

TOOLS REQUIRED

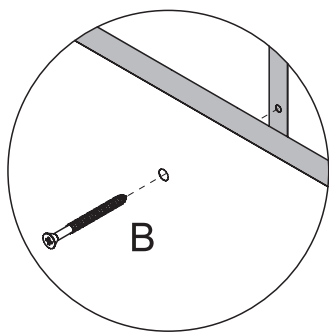
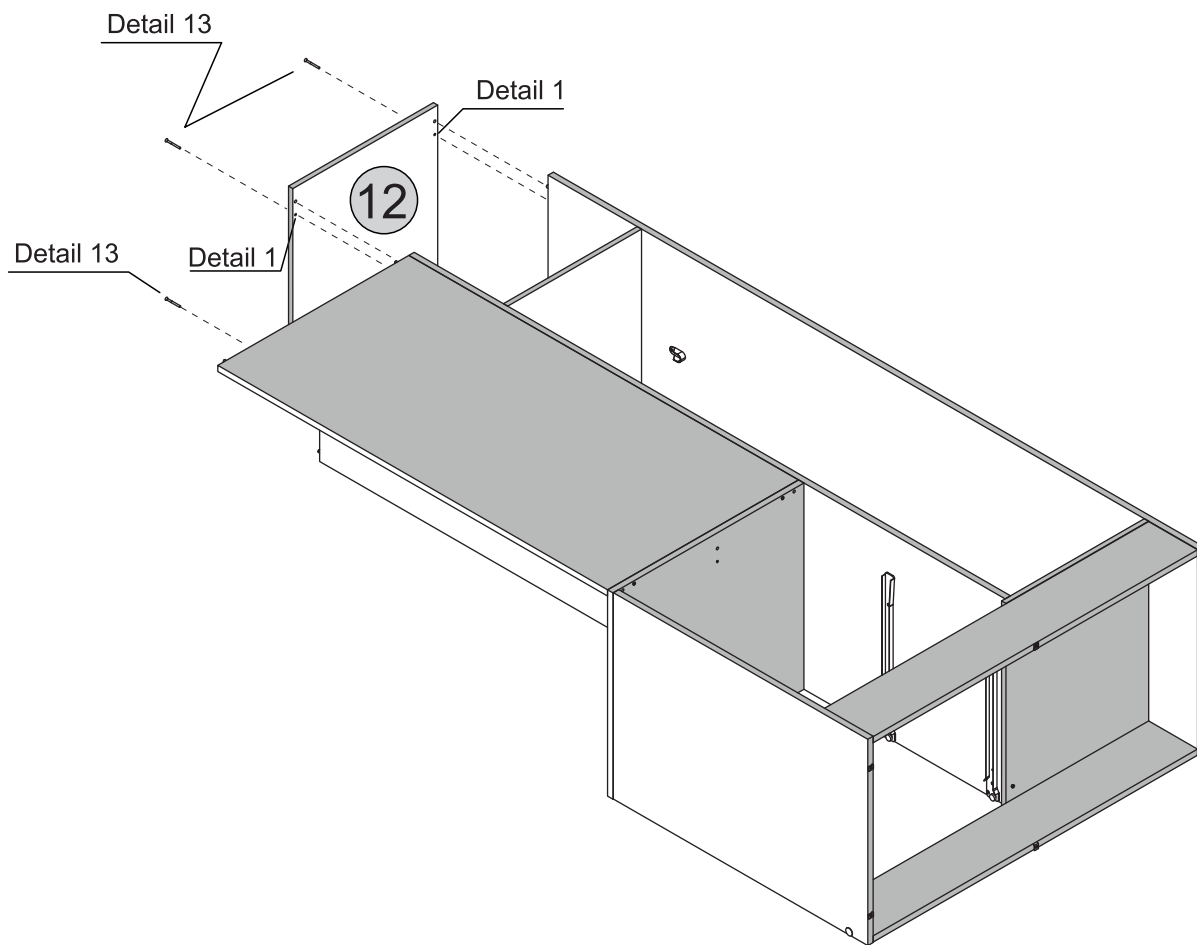
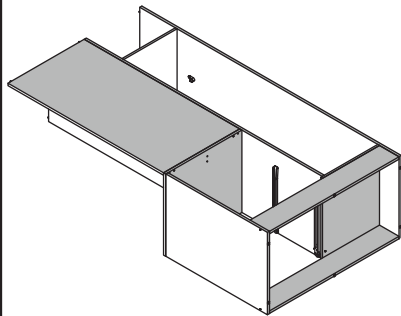
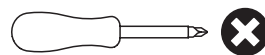

Detail 13

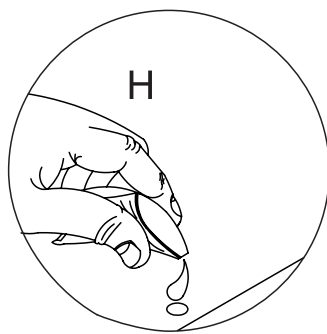

Detail 1

STEP 19

PARTS REQUIRED

13 - LARGE TOP PANEL x1

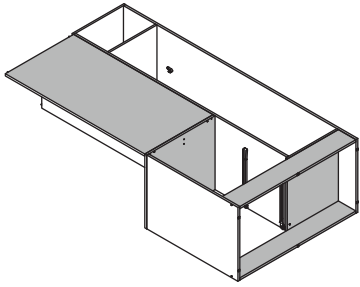

HARDWARE REQUIRED

B  04
Ø3,5 x 40mm

H  01
Glue

TOOLS REQUIRED

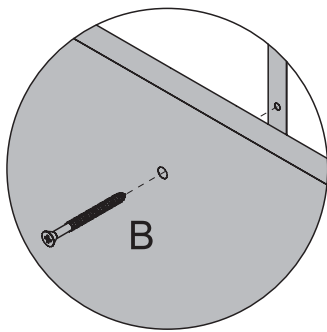
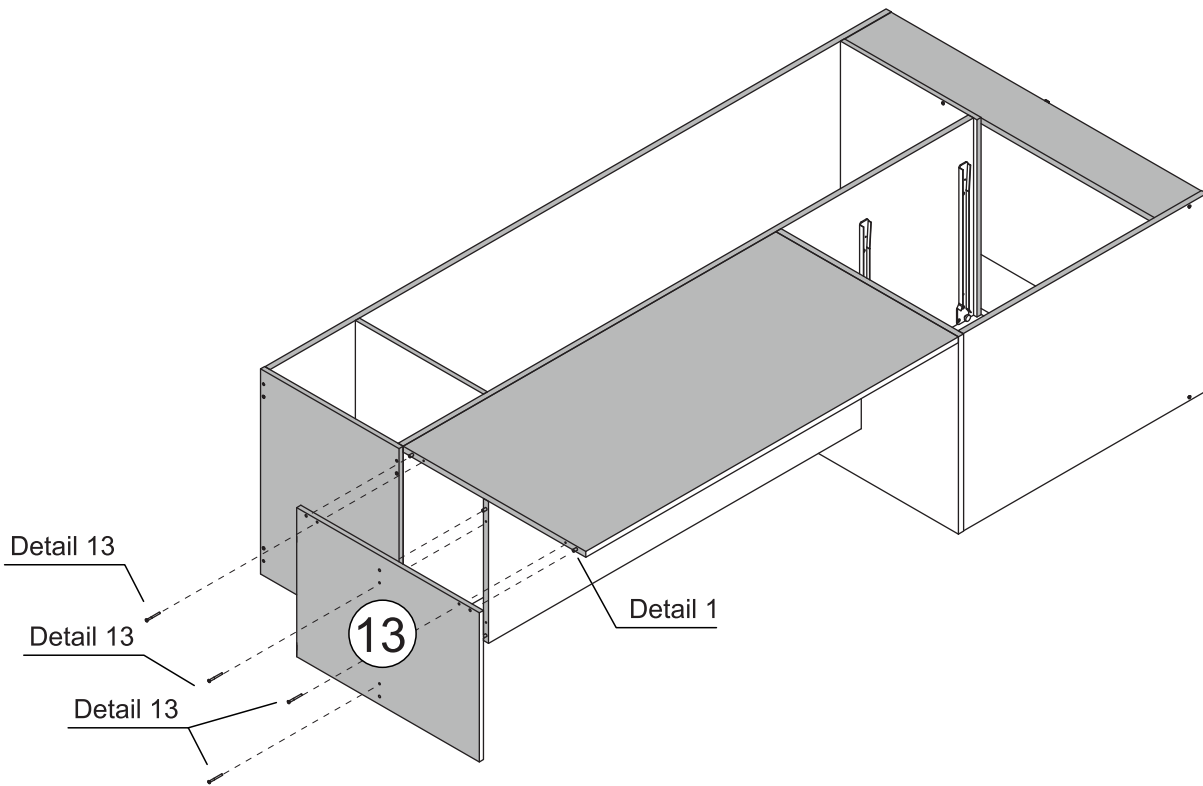
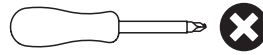

Detail 13

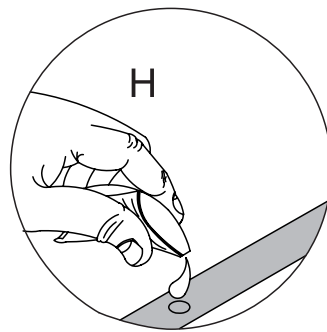



Detail 1

STEP 20

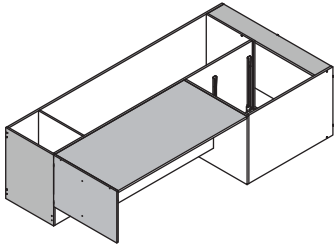
PARTS REQUIRED



HARDWARE REQUIRED

D	 08 Ø4,0 x 14mm
R	 02

TOOLS REQUIRED

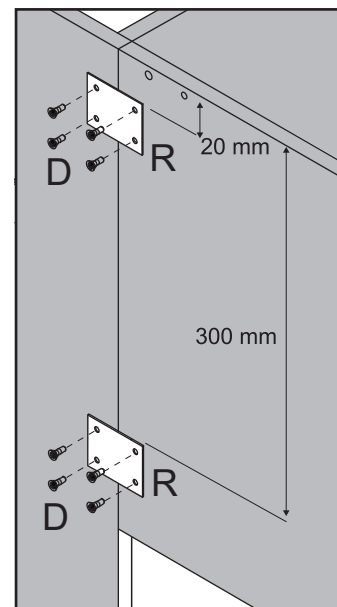
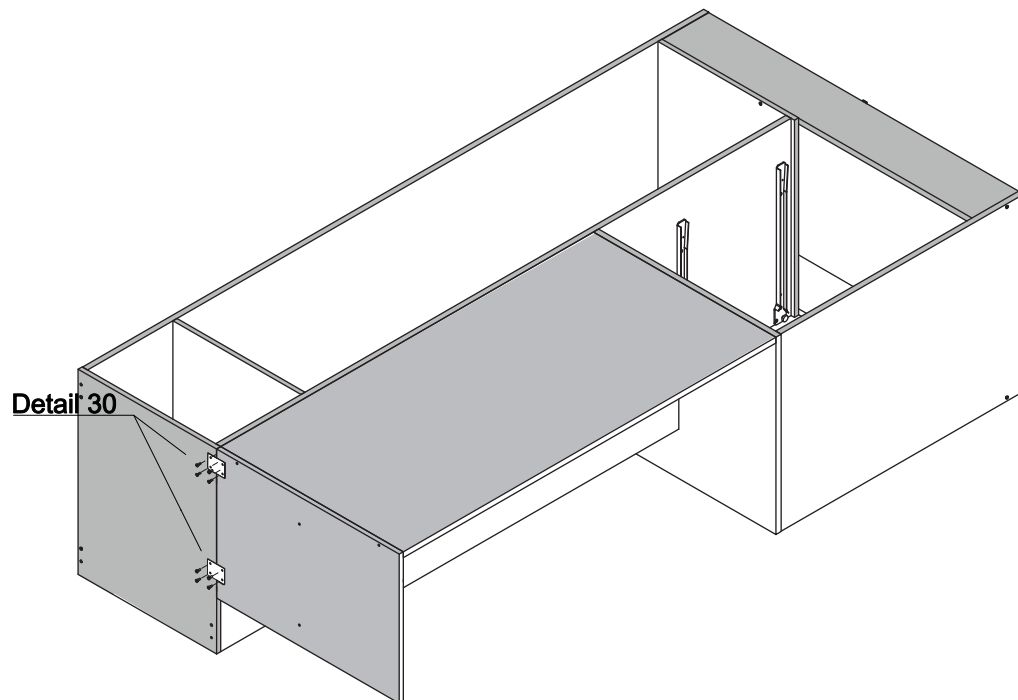
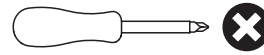

STEP 21

PARTS REQUIRED

14 - LARGE BACK PANEL x1

15 - SMALL BACK PANEL x1

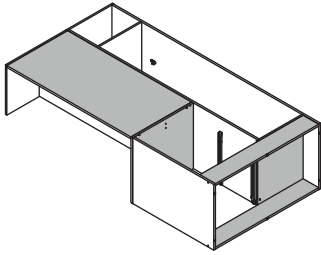

HARDWARE REQUIRED

O  05

T  54

TOOLS REQUIRED

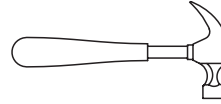

*Part 14 must be lined up on the edge of part 12

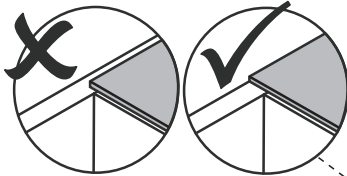

* For your future reference Order Number should be here.

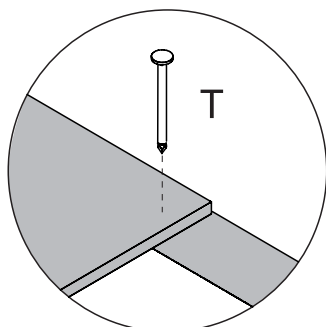
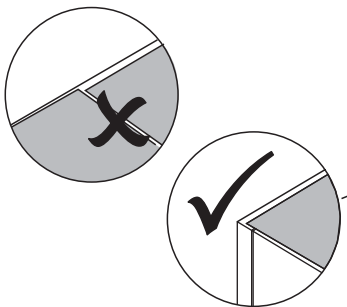
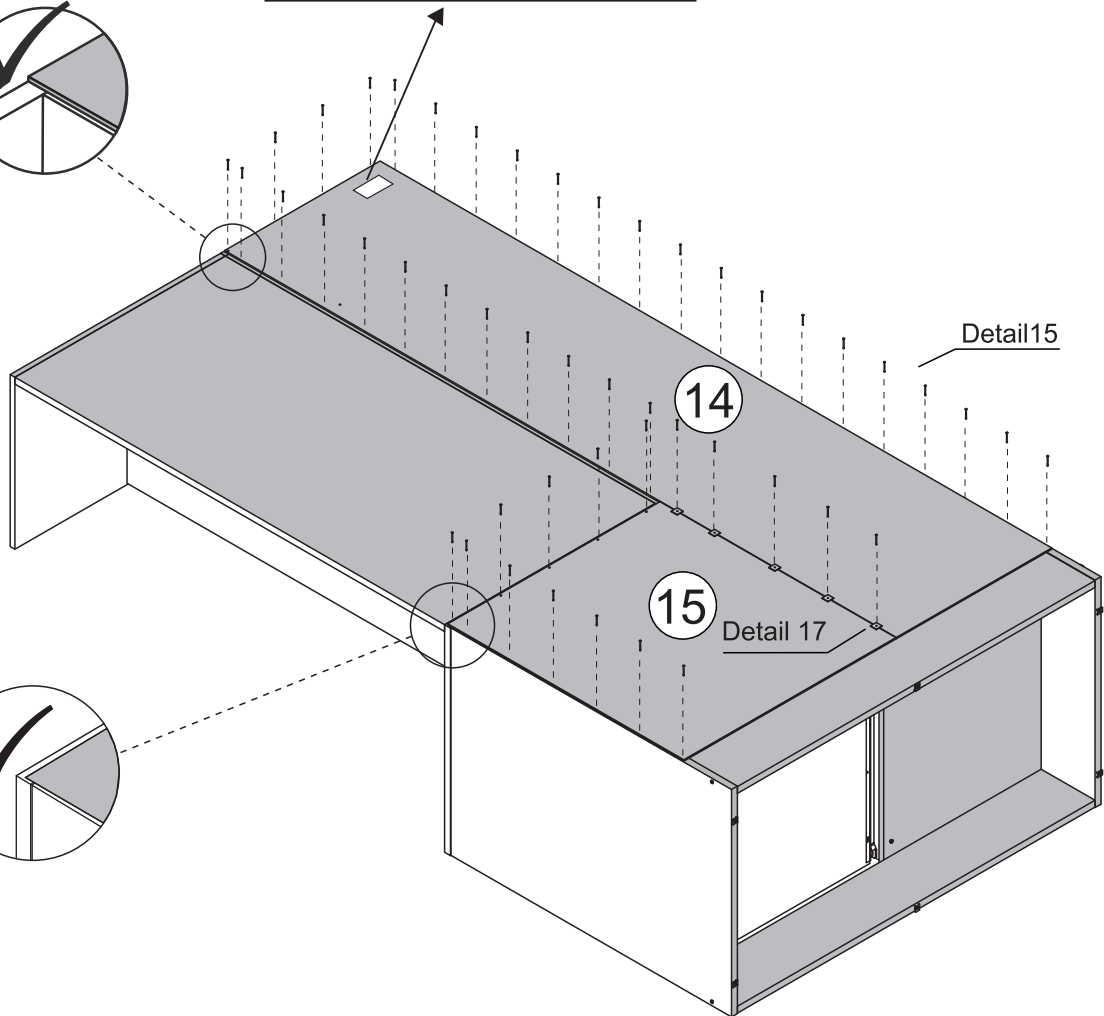

Detail 15

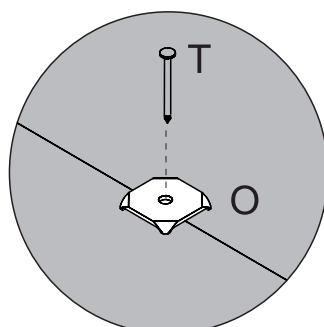

Detail 17

STEP 22

PARTS REQUIRED

14 - LARGE BACK PANEL x1

15 - SMALL BACK PANEL x1

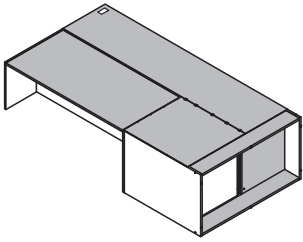

HARDWARE REQUIRED

A  06

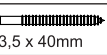
B  03

T  02

TOOLS REQUIRED

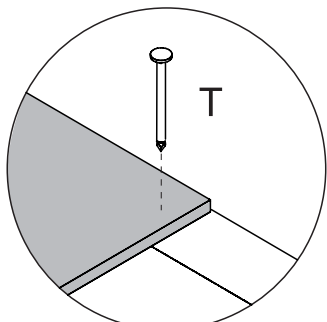
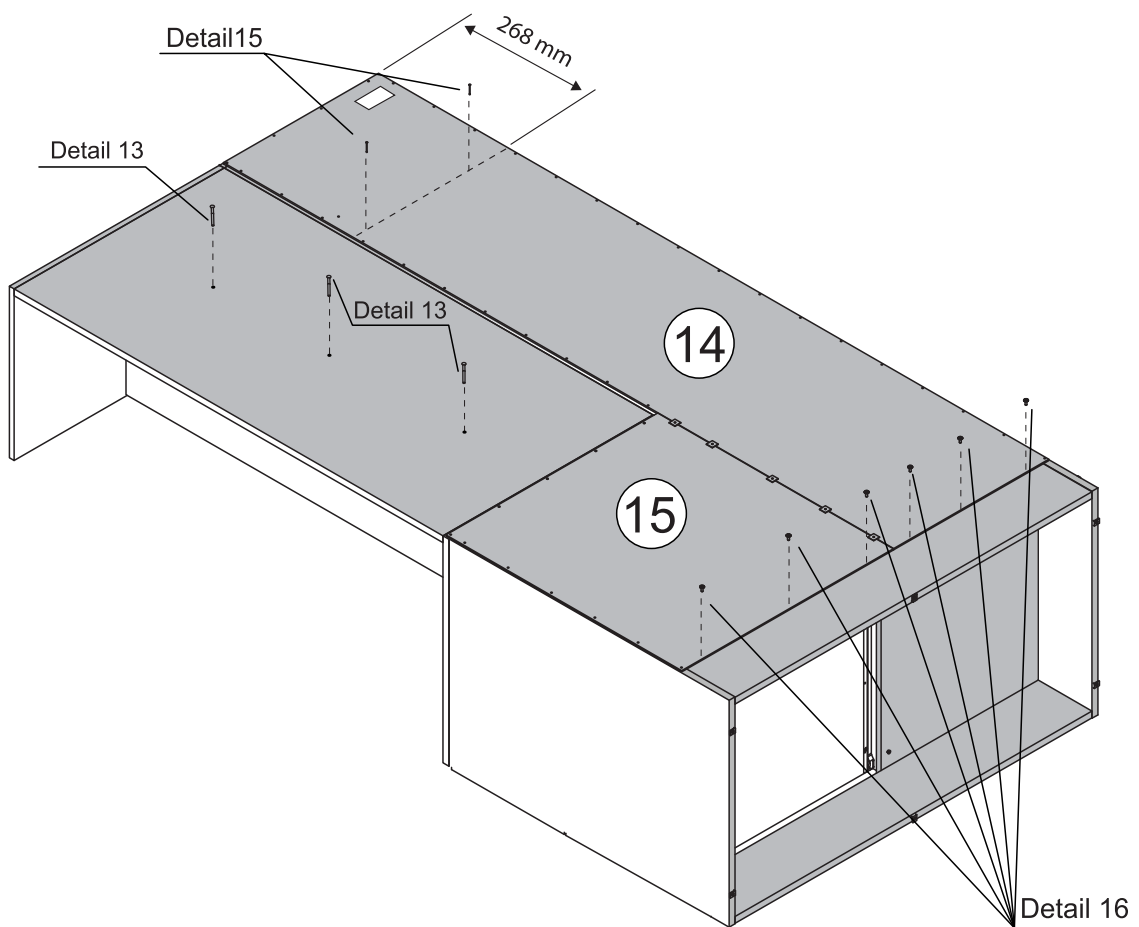
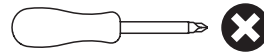
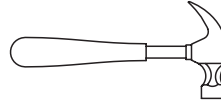

Detail 15

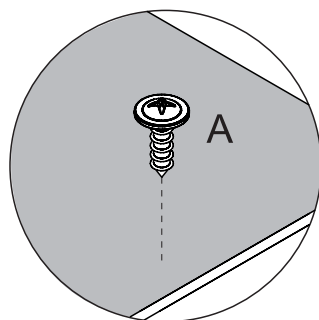

Detail 16

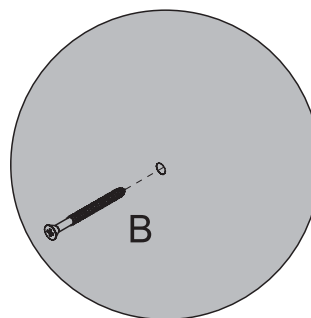

Detail 13

STEP 23

PARTS REQUIRED

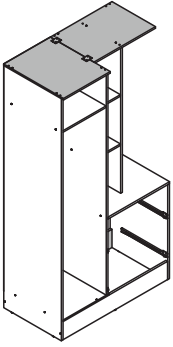

HARDWARE REQUIRED

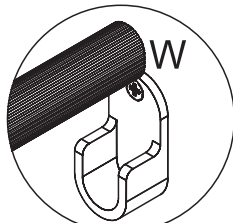

Detail 19

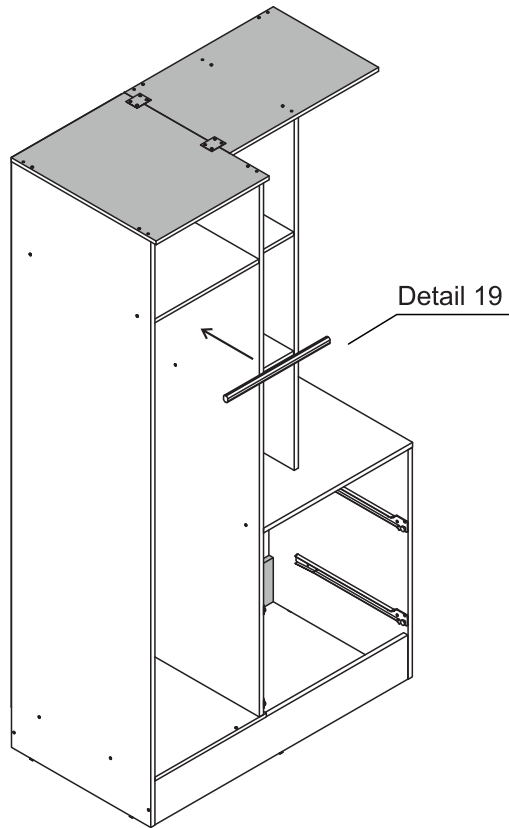

STEP 24

PARTS REQUIRED

17 - DRAWER FRONT	x2
-------------------	----

18 - DRAWER SIDE	x4
------------------	----

19 - DRAWER BACK PANEL	x2
------------------------	----

HARDWARE REQUIRED

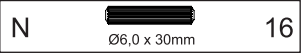

TOOLS REQUIRED

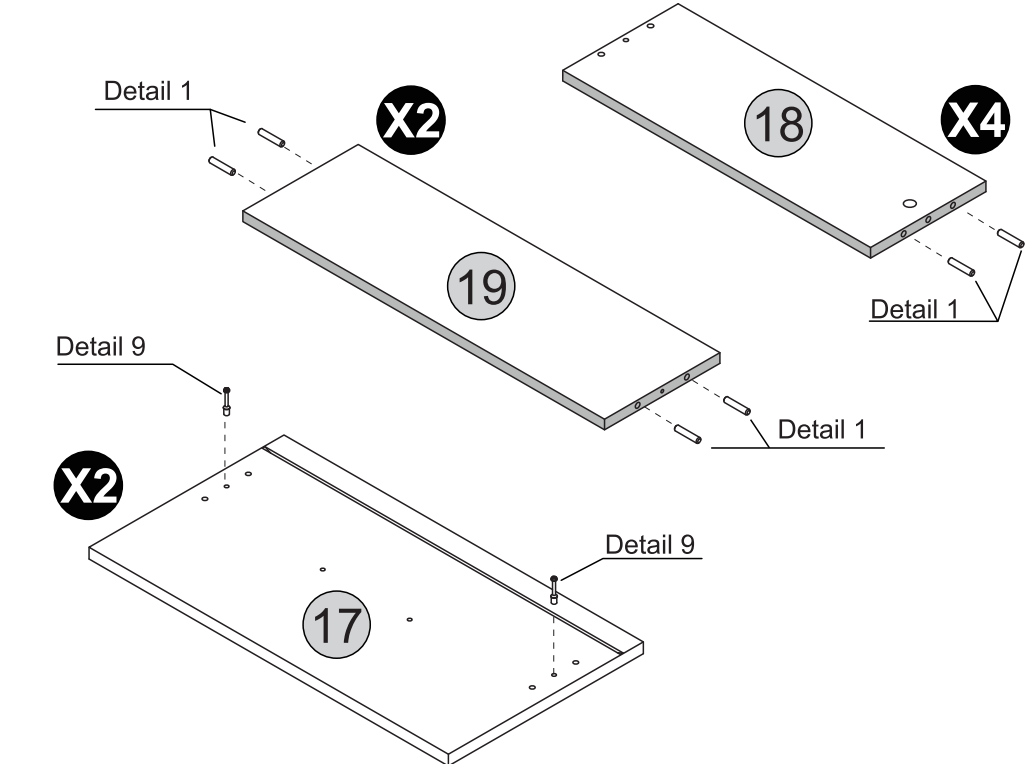

Detail 1

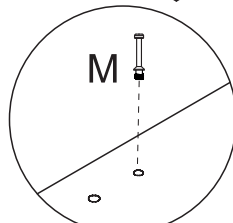

Detail 9

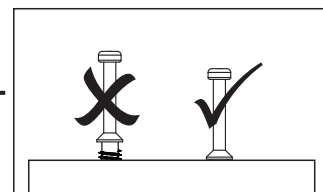

STEP 25

PARTS REQUIRED

18 - DRAWER SIDE x4

19 - DRAWER BACK PANEL x2

HARDWARE REQUIRED

B  04
Ø3,5 x 40mm

H  01

TOOLS REQUIRED

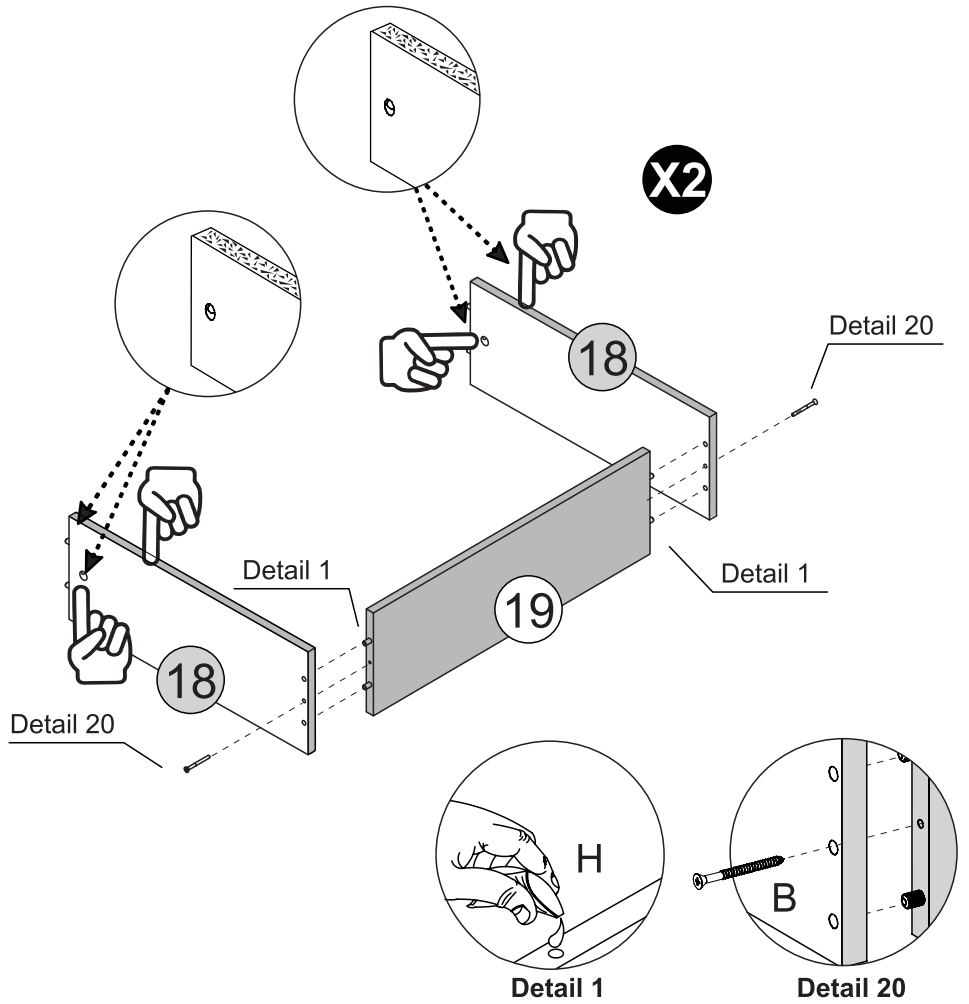
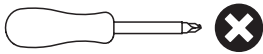

STEP 26

PARTS REQUIRED

17 - DRAWER FRONT x2

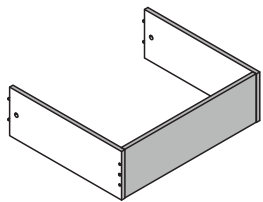

HARDWARE REQUIRED

H  01

TOOLS REQUIRED

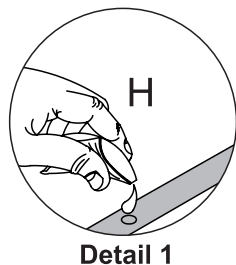
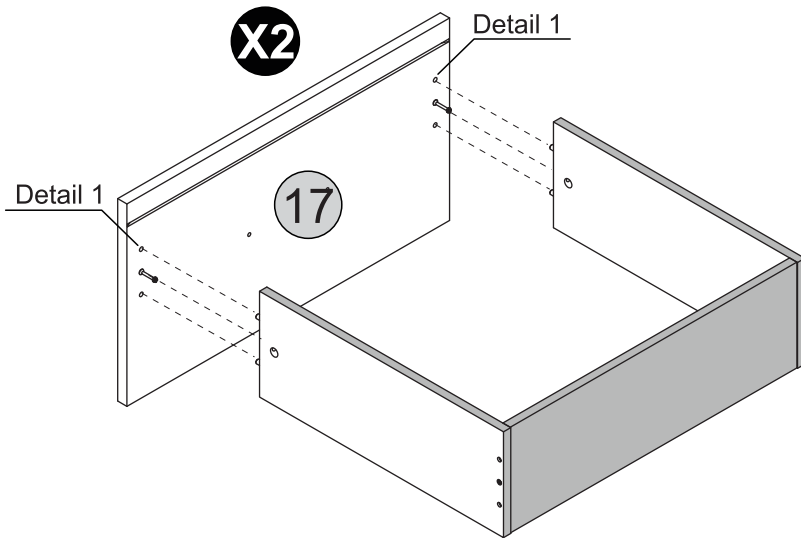

STEP 27

PARTS REQUIRED

17 - DRAWER FRONT x2

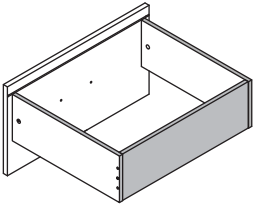

HARDWARE REQUIRED

L  04

U  08

TOOLS REQUIRED

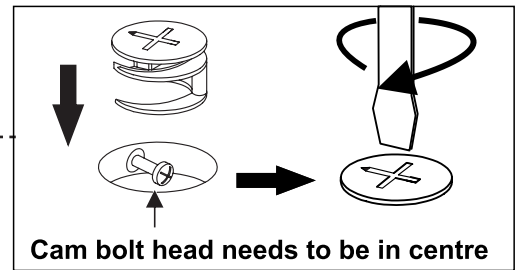
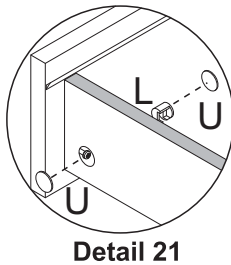
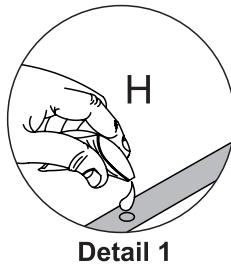
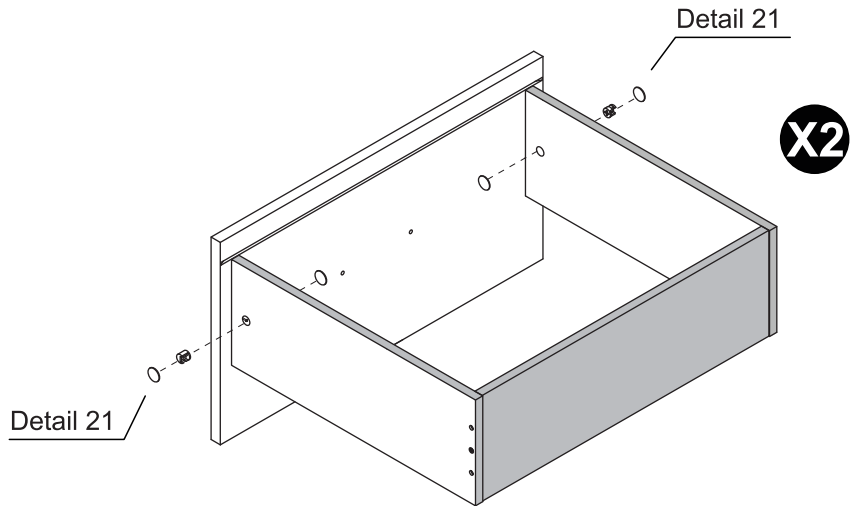
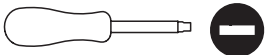

STEP 28

PARTS REQUIRED

20 - DRAWER BOTTOM x2

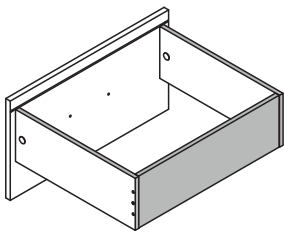

HARDWARE REQUIRED

T  10 x 10 08

TOOLS REQUIRED

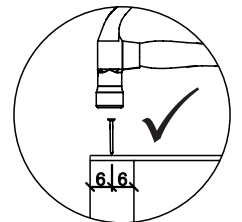
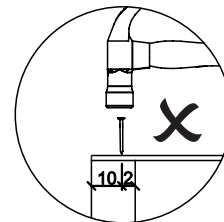
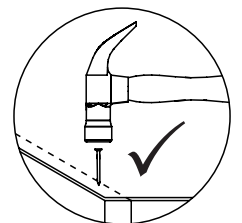
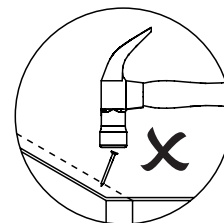
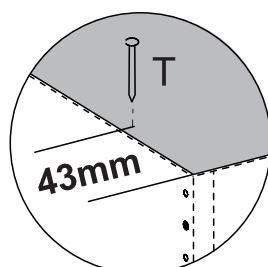
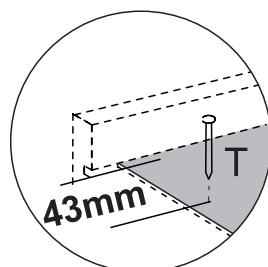
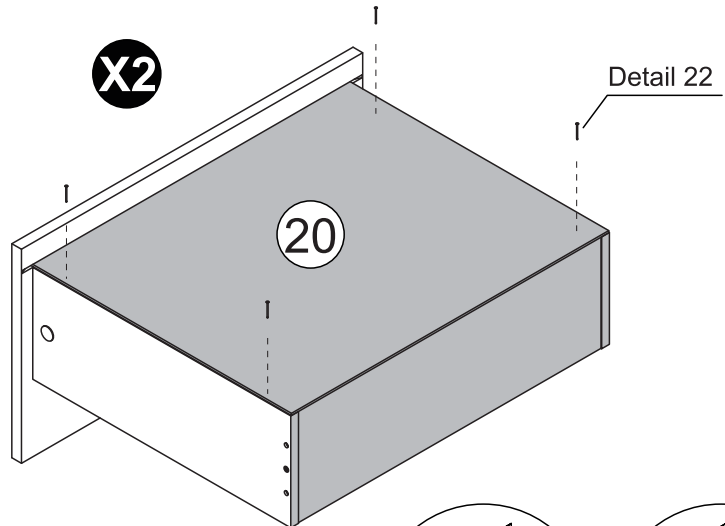
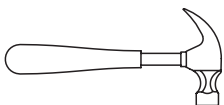

STEP 29

PARTS REQUIRED

20 - DRAWER BOTTOM x2

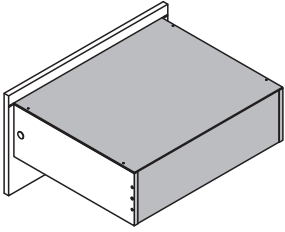

HARDWARE REQUIRED

T 10 x 10 10

TOOLS REQUIRED

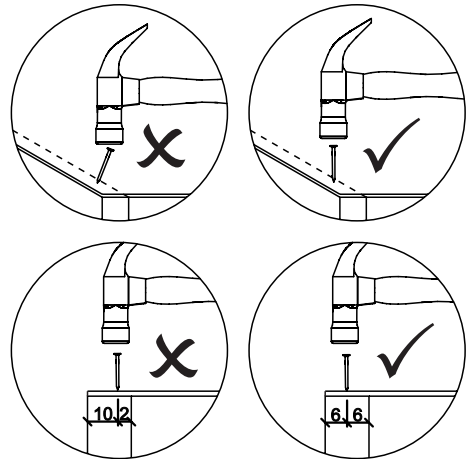
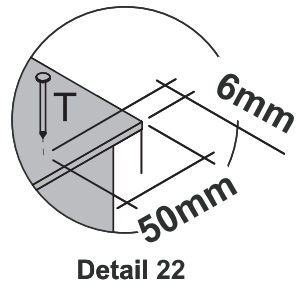
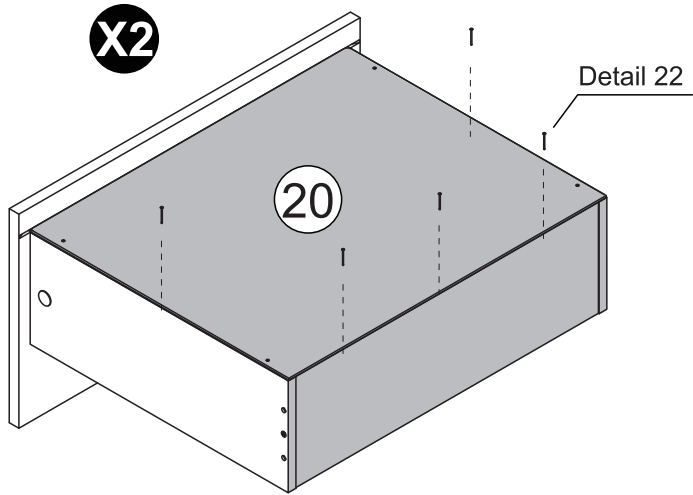
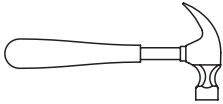

STEP 30

PARTS REQUIRED

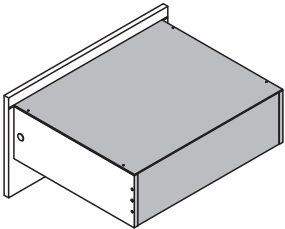

HARDWARE REQUIRED

D \oplus Ø4,0 x 14mm 08

I LEFT 02

I RIGHT 02

TOOLS REQUIRED

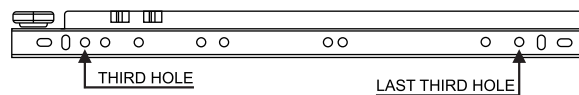
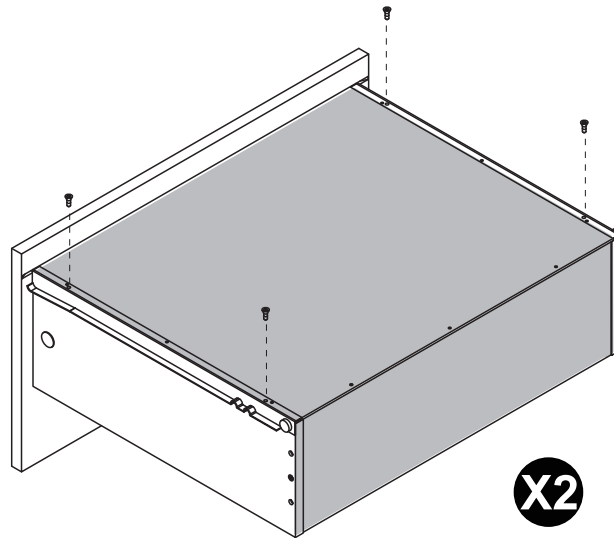
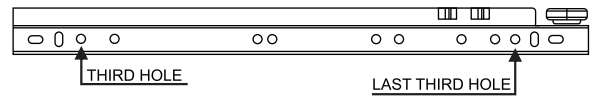
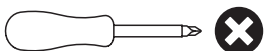

STEP 31

PARTS REQUIRED

16 - DOOR x1

HARDWARE REQUIRED

D  06
Ø4,0 x 14mm

K  03

TOOLS REQUIRED

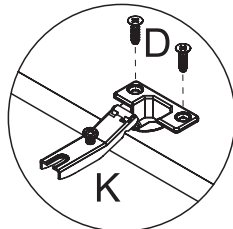
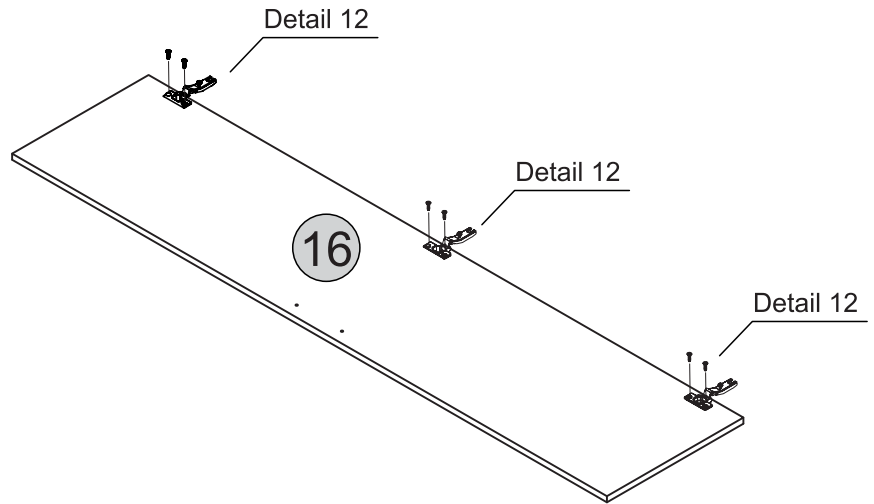
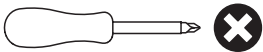

Detail 12

STEP 32

PARTS REQUIRED

16 - DOOR x1

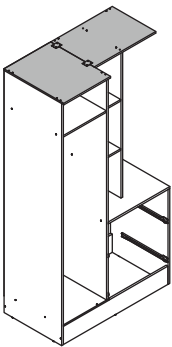

HARDWARE REQUIRED

U  22

TOOLS REQUIRED

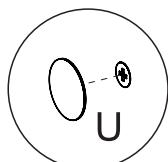
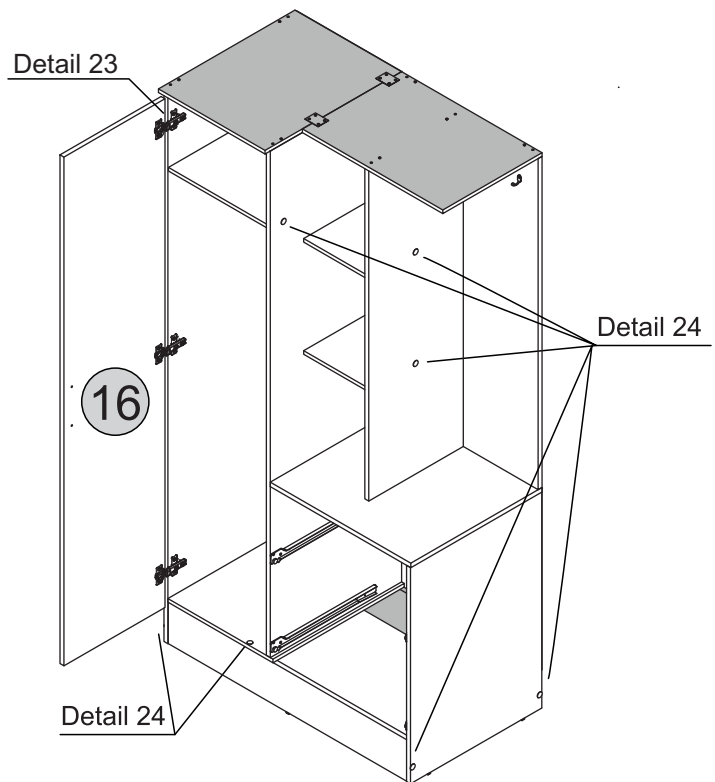
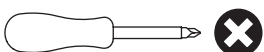

Detail 24

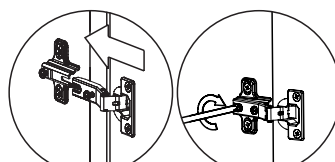

Detail 23

STEP 33

PARTS REQUIRED

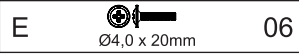
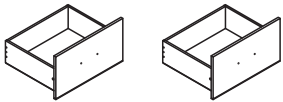
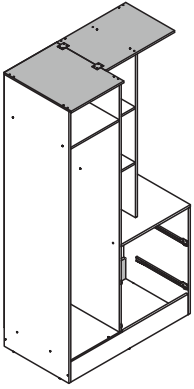

TOOLS REQUIRED

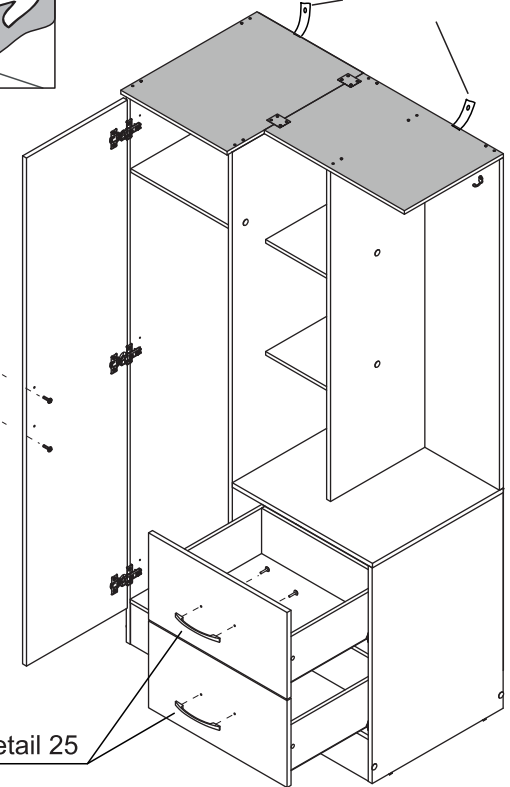
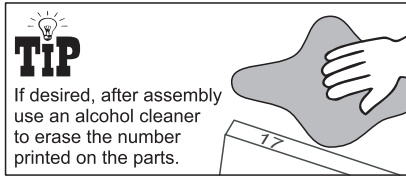
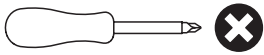

Detail 25

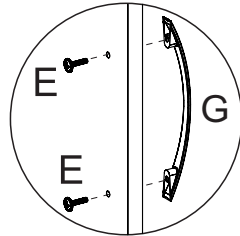

Detail 25

STEP 34

PARTS REQUIRED

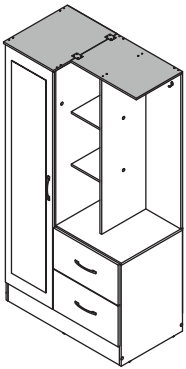

HARDWARE REQUIRED

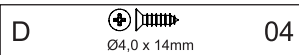

TOOLS REQUIRED

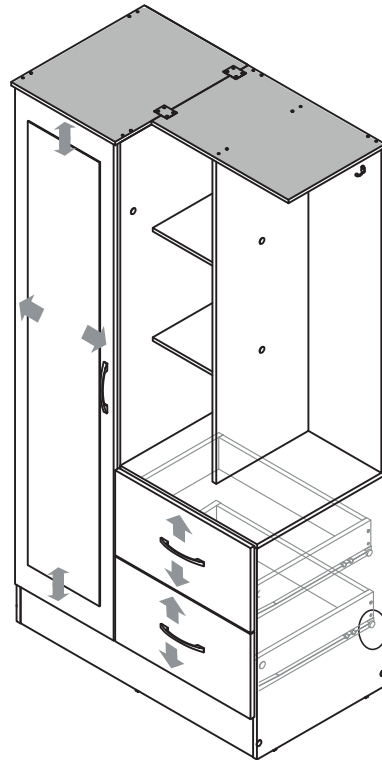
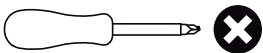

Detail 23

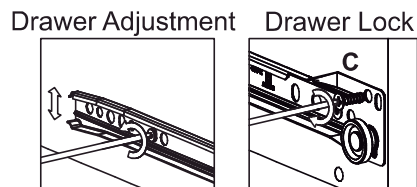

Detail 23

Height Adjustment

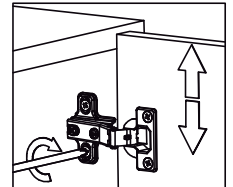

Internal Adjustment

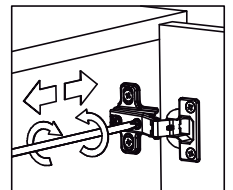

Depth Adjustment

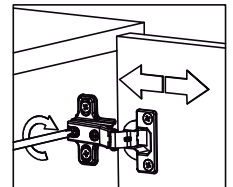
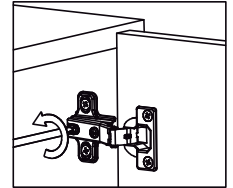

WARNING

Serious or fatal injuries can occur from furniture tipping over. To prevent the furniture from tipping over we recommend that it is permanently fixed to the wall.

Wall fixings are not supplied with this product as different wall materials require different types of fixing devices. Please make sure you use fixings suitable for the walls in your home.

