

Carefully unpack all parts and identify them with parts list before attempting to assemble.

IMPORTANT: DO NOT TIGHTEN BOLTS AND SCREWS UNTIL YOU HAVE COMPLETED ASSEMBLY.

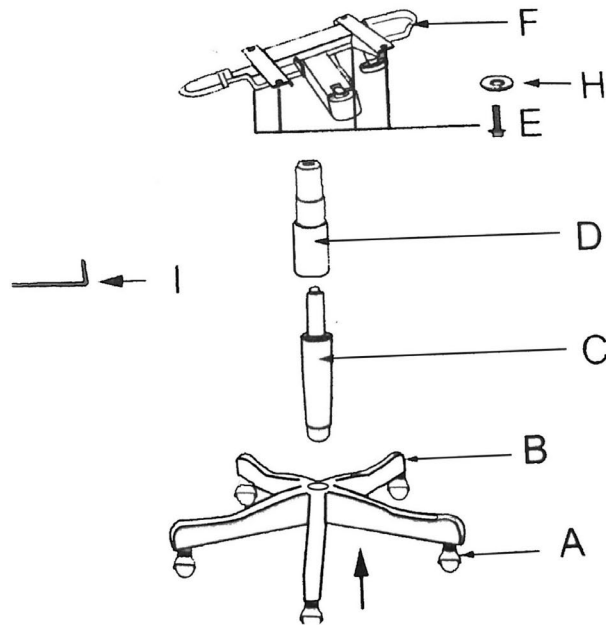

1. Put 5 CASTERS (A) into the holes of 5 STAR BASE (B).
2. Insert GAS LIFT (C) to the center hole top of 5 STAR BASE (B).
3. Insert BELLOW (D) over GAS LIFT (C).
4. Attach SEAT PLATE (F) to the pre-assembled seat (G) by using 4 FLATWASHERS(H) 4 SCREWS (E).
5. Insert the pre-assembled seat unit onto the gas lift to finish the assembly.



Parts List

A. CASTERS	5
B. 5 STAR BASE	1
C. GAS LIFT	1
D. BELLOW	1
E. SCREWS (M8×25MM)	4
F. SEAT PLATE	1
G. THE PRE-ASSEMBLED SEAT	1
H. FLATWASHERS(22MM×8MM×1.5MMT)	4
I. ALLEN KEY	1