

Assembly Instructions

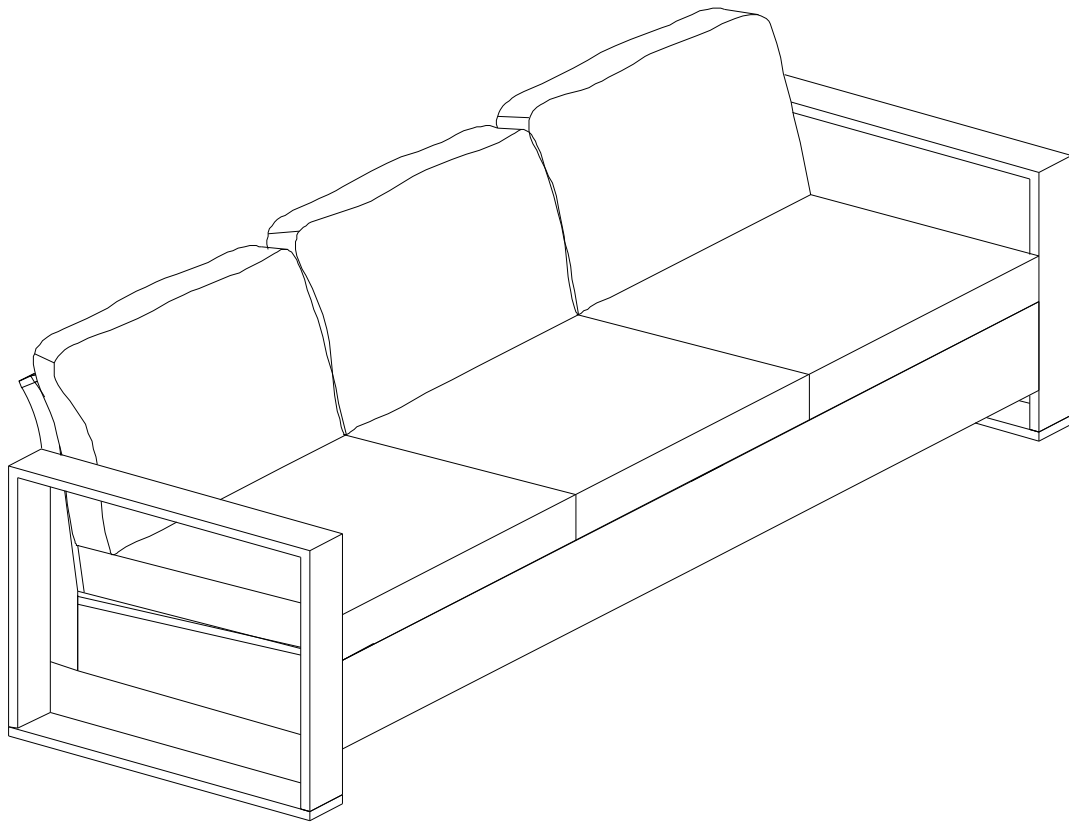







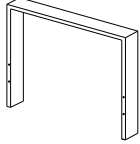
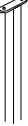
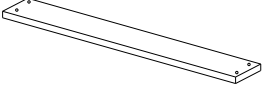
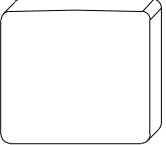
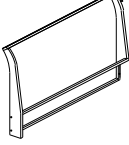
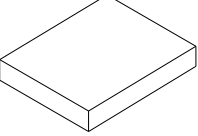
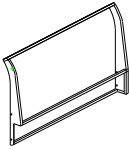

For any missing hardware, damaged parts and other problems.
WELCOME to email us at: service@behousewell.com

Or call at 1-888-733-8169 Toll free
Between 9AM and 5PM Eastern time, Monday through Friday

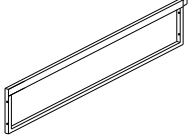
***Don't fully tighten all the bolts till the very end!**

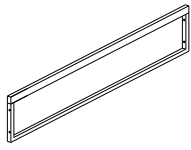

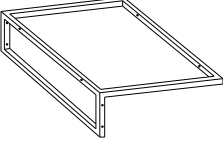
PRE-ASSEMBLY PREPARATION:

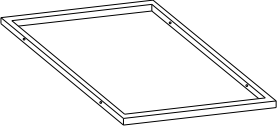
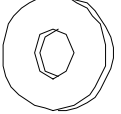
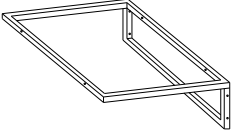
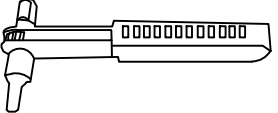
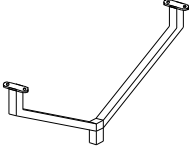
- Please read through the instructions before beginning assembly.
- Clear out the space for assembly and lay out all of the parts based on the Parts List, extra room will allow you to easily determine if all the pieces are present.
- Keep small parts and pieces away from children until fully assembled.

Part no.	Part	QTY	Image	Part no.	Part	QTY	Image
A	arm	2		K	Middle foot	1	
B	foot	2		L	Back cushion	3	
C	Right back panel	1		M	Seat cushion	3	
D	Left back panel	1		N	Bolt (M6*30mm)	8	
E	Left front panel	1		O	Bolt (M6*35mm)	21	
F	Right front panel	1		P	Bolt (M6*40mm)	12	
G	Right seat panel	1		Q	Bolt (M6*20mm)	6	
H	Middle Seat panel	1		R	Washer M6	47	
I	Left seat panel	1		S	Ratchet wrench	1	
J	Middle foot	1					

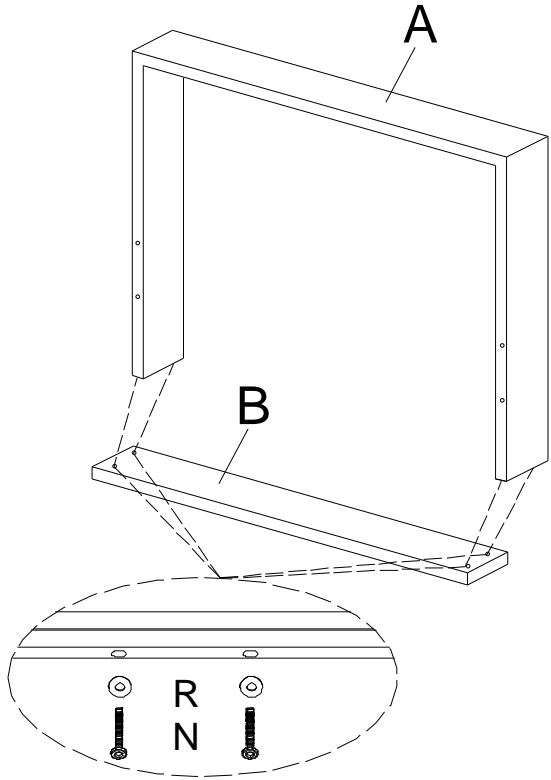
Step 1: Attach foot B to arm A with 4pcs bolts N and 4pcs washers R, using Ratchet wrench S. Repeat it to assemble the second arm and foot .



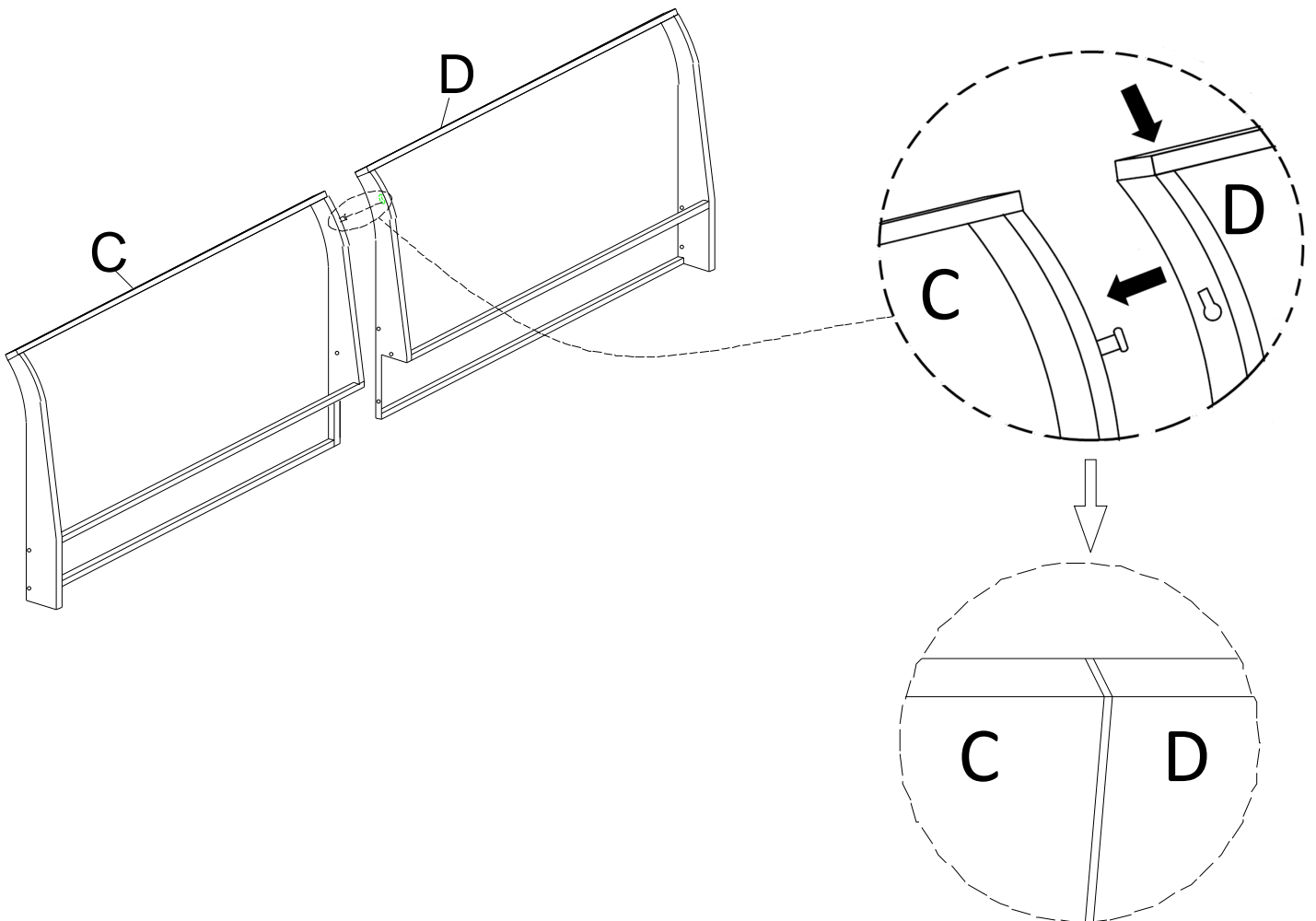

N		M6*30	8
R		Ø16*Ø6.5*1	8

Step 2: Attach back D to back C, and press back D down to keep C&D on the same level.



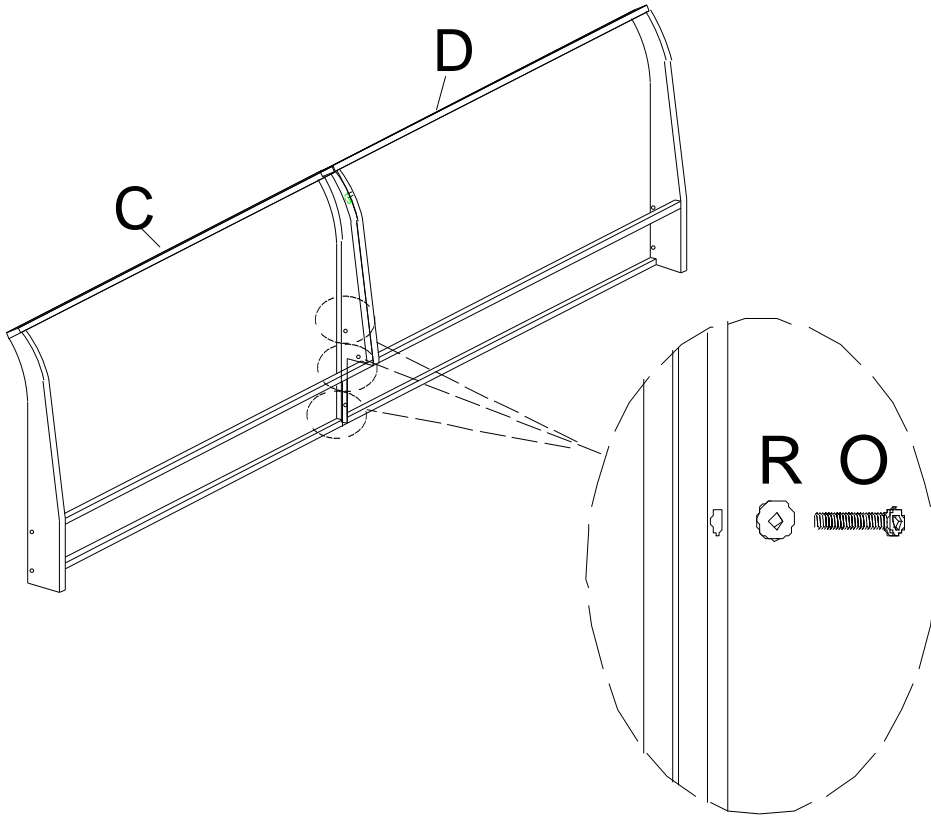

Step 3: Attach back C & D with 3pcs bolts O and 3pcs washers R, using Ratchet wrench S. Note: Don't fully tighten the bolts.



O		M6*35	3
R		Ø16*Ø6.5*1	3

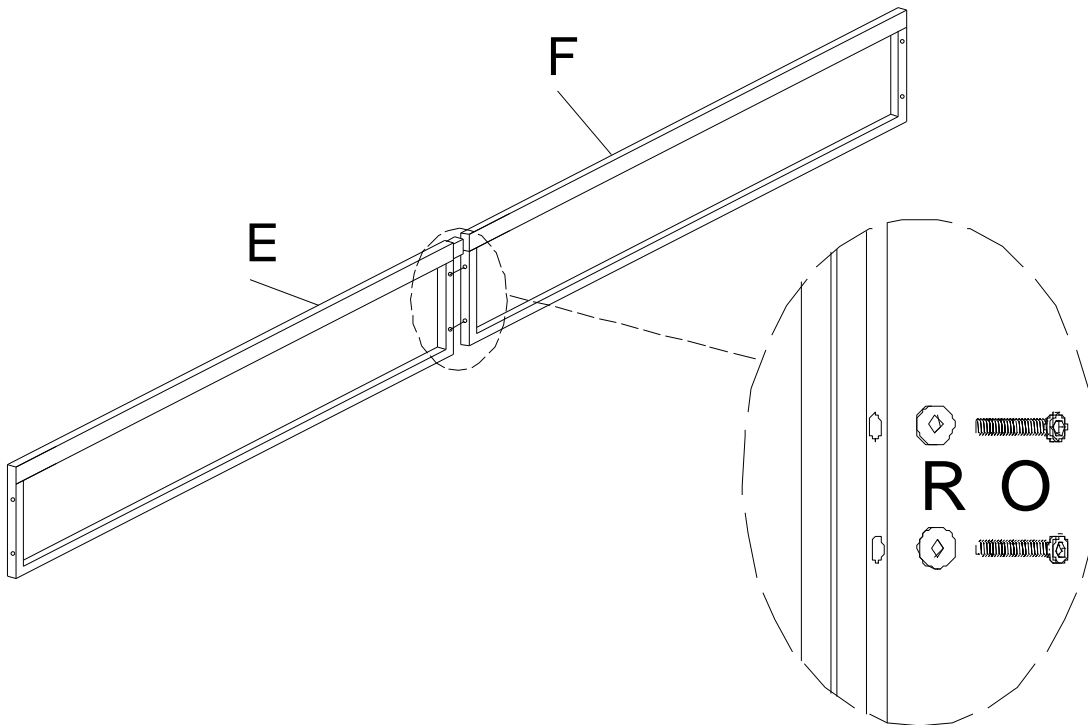

Step 4: Attach front panel E & F with 2pcs bolts O and 2pcs washers R, using Ratchet wrench S. Note: Don't fully tighten the bolts.



O		M6*35	2
R		Ø16*Ø6.5*1	2

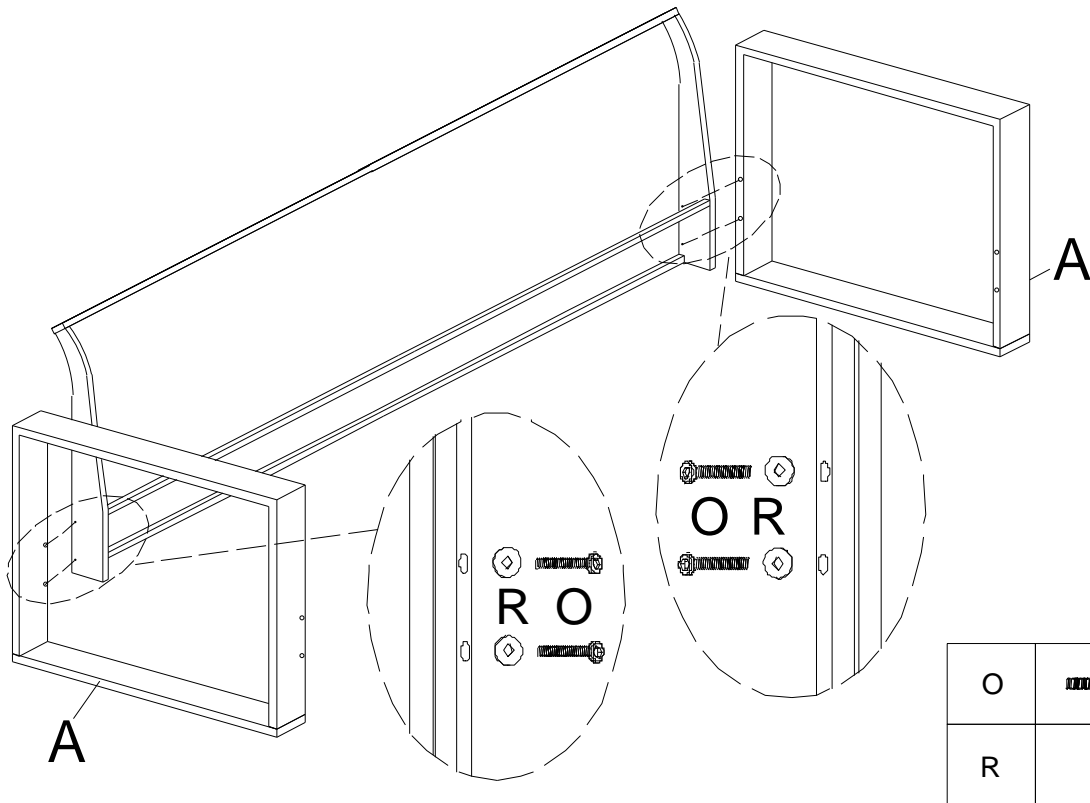

Step 5: Attach arms A to backs with 4pcs bolts O and 4pcs washers R, using Ratchet wrench S. Note: Don't fully tighten the bolts.

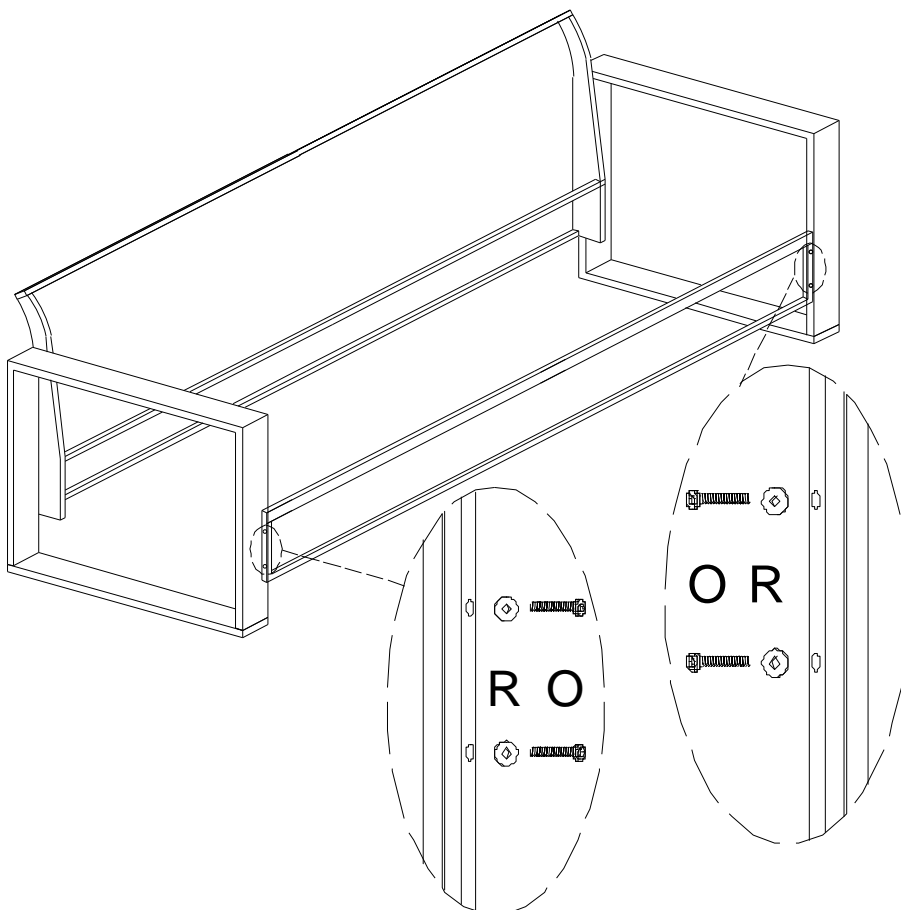

O		M6*35	4
R		Ø16*Ø6.5*1	4

Step 6: Attach front panels to arms with 4pcs bolts O and 4pcs washers R, using Ratchet wrench S. Note: Don't fully tighten the bolts.



O		M6*35	4
R		Ø16*Ø6.5*1	4

Step 7: Attach seat panels I & H & G to front panels with 4pcs bolts O, 6pcs bolts P and 10pcs washers R, using Ratchet wrench S.
 Note: Don't fully tighten the bolts.

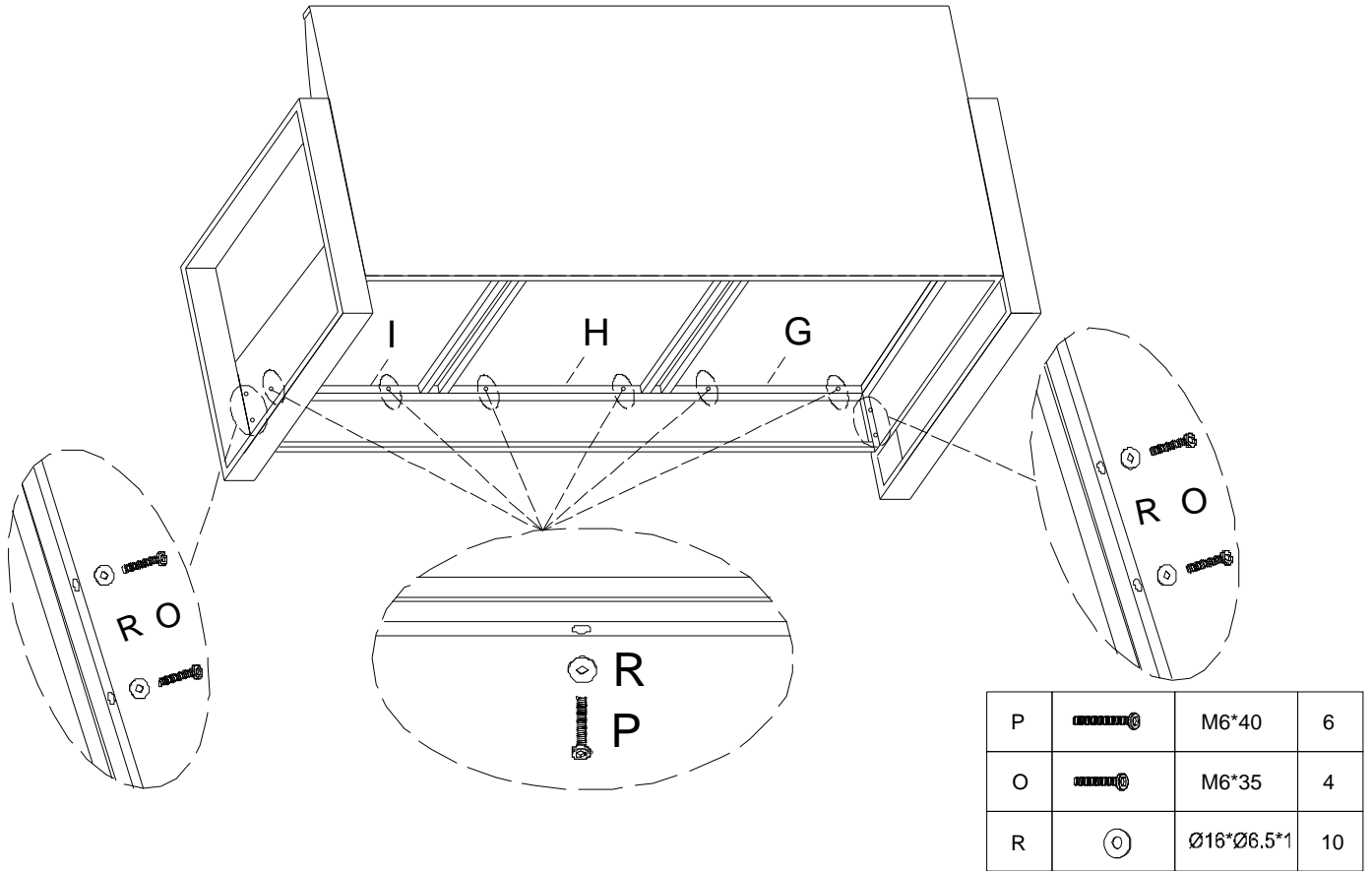

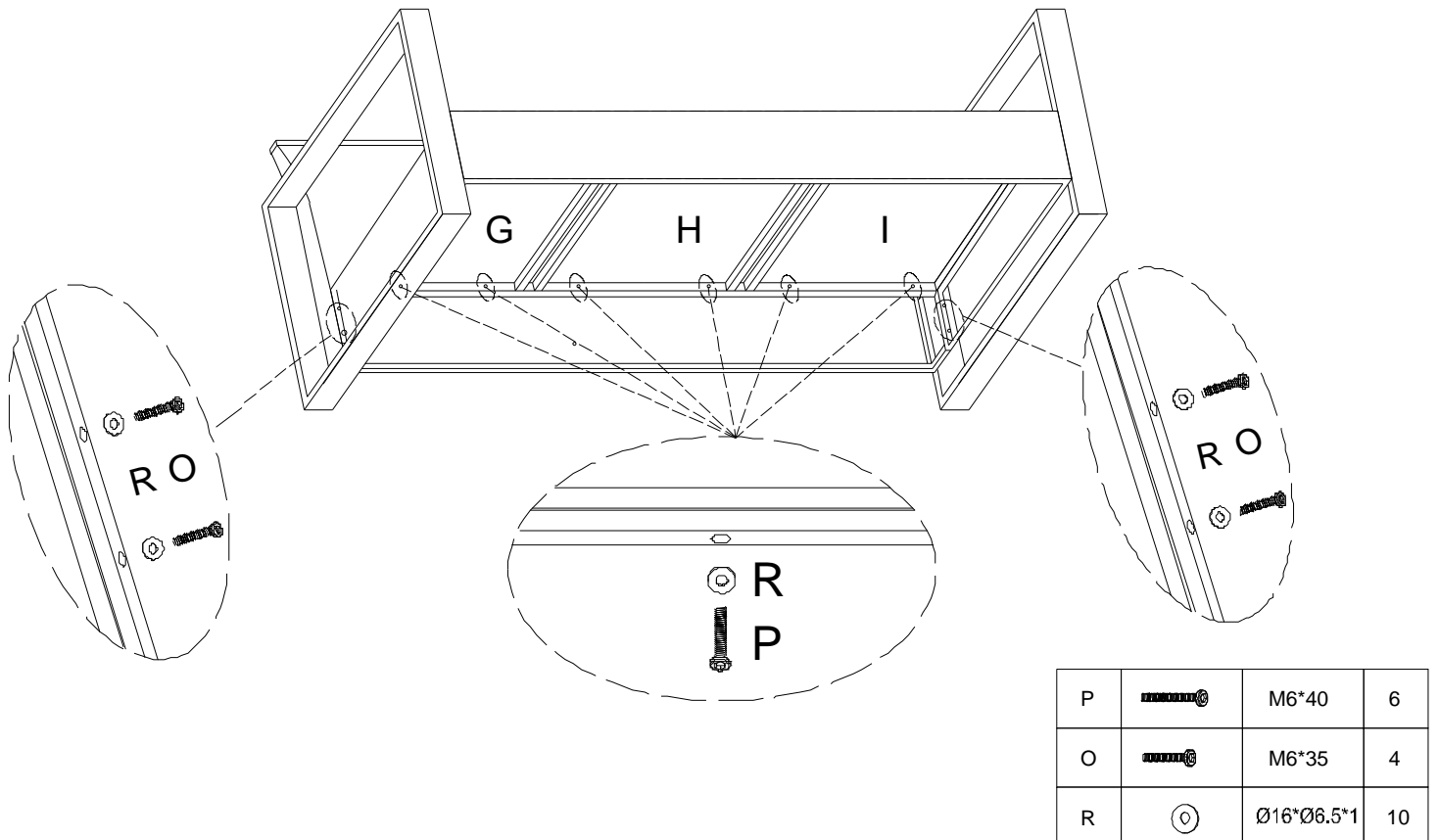

Step 8: Attach seat panels I & H & G to back panels C&D with 4pcs bolts O, 6pcs bolts P and 10pcs washers R, using Ratchet wrench S.
 Note: Don't fully tighten the bolts.

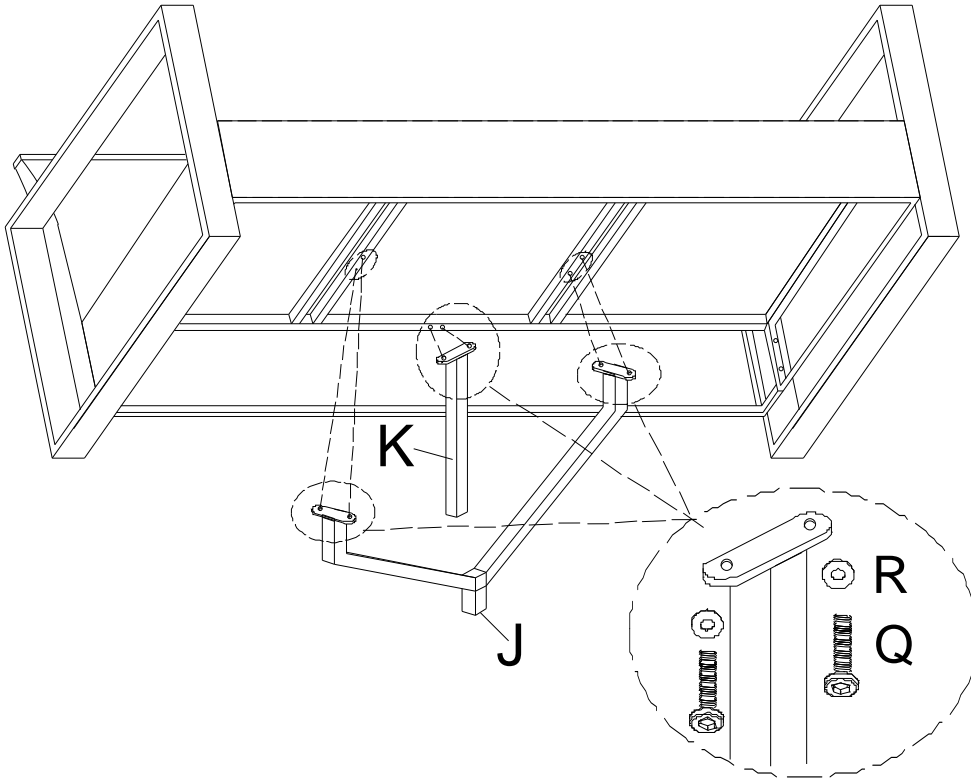

Step 9: Attach middle foot J&K to seat with 6pcs bolts Q and 6pcs washers R, using Ratchet wrench S. Note: Please fully tighten all the bolts.



Q		M6*20	6
R		Ø16*Ø6.5*1	6

Step 10: Put seat cushions M and back cushions L onto the seat .
Assembly is now complete and the product is ready for use.

