

# Tour Bureau / Desk storage unit

Instructions d'assemblage / Assembly instructions

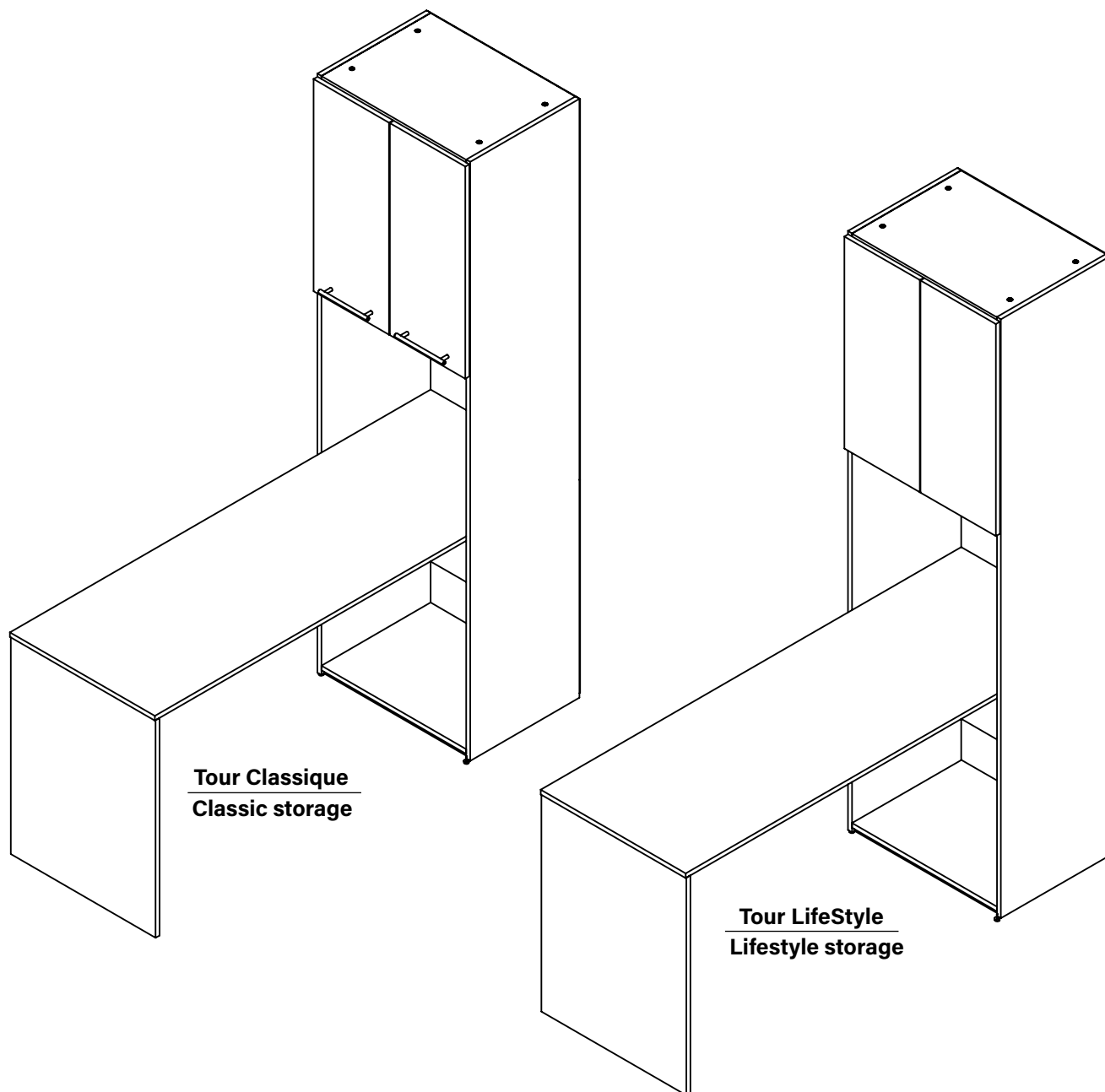

*\*Lien guide interactif page 2 / Link interactive guide page 2*



**Si le meuble ne fonctionne pas ou s'il manque une pièce, contactez:  
Ne contactez pas le magasin ou le revendeur.**

**If the furniture does not work or if a part is missing, contact:  
Do not contact the store or dealer.**

# Pièces / Parts

Guide interactif  
Interactive guide

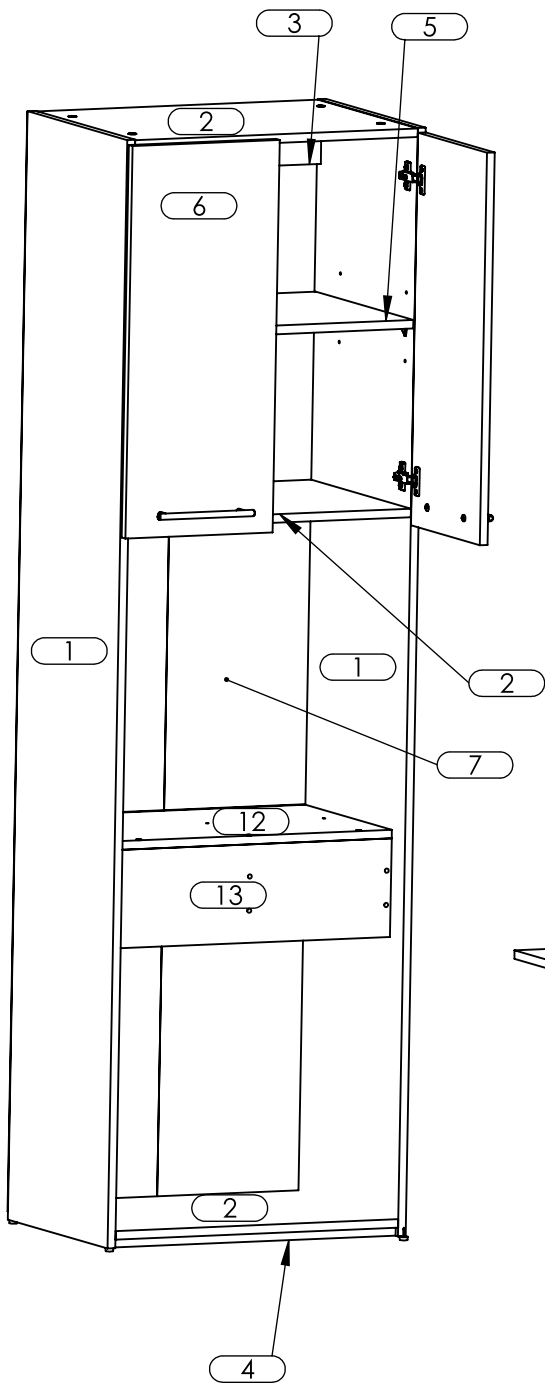

#	PIECE/PART	DESCRIPTION	QTE
1	CO-TOB-8118	Côté tour/Side unit	2
2	TA-FX-2418	Tablette fixe/Fixe shelf	3
3	TR-H-24XX	Traverse haute/Top rail	1
4	TR-B-24XX	Traverse basse/Lower rail	2
5	TA-AJ-24XX	Tablette ajustable/Adjustable shelf	1
6	PO-HO-2481	Porte/Door	2
7	DOK-2481	Dos/Back	2
9	BU-DE-2466	Dessus bureau/Desk top	1
10	BU-CO-24XX	Côté bureau/Desk side	1
11	BU-TR-XX66	Traverse bureau/Desk rail	1
12	TA-BU-2418	Tablette bureau/Desk shelf	1
13	BU-FO-24XX	Fond bureau/Desk background	1

**? POUR TOUTE QUESTION /  
FOR ANY QUESTION**

 [support@evolutek.ca](mailto:support@evolutek.ca)

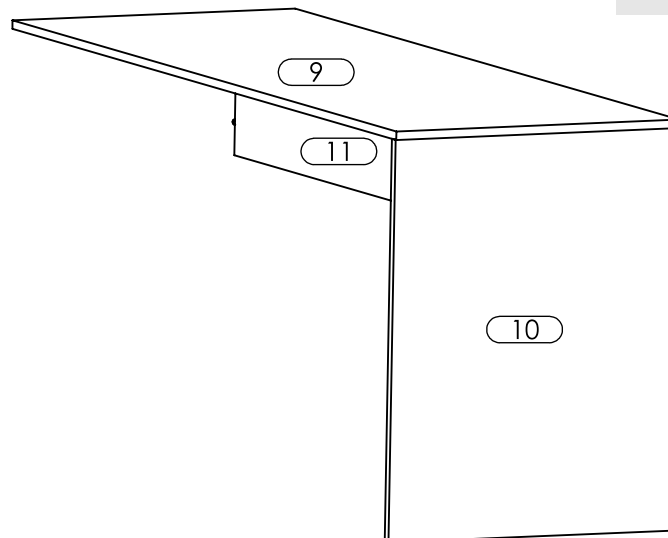





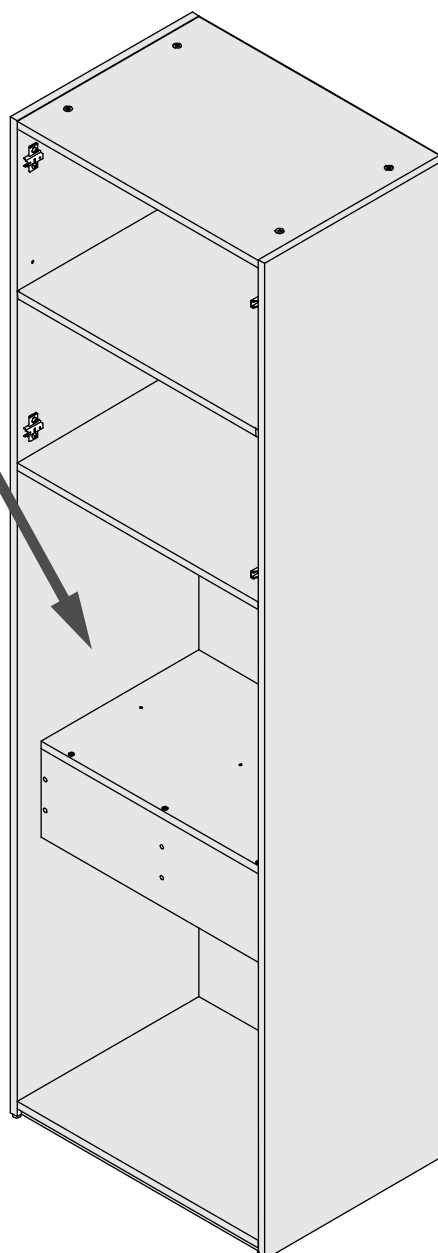





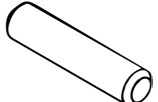

Votre caisson est déjà assemblé?  
**Passez à l'étape 8 !**

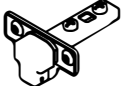



Your storage cabinet is already assembled?  
**Skip to step 8 !**

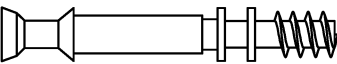
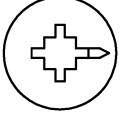

## Liste de contrôle de la quincaillerie / Hardware checklist

PIÈCE/PART	QTÉ/QTY	PIÈCE/PART	QTÉ/QTY	PIÈCE/PART	QTÉ/QTY
					
CAM-B-10	30	CAM-D-10X35MM	30	GOU-B-516X118	6
					
VIS-W-8X1	9	VIS-P-6X58	8	PAT-CL-5	6
					
PEN-PL-0MM	4	PEN-26MM	4	VIS-C-2	5
*Modèle classique seulement/Classic model only 		*Modèle classique seulement/ Classic model only 			
POI-RO-160MM	2	VIS-R-3X22MM	4	Support tablette Shelf support	4
					
Clou/Nail	26				

## Quincaillerie taille réelle / Full-size hardware

		
<i>VIS-C-2 VIS D'ASSEMBLAGE 2" ASSEMBLY SCREW</i>	<i>CAM-D-10X35MM DOUILLE DOWEL</i>	<i>CAM-B-10 CAME CAM</i>
		
<i>VIS-R-3X22MM VIS TÊTE RONDE M3X22mm ROUND HEAD SCREW</i>	<i>VIS-P-6X58 VIS TÊTE PLATE #6X5/8" FLATHEAD SCREW</i>	<i>VIS-W-8X1 VIS TÊTE RONDELLE #8X1" WASHER HEAD SCREW</i>

## Remarques particulières / Special remarks

### Outils requis / Required tools

-Marteau / Hammer

-Tournevis Robertson #1, 2, 3 et plat / Robertson screwdriver #1,2,3 and flathead

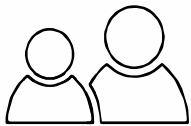

Deux personnes sont requises pour l'assemblage de ce meuble.  
Two people required to assemble this unit.

### Assemblage par came et goujon / Cam and dowel assembly

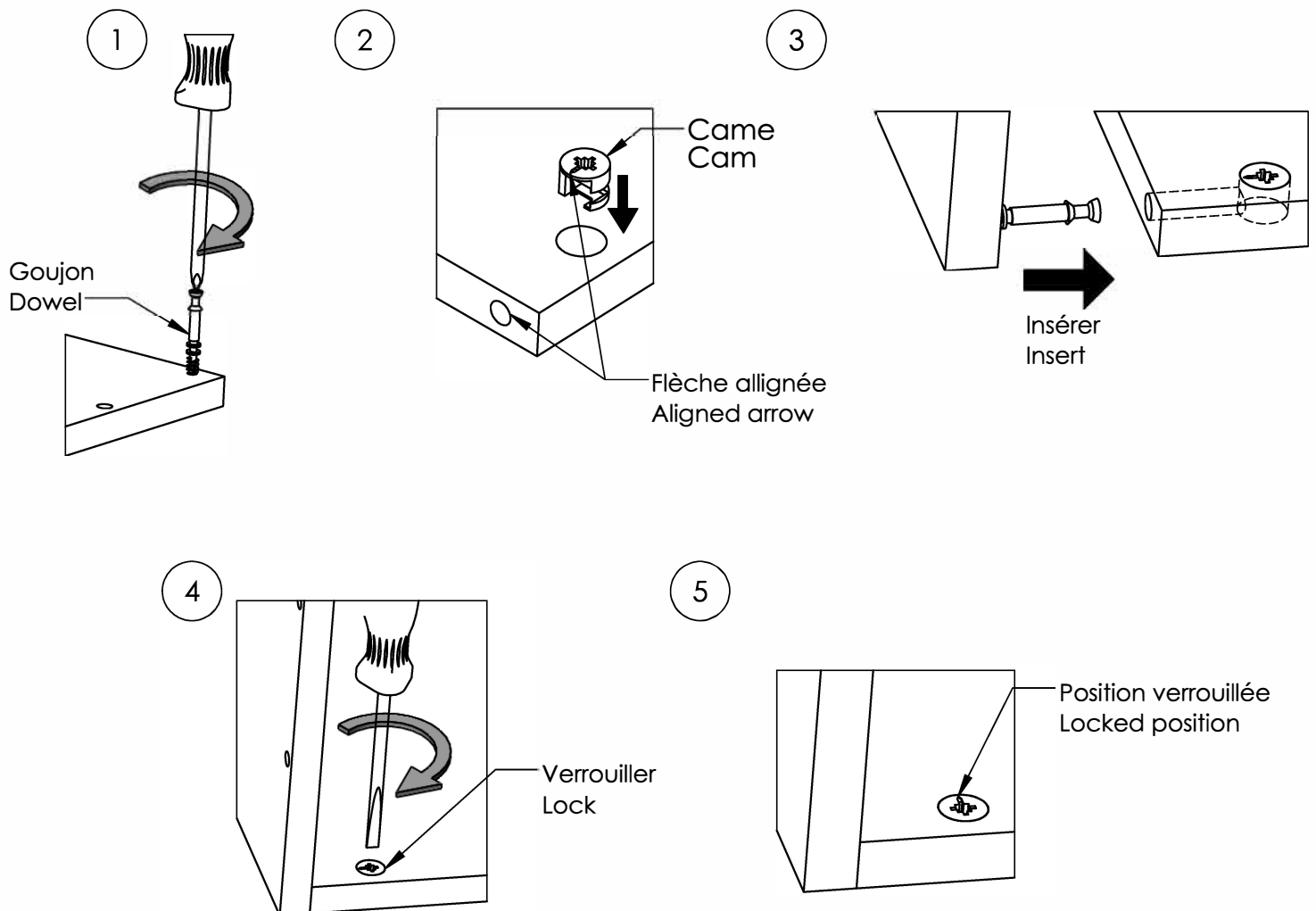

## 1- Installation des plaques de pentures / Installing hinge plates

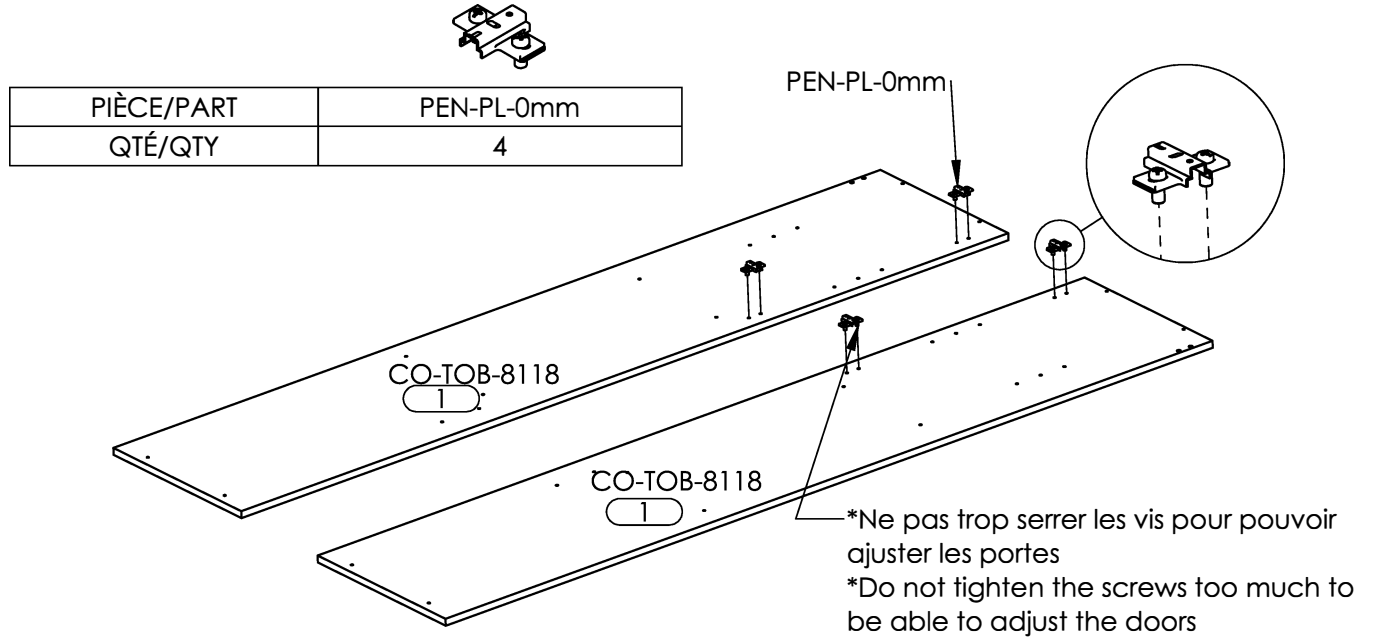

## 2- Installation des douilles / Installing sockets

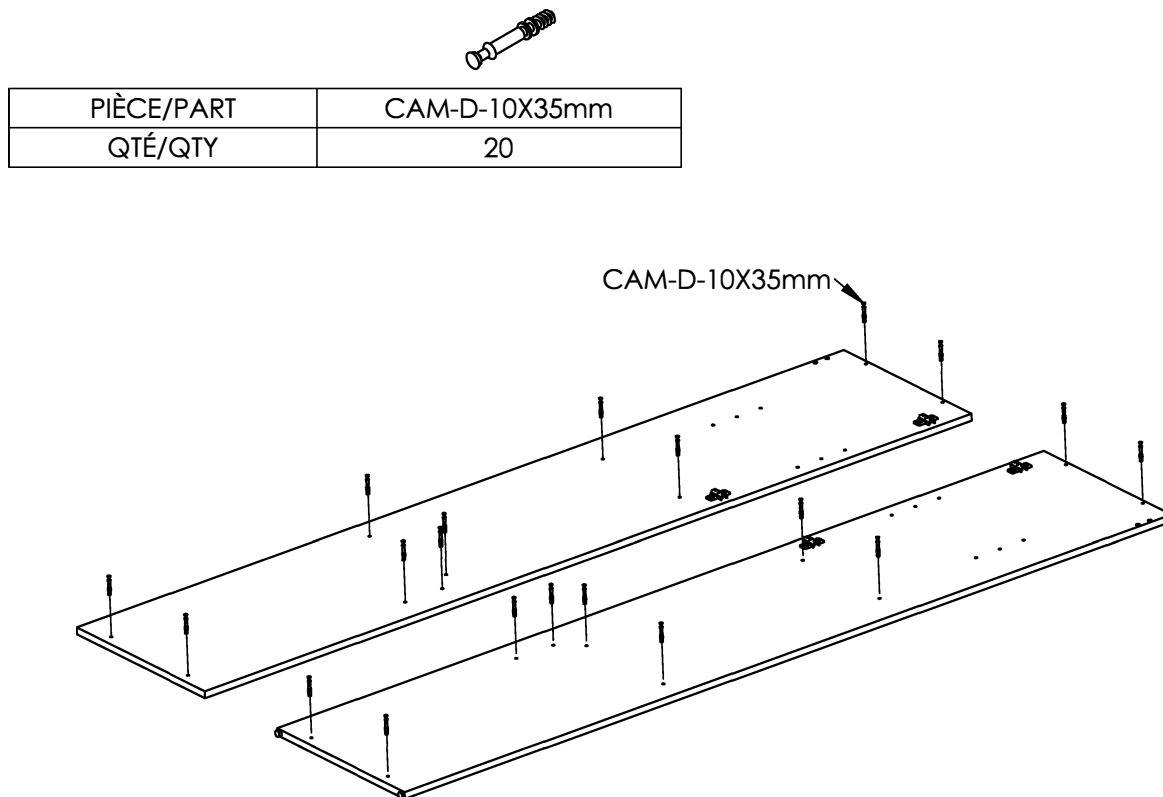

### 3- Installation des goujons / Installing dowels



PIÈCE/PART	GOU-B-516X118
QTÉ/QTY	4

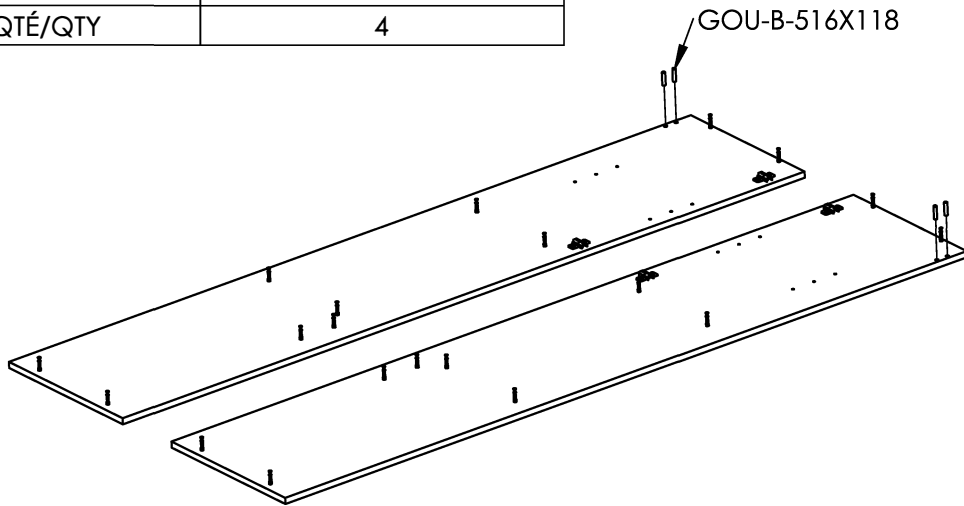

### 4- Assemblage de la tour / Assembling the unit



PIÈCE/PART	CAM-B-10
QTÉ/QTY	10

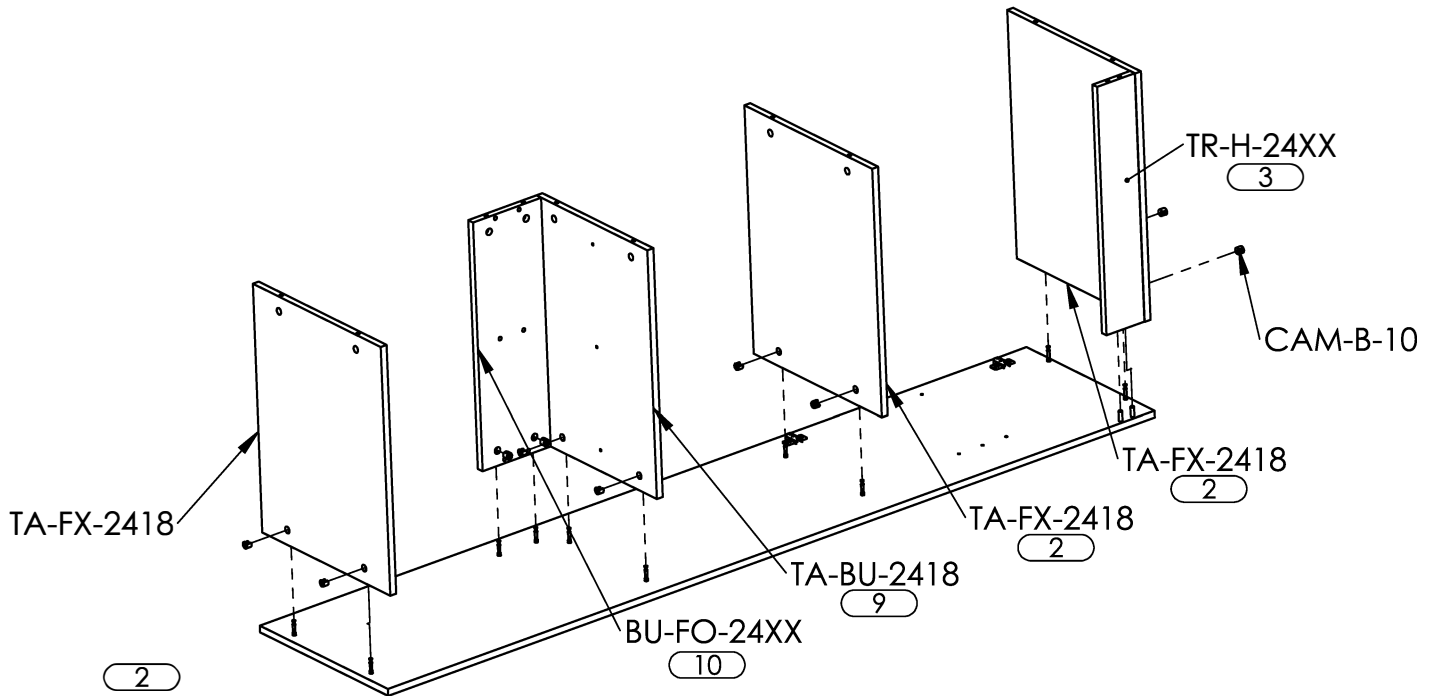

## 5- Assemblage de la tour / Assembling the unit



PIÈCE/PART	CAM-B-10
QTÉ/QTY	10

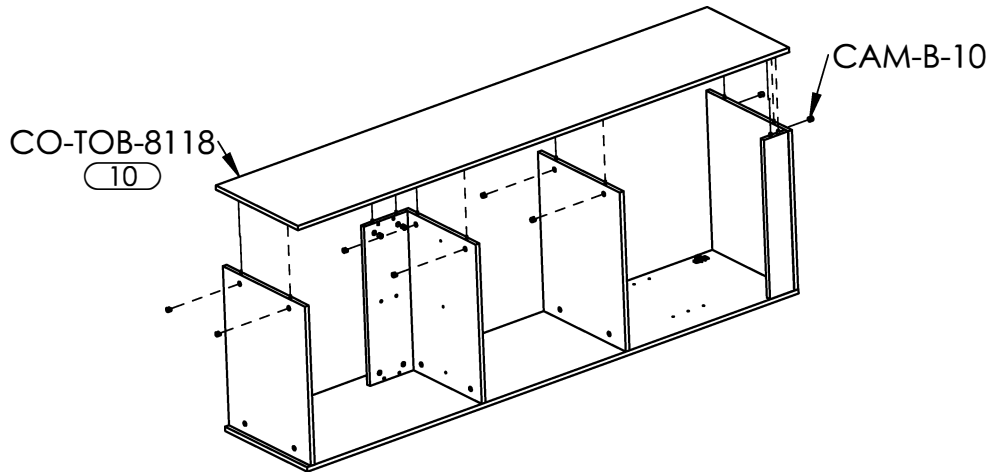

## 6- Assemblage de la tour / Assembling the unit



PIÈCE/PART	VIS-W-8X1	PAT-CL-58
QTÉ/QTY	6	4

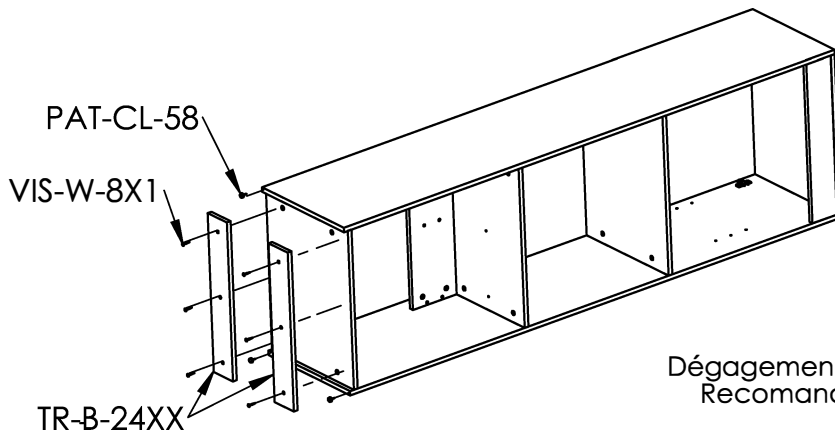

Dégagement recommandé: 10mm  
Recommended clearance: 3/8"

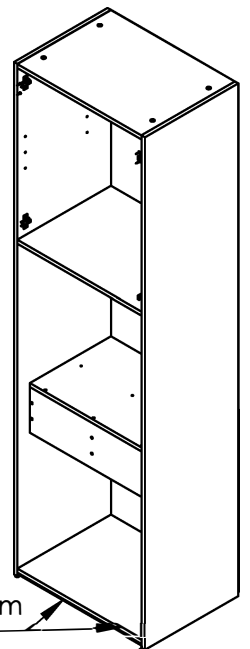

## 7- Assemblage de la tour / Assembling the unit



PIÈCE/PART	VIS-C-2
QTÉ/QTY	3

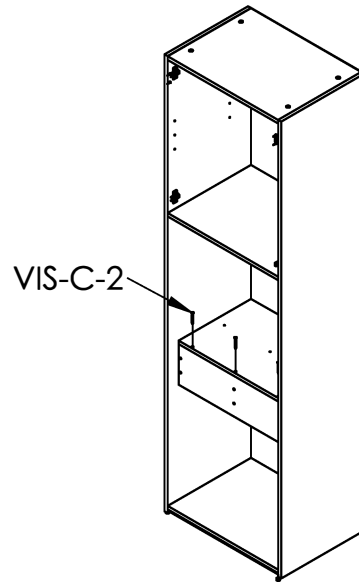

## 8- Installation de la tablette ajustable / Installing adjustable shelf



PIÈCE/PART	Support tablette / Shelf support
QTÉ/QTY	4

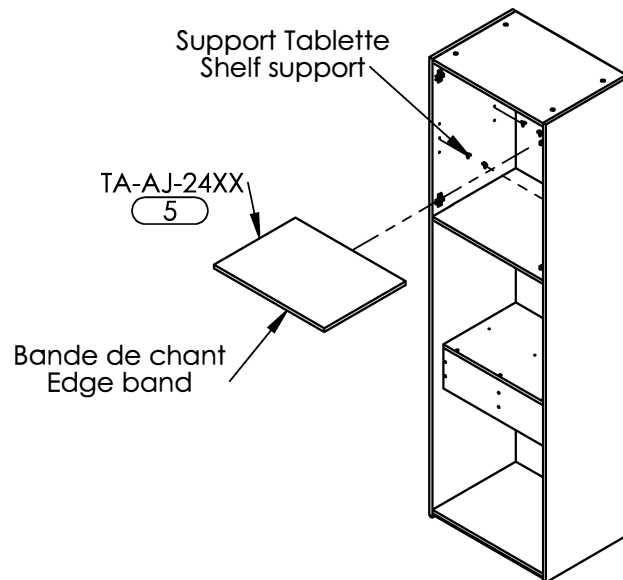

## 9- Installation des pentures / Installing hinges



PIÈCE/PART	VIS-P-6X58	PEN-26MM
QTÉ/QTY	8	4

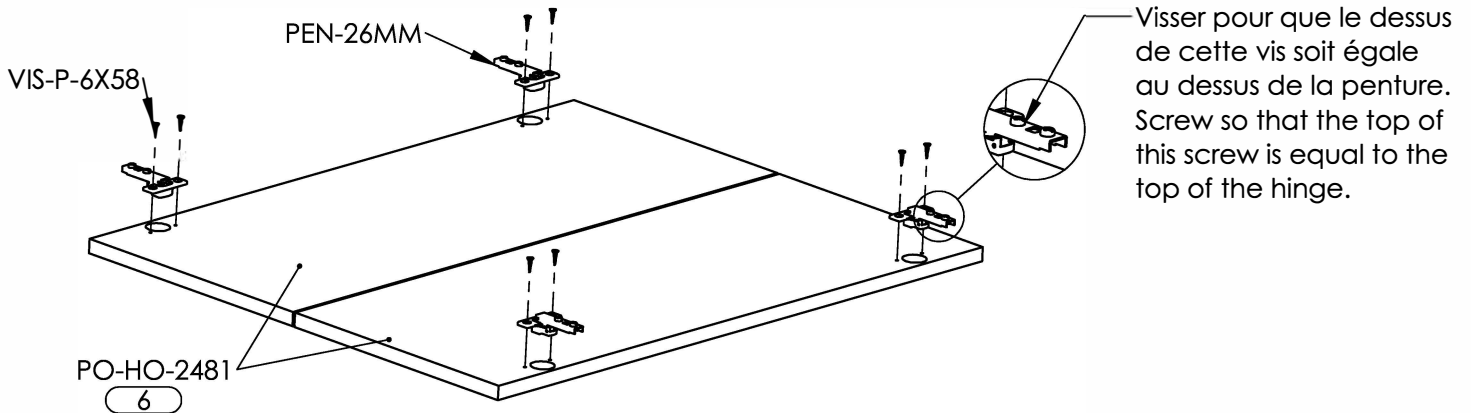

## 10- Installation des portes / Installing doors

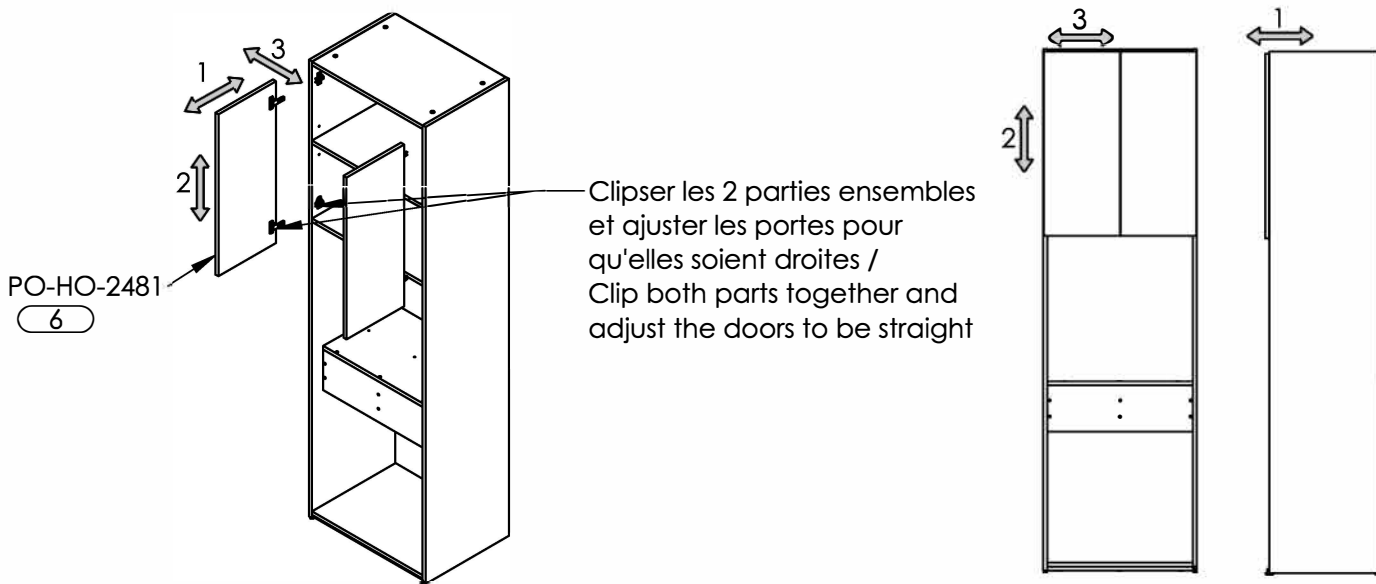

### Ajustement / Adjustment

Visser ou dévisser la vis fera bouger la porte dans la direction indiquée. / Screwing or unscrewing the screw will move the door in the indicated direction

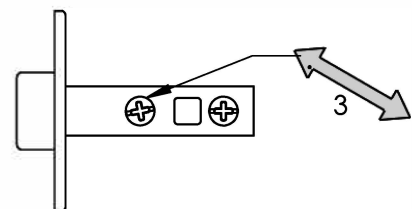
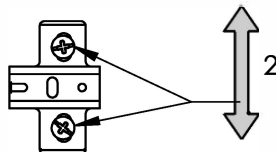
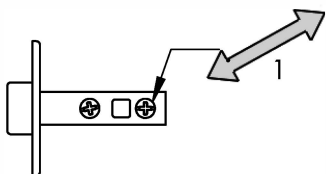

## 11- Installation des poignées ( \*Modèle classique seulement) Installing handles ( \*Classic model only)

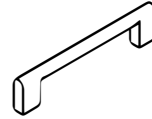

PIÈCE/PART	VIS-R-3X22MM	POI-RO-160MM
QTÉ/QTY	4	2

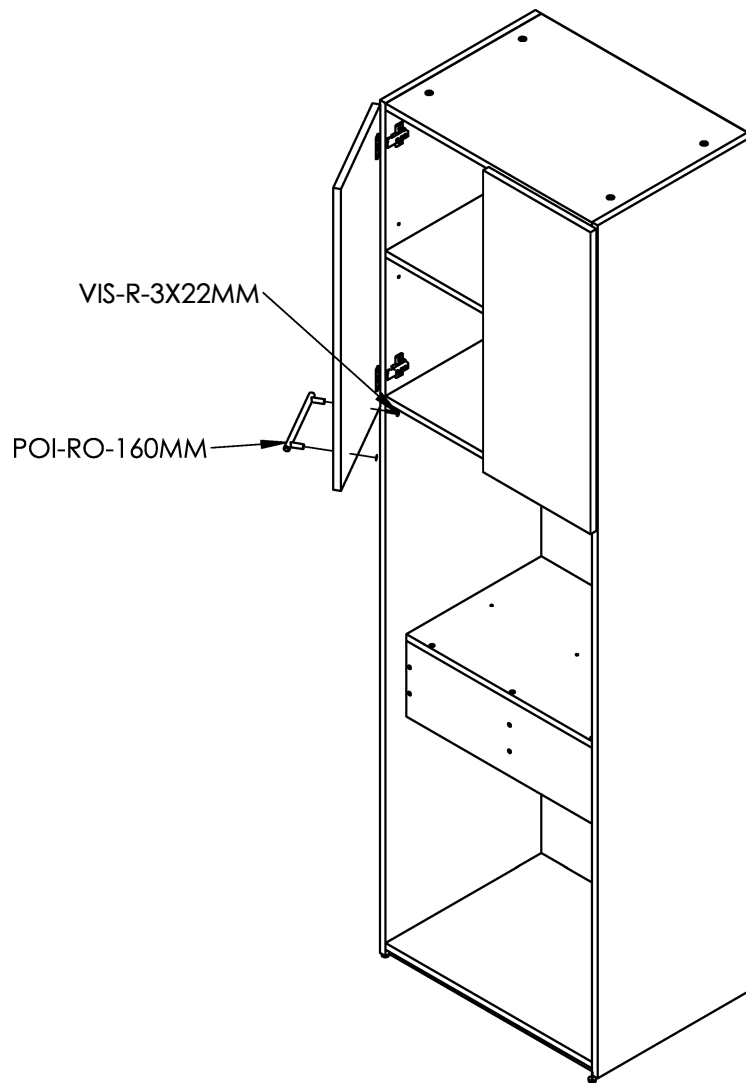

## 12- Assemblage du bureau / Assembling desk

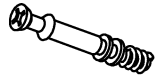

PIÈCE/PART	CAM-D10X35MM	PAT-CL-58
QTÉ/QTY	2	2

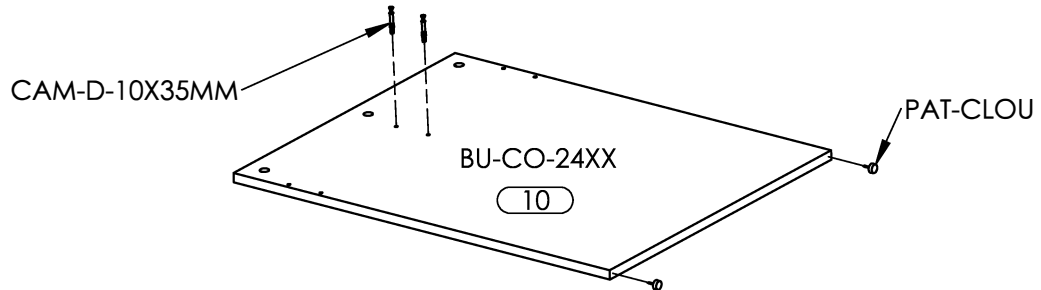

## 13- Assemblage de bureau / Assembling desk



PIÈCE/PART	VIS-W-8X1
QTÉ/QTY	2

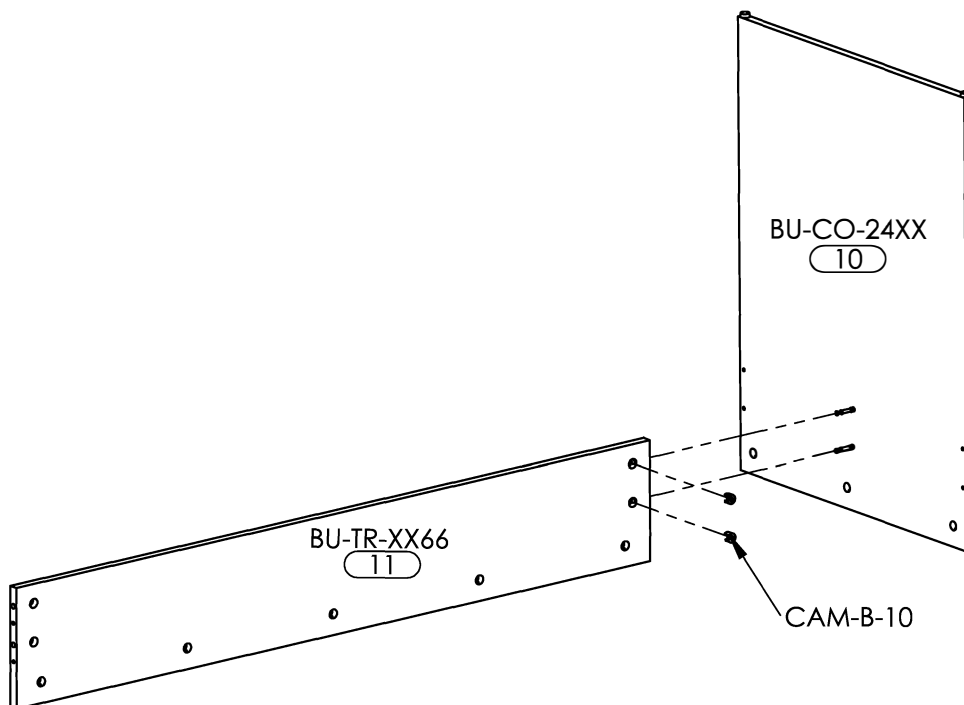

## 14- Assemblage bureau / Assembling desk

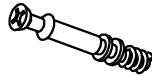

PIÈCE/PART	CAM-D-10X35MM
QTÉ/QTY	8

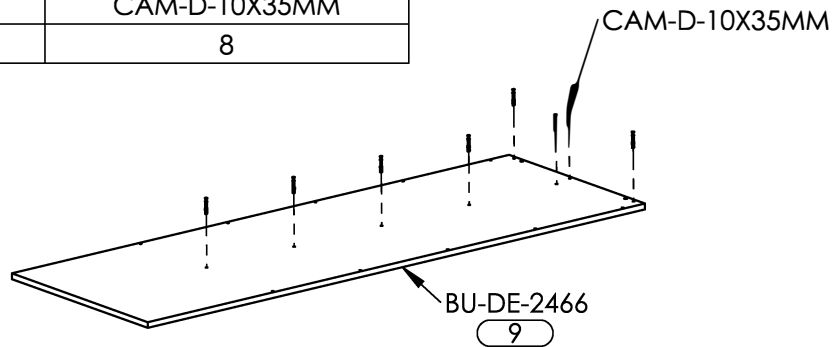

## 15- Assemblage bureau / Assembling desk



PIÈCE/PART	VIS-P-8X114	GOU-B-518X118
QTÉ/QTY	8	2

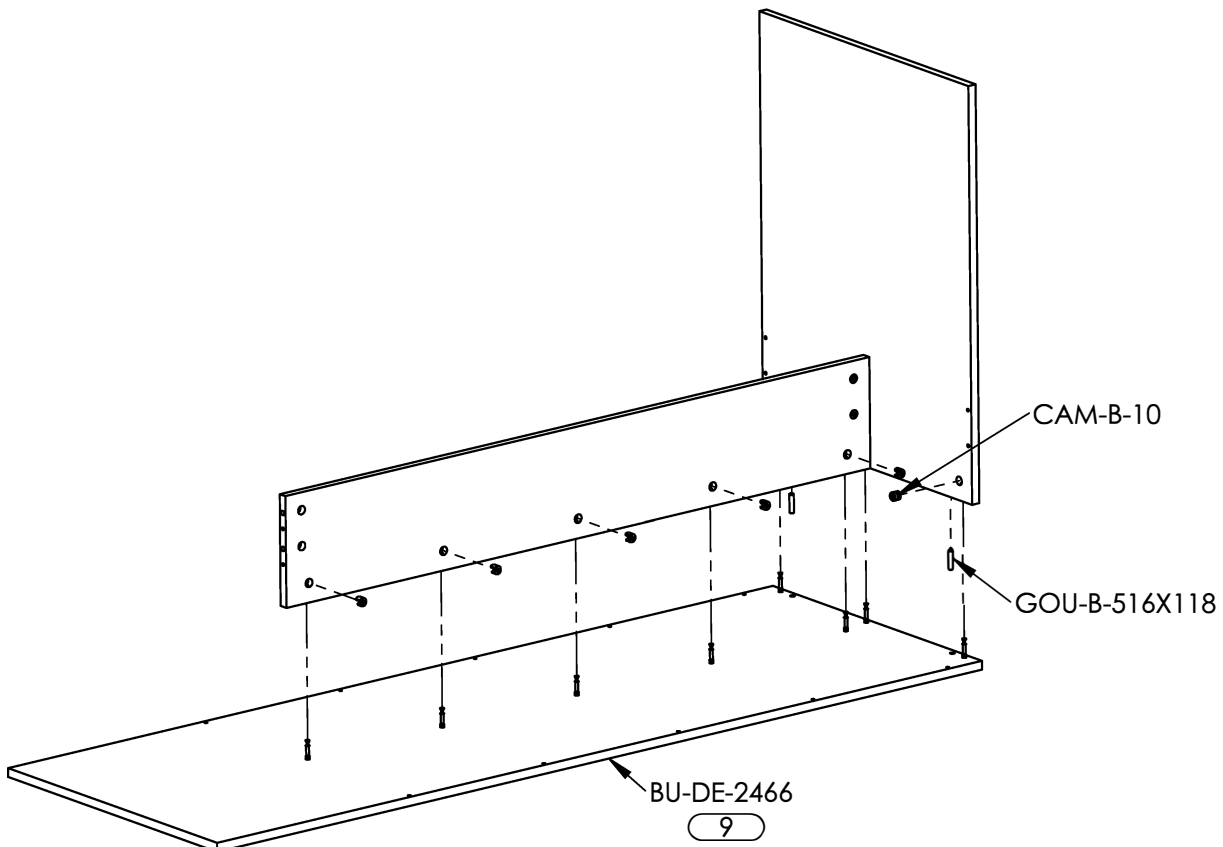

## 16- Assemblage tour bureau / Assembling desk storage unit

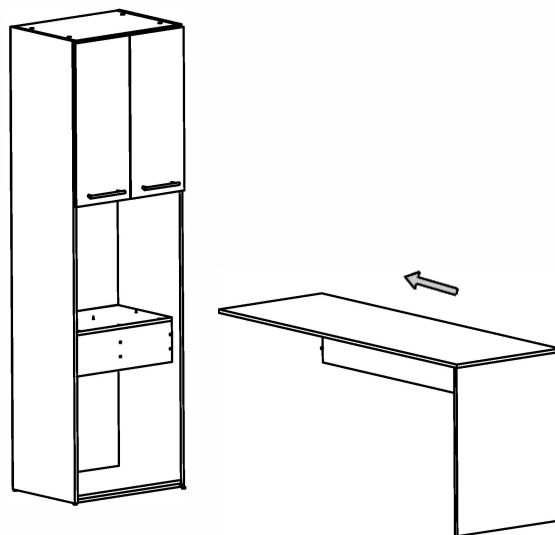

## 17- Assemblage tour bureau / Assembling desk storage unit

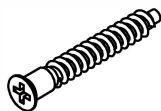

PIÈCE/PART	VIS-C-2	VIS-W-8X1
QTÉ/QTY	2	3

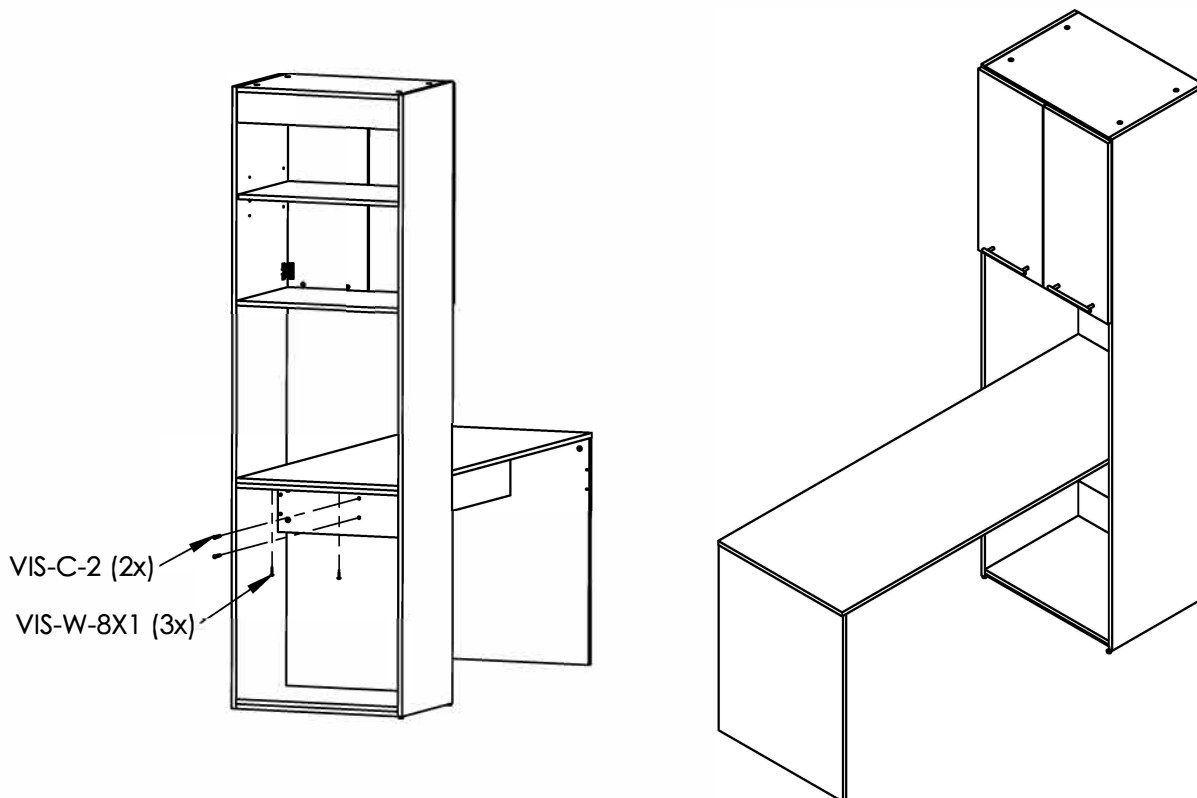

## 18- Assemblage dos/ Assembling back



PIÈCE/PART	Clou / Nail
QTÉ/QTY	26

