

# Instruction for 6 Tier Shelf

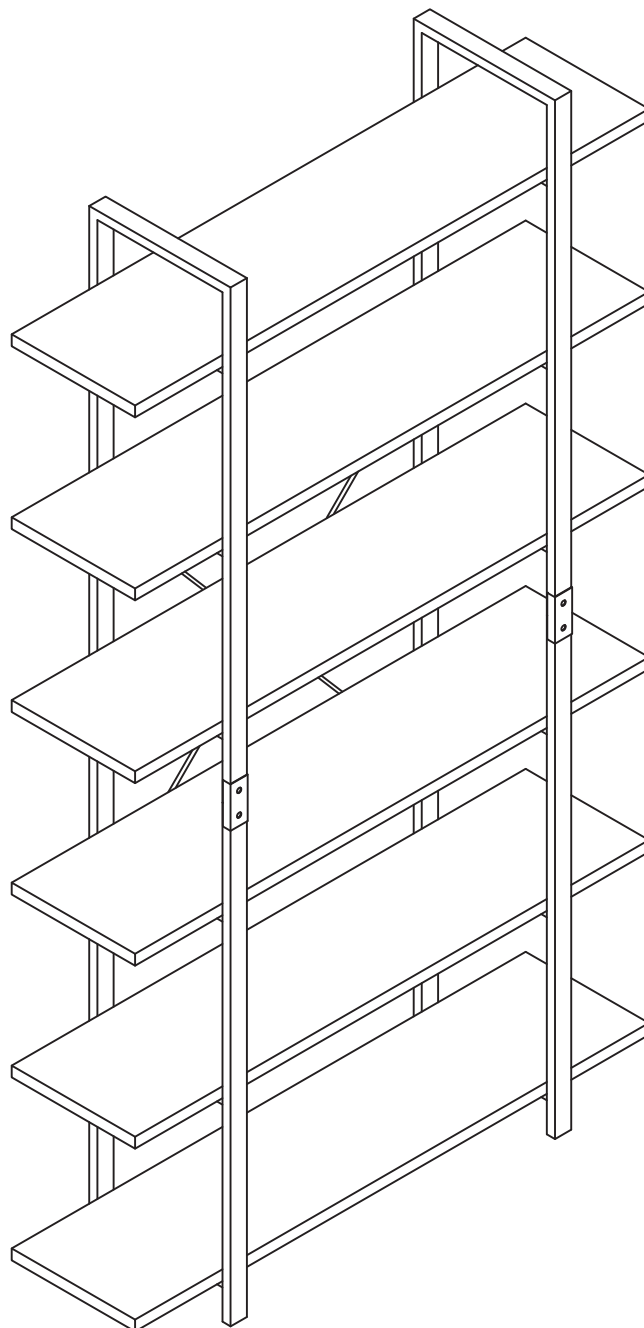

EN



## WARNING

### **Toy must be assembled by adult before use.**

Serious injury may occur from unexpected assembly or use.

1. During the assembly process, keep all parts away from babies or children.
2. Always securely fix this product to the wall. Make sure the wall area to be drilled is free from hidden electrical wires, water and gas pipes.
3. Use of tip-over restraints may only reduce, but not eliminate the risk of tip-over.
4. Unless specially designed to accommodate, do not set heavy objects on top of this product.
5. Place the heaviest items on the lowest shelf.
6. Never allow children to climb or bang on drawers, doors or shelves.

DE



## WARNUNG

### **Spielzeug muss vor Gebrauch von einem Erwachsenen zusammengebaut werden.**

Bei unerwarteter Montage oder Verwendung können schwere oder tödliche Verletzung auftreten.

1. Legen Sie in den Montageprozess alle Teile weg von Babys oder Kindern.
2. Befestigen Sie dieses Produkt immer sicher an der Wand. Um sicherzustellen, dass der zu bohrende Wandbereich entfernt von verdeckten Stromkabeln, Wasser- und Gasleitungen ist.
3. Die Verwendung von Kippsicherungen kann die Gefahr eines Kippens nur verringern, jedoch nicht beseitigen.
4. Setzen Sie bitte keine schweren Gegenstände auf dieses Produkt, es sei denn, dass das Produkt speziell für die Unterbringung konzipiert wird.
5. Legen Sie bitte die schwersten Gegenstände auf das unterste Regal.
6. Erlauben Sie nie Kindern, auf Schubladen, Türen oder Regale zu klettern oder zu knallen.



## AVVERTIMENTO

### **Giocattoli vanno assemblato dai adulti prima dell'utilizzo.**

L'inaspettato montaggio potrebbe provocare i lesioni gravi o mortali.

1. Durante l'assemblaggio, metti tutti i parti fuori dalla portata dei bambini.
2. Sempre fissare saldamente questo prodotto alla parete. Assicurarsi che l'area della parete sia libera dai cavi elettrici nascosti, i tubi dell'acqua e del gas.
3. La restrizione punta-over può ridurre il rischio di punta-over ma non può eliminarlo.
4. A meno che con l'appositamente progettato, Non deporre gli oggetti pesanti sul piano superiore
5. Posiziona le robe più pesante al piano inferiore.
6. Non permettere i bambini di scalare o battere i cassetti, le porte o gli scaffali.



## ATTENTION

### **Le jouet doit être assemblé par un adulte avant utilisation.**

Des blessures graves ou mortelles peuvent survenir à cause de l'assemblage ou l'utilisation inattendue.

1. Pendant le processus de montage, gardez toutes les pièces loin des bébés et des enfants.
2. Fixer toujours sécuritaire ce produit au mur. Assurez-vous que la zone du mur à percer est libre de fils électriques cachés, de conduites d'eau et de gaz.
3. L'utilisation de dispositifs de retenue pour le renversement ne peut que réduire, mais pas éliminer le risque de renversement.
4. Sauf si spécialement conçu pour accueillir, ne posez pas d'objets lourds au sommet de ce produit.
5. Placez les articles les plus lourds sur la tablette la plus basse.
6. Ne laissez jamais les enfants grimper ou cogner sur les tiroirs, les portes ou les étagères.

**ES**

Gracias por comprar productos de Homfa. Por favor, póngase en contacto con nosotros si tiene dificultades con montaje o necesidad de repuestos. El servicio al cliente de Homfa está aquí para ayudarlo.

Correo electrónico: [service@myhomfa.com](mailto:service@myhomfa.com)

Adjunte su nombre de usuario o ID de pedido para que podamos ayudarlo mejor.



## ADVERTENCIA

### **El juguete debe ser montado por un adulto antes de usarlo.**



Se pueden producir lesiones graves o fatales debido al montaje o uso inesperado.

1. Durante el proceso de montaje, mantenga todas las piezas alejadas de bebés o niños.
2. Fije siempre este producto de forma segura a la pared. Asegúrese de que el área de la pared a perforar esté libre de cables eléctricos ocultos, tuberías de agua y gas.
3. El uso de restricciones de vuelco solo puede reducir, pero no elimina el riesgo de que se vuelque.
4. A menos que esté especialmente diseñado para acomodarse, no coloque objetos pesados encima de este producto.
5. Coloque los artículos más pesados en el estante más bajo.
6. Nunca permita que los niños se suban o golpeen los cajones, puertas o estantes.

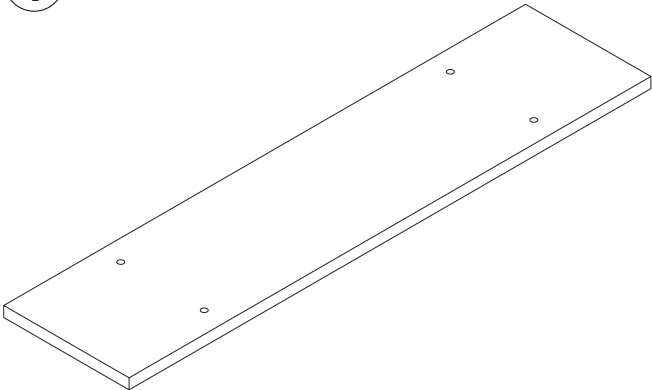
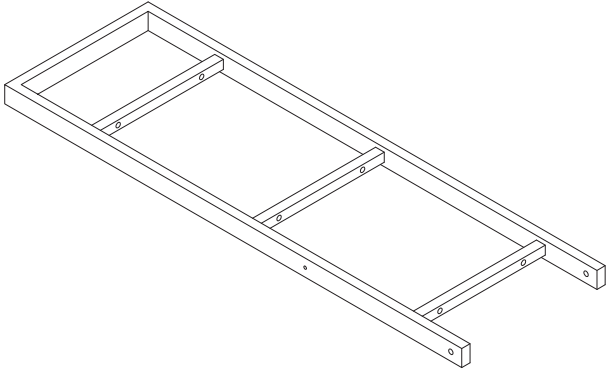
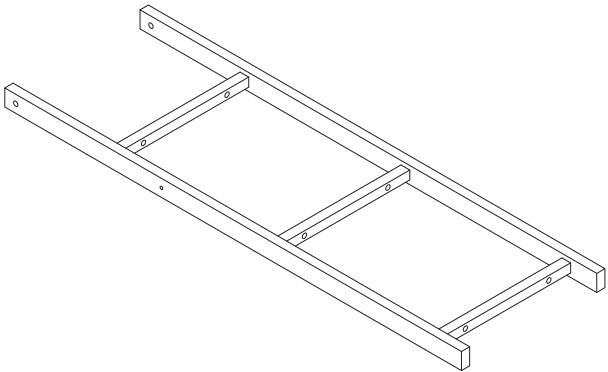
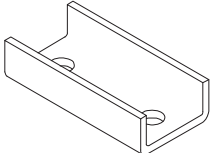
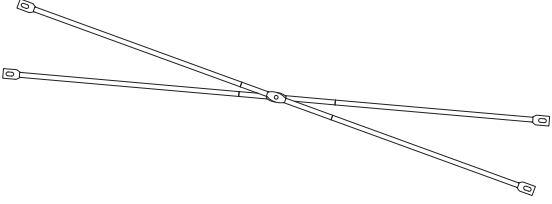
# Parts List(EN) / Teile Liste(DE)

<p>1</p>  <p>6PCS</p>	<p>2</p>  <p>2PCS</p>
<p>3</p>  <p>2PCS</p>	<p>4</p>  <p>4PCS</p>
<p>5</p>  <p>1PC</p>	

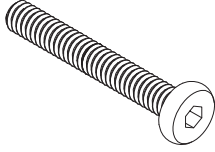
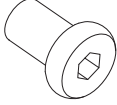
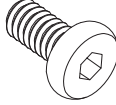
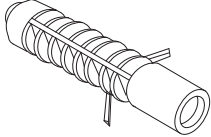
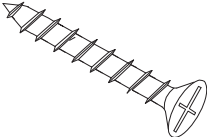
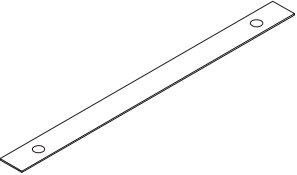

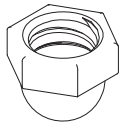
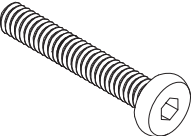
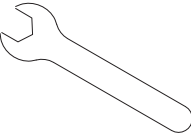
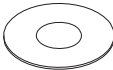
## Parts List(EN) / Teile Liste(DE)

<p><b>A</b></p> 	<p><b>B</b></p> 	<p><b>C</b></p> 
<p>M6x35mm      24PCS</p>	<p>M6x15mm      8PCS</p>	<p>M6x12mm      8PCS</p>
<p><b>D</b></p> 	<p><b>E</b></p> 	<p><b>F</b></p> 
<p>M3      1PC</p>	<p>Φ6x30mm      2PCS</p>	<p>M3.5x39mm      2PCS</p>
<p><b>G</b></p> 	<p><b>H</b></p> 	<p><b>I</b></p> 
<p>L250mm      2PCS</p>	<p>M4      2PCS</p>	<p>M4      4PCS</p>
<p><b>J</b></p> 	<p><b>K</b></p> 	<p><b>L</b></p> 
<p>M4x30mm      4PCS</p>	<p>M7      1PC</p>	<p>Φ6.5x2x14mm      4PCS</p>

# Assembly Steps(EN) / Montageschritte(DE)

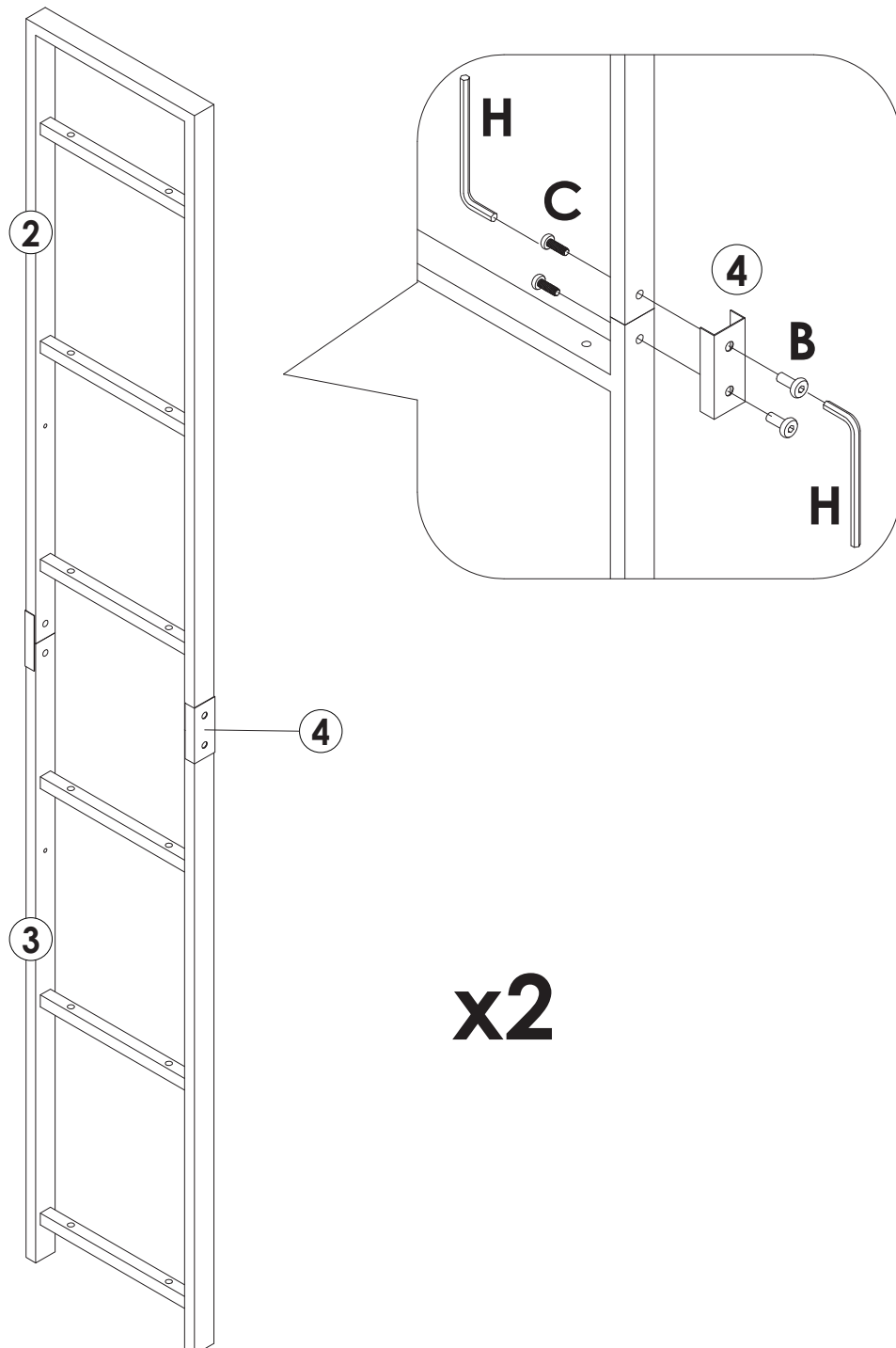
## STEP 1



	<b>B</b> x 8PCS
	<b>C</b> x 8PCS
	<b>H</b> x 2PCS

## Assembly Steps(EN) / Montageschritte(DE)

### STEP 2

EN: When installing the crossing bars for stability, the four mounting holes must be on the same side.



DE: Bei der Installation (zur Sicherung) der Querlatten müssen sich die vier Befestigungslöcher auf derselben Seite befinden.

FR: Lors de l'installation (pour la fixation) des barres transversales, les quatre trous de montage doivent être du même côté.

IT: Durante l'installazione (per il fissaggio) delle traverse, i quattro fori di montaggio devono essere sullo stesso lato.

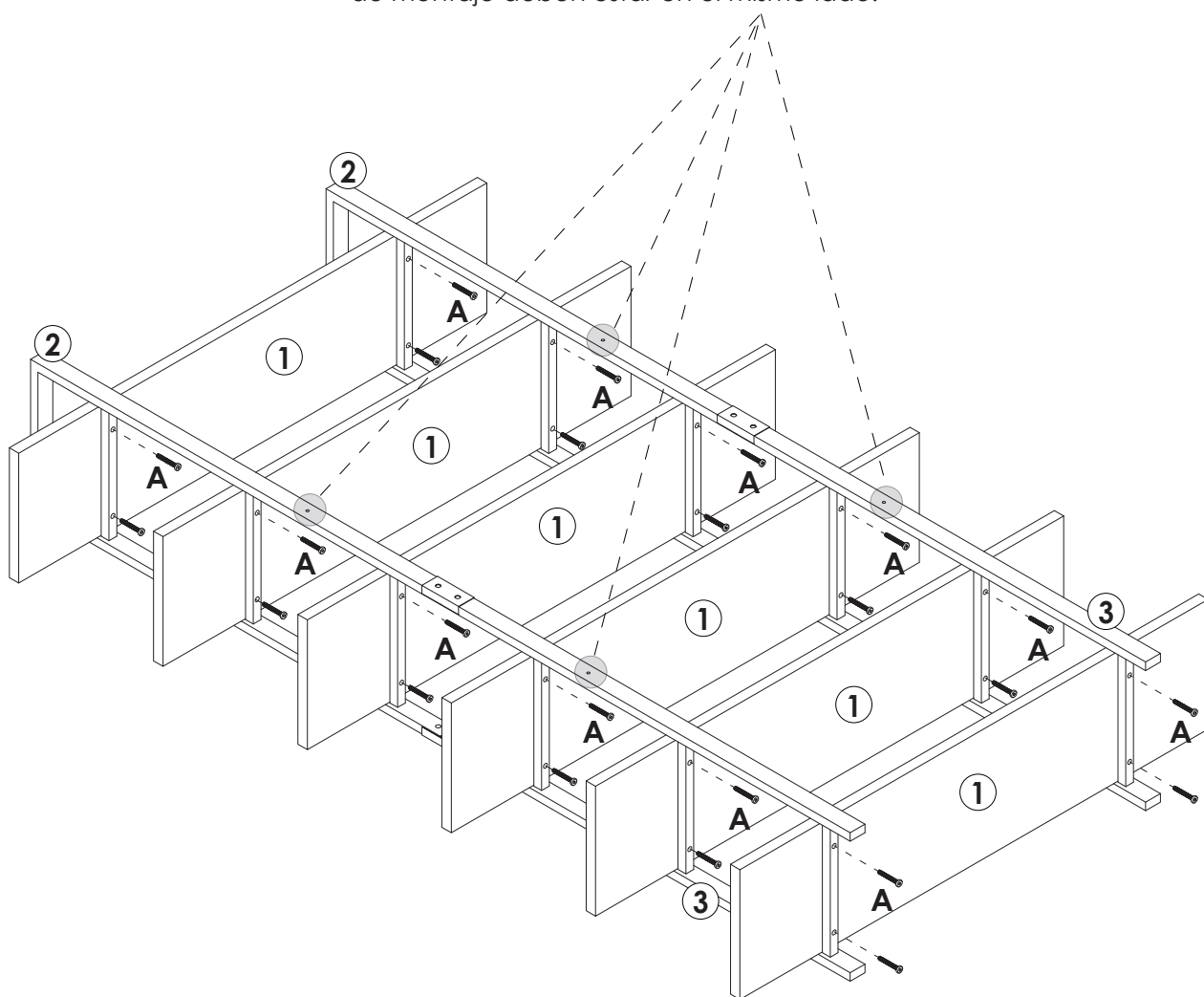
ES: Al instalar las barras transversales (para estabilizar), los cuatro orificios de montaje deben estar en el mismo lado.





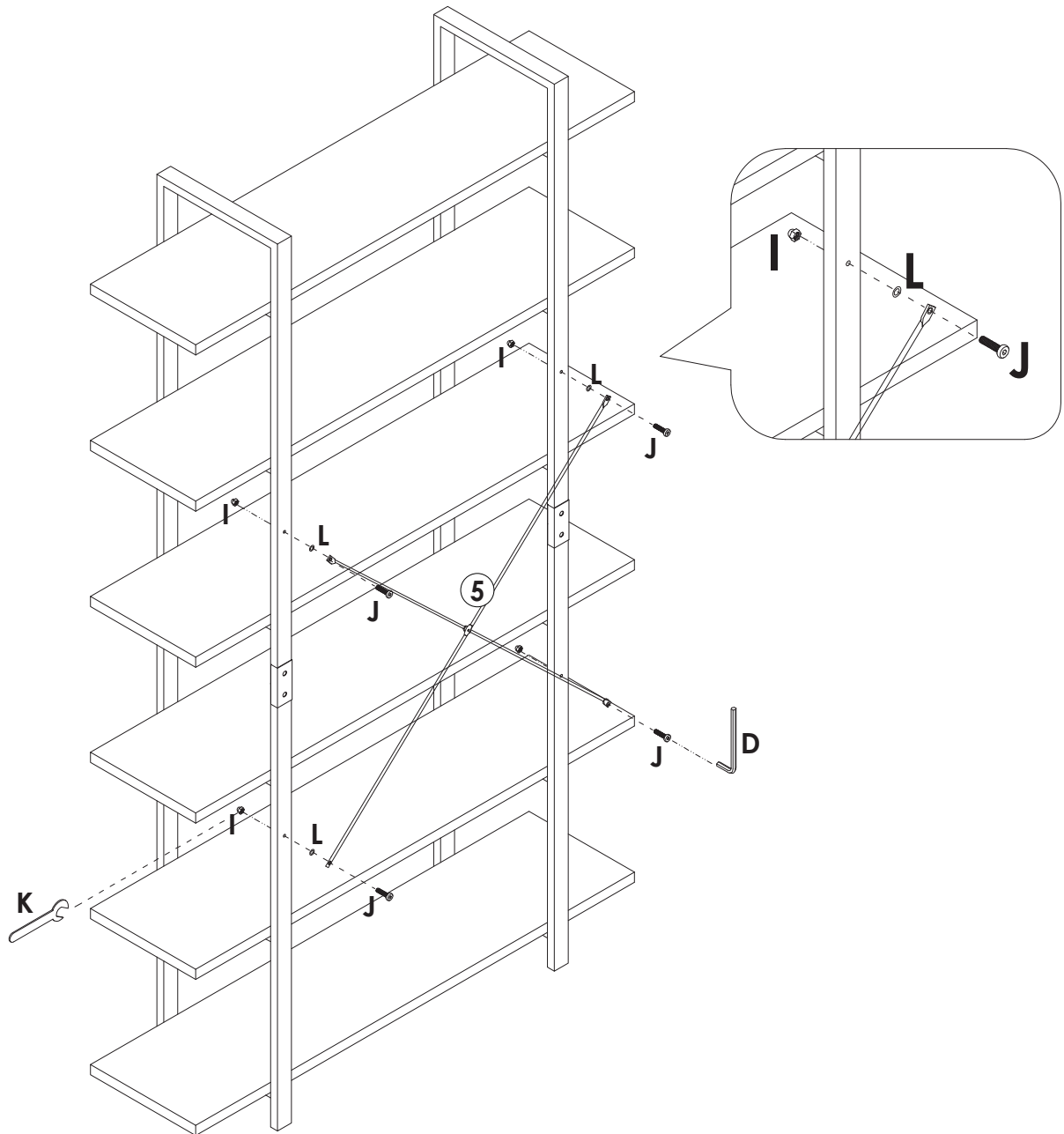

	A x 24PCS
	H x 1PC

# Assembly Steps(EN) / Montageschritte(DE)

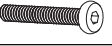
## STEP 3





	I x 4PCS
	J x 4PCS
	K x 1PCS
	D x 1PCS
	L x 4PCS

# Assembly Steps(EN) / Montageschritte(DE)

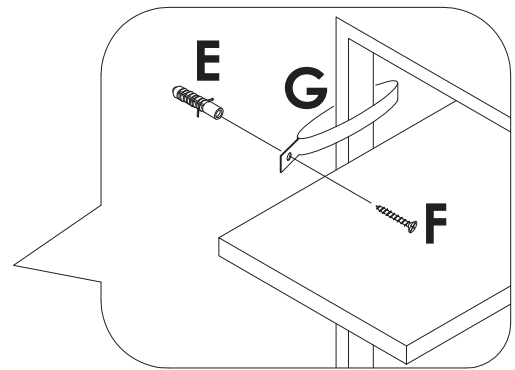
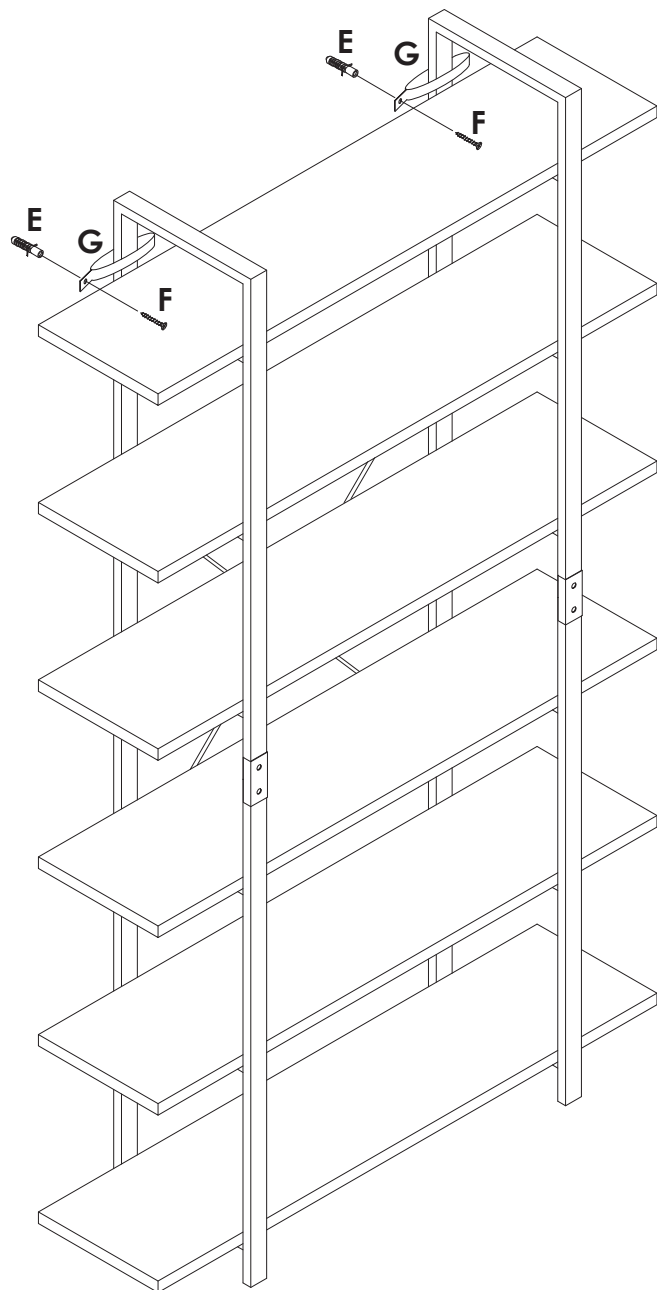
## STEP 4



	<b>E</b> x 2PCS
	<b>F</b> x 2PCS
	<b>G</b> x 2PCS

**STEP 5**

