

Adjustable-Height Executive Desk

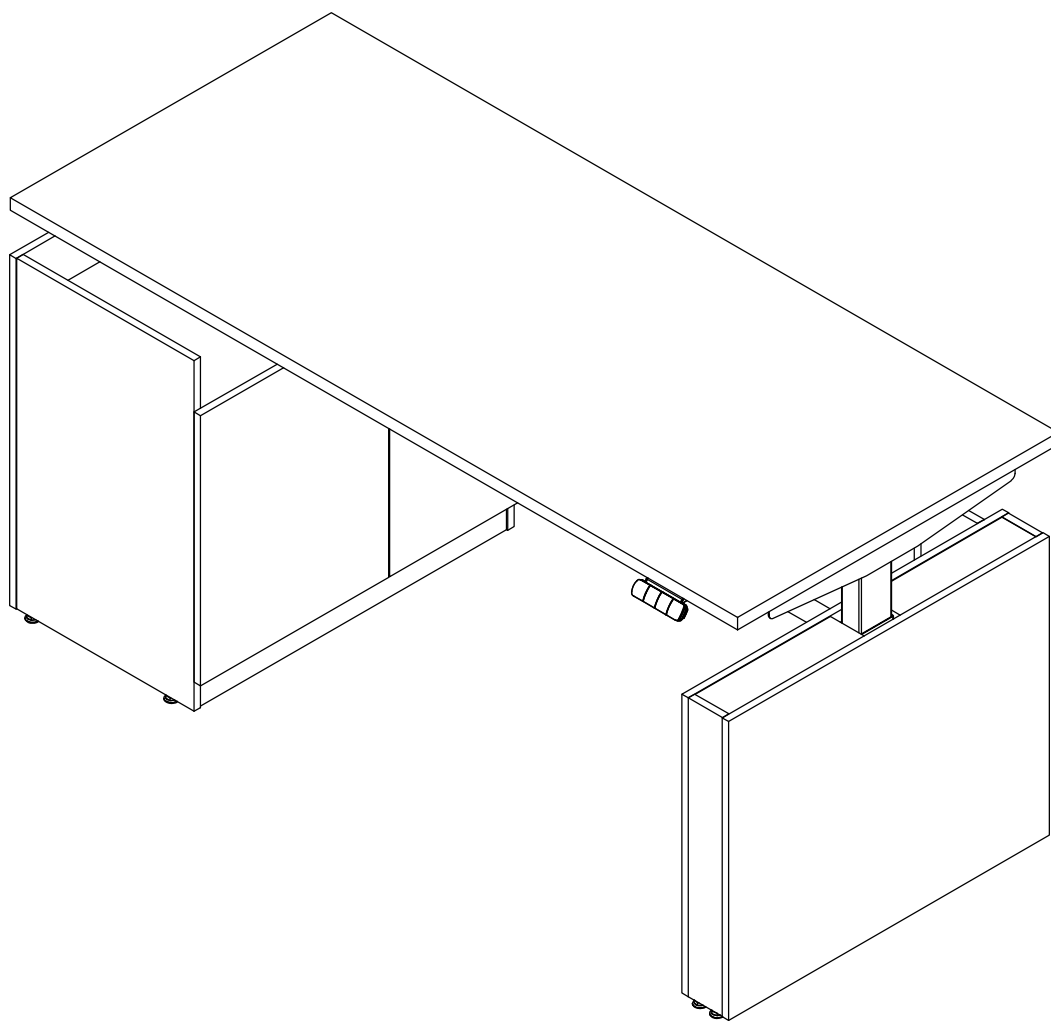

67x30 — Holds up to 220 lb (99.8 kg)



People Required for Assembly

INCLUDED PARTS

*Desktop and leg kit ship in separate boxes and could arrive in separate deliveries.

Box 1 of 4

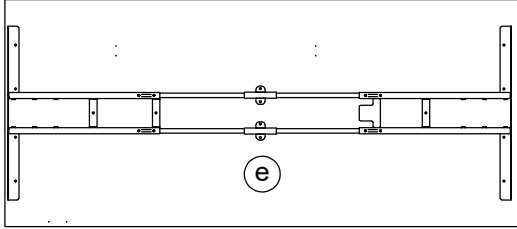

x1

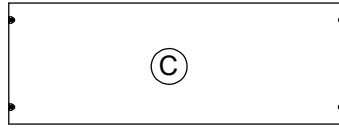

x1

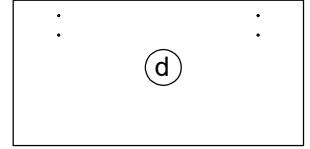

x1

Box 2 of 4

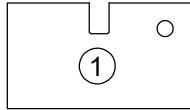
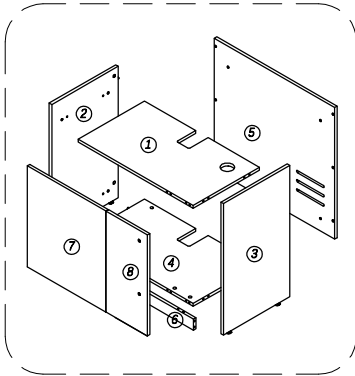

x1

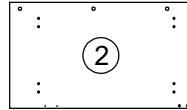

x1

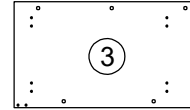

x1

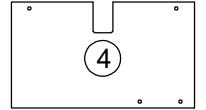

x1

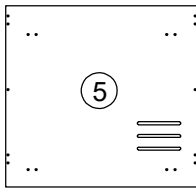

x1



x1

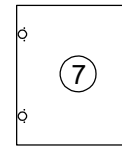

x1

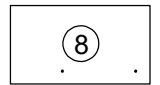

x1

Box 3 of 4

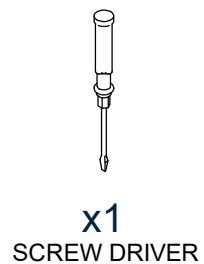
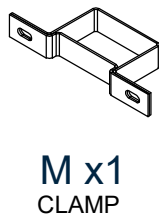
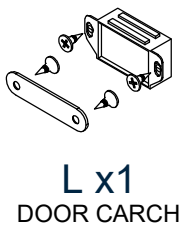
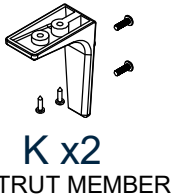
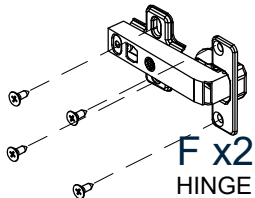
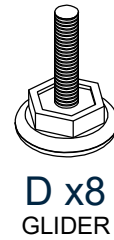
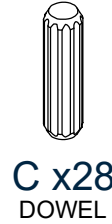
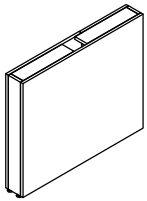

INCLUDED PARTS

*Desktop and leg kit ship in separate boxes and could arrive in separate deliveries.

Box 4 of 4

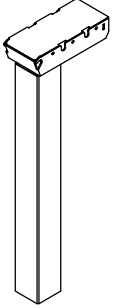

x2
PILLARS

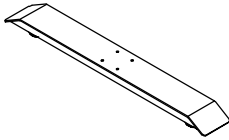

x2
FEET

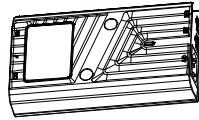

x1
ADAPTERS

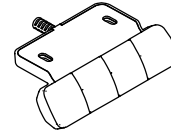

x1
CONTROLLER



x8
M6 16MM SCREWS



x2
ST5 16MM SCREWS

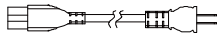

x1
POWER CORD

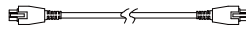

x1
CONNECTER CABLE

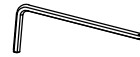

x1
HEXAGON WRENCH



x10
CABLE CLIPS

WARM REMINDER



Please make sure the height adjustable desk will not come into contact with any obstacle while lifting, the table top cannot be next to the wall, and the wires should be long enough to lift the desk freely.



Warning

Please make sure the fingers are put anywhere visible.



Please keep the children away from the desk to avoid hurt or electric shock.



Please keep the electrical parts away from the liquid.



Please do not put any item higher than 20cm below the desk.



Please do not operate the desk continuously for more than 2 minutes to avoid damage to the motor.



If the power supply is cut off or not plugged, you need to refer to the use instruction and reset.



Desk Assembly

Box 1&4

1

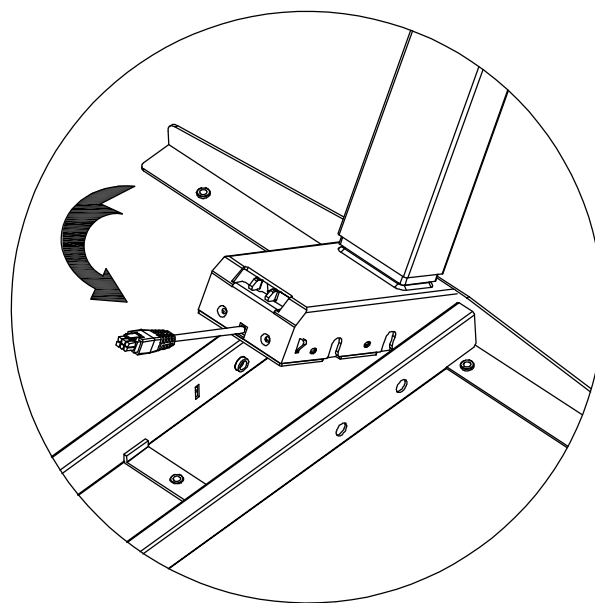
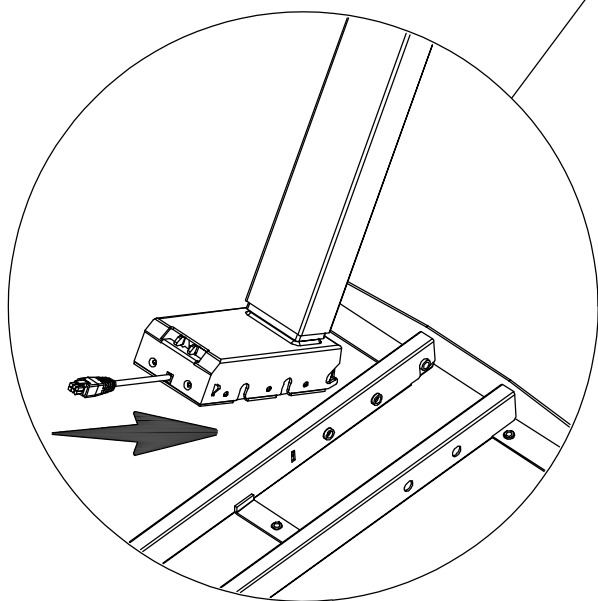
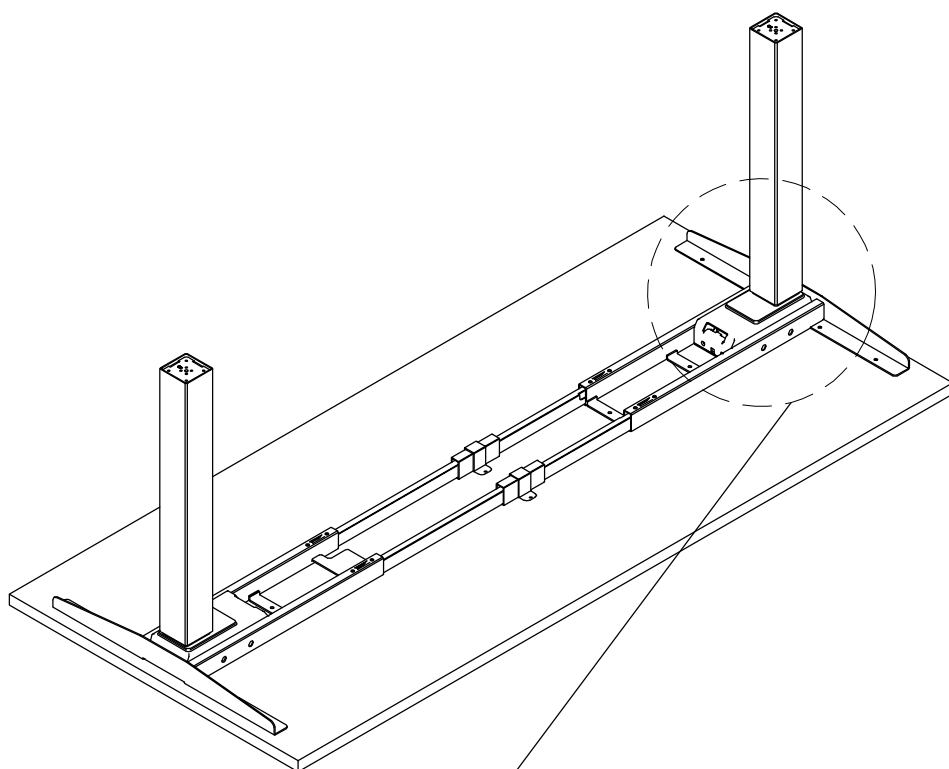

·Place the uprights as shown, with the rear groove fitting into the protruding part of the side panels. Rotate the upright until you hear a "click" sound, indicating that the front locking tongue of the upright has locked into the corresponding position of the frame.

2



[8]



[1]

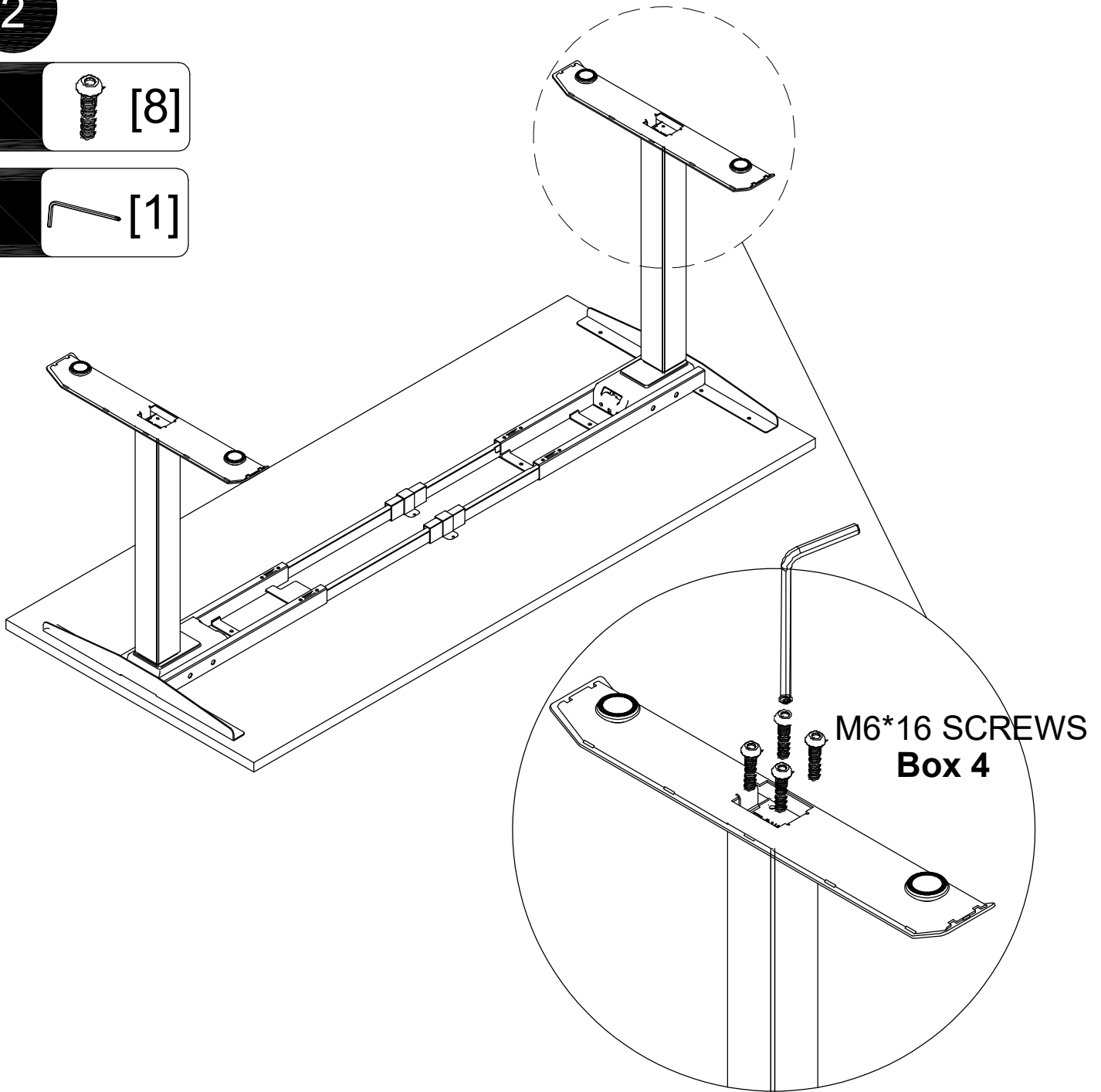

- Place the feet as shown, using an M4 wrench (18), to secure the M6*16 screws (8) to the feet and upright.

3

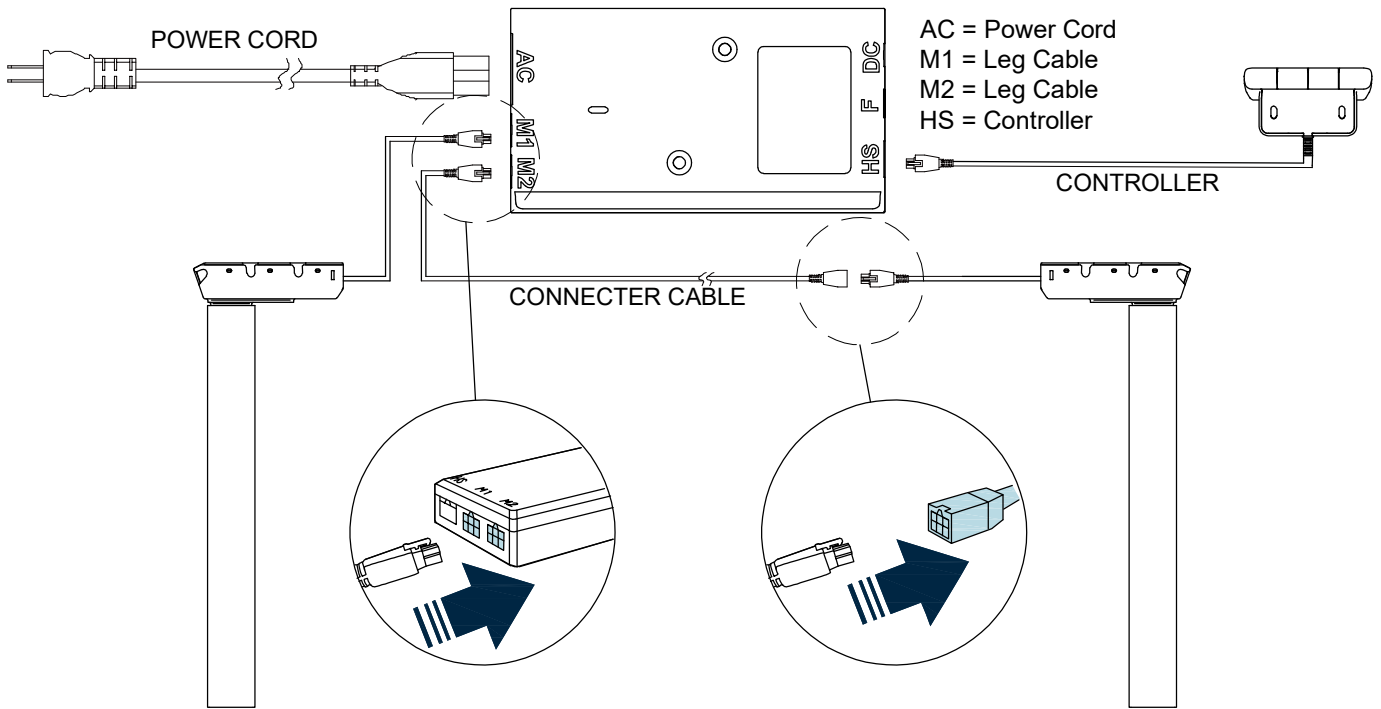
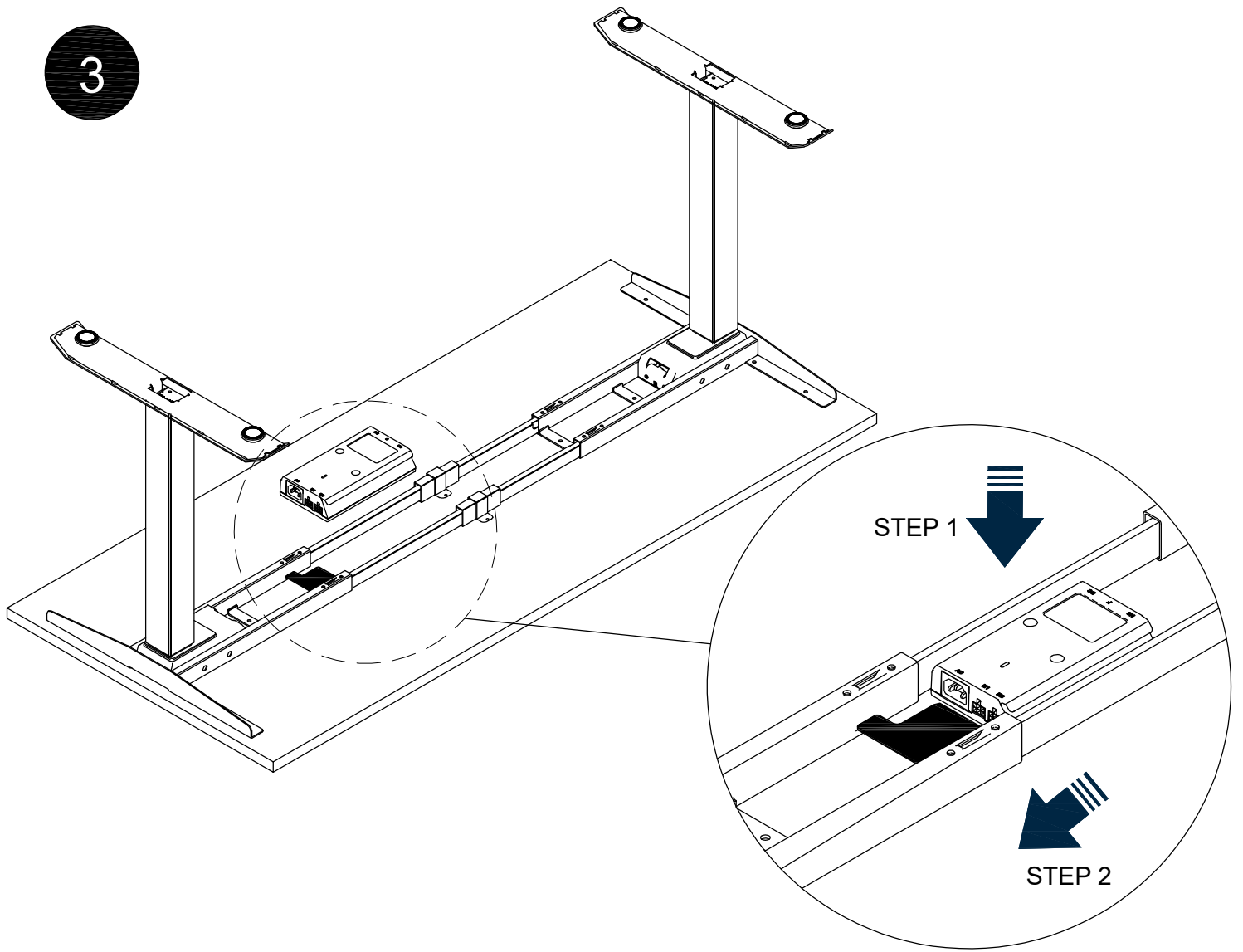

• Connect the hand controller, adapter, upright, etc. parts as shown in the diagram.

4

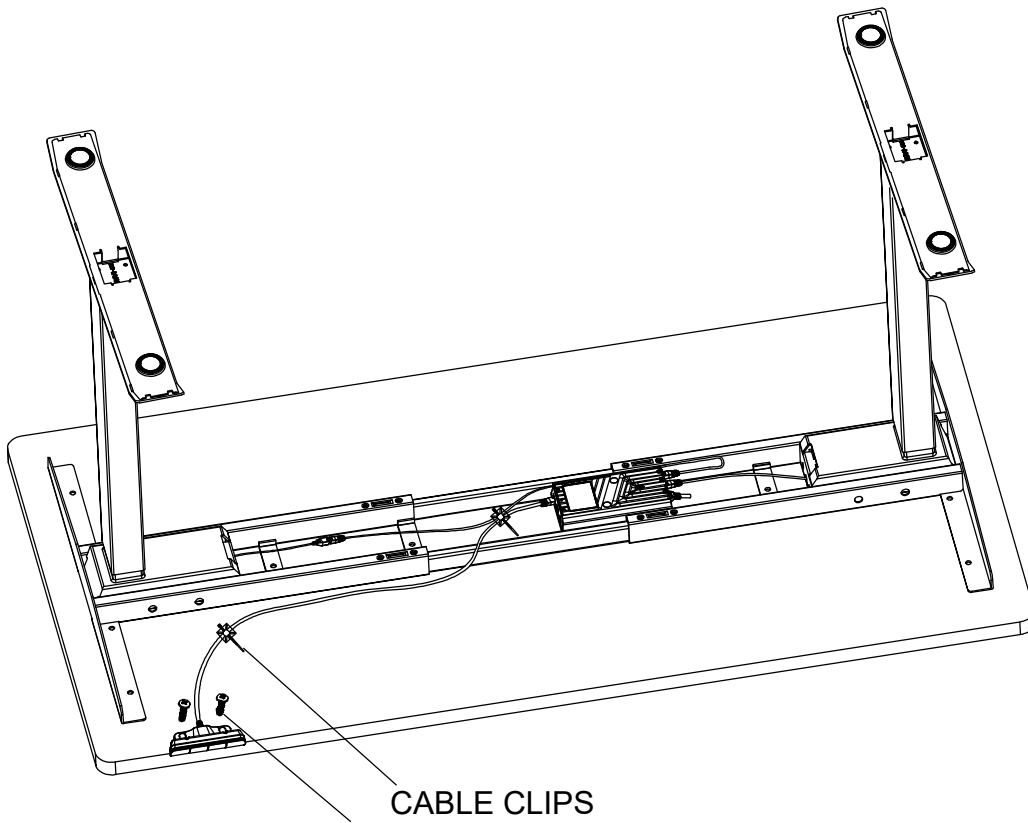

ST5*16 bolt

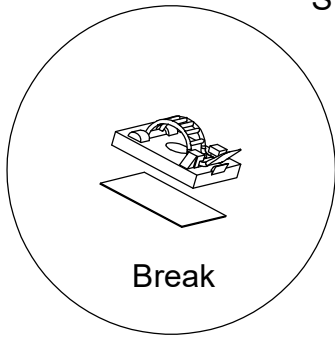

Break

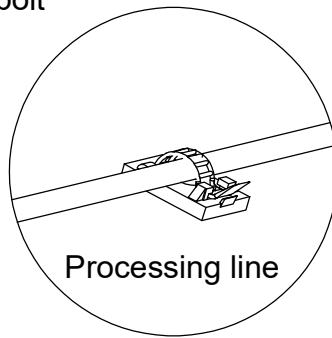

Processing line

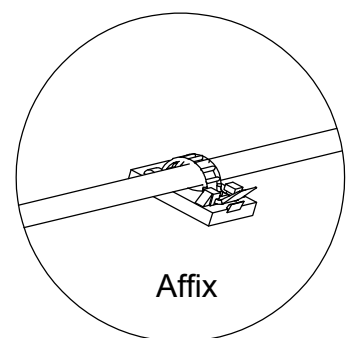

Affix

- Secure the hand controller with ST5*16 screw.

5

- Please reset before use.

NOTE(RESET PROCEDURE):

Hold the "Up" button until the desk reaches its maximum height, then hold "Up" button again until the LED display reads "RST", then release. Hold the "DOWN" button until the desk lowers a bit more, then slightly rises and stops, then release. Your desk is now ready to use.

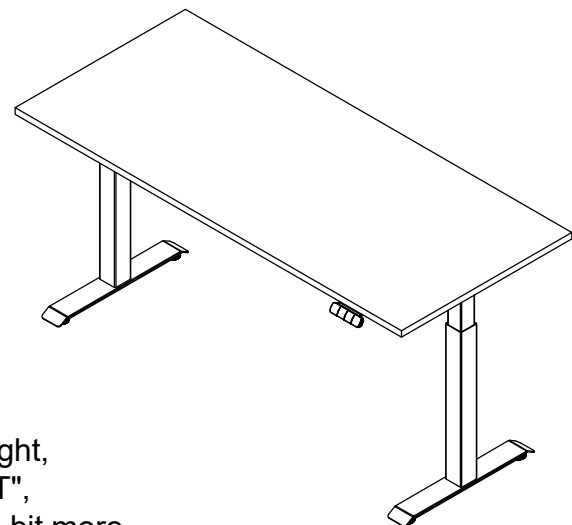

Cabinet Assembly

Box 2

1

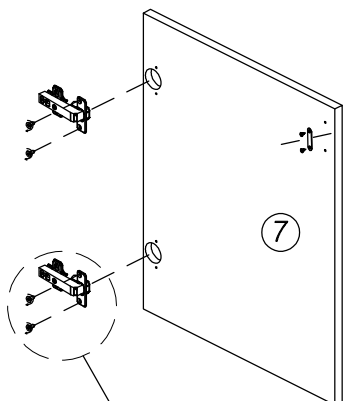
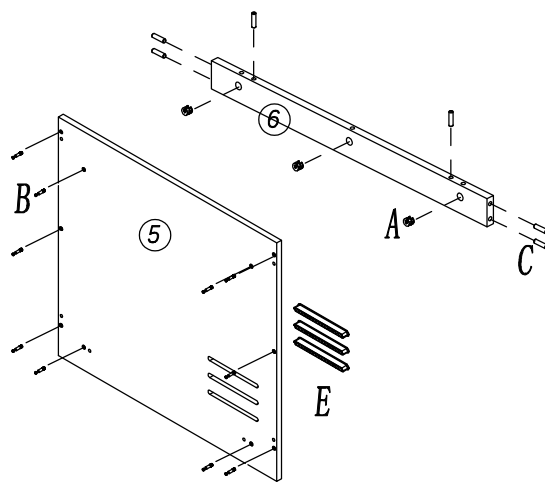
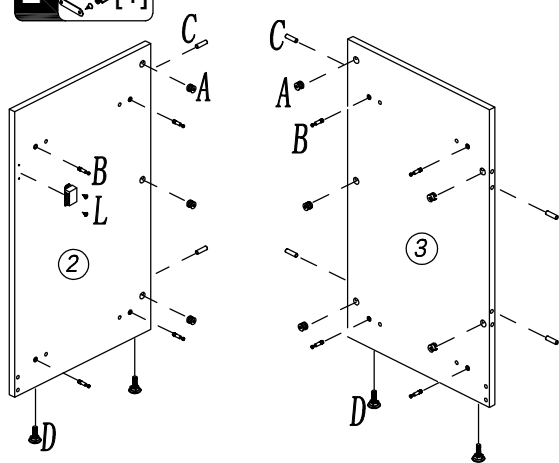
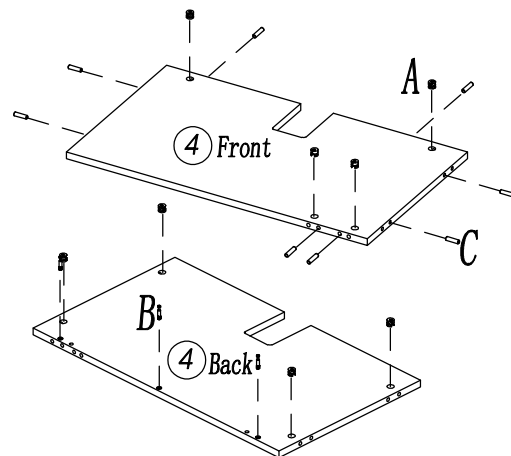
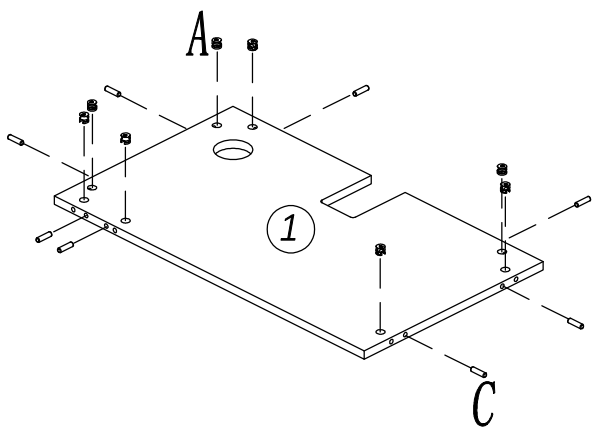
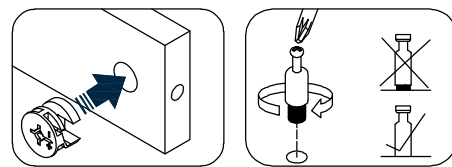

Note: Extra screws to lock cabinets

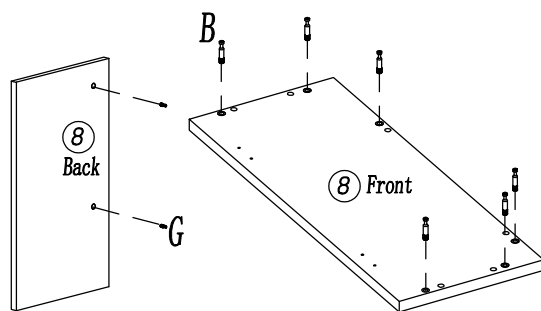

Cabinet Assembly

2

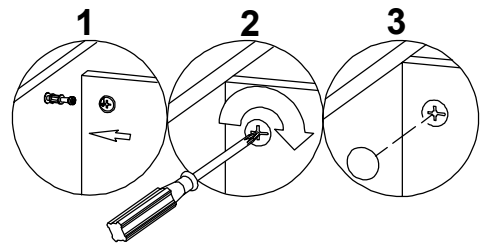

STEP 1

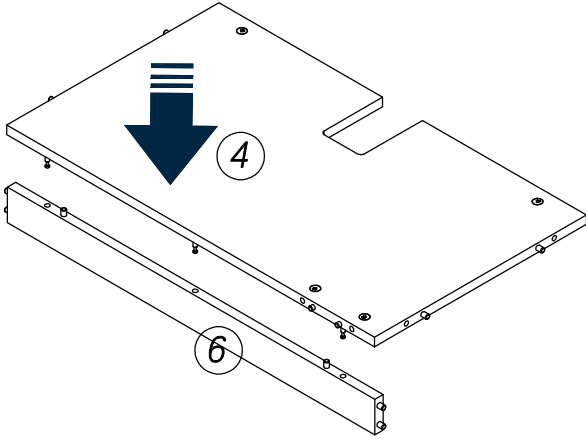

STEP 2

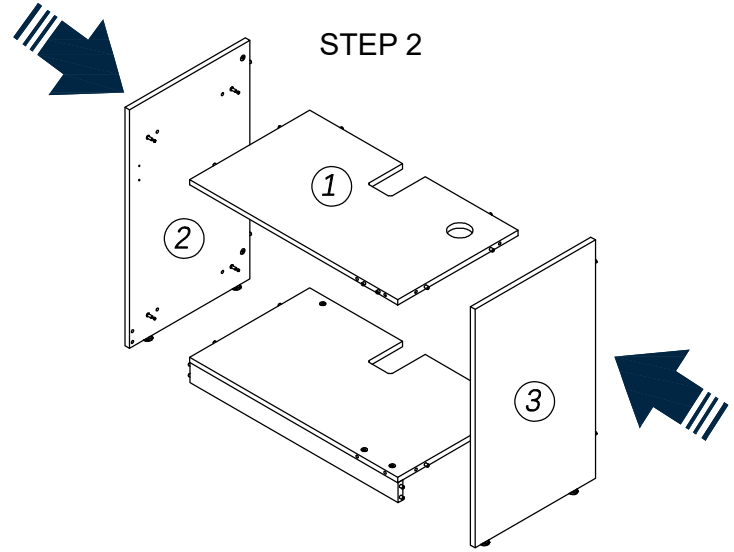

STEP 3

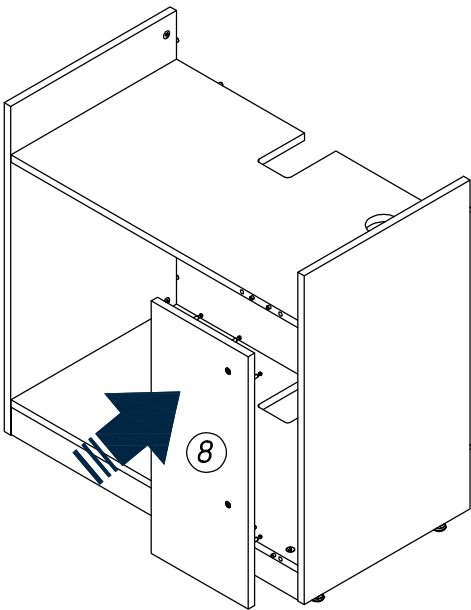

STEP 4

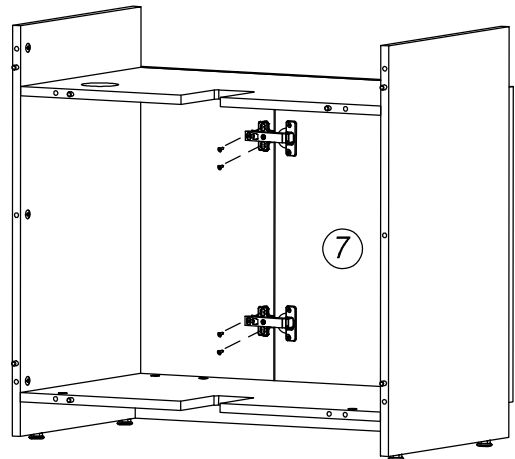

STEP 5

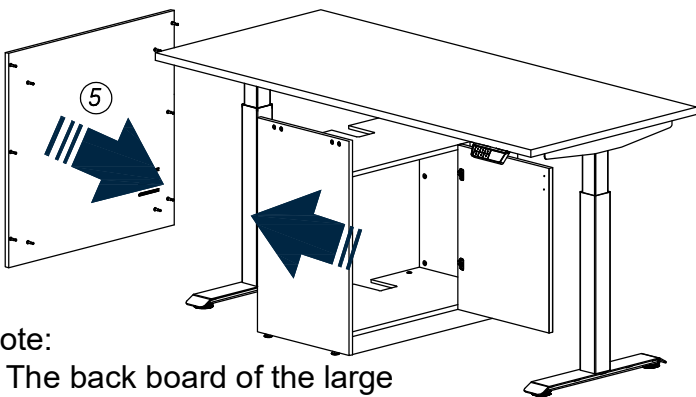

STEP 6

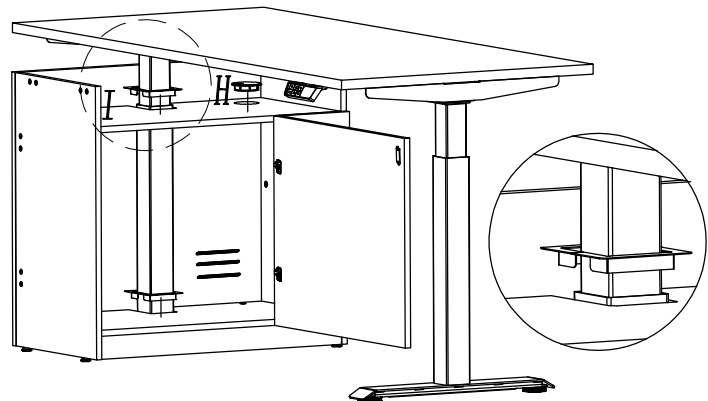

Note:
The back board of the large cabinet is installed after the lifting table is placed;

Complete Assembly

3

STEP 1

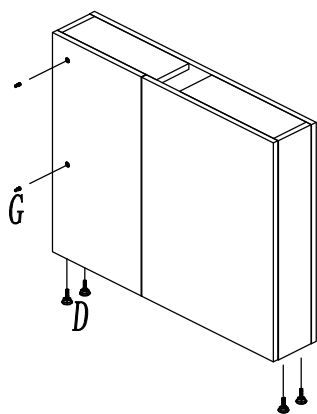

Box 3

STEP 2

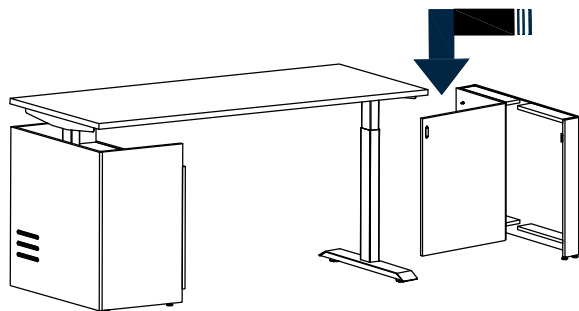

STEP 3

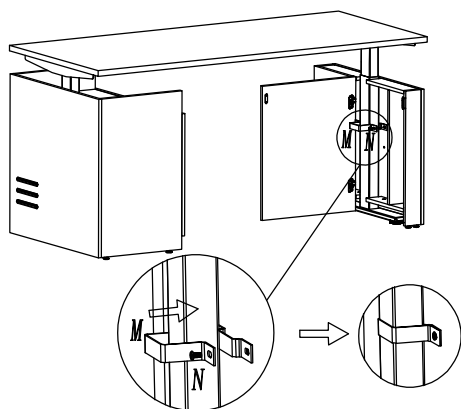
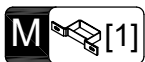

STEP 4

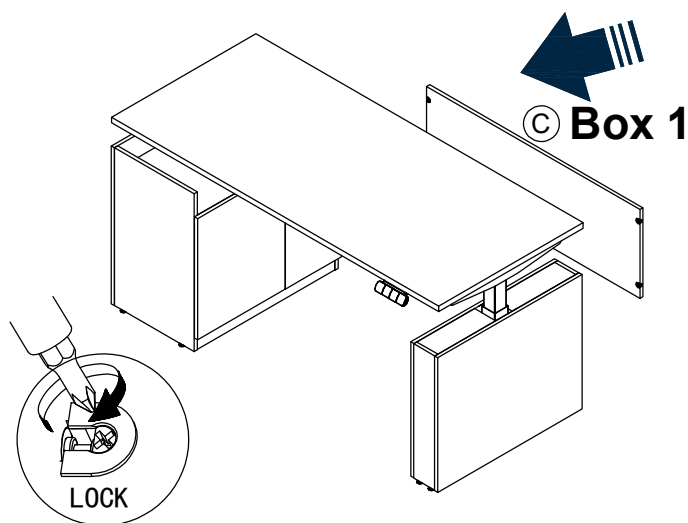

STEP 5

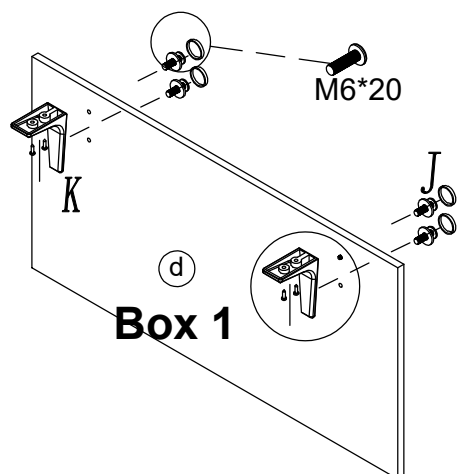

Box 1

STEP 6

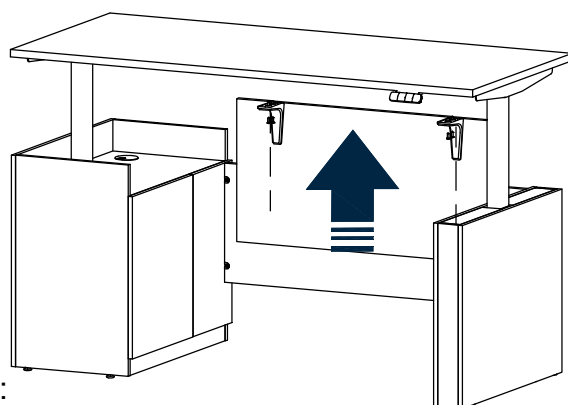

Note:

Secure the privacy panel to the tabletop. (Before installation, the tabletop should be raised to its maximum height)

Use Instruction

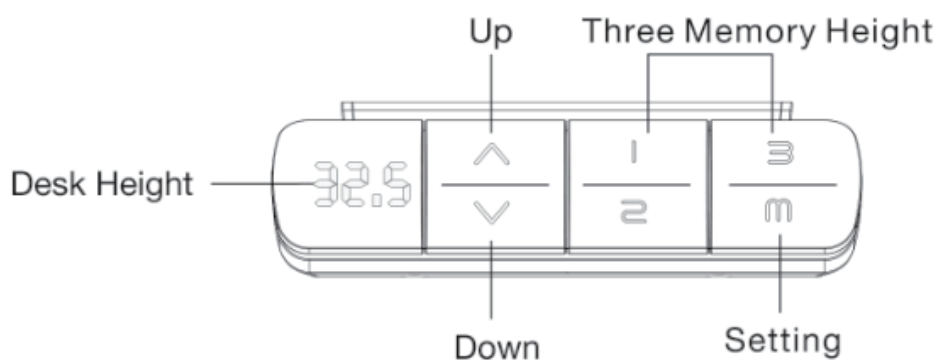

Note

1. Please make sure no obstacles during up and down.
2. Don't make the desktop attach to wall.

Suggestion

Set height 1 as the most comfortable height when you sitting; set height 2 as the most comfortable height when you standing; set height 3 and height 4 as what you needed

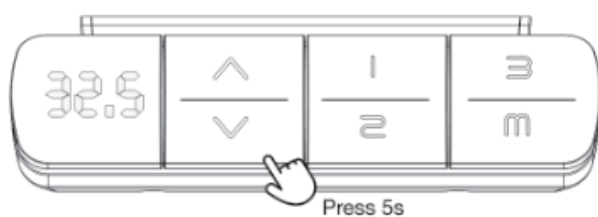

Abnormal Reset

Condition

When the display shows an Error code: E07-E09, (Even after reset, the display still shows error code) it doesn't work when pressing any button.

Operation

Keep pressing the "down" button for 5 seconds, the display shows RST. Release the button, and press the "down" button again to reset.



Set Highest Limit

Press "M" button, the display shows "s-", then release the button. Press the "up" button, after the display flashes, release the button. Then press "M" button again for 2 seconds, and when the display shows "999", the setting is completed.

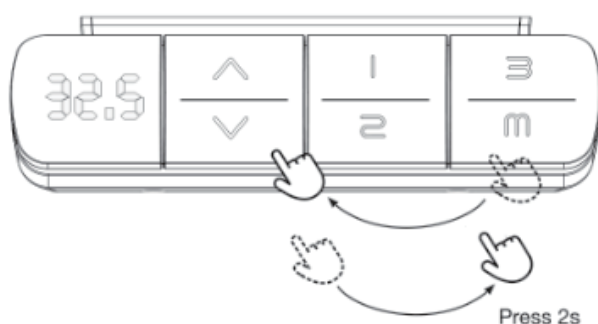

Set Lowest Limits

Press "M" button, the display shows "s-", then release the button; Press the "down" button, after the display flashes, release the button; Then press "M" button again for 2 seconds, and when the display shows "000", the setting is completed.

Use Instruction

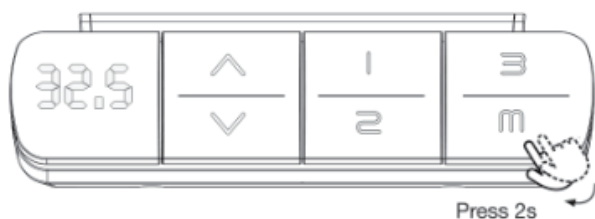

Cancel Limits

Press "M" button, the display shows "s-", then release the button; Press "M" button again for 2 seconds, the display shows "555"; the highest and lowest limit heights would be cancelled at the same time.

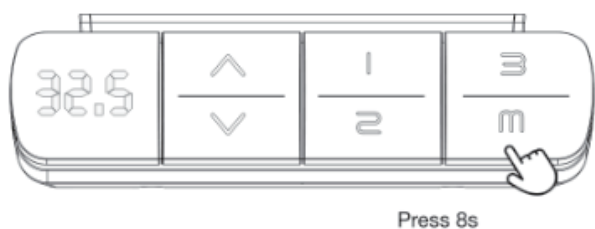

Locking

Press "M" button, the display shows "s-", then keep pressing "M" button for 5 seconds again till the display returns the number, continue to hold the "M" button for 3 seconds till the display shows LOC to complete the lock setting.

Unlocking

In the "LOC" status, press the "M" button for 8 seconds. When the "LOC" back to height display, it is unlocked.

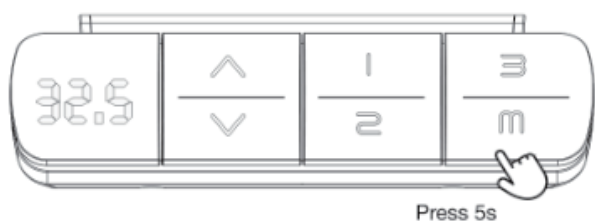

Adjust the actual minimum height number

Hold the "UP" button on the Keypad until the desk reaches the maximum height, then release; Hold the "UP" button again until display flashes "RST".
press "M" button for 5 seconds till the display shows height No. and keep flashing; Then press "up" or "down" button to adjust the height No. to be same as actual minimum height; then release the button till the display back to RST and flashing. At last, press "down" button to finish the reset process, the whole setting is completed.

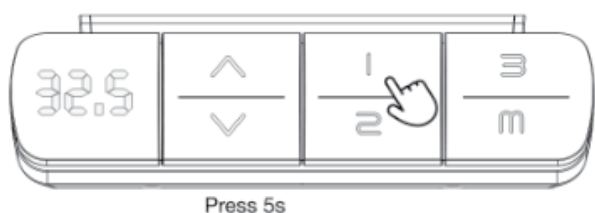

Switch the One-Touch & Constant-Touch memory program

Hold the "UP" button on the Keypad until the desk reaches the maximum height, then release; Hold the "UP" button again until display flashes "RST".
Press button "1" for 5 seconds to switch the memory setting way:
"10.1" means the One-Touch memory program.
"10.2" means the Constant-Touch memory program
At last, press "down" button to finish the reset process, the whole setting is completed.

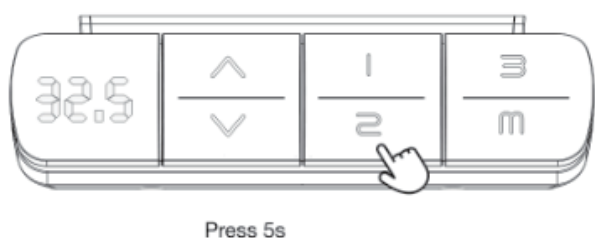

Switch cm or inch display unit

Hold the "UP" button on the Keypad until the desk reaches the maximum height, then release; Hold the "UP" button again until display flashes "RST".
Press button "2" for 5 seconds to switch cm or inch height No. display;
"10.3" means the unit of height No. is cm.
"10.4" means the unit of height No. is inch.
At last, press "down" button to finish the reset process, the whole setting is completed.

Use Instruction

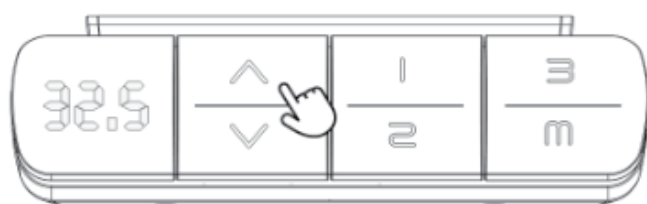

Press 5s

Anti-collision sensitivity setting

Hold the "UP" button on the Keypad until the desk reaches the maximum height, then release; Hold the "UP" button again until display flashes "RST"

Press "up" button for 5 seconds to adjust the anti-collision sensitivity

"10.5" -not sensitive

"10.6" -moderately sensitive

"10.7" -very sensitive

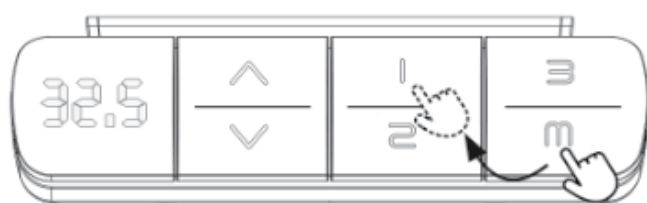

Memory Position Setting

Press "M" button, when display shows "S-" choose and press one of memory button and this position will be remembered; Press "up" or "down" button to reach the height you wanted, and repeat the above process to set other memory heights.

RESET PROCEDURE

Hold the "Up" button until the desk reaches its maximum height, then hold "Up" button again until the LED display reads "RST", then release. Hold the "DOWN" button until the desk lowers a bit more, then slightly rises and stops, then release. Your desk is now ready to use.

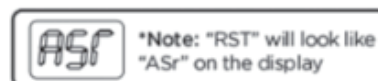

CODE	DESCRIPTION	TROUBLESHOOTING SOLUTION
------	-------------	--------------------------

CODE	DESCRIPTION	TROUBLESHOOTING SOLUTION
H01	Overheated	The desk motor has a 10% duty cycle to protect from overheating. For example, in a 20 minute period if your desk motor is activated for 2 minutes you will want to let it rest for 18 minutes. Otherwise you may see an H01 code on your keypad."
E01-E06	Firmware or connectivity issues	Check all cables to ensure they're all firmly plugged in, and perform Reset procedure above
E07-E13	Legs are uneven	Perform Reset procedure above

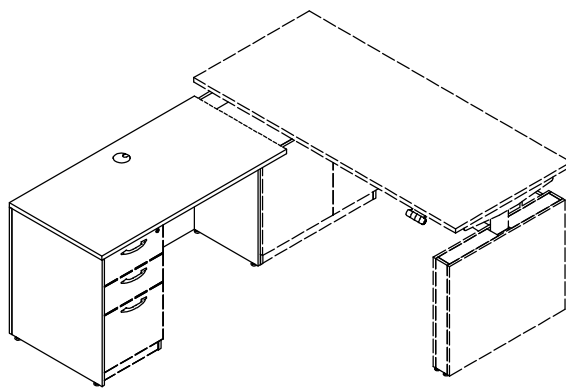
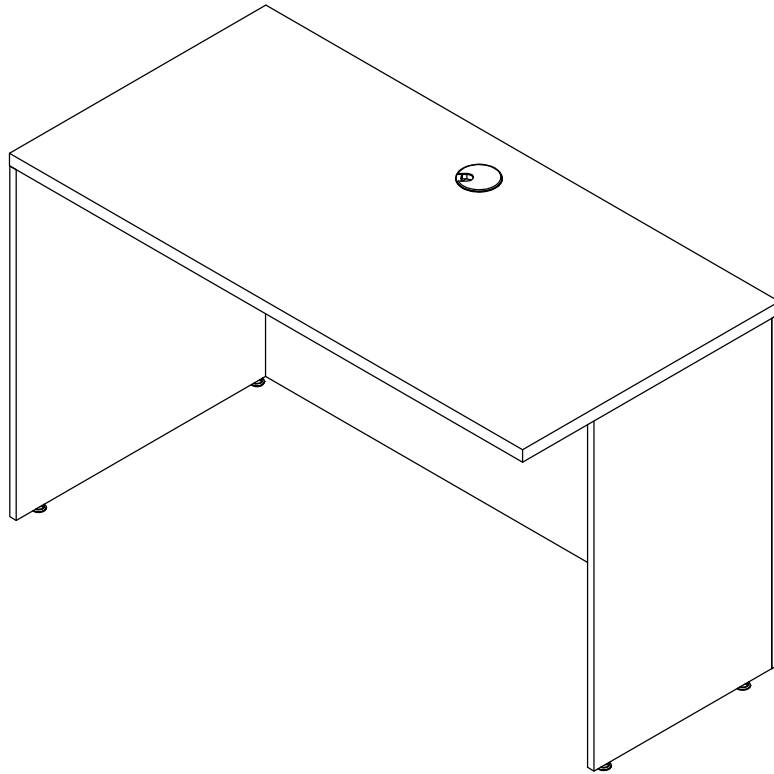

People Required for Assembly

Dear Customer,

Thank you for choosing us. Before you begin assembly, check that you have all the parts and hardware shown on this page.

If there is any item missing, please mark the item, indicating quantity required and send picture to us. We will arrange replacement at first time.

If feel question in assemble, Please feel free to ask us.

Customer satisfaction is our prime.

Your order means a lot to us!

Thank you

TOOLS NEEDED

Crosshead screwdriver
Flat-head screwdriver

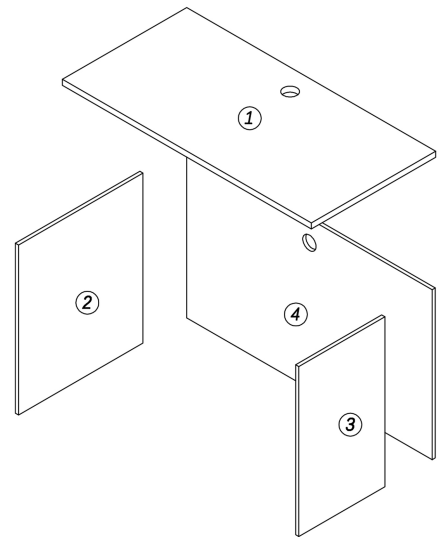

HARDWARE

A: Cam lock
Φ 15mm



13 pcs

B: Cam bolt
M6



13 pcs

C: Wooden Dowel
Φ 8*30mm



10 pcs

D: Glider
M6*25mm



4 pcs

E: Plug(low)
Φ 15mm



13 pcs

F: Grommet
Φ 64mm



2 pcs

STEP 1

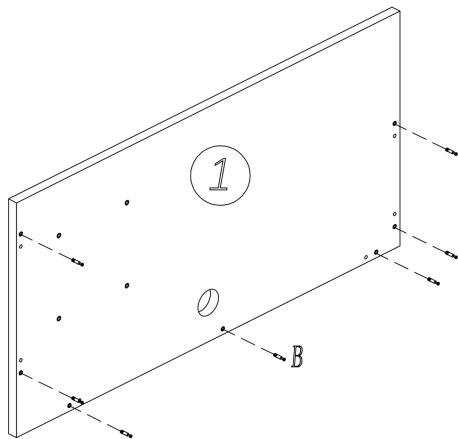

B  7 pcs

STEP 2

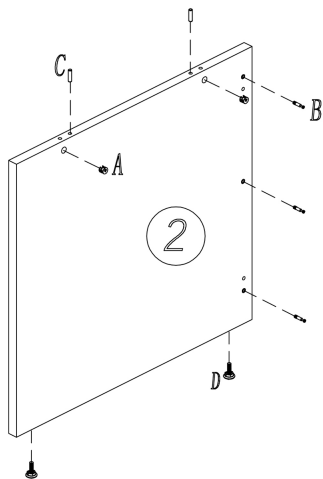

A  2 pcs

C  2 pcs

B  3 pcs

D  2 pcs

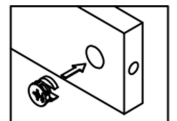

Direction of arrow to the side hole.

STEP 3

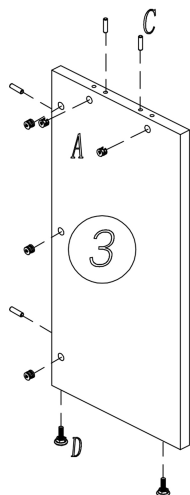

A  5 pcs

C  4 pcs

D  2 pcs

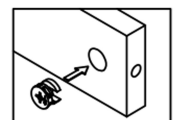

Direction of arrow to the side hole.

STEP 4

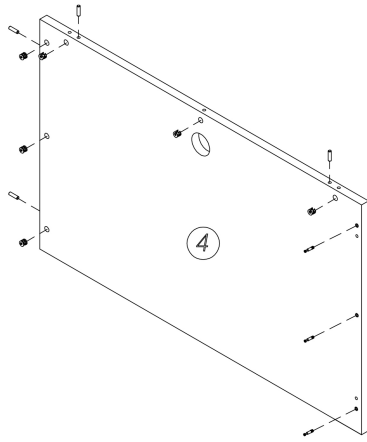

A  6 pcs

B  3 pcs

C  4 pcs

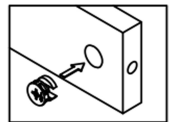

Direction of arrow to the side hole.

STEP 5

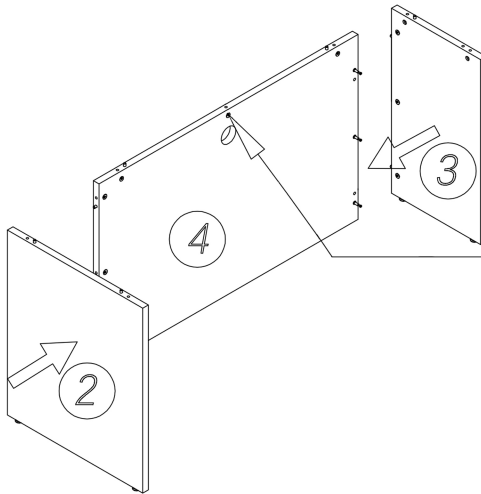

Note:

pay attention to the position of holes;

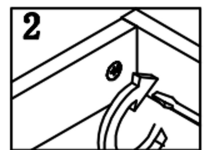
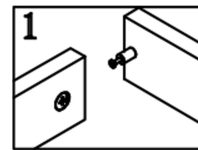

STEP 6

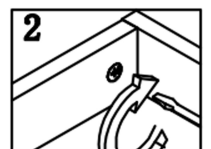
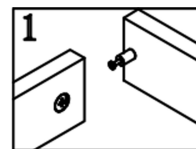
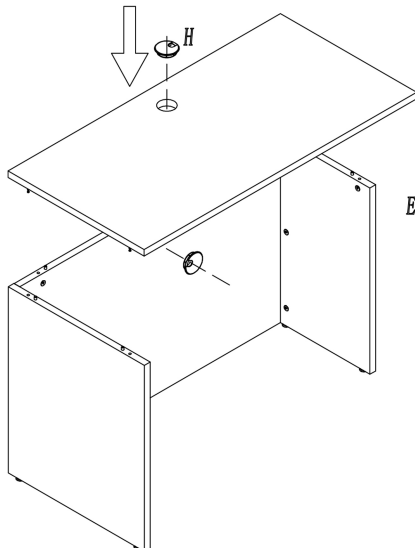

STEP 7

Schematic diagram - Used with other products

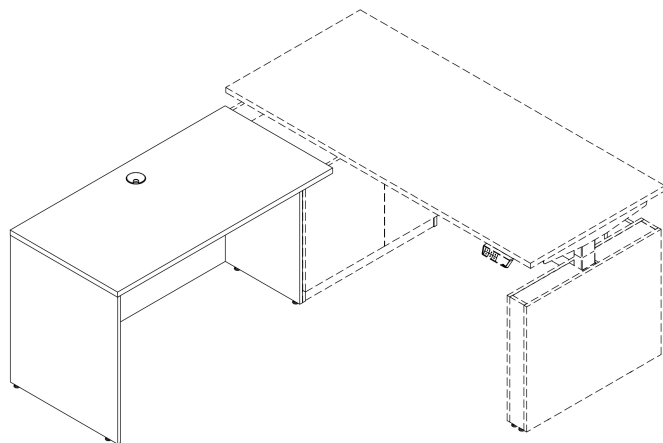

Thank you for your recent order.

We strive to provide customers with great services and satisfaction.

If any questions, please contact us.

Our customer support team is ready to help!

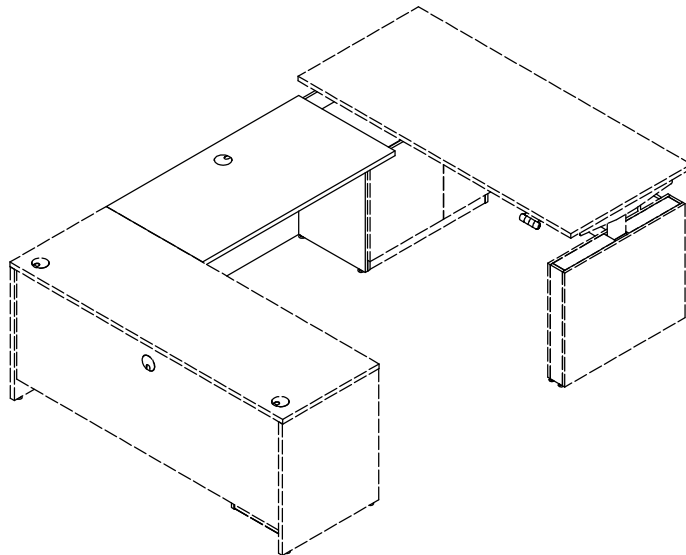
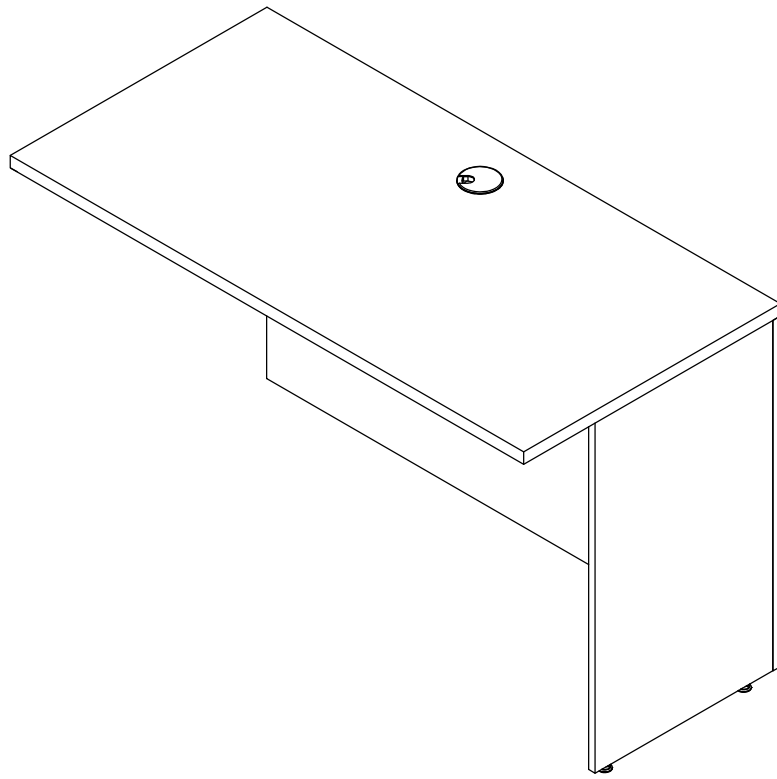

People Required for Assembly

Dear Customer,

Thank you for choosing us. Before you begin assembly, check that you have all the parts and hardware shown on this page.

If there is any item missing, please mark the item, indicating quantity required and send picture to us. We will arrange replacement at first time.

If feel question in assemble, Please feel free to ask us.

Customer satisfaction is our prime.

Your order means a lot to us!

Thank you

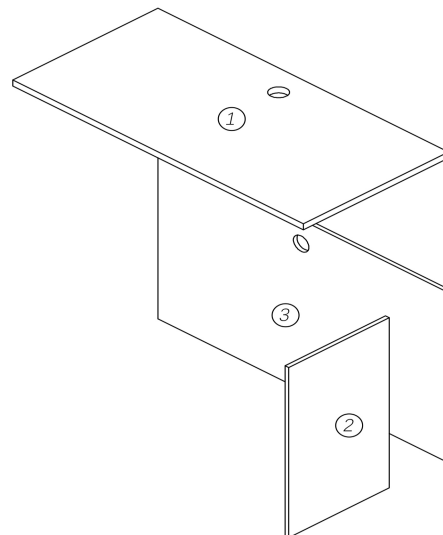

TOOLS NEEDED

Crosshead screwdriver
Flat-head screwdriver



HARDWARE

A: Cam lock
Φ 15mm



8 pcs

B: Cam bolt
M6



8 pcs

C: Wooden Dowel
Φ 8*30mm



6 pcs

D: Glider
M6*25mm



4 pcs

E: Plug(low)
Φ 15mm



8 pcs

F: Grommet
Φ 64mm



2 pcs

G: Plane connector
67*38mm



2 pcs

H: Countersunk screw
M4*16mm



8 pcs

STEP 1

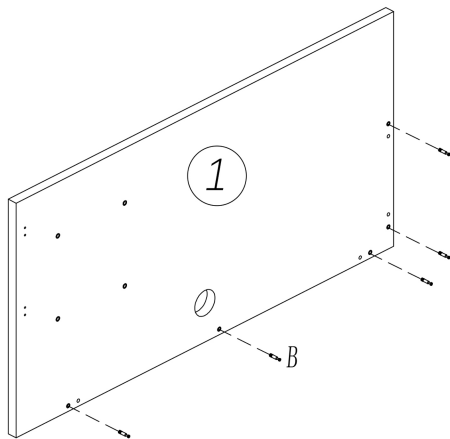

B  5 pcs

STEP 2

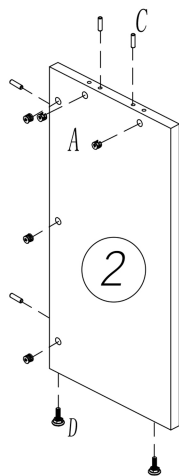

A  5 pcs

C  4 pcs

D  2 pcs

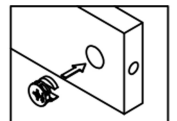

Direction of arrow to the side hole.

STEP 3

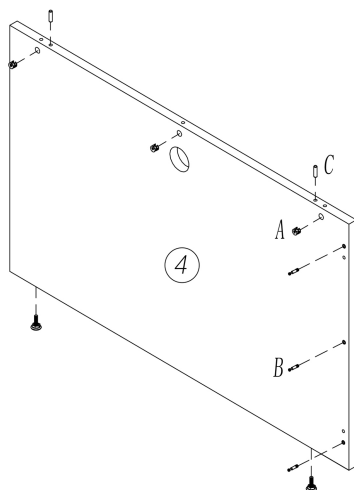

A  3 pcs

B  3 pcs

C  2 pcs

D  2 pcs

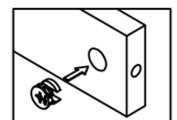

Direction of arrow to the side hole.

STEP 4

Note:

Please note that the side with this hole faces inward

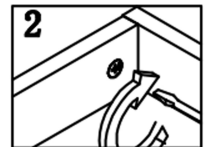
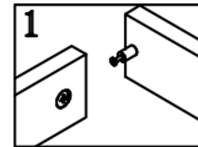
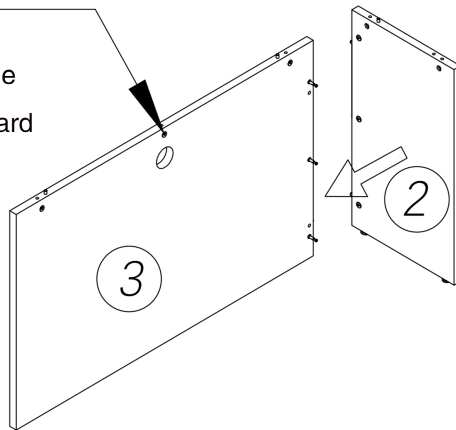

STEP 5

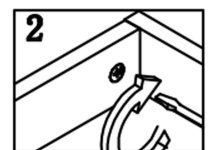
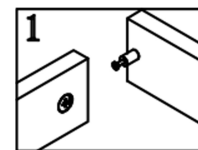
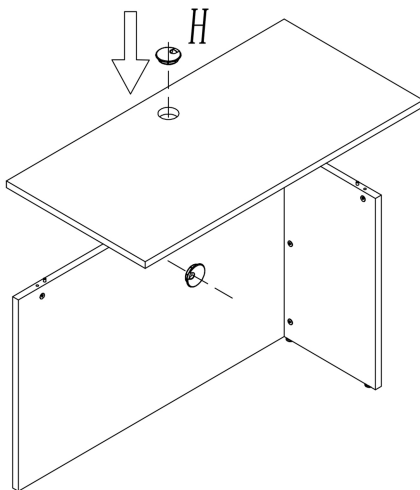

STEP 6

Schematic diagram - Used with other products

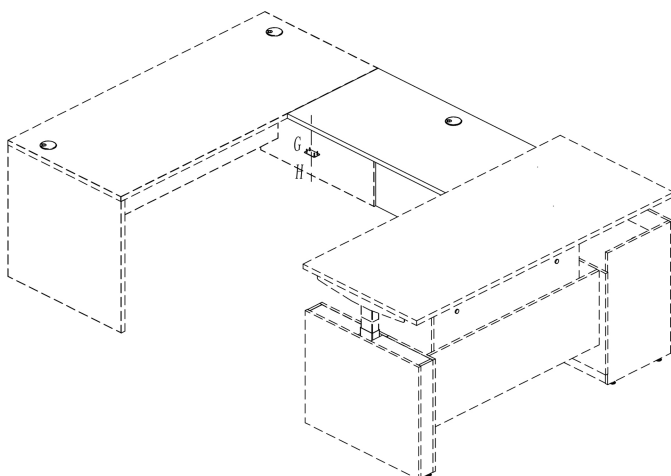

Thank you for your recent order.
We strive to provide customers with great services and satisfaction.
If any questions, please contact us.
Our customer support team is ready to help!