

# Assembly Instruction

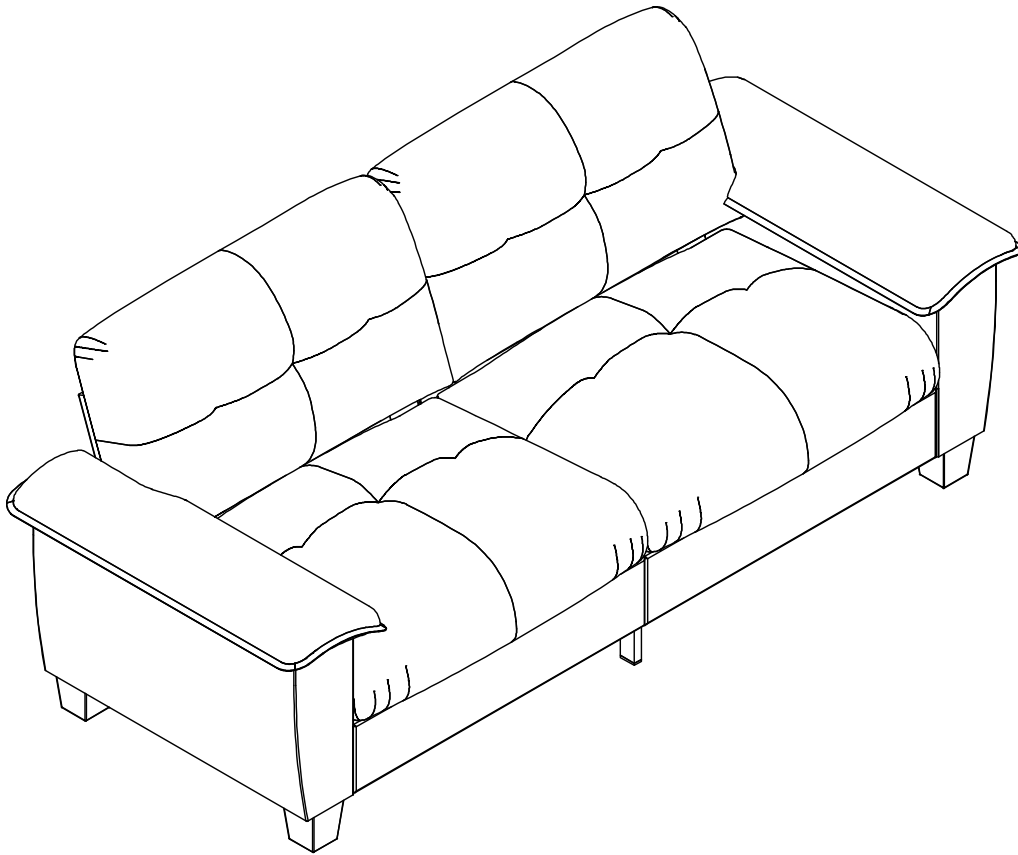

## PARTS

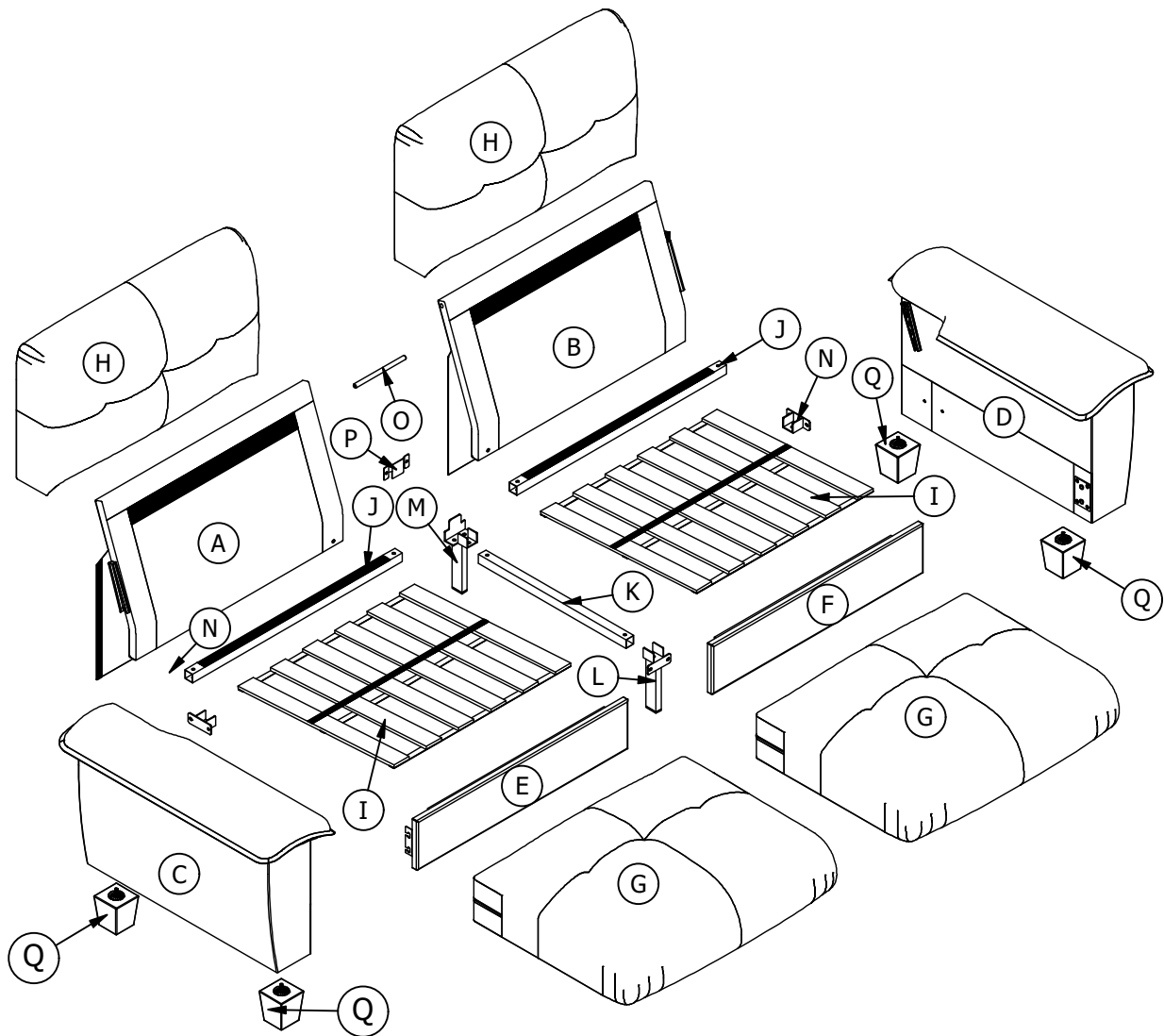

# PARTS LIST

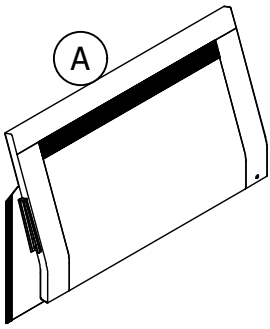

Left Back Frame  
X 1 PC

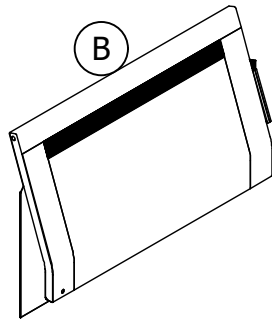

Right Back Frame  
X 1 PC

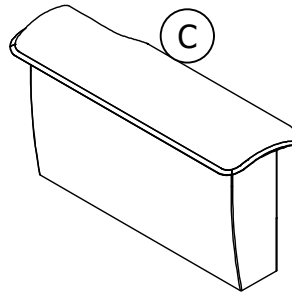

Left Armrest  
X 1 PC

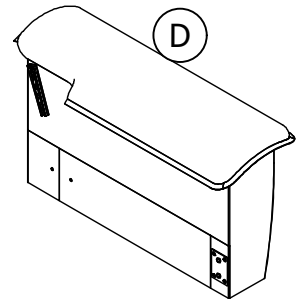

Right Armrest  
X 1 PC

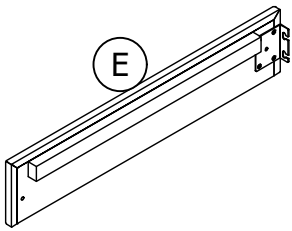

Left Front Rail  
X 1 PC

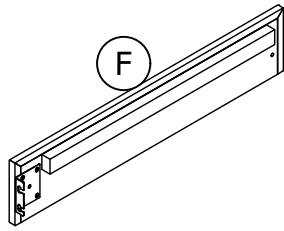

Right Front Rail  
X 1 PC

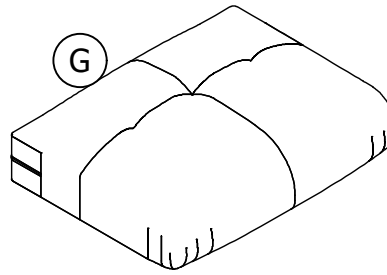

Seat Cushion  
X 2 PCS

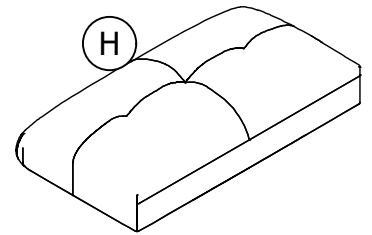

Back Cushion  
X 2 PCS

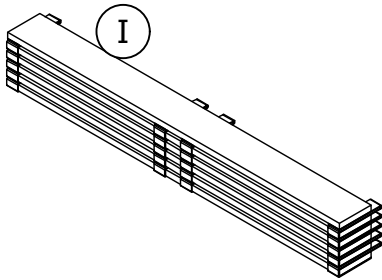

Seat Panel  
X 2 PCS

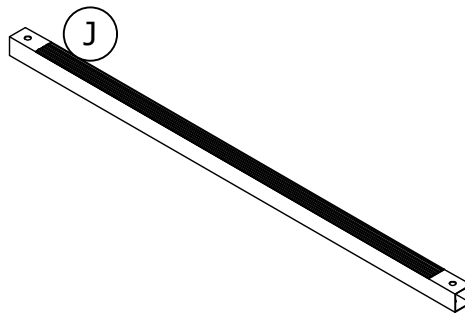

Rear Rail  
X 2 PCS

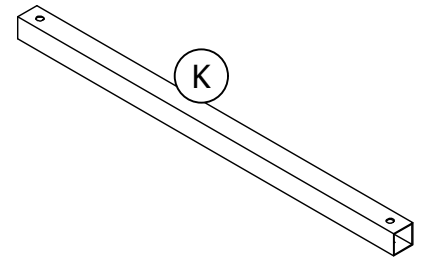

Middle Connector  
X 1 PC

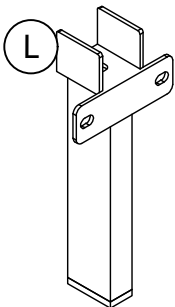

Front Middle Leg  
X 1 PC

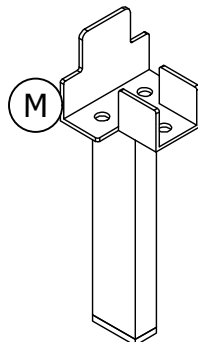

Rear Middle Leg  
X 1 PC

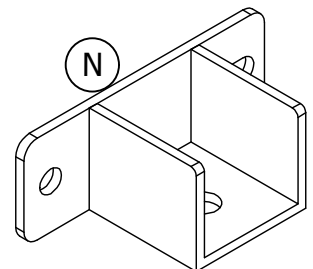

Bracket  
X 2 PCS

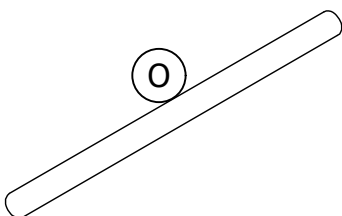

Connector  
X 1 PC

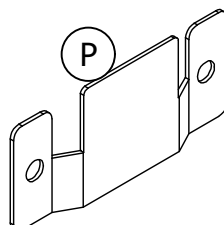

Plug-in  
X 1 PC

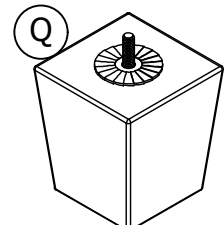

Leg  
X 4 PCS

# HARDWARE

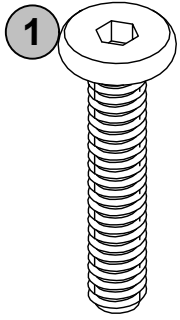

5/16" X 40mm Bolt  
X 6

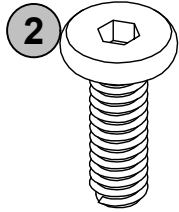

5/16" X 23mm Bolt  
X 2

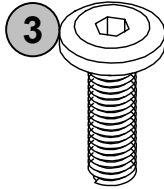

1/4" X 20mm Bolt  
X 6

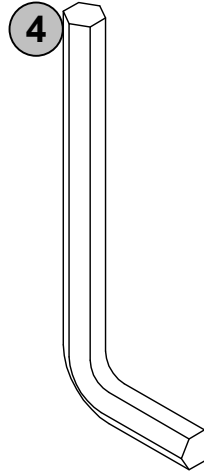

5mm Allen Key  
X 1

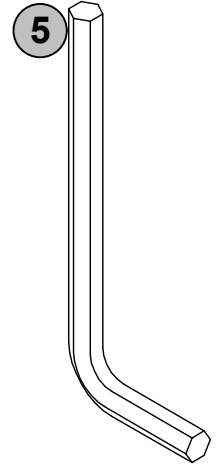

4mm Allen Key  
X 1

## STEP 1:

Some parts will be found in the compartment under the Armrests, as shown.

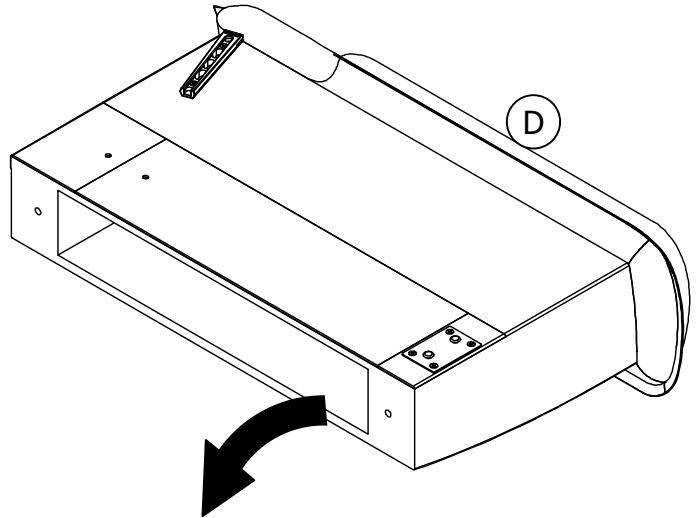
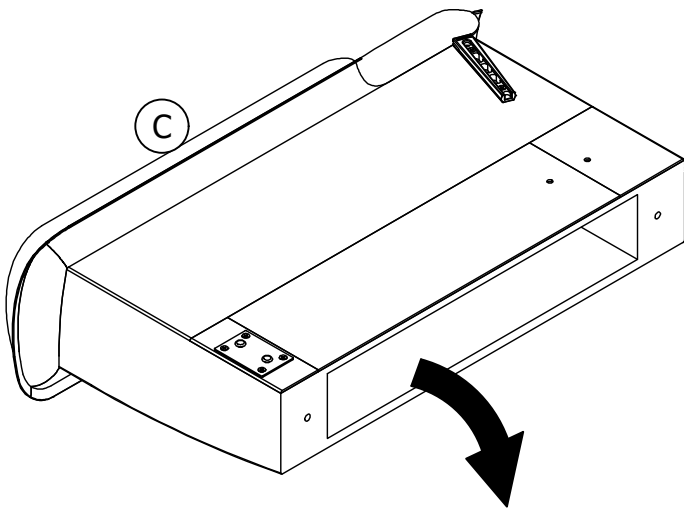

**STEP 2:**

Attach Bracket **N** x 2 to Armrest **C** & **D** with bolts **3**, as shown.

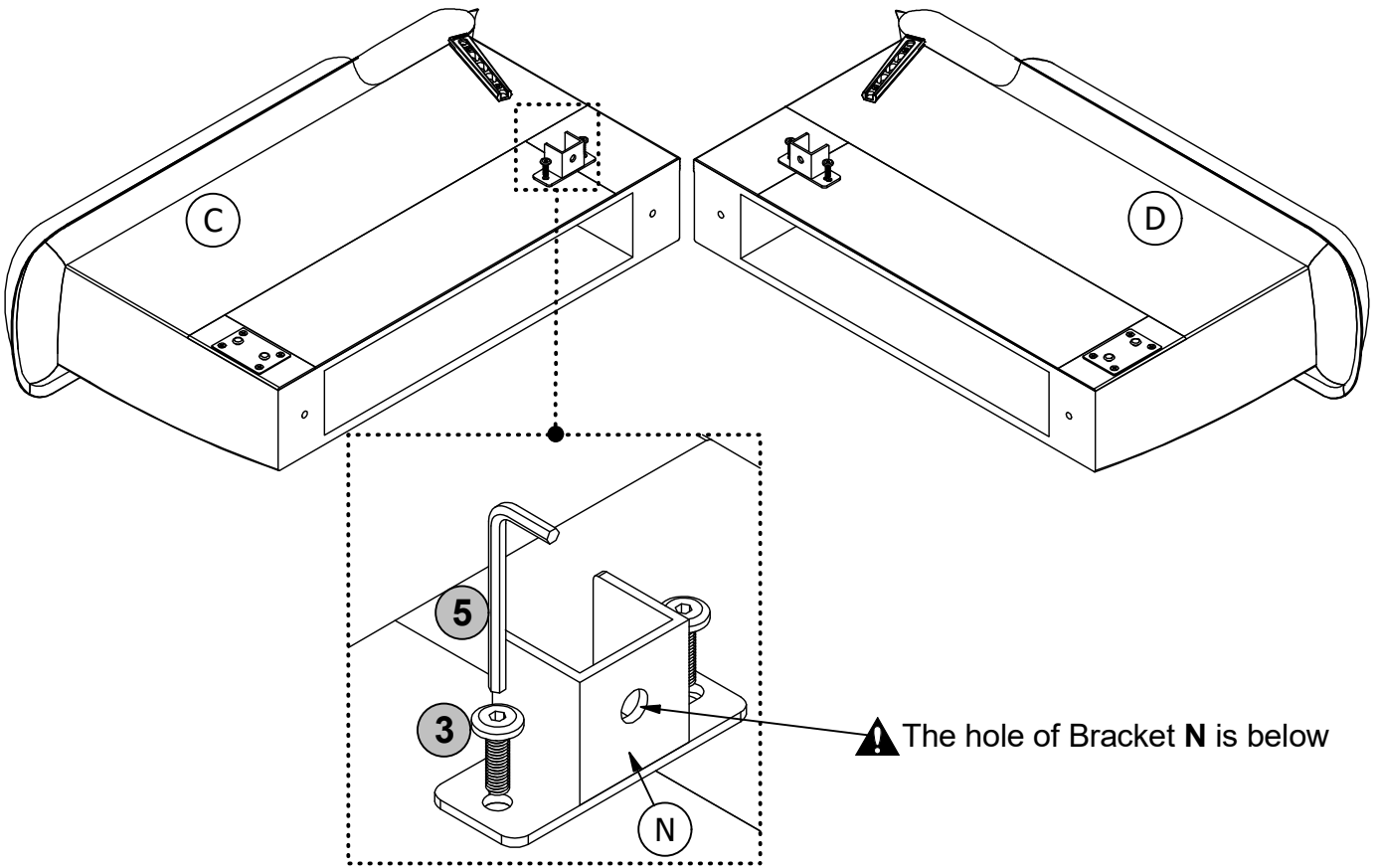

**STEP 3:**

Manually screw **Q** x 4 to Armrest **C** & **D**, as shown.

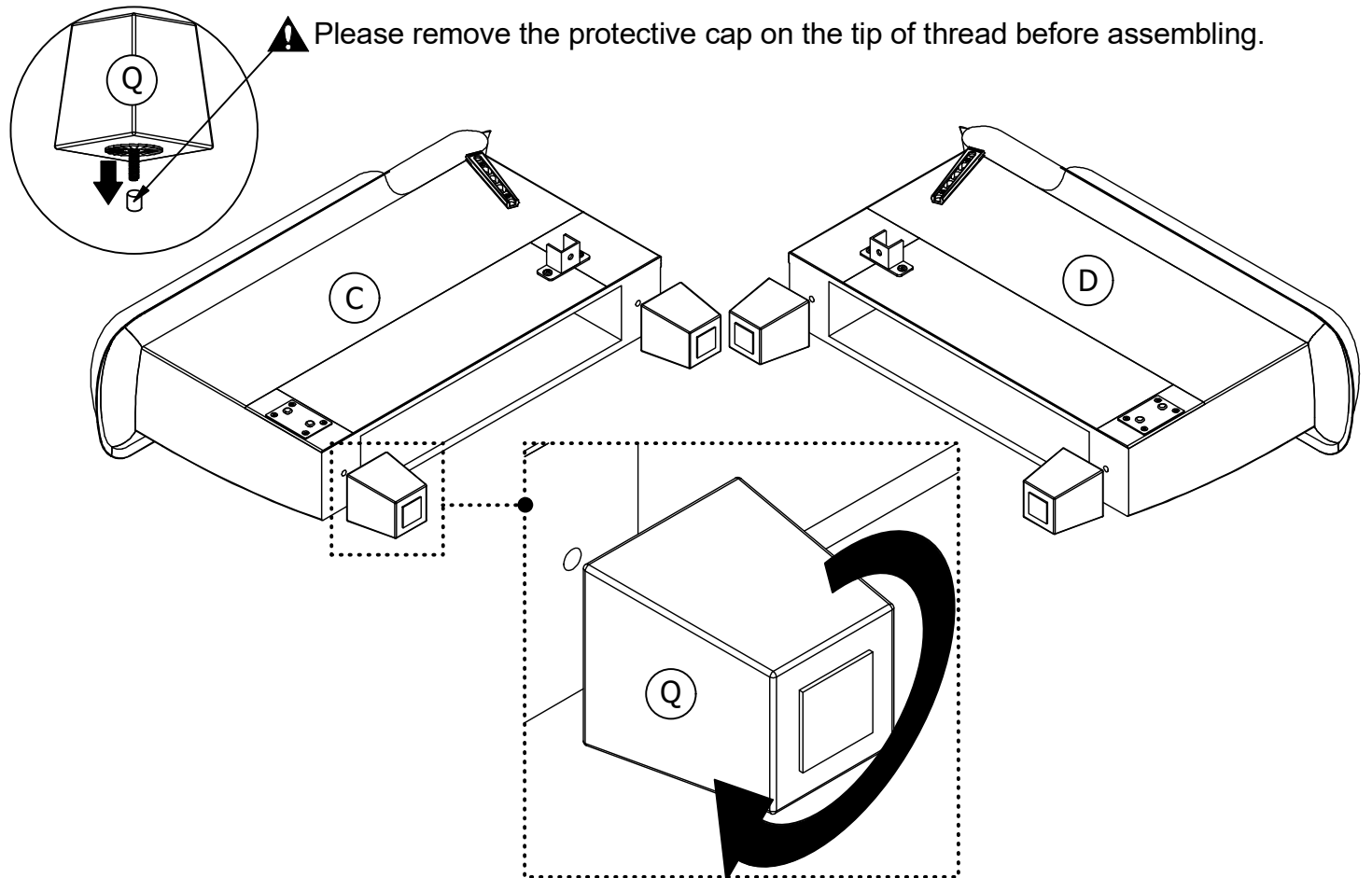

**STEP 4:**

Attach Front Middle Leg **L** to Front Rail **E** & **F** with bolts **3**, as shown.

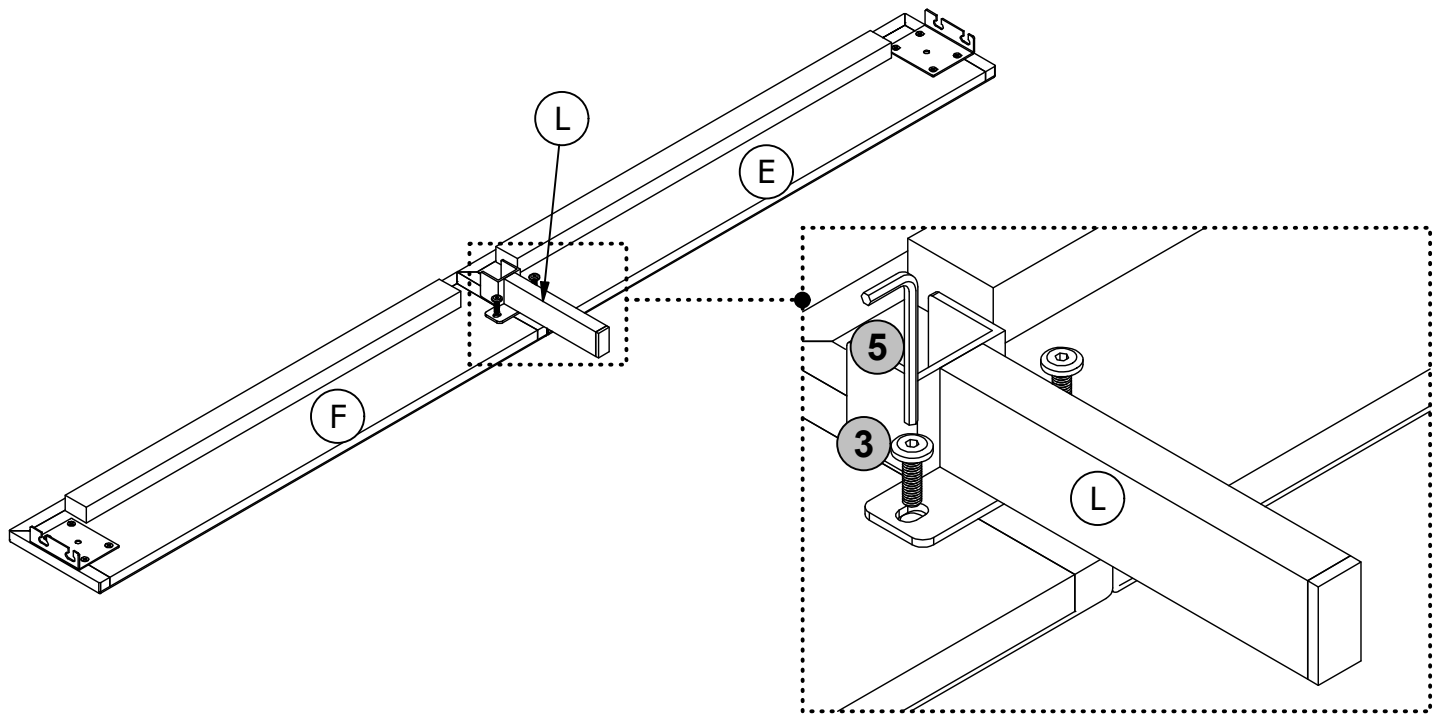

**STEP 5:**

Attach Front Rail **E** & **F** to Armrests **C** & **D** by inserting the brackets on Front Rail **E** & **F** into the metal plate on Armrests **C** & **D**, as shown.

Push Front Rail **E** & **F** with a downward force to secure it into place.

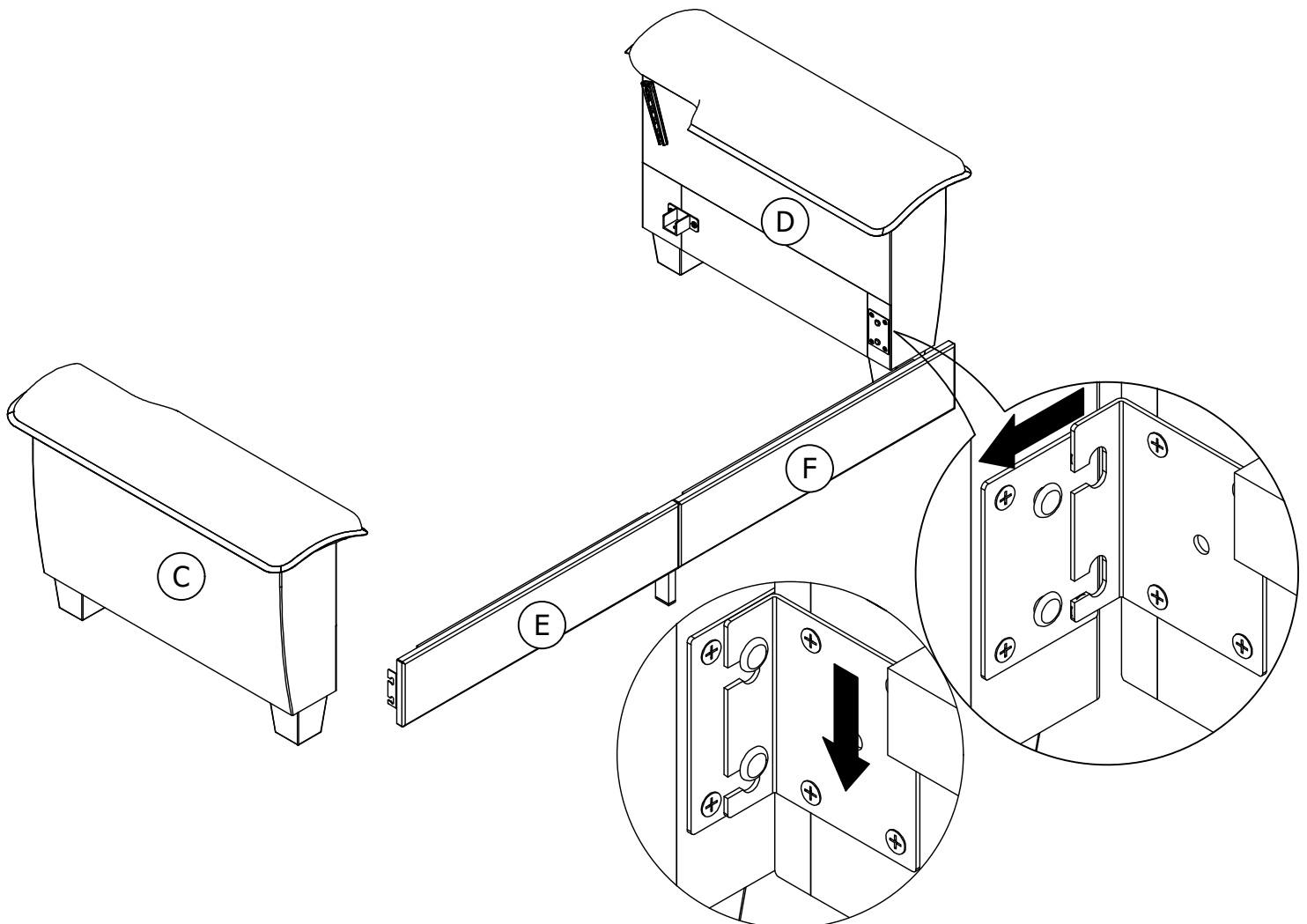

**STEP 6:**

Attach Rear Rail **J** x 2 to Bracket **N** x 2 & Rear Middle Leg **M**.

6.1 Attach Rear Rail **J** x 2 to Rear Middle Leg **M** with bolts **1**.

6.2 Attach Rear Rail **J** x 2 to Bracket **N** x 2 with bolts **1**, as shown.

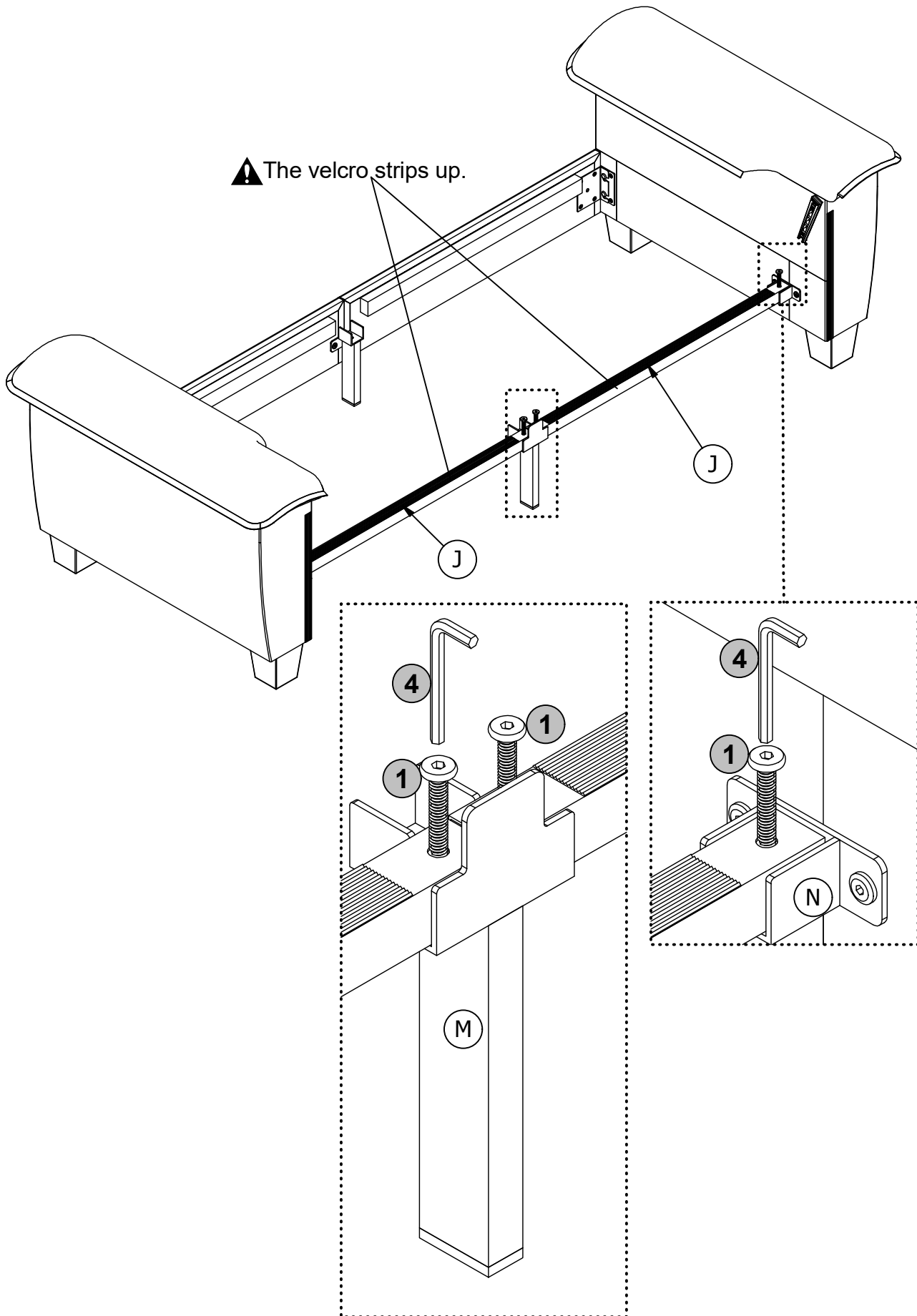

**STEP 7:**

Attach Middle Connector **K** to Front Middle Leg **L** & Rear Middle Leg **M** with bolts **1**, as shown.

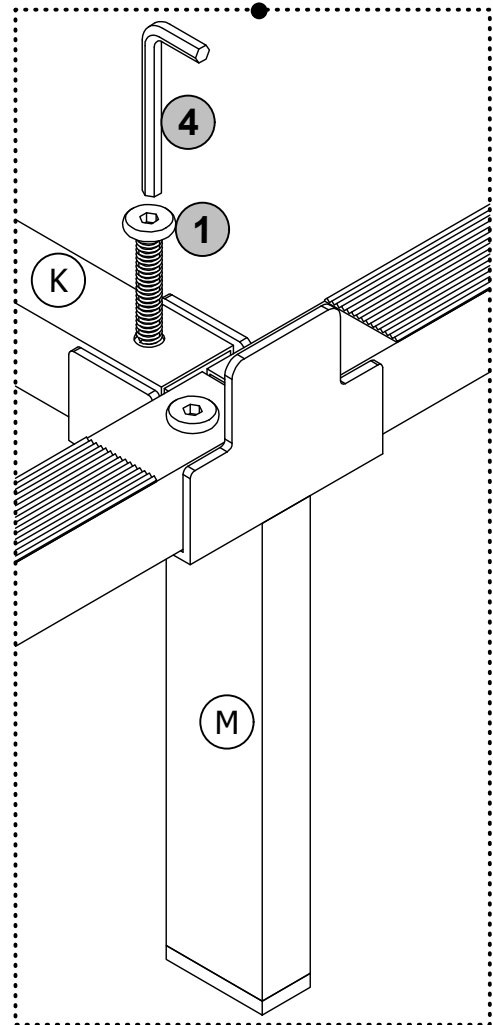
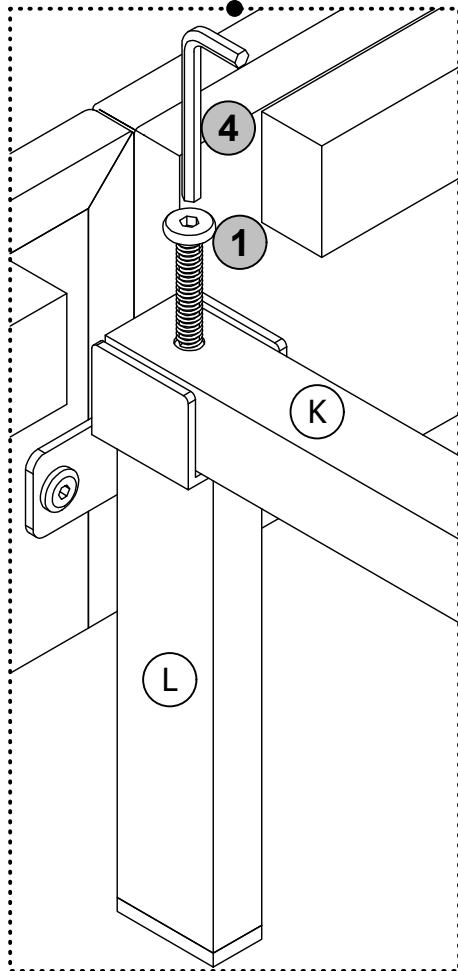
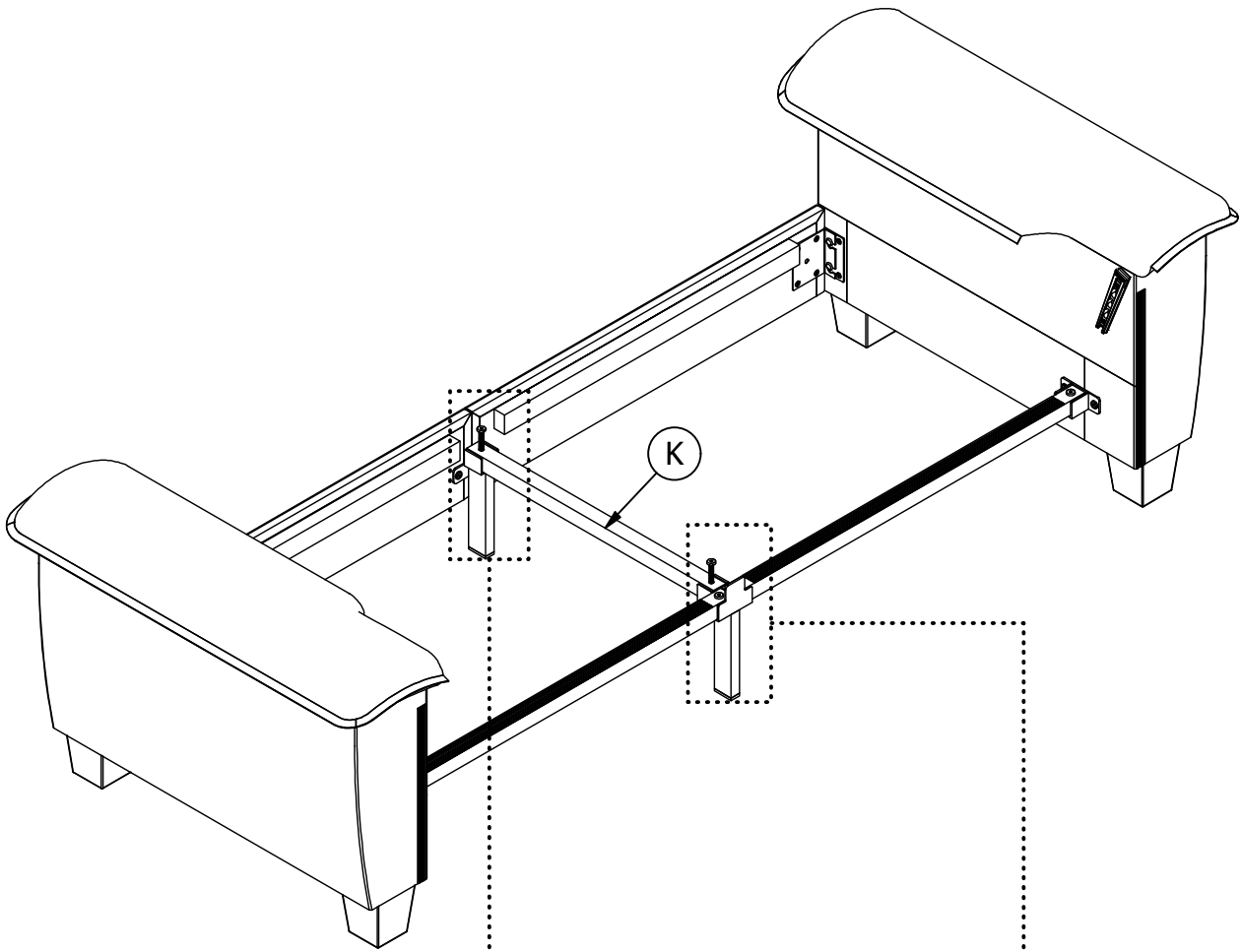

**STEP 8:**

Connect Back Frame **A** & **B** using Connector **O**, as shown.

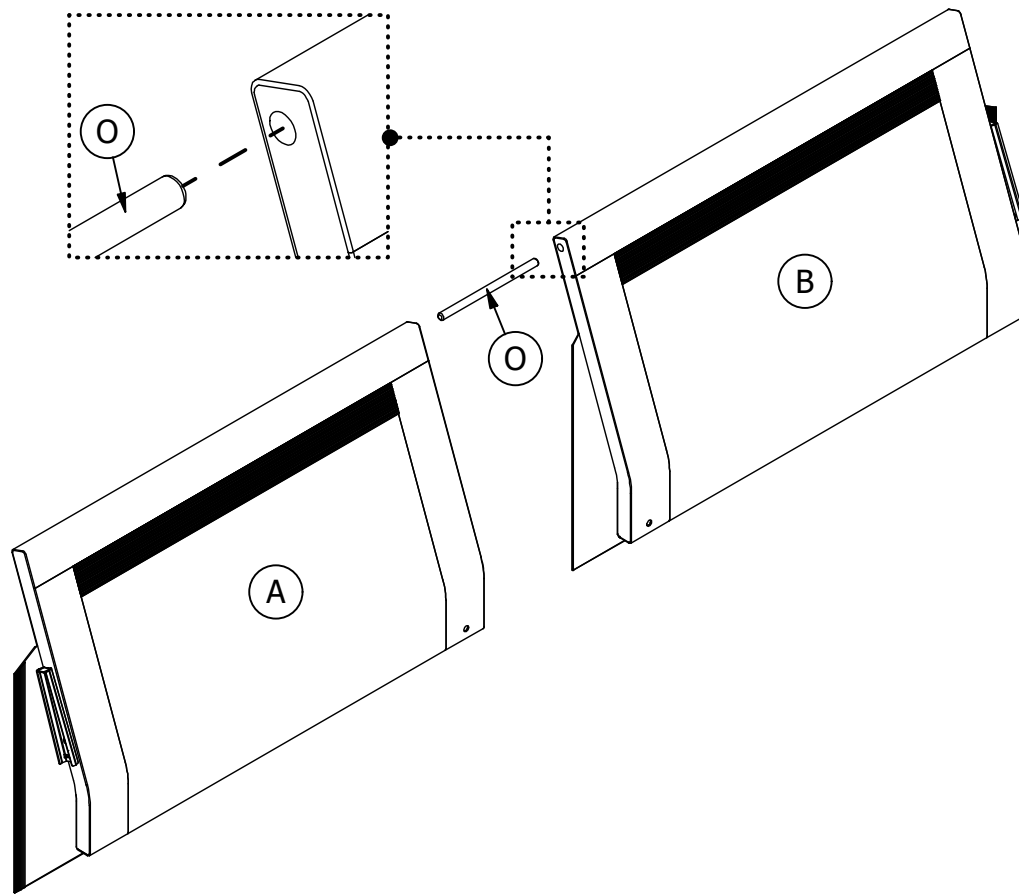

**STEP 9:**

Attach Plug-in **P** to Back Frame **A** & **B** with bolt **2**, as shown.

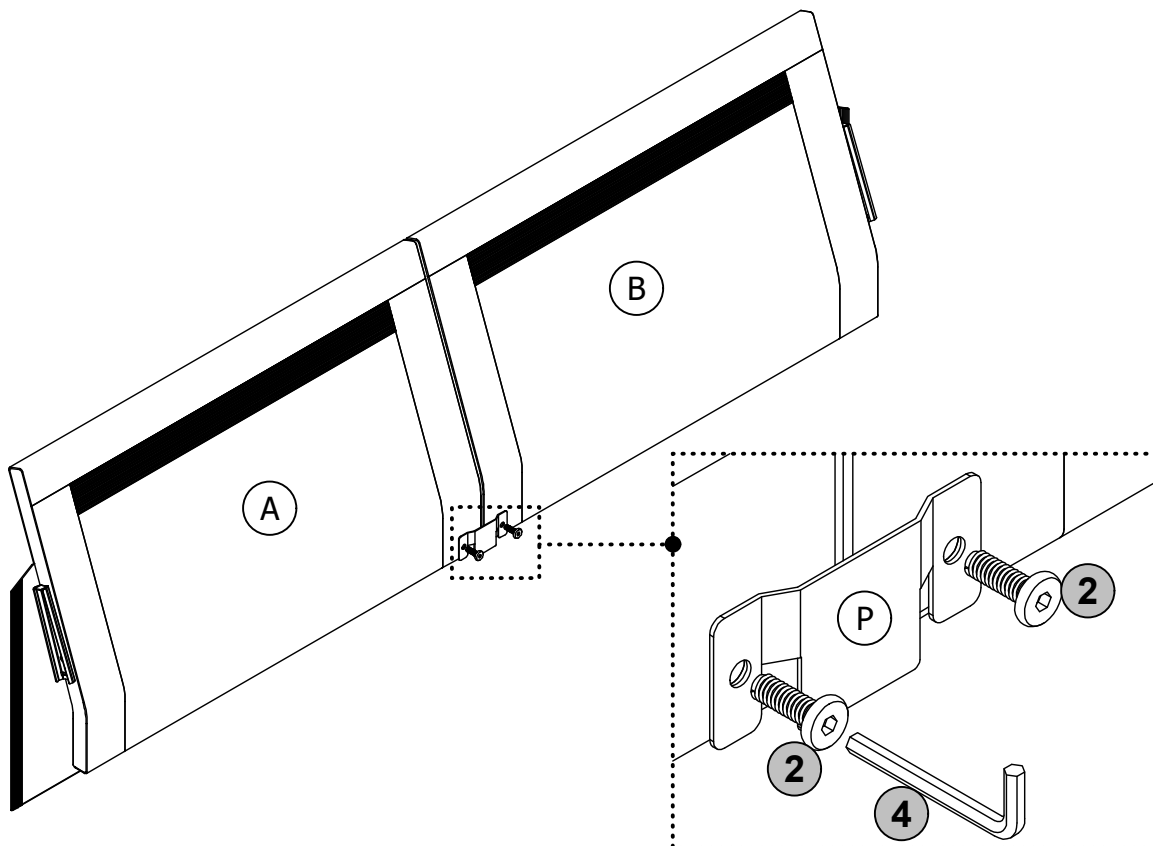

**STEP 10:**

Attach Back Frame **A** & **B** to Armrest **C** & **D** by inserting the brackets on Back Frame **A** & **B** to the metal glides on Armrest **C** & **D**.

Attach Back Frame **A** & **B** to Rear Middle Leg **M** by inserting the Plug-in **P** on Back Frame **A** & **B** to Rear Middle Leg **M**.

Push Back Frame **A** & **B** downwards to secure it into place.

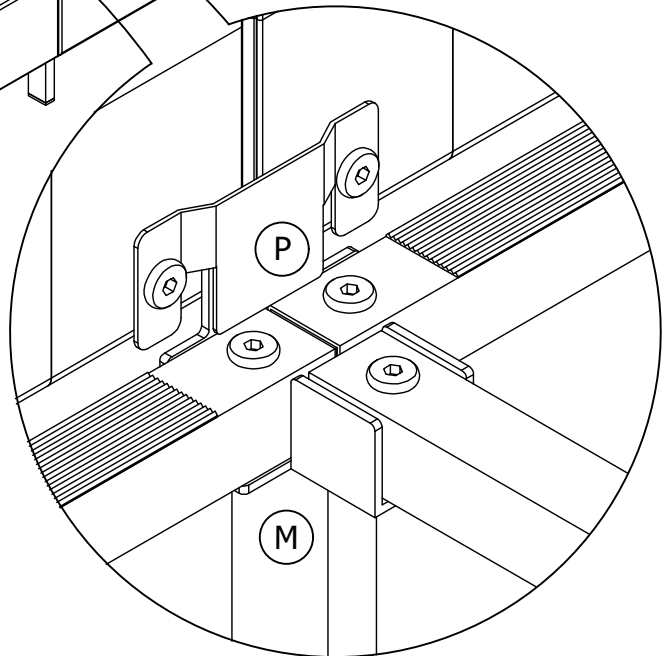
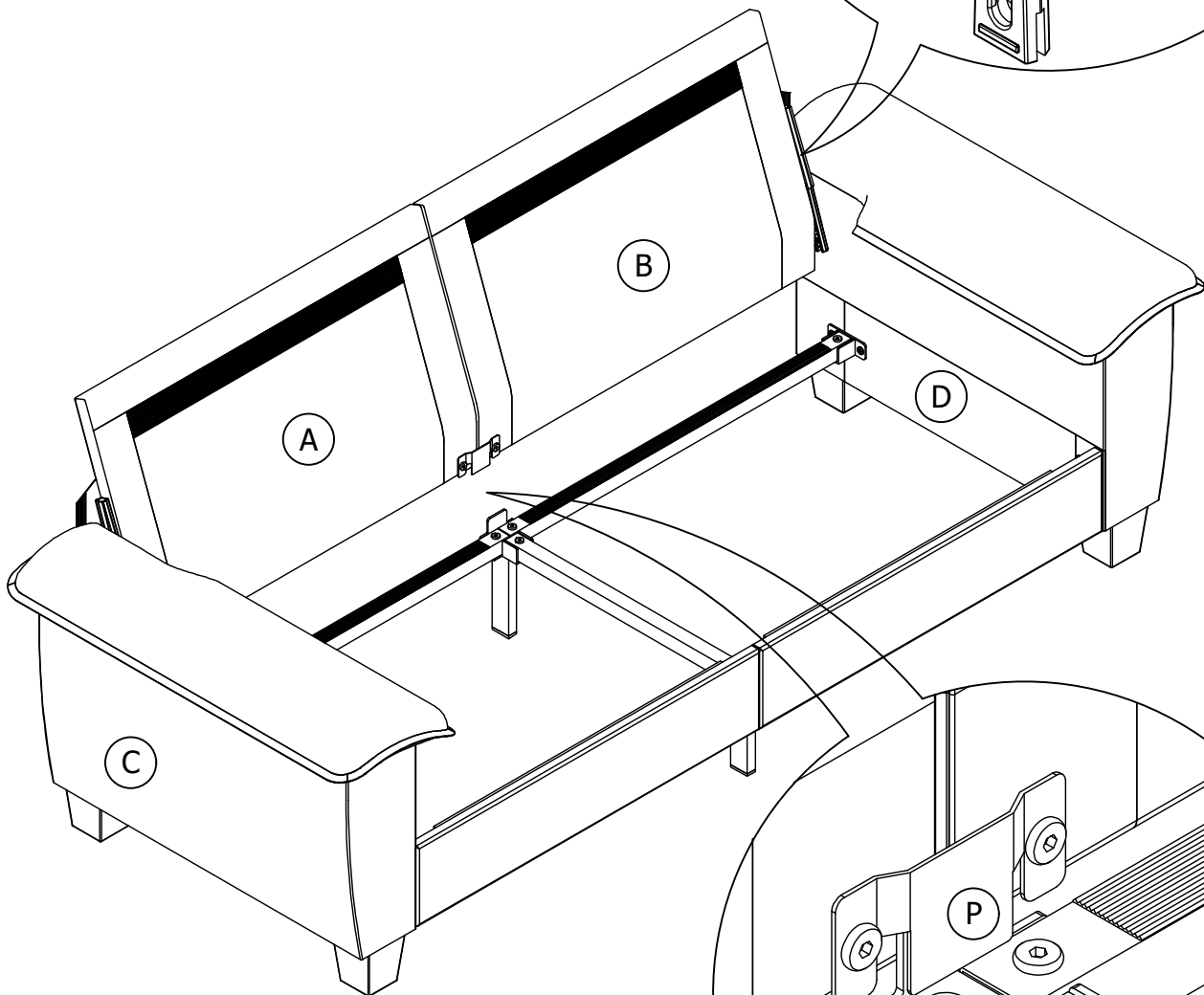
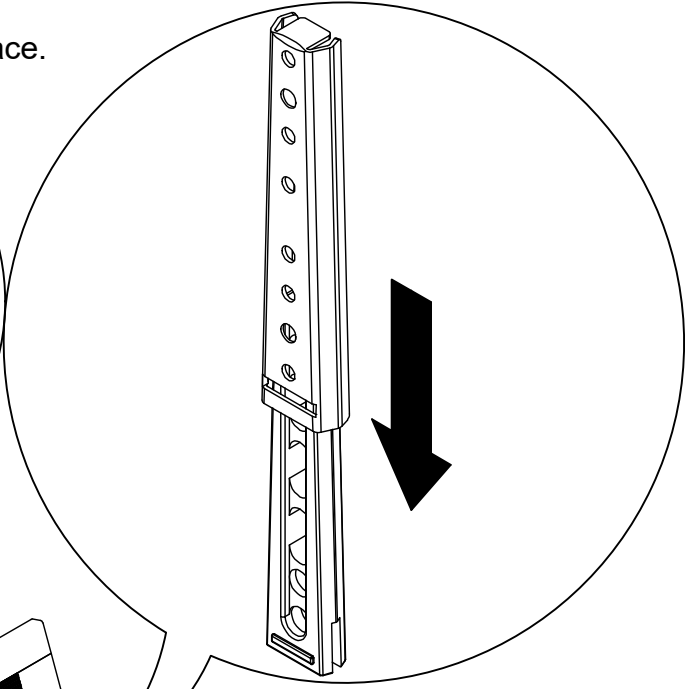
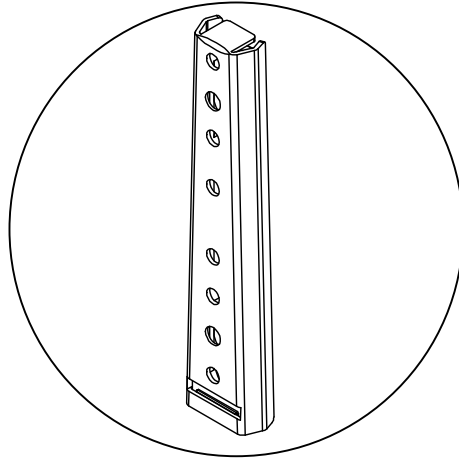

**STEP 11:**

Stick fabric cover on Back Frame **A** & **B** to Armrests **C** & **D** with the velcro strips.

Stick fabric cover on Left Back Frame **A** to Right Back Frame **B** with the velcro strips, as shown.

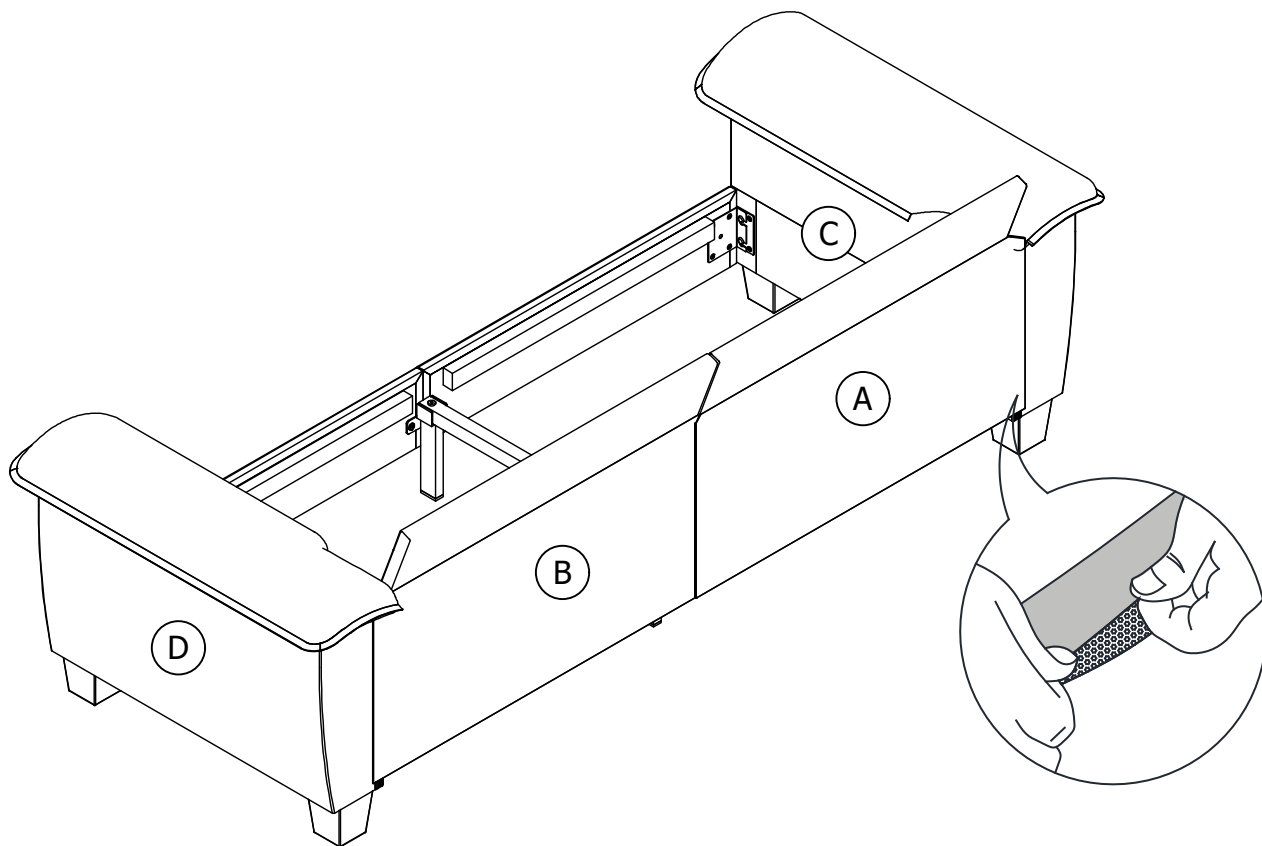

**STEP 12:**

Unfold Seat Panel **I** x 2.

Place Seat Panel **I** x 2 onto the seat using the Velcro strips.

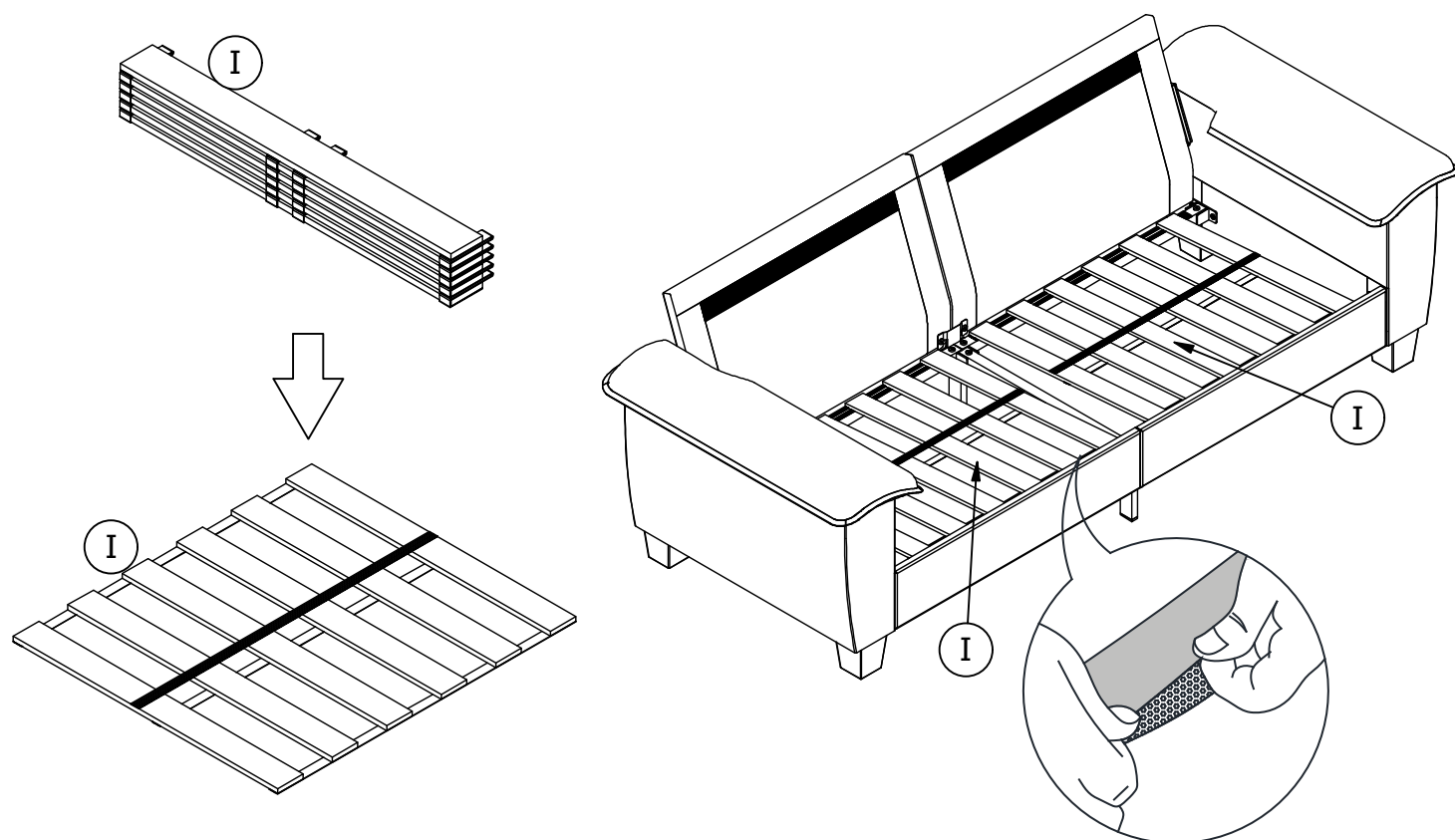

**STEP 13:**

13.1 Remove the Cushion **G** x 2 & **H** x 2 from their vacuum sealed package.

13.2 Place the Cushion **G** x 2 & **H** x 2 onto the sofa using the velcro strips.

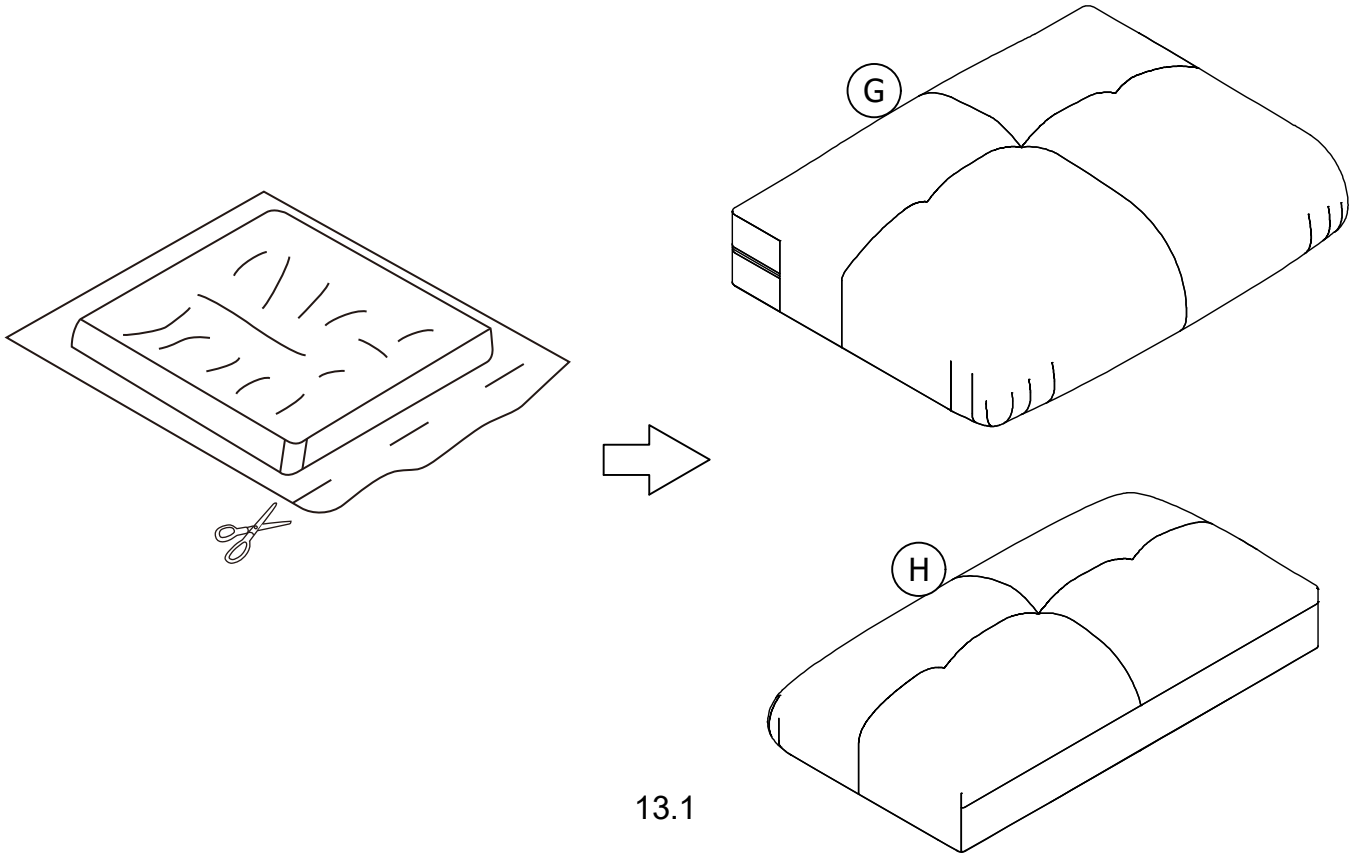

13.1

**Note:** The cushions have been vacuum packed for transportation purposes. After unpacking, please allow up to 72 hours so that it can return to its original shape.

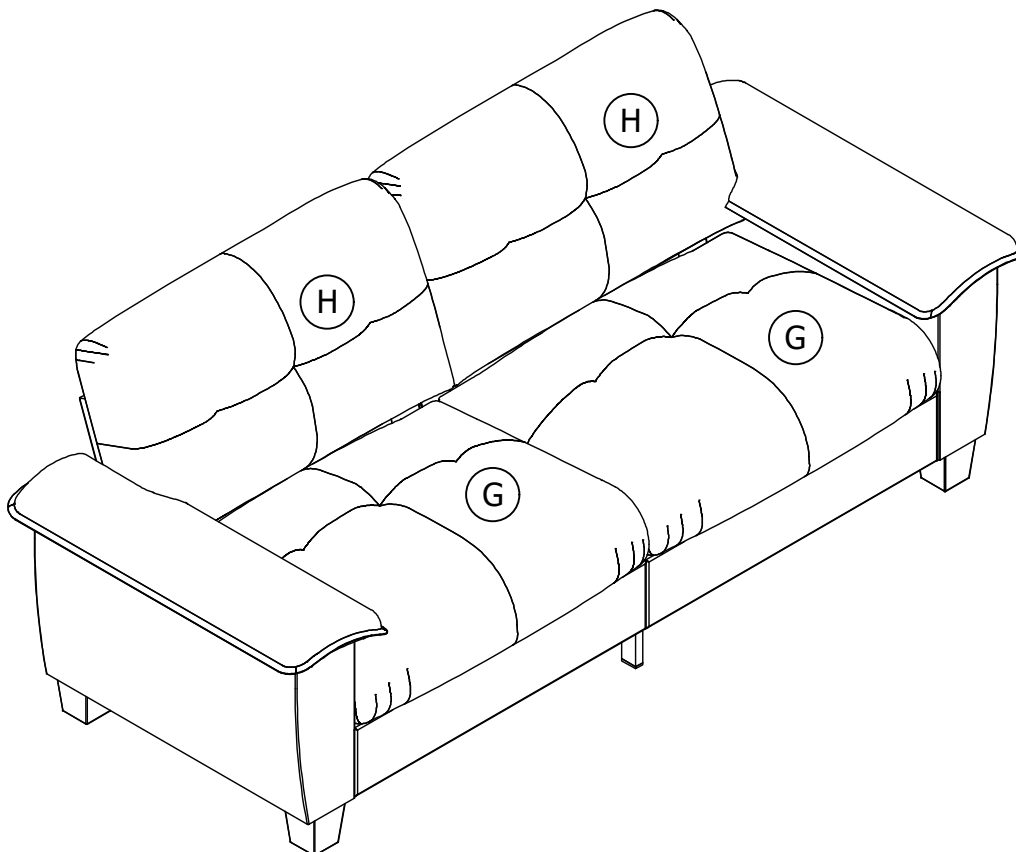

13.2

# Helpful Hints

- Your futon can transform between a Sofa and a Bed.
- Move your new furniture carefully, with two people lifting and carrying the unit to its new location.
- Your furniture can be disassembled and reassembled to move.
- Clean the product with a soft damp cloth. DO NOT use harsh chemicals or abrasive cleaners.
- For further information please contact at [sales4@jsanyee.com](mailto:sales4@jsanyee.com)

