

Outdoor Kitchen Shelves

SKU: LTFA5268

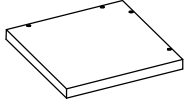

parts and components



① 1X

Aluminum Worktop



② 2X

Aluminum Legs

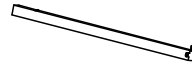

③ 2X

Aluminum Legs



④ 2X

Aluminum Shelf

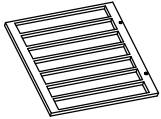

⑤ 1X

Aluminum Shelf

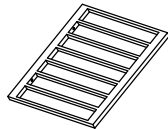

⑥ 1X

Aluminum Shelf

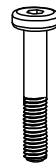

M6X55

⑦ 6X

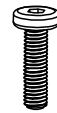

M6X18

⑧ 24X

Stainless Steel Washers



D6

⑨ 30X

Hex-L Key



⑩ 1X

Metal Bracket

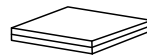

⑪ 1X

Protective Cover

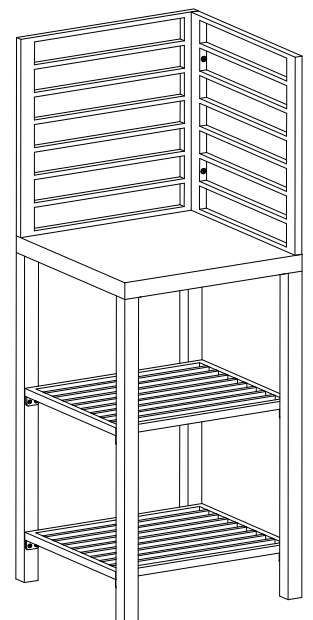

Step 1

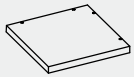

① 1X

Aluminum
Worktop

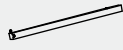

② 2X

Aluminum
Legs

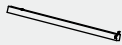

③ 2X

Aluminum
Legs



M6X18

⑦ 8X



⑧ 8X

Stainless Steel
Washers

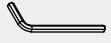

⑨ 1X

Hex-L Key

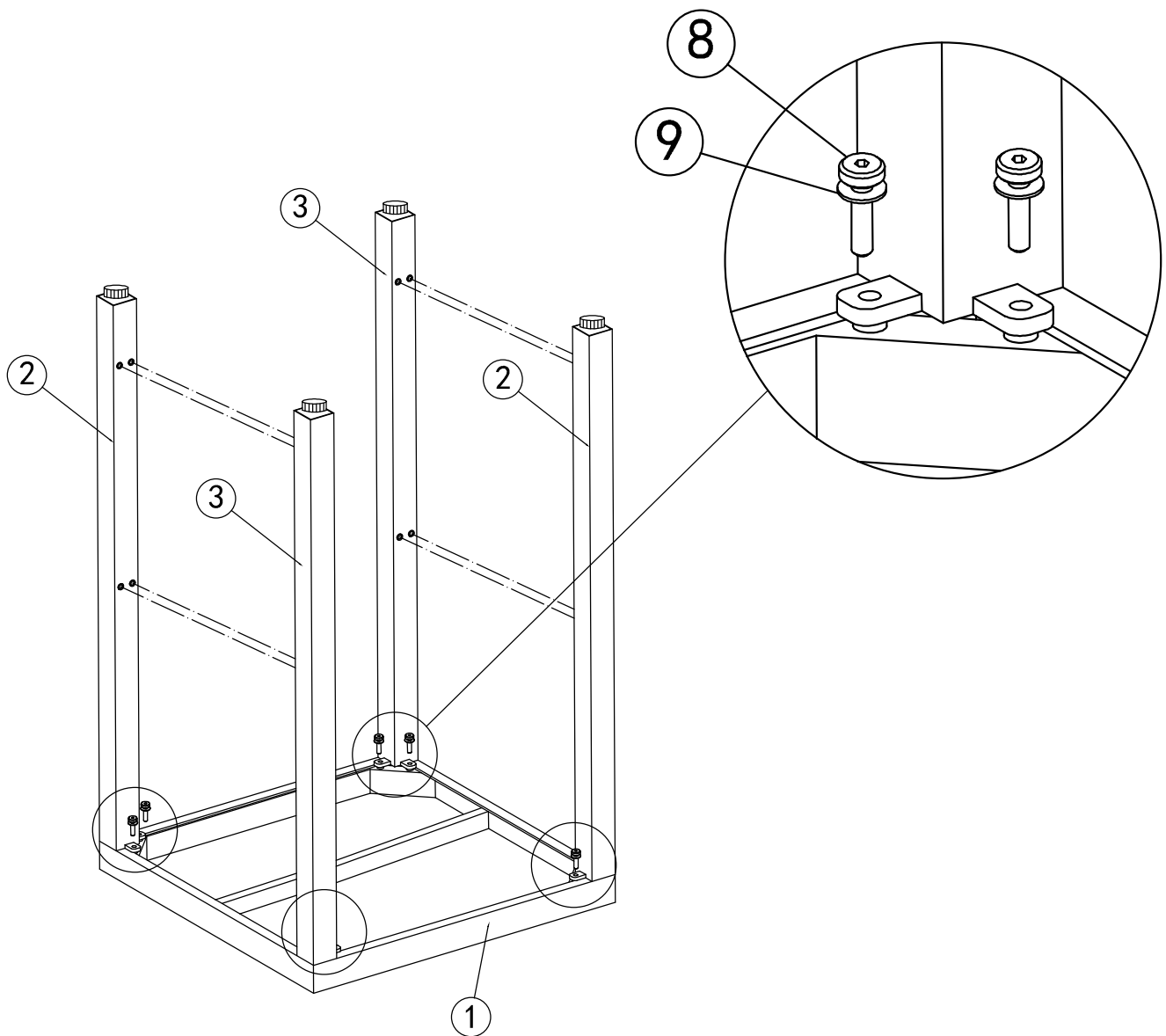

Step 2



④ 1X

Aluminum Shelf



⑦ 8X



⑧ 8X

Stainless Steel
Washers



⑨ 1X

Hex-L Key

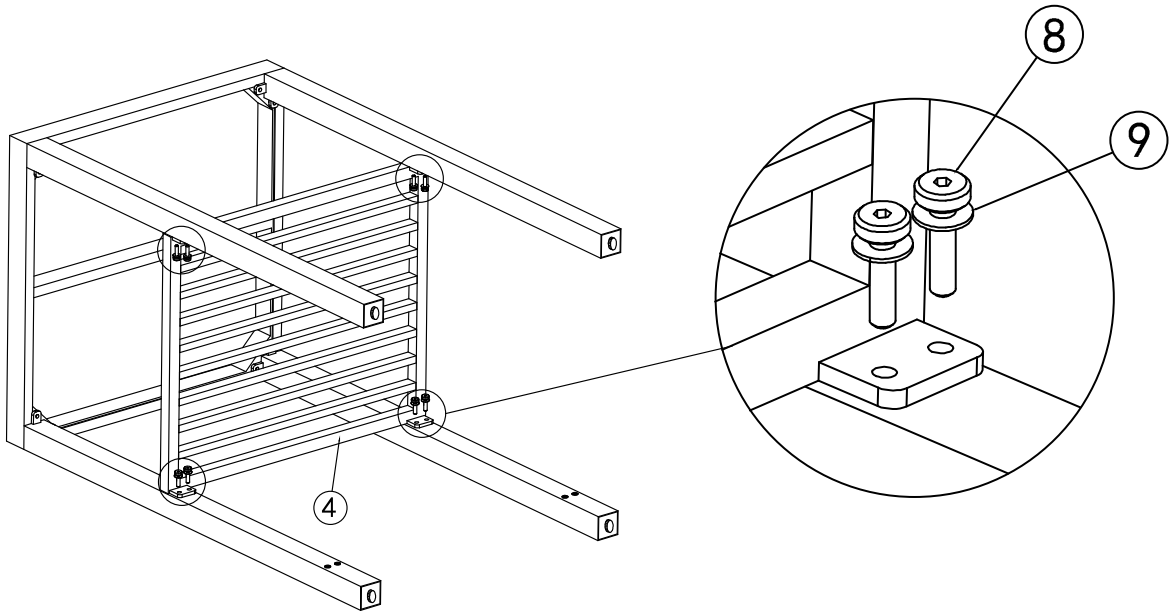

Step 3

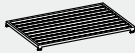

④ 1X

Aluminum Shelf



⑧ 8X



⑨ 8X

Stainless Steel
Washers



⑩ 1X

Hex-L Key

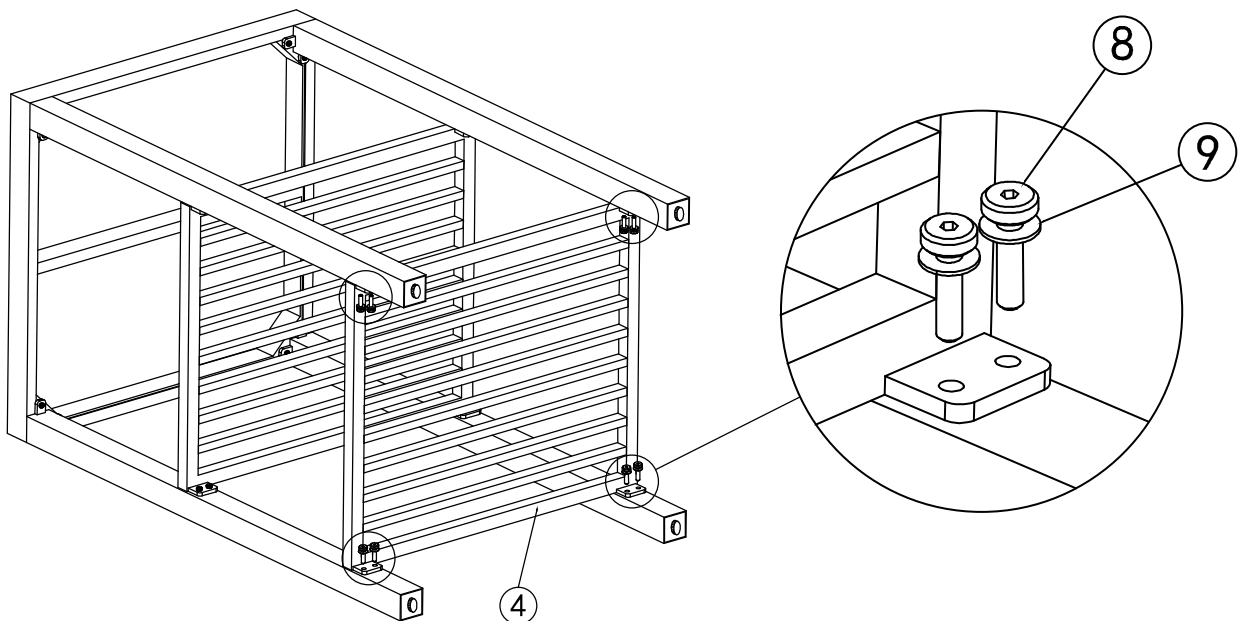

Step 4



⑤ 1X

Aluminum Shelf



M6X55

⑦ 2X



⑨ 2X

Stainless Steel Washers



⑩ 1X

Hex-L Key

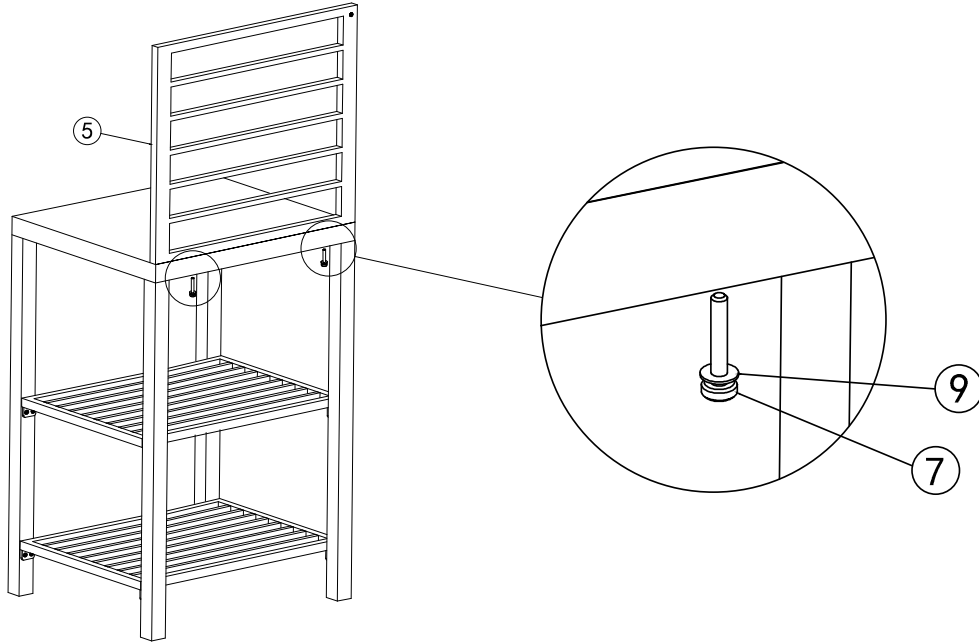

Step 5



⑥ 1X

Aluminum Shelf



M6X55

⑦ 2X



D6

⑨ 2X

Stainless Steel Washers



⑩ 1X

Hex-L Key

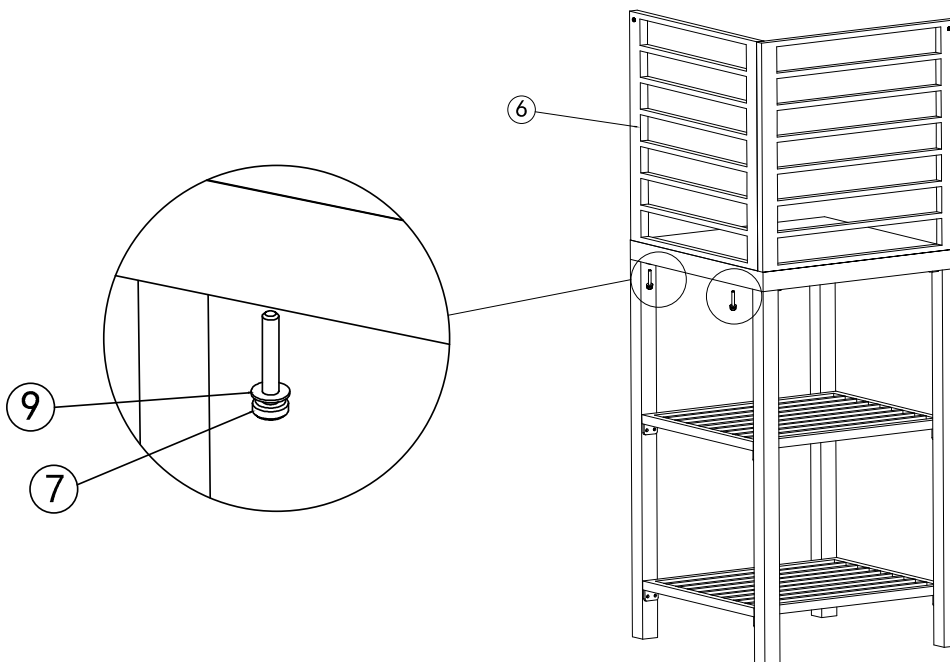

Step 6

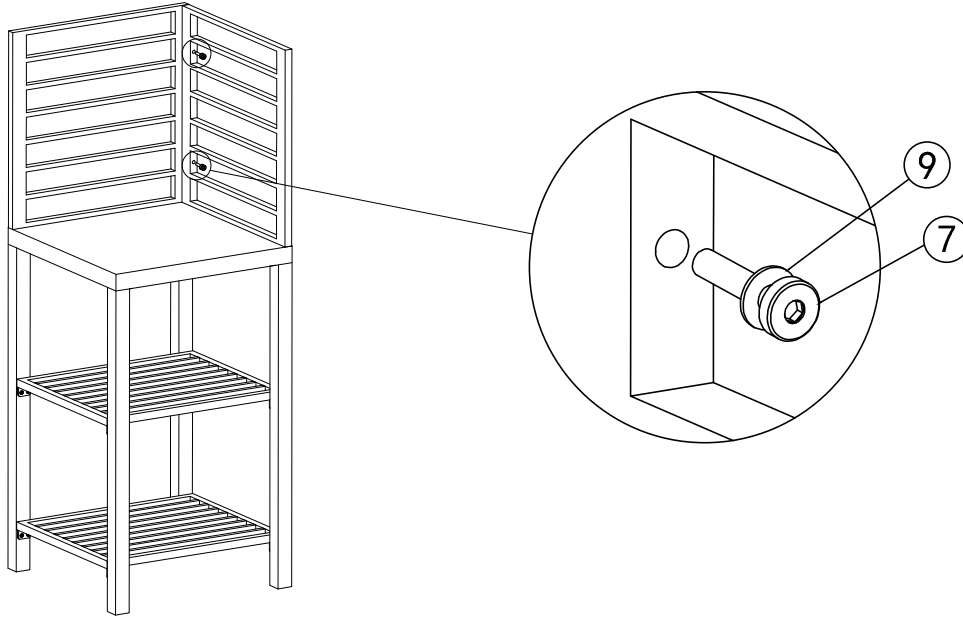
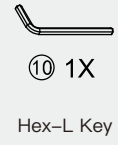
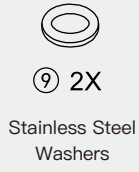
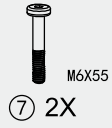

Step 7

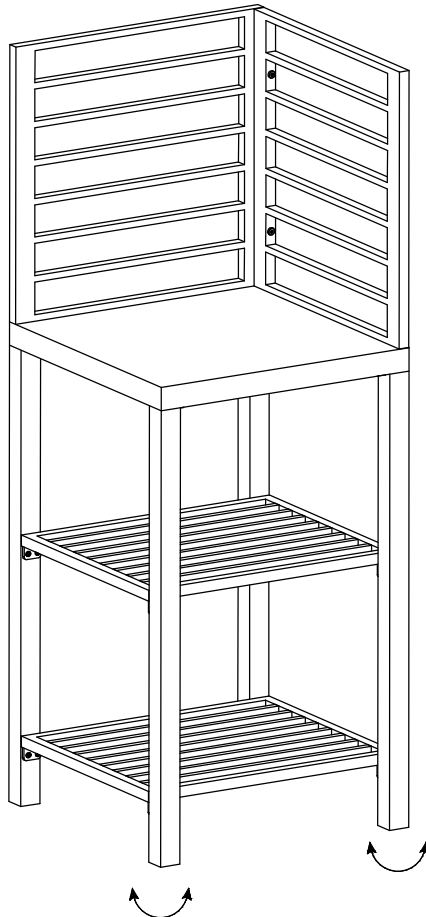

about the outdoor kitchen series

We created the Outdoor Kitchen line because we want everyone to enjoy the outdoors! All outdoor kitchen lines are modular in design, fit together seamlessly and are made of sturdy, durable aluminum countertops for easy connection. Like all domi outdoor products, the Outdoor Kitchen series has stood the test of time and will become a product that consumers trust.



Missing part? Damaged? Contact us via email at service@domioutdoorliving.com

www.domioutdoorliving.com

Series products



⑪ 1X

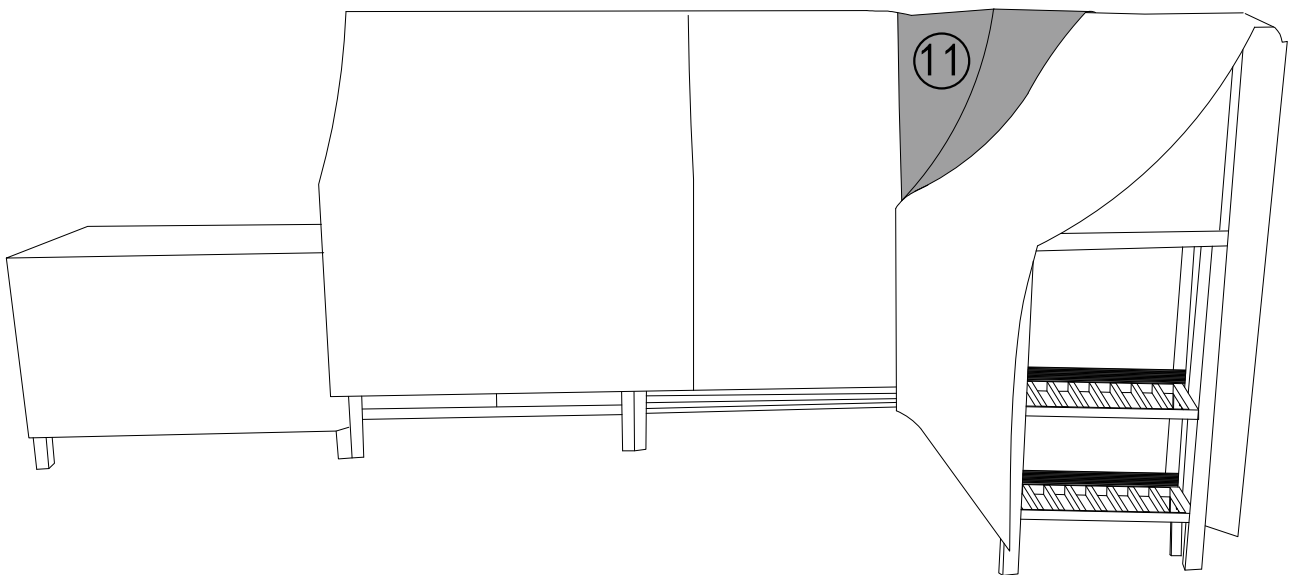
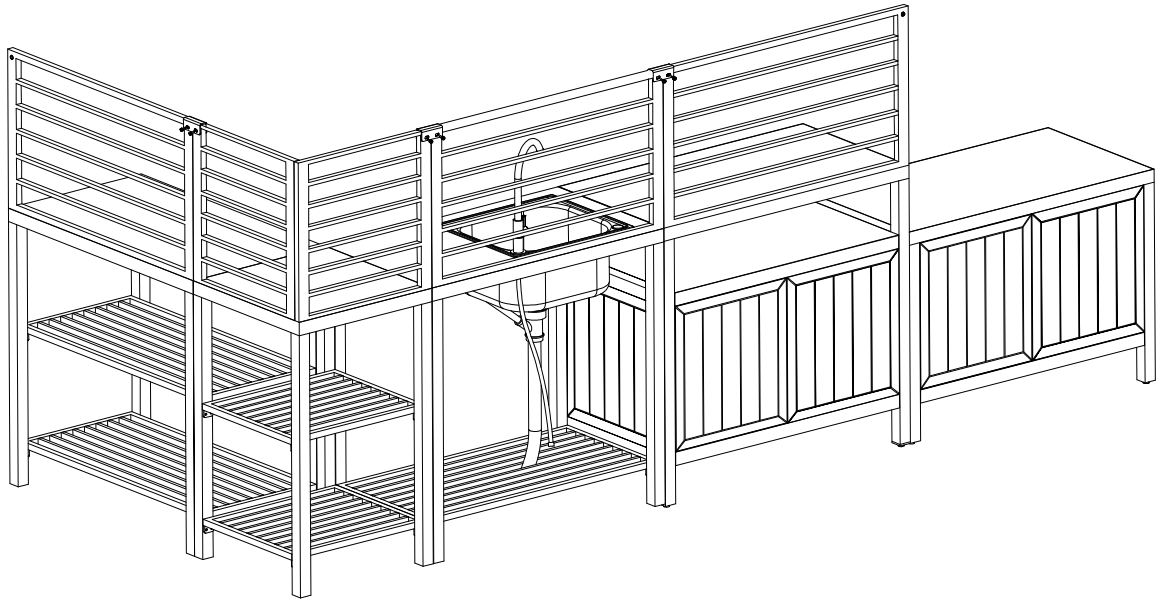

about the outdoor kitchen series

We created the Outdoor Kitchen line because we want everyone to enjoy the outdoors! All outdoor kitchen lines are modular in design, fit together seamlessly and are made of sturdy, durable aluminum countertops for easy connection. Like all domi outdoor products, the Outdoor Kitchen series has stood the test of time and will become a product that consumers trust.



Missing part? Damaged? Contact us via email at service@domioutdoorliving.com

www.domioutdoorliving.com
