

PAL - 1202

INSTRUCTIONM ANUAL

Hello! Please read these important attentions...

Please put a thick carpet on the ground to protect the furniture finish and corners. During the installation process, **DON'T** fasten screws tight 100% at a time.

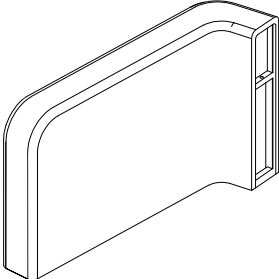
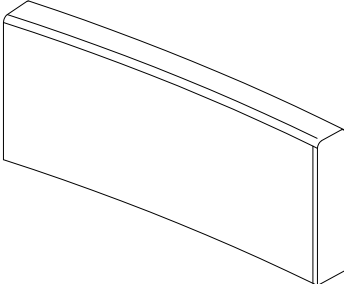
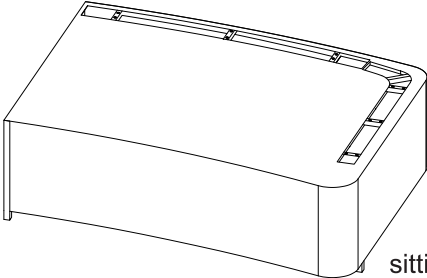
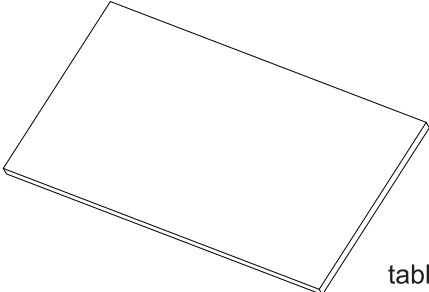

Assembly Instructions

NUMBER	COMPONENT	QUANTITY
A	 <p>handrail assembly</p>	2PCS
B	 <p>title cluster</p>	2PCS
C	 <p>sitting cluster</p>	2PCS
D	 <p>table top</p>	1PCS

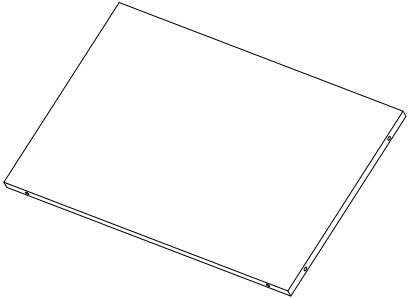
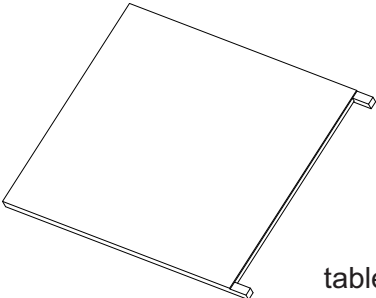
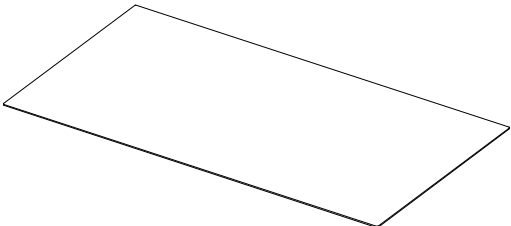
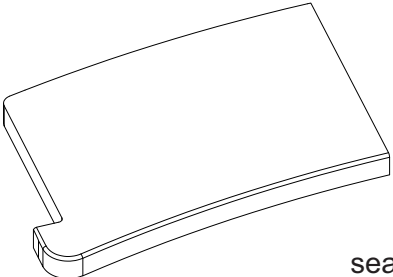
Assembly Instructions

NUMBER	COMPONENT	QUANTITY
E	 <p>side table</p>	2PCS
F	 <p>table's front</p>	2PCS
G	 <p>Glass surface</p>	1PCS
O	 <p>seat cushion</p>	2PCS

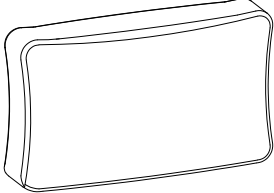
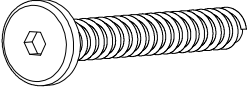
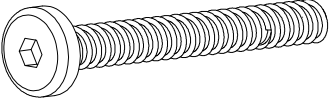
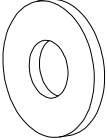
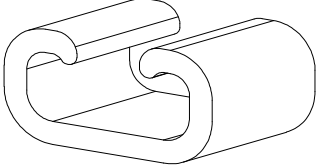
Assembly Instructions

NUMBER	COMPONENT	QUANTITY
M	 <p>backrest cushion</p>	3PCS
H	 <p>bolt M6x35mm</p>	12PCS
I	 <p>bolt M6x40mm</p>	24PCS
J	 <p>M6 shim</p>	36PCS
K	 <p>clamp</p>	6PCS
N	 <p>hexagon lock</p>	2PCS

Assembly Instructions

①

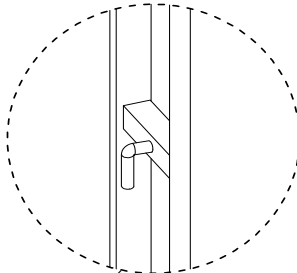
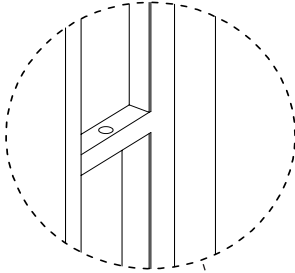
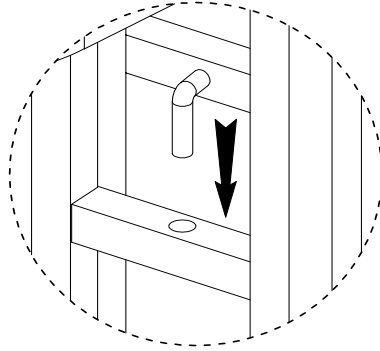

A

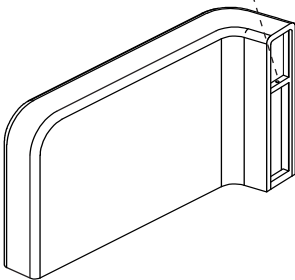

B

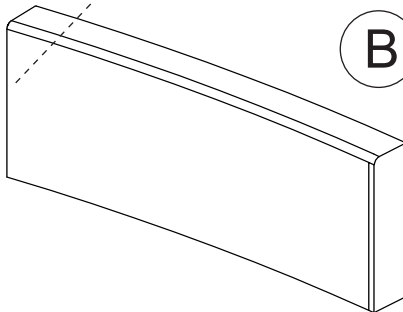

Attach the side hook of the backrest assembly (B) to the armrest assembly (A)

Assembly Instructions

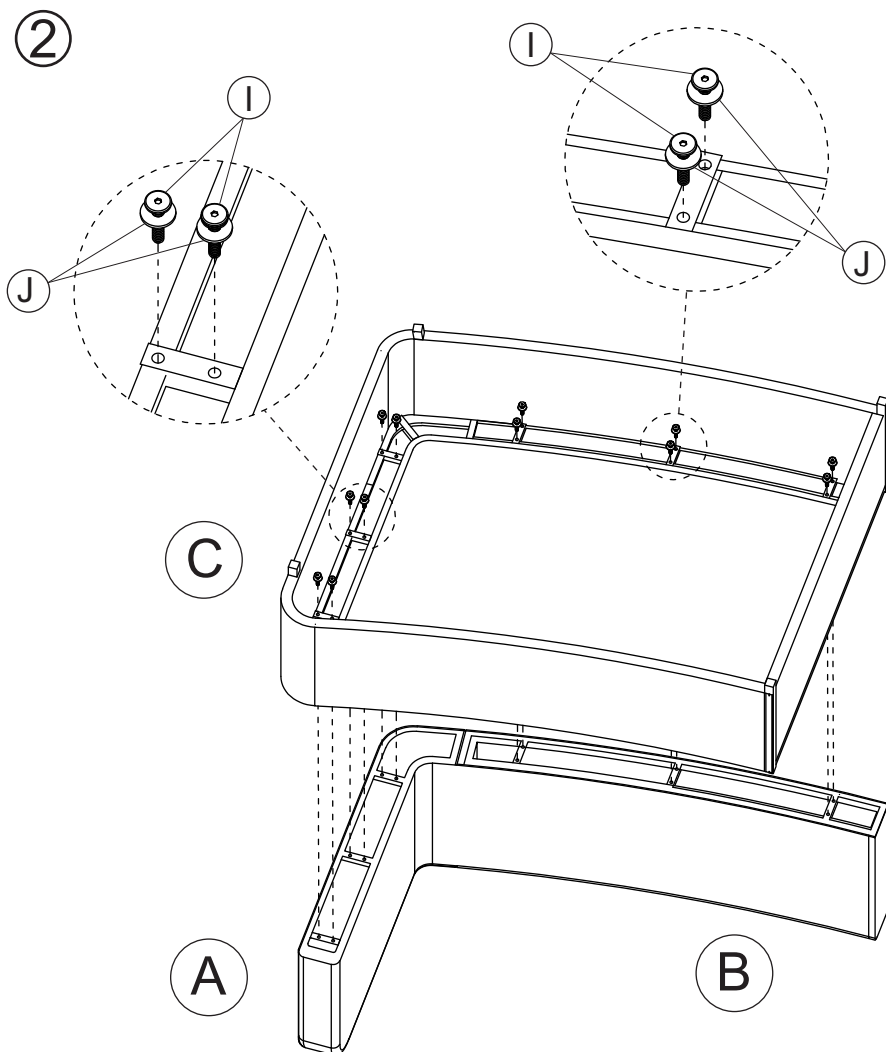

Uses hexagon lock (N), M6x40 screw (I) and shim (J) to connect sitting cluster (C) enter title cluster (B) and handrail assembly (A)
The best operation process needs to be done by 2 people

Assembly Instructions

③

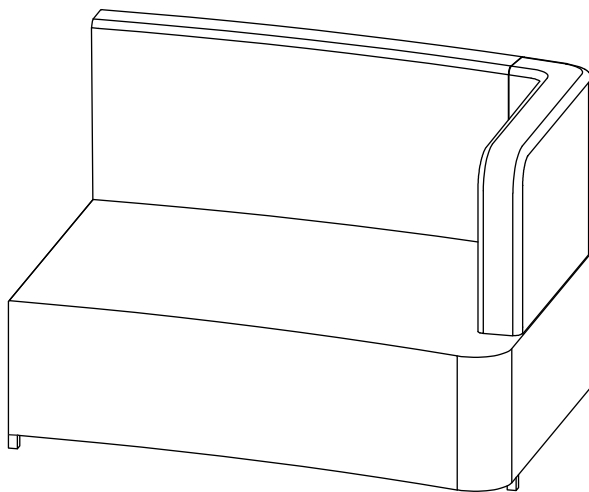
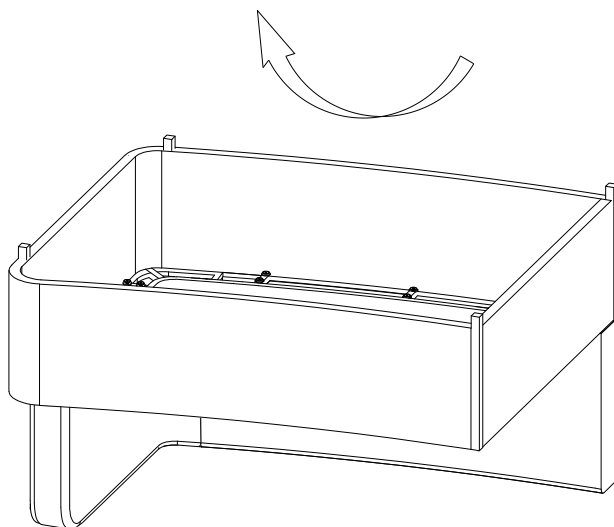

After tightening the screw, turn it over and you will have the left side of the daybed.

The right tape is assembled similarly to the left tape.

Assembly Instructions

4

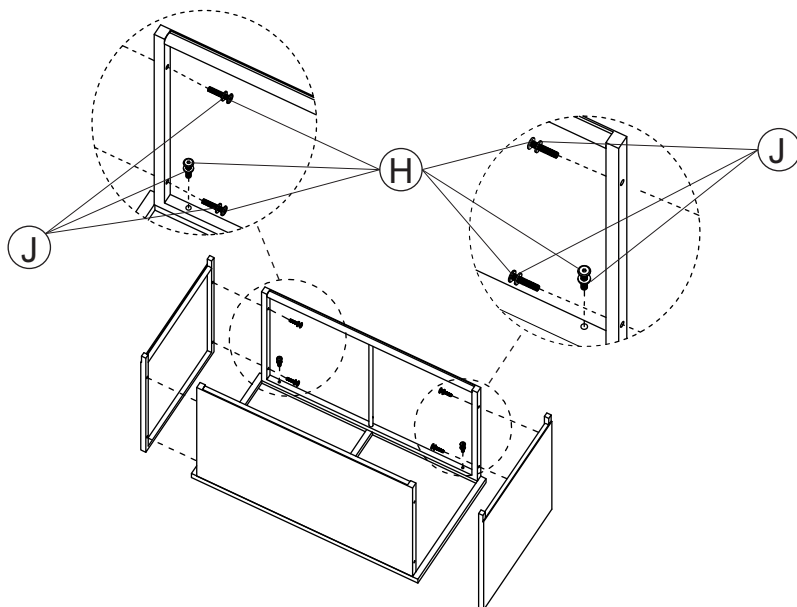
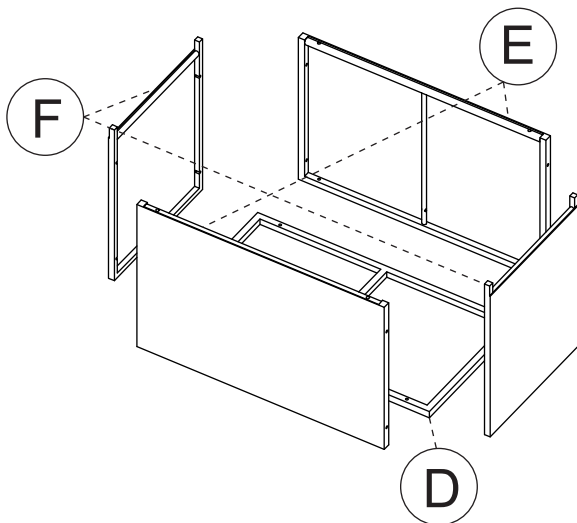

Uses hexagon lock (N), M6x35 screw (H) and shim (J) to connect table top (D), side table (E), before the table (F).

The best operation process needs to be done by 2 people

Assembly Instructions

5

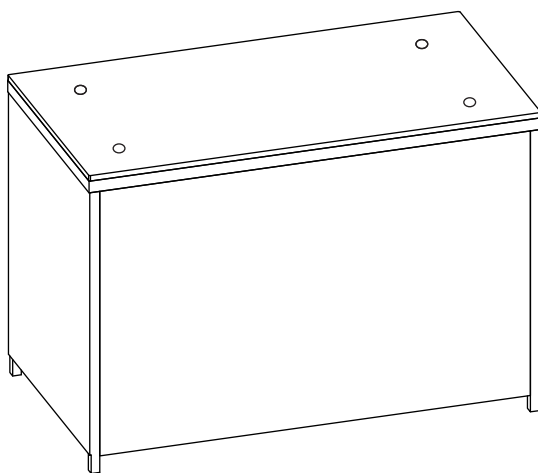
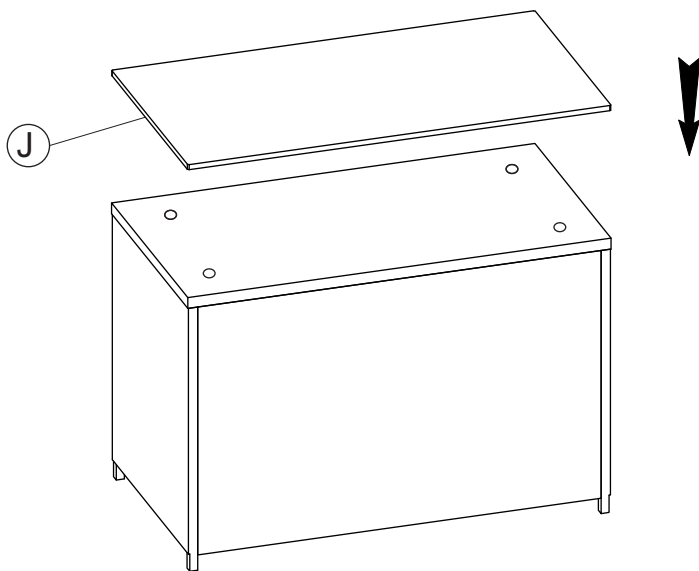

Place the glass on the table

Assembly Instructions

⑥

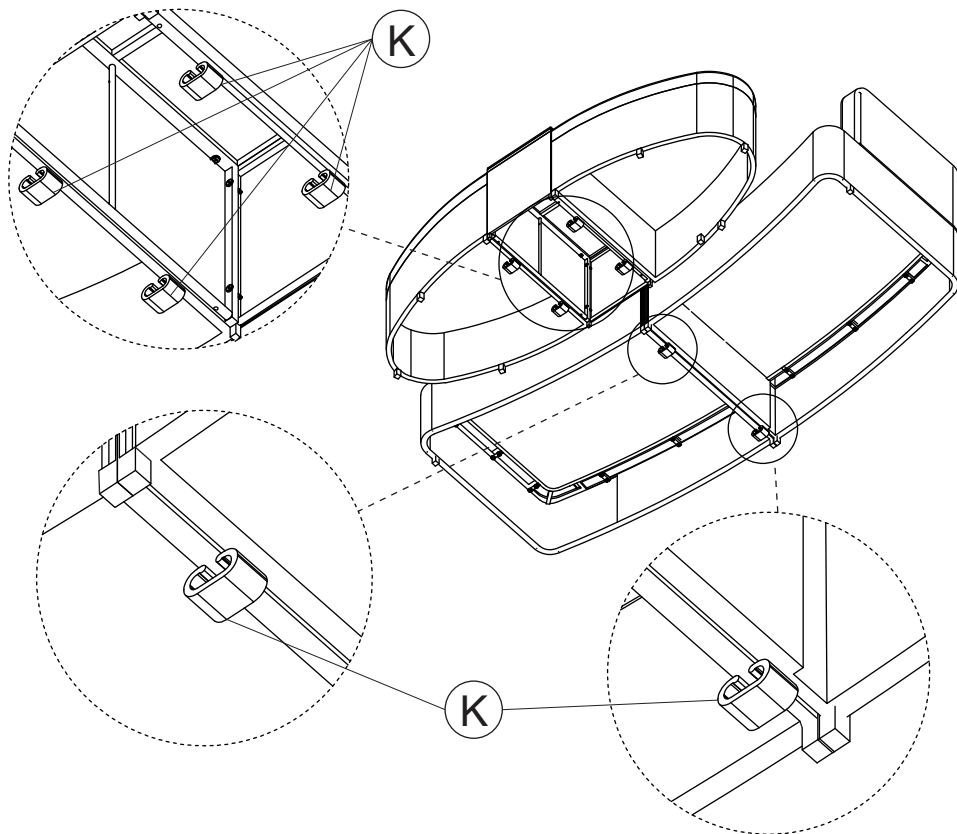

Use the clamp (K) to secure the Right daybed and Left daybed in case you want them not to separate.

Use the clamp (K) to secure the table and stool in place if you don't want them to separate.

Assembly Instructions

7

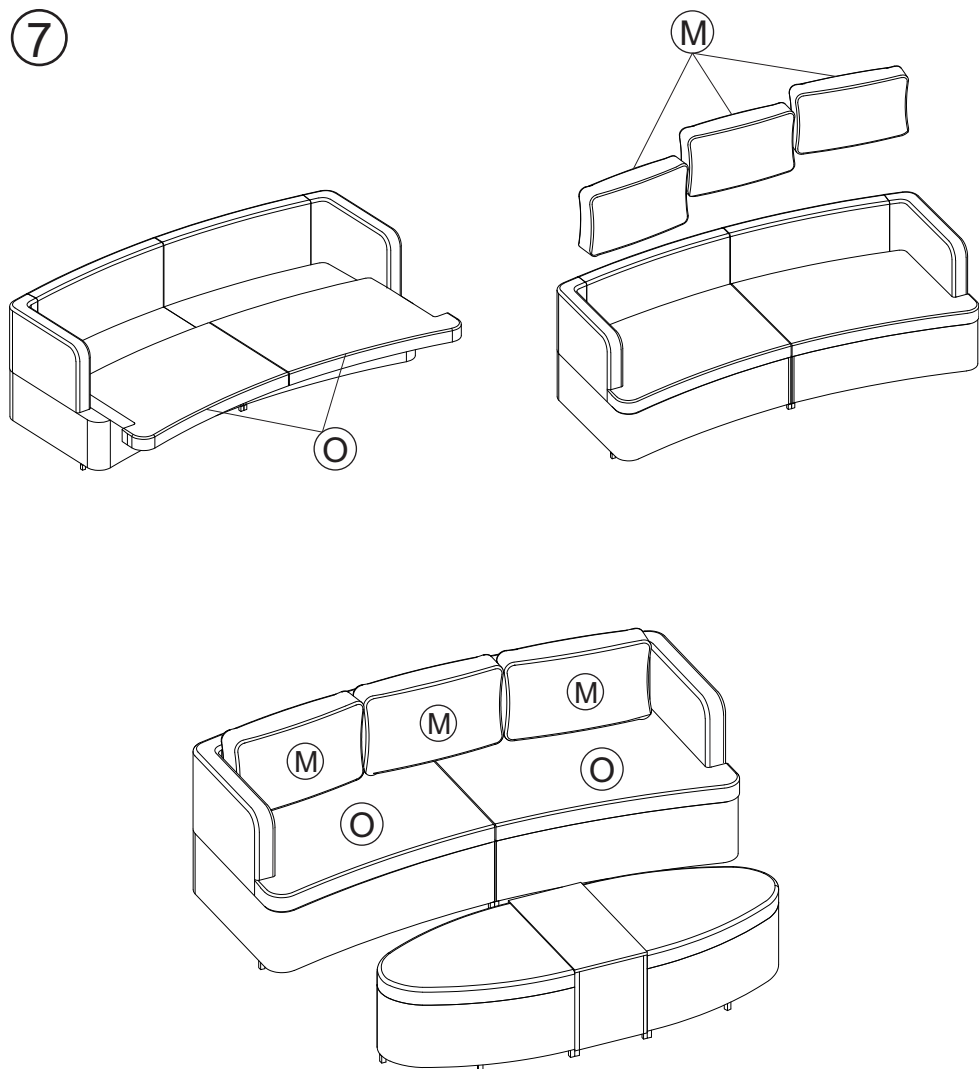

Put seat cushion (O) and backrest cushions (M) on the daybed then the assembly is done.



FORM FOR REPLACING MISSING OR DAMAGED PIECES.

Please email to : customerservice@directwicker.com

Model # of product : _____
Ordered by: _____
Ordered No: _____
Delivery date: _____

Were the boxes good when delivery to you Yes / No
Upon receiving the product, were all the parts intact Yes / No

Name : _____
Address : _____

Tel: _____

If you find the product damaged after assembly, please provide photos of entire furniture set and all damaged areas

Part#	Qty	Description	Missing/Damaged
			M / D
			M / D
			M / D
			M / D

If you do not receive a notification of the replacement parts within 1 week, please email us at customerservice@directwicker.com.



Customer Instruction Card

To our most beloved and valued customer:

Thank you for your order, and we appreciate your trust and support.

If you need any assistance or have any questions about your order, please reach our customer service team with your order number at:

Direct Wicker Corp Tel:(813)-304-1389

ET: 9 AM - 5 PM, Monday- Friday

If you would like to know more about Direct Wicker or need to forward documents, you can also reach us at: **customerservice@directwicker.com**

Our team will always be here to help.

Common Questions:

1. Normally the cushion is placed within the ottoman/ chair, please turn it upside down, you may find the cushion.
2. Please do not fully tighten the screws before all parts were assembled successfully, in case the products can not be lined up in position.
3. Furniture sets are mostly delivered in multiple cartons. If the numbers of boxes you received are not correct/missing. Please contact us via phone or email with your order number.
4. Our cushions are considered as shower proof, and we recommend that when the furniture set is not in use , cover it with a furniture cover or store it in dry place.
5. Always be careful when cleaning or handling glass (Always wear gloves and read the instructions of any household cleaner.) We do not advise placing hot objects such as tea or coffee pots directly onto the surface of the glass, always use coasters.
6. If you would like to return the order, be sure to also return any accessories and packing slips that came with your original package.
7. For all your accessory needs, please visit our brand's official website: **directwicker.com**.
8. To preserve the longevity and beauty of your glass-topped wicker table, we recommend placing it in a shaded area away from direct sunlight. Additionally, please use a rain cover to protect it when not in use.

Thank you for your understanding and cooperation, we wish you a fantastic shopping experience with us, and we are looking forward to serving you again!

Direct Wicker Team

A stylized illustration of a hand holding a bouquet of flowers. The bouquet consists of several stems with small, round flowers in shades of pink and light blue. The hand is shown from the side, holding the stems.

Your Home Our Passion



For more information, please visit our website:

www.directwicker.com