

NOTICE

- * Please make sure that you have all parts indicated and they are in good condition before you begin assembly of this item. Refer to part list and hardware list below for guidance.
- * This item should be assembled on a soft surface to prevent scratching the finish during assembly.
- * This item may require periodic tightening.
- * If you are having difficulty, our friendly Customer Care team is always here to help.





PREPARATION

- * Before beginning assembly of product, make sure all parts are present. Compare parts with part contents list and hardware contents list.
- * If any part is missing or damaged, do not attempt to assemble the product.
- * Estimated Assembly Time: 10 minutes
- * Tools Required for Assembly (included): Allen Key

CARE AND MAINTENANCE

- * Wipe up spills immediately and avoid common hazards such as hot dishes, harsh solvents and abrasives.
- * Cleaning should be done with a soft lint free cotton cloth dampened with water or furniture polish.
- * On highly used surfaces we recommend applying a quality paste wax which should be used on a regular basis to provide additional protection from scratches and spills. How often you apply the wax depends on how much wear the furniture receives.

Part List and Hardware List

PIECE	DESCRIPTION	PICTURE	QUANTITY	CARTON CALL
A	Top		1X	1 of 2
B	Legs		2X	2 of 2
HW1	Allen Bolt (8x1.25x30mm)		6X	2 of 2
HW2	Metal Washer (8x20mm)		6X	2 of 2
HW3	Allen Key (5mm)		1X	2 of 2

Product Dimension: 51 X 28 X 16 INCH

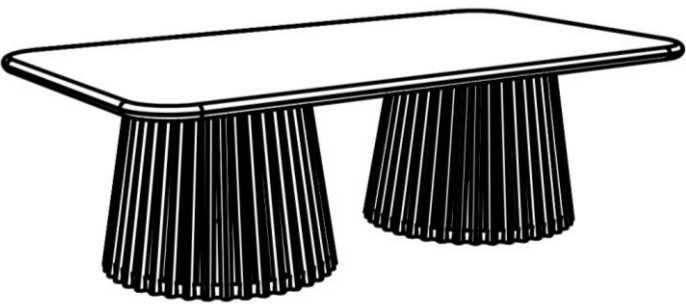

Weight Capacity: 200 LBS
Warning: Do not stand on table
Warning: Do not over torque bolts

PREPARATION

- * Before beginning assembly of product, make sure all parts are present. Compare parts with part contents list and hardware contents list.
- * If any part is missing or damaged, do not attempt to assemble the product.
- * Estimated Assembly Time: 10 minutes
- * Tools Required for Assembly (included): Allen Key
- * If you are having difficulty, our friendly Customer Care team is always here to help.

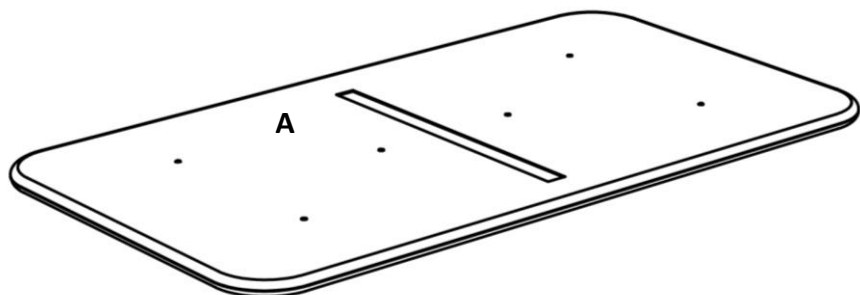

STEP1: LAY THE TABLE TOP (A) UPSIDE DOWN ON A SOFT, CLEAN SURFACE.

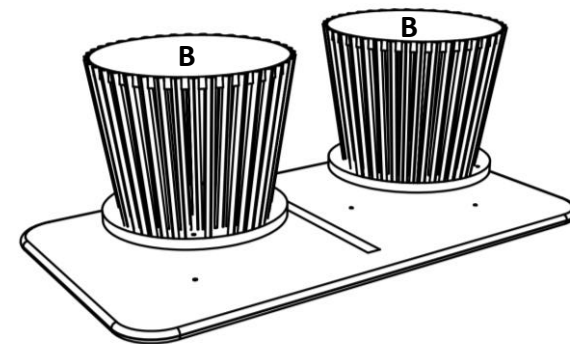

STEP2: ALIGN THE SCREW HOLES ON THE LEGS (B) TO THE SCREW HOLES ON THE TABLE TOP (A).

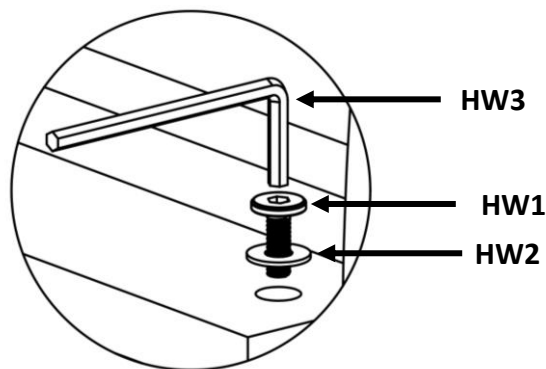

STEP3: USE THE ALLEN KEY (HW3) TO SCREW THE ALLEN BOLTS (HW1) THROUGH THE METAL WASHERS (HW2) AND ATTACH THE LEGS TO THE TABLE TOP. REPEAT FOR ALL THE LEGS.

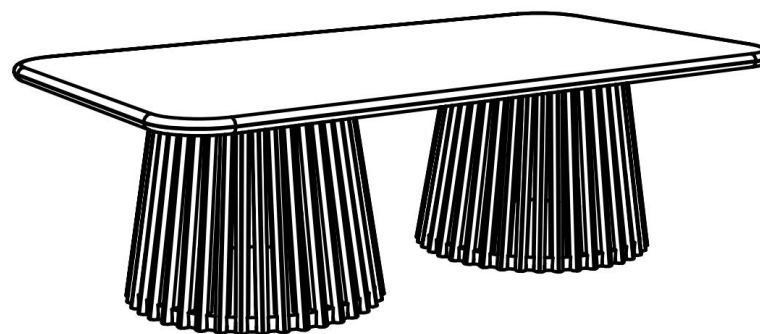

STEP4: TURN THE COFFEE TABLE UPRIGHT. YOUR COFFEE TABLE IS NOW READY TO USE.