

ASSEMBLY INSTRUCTION

MODEL : 37600 - TWIN & FULL BUNK BED (990/1400 X 1905)MM

Page 1

ACME FURNITURE

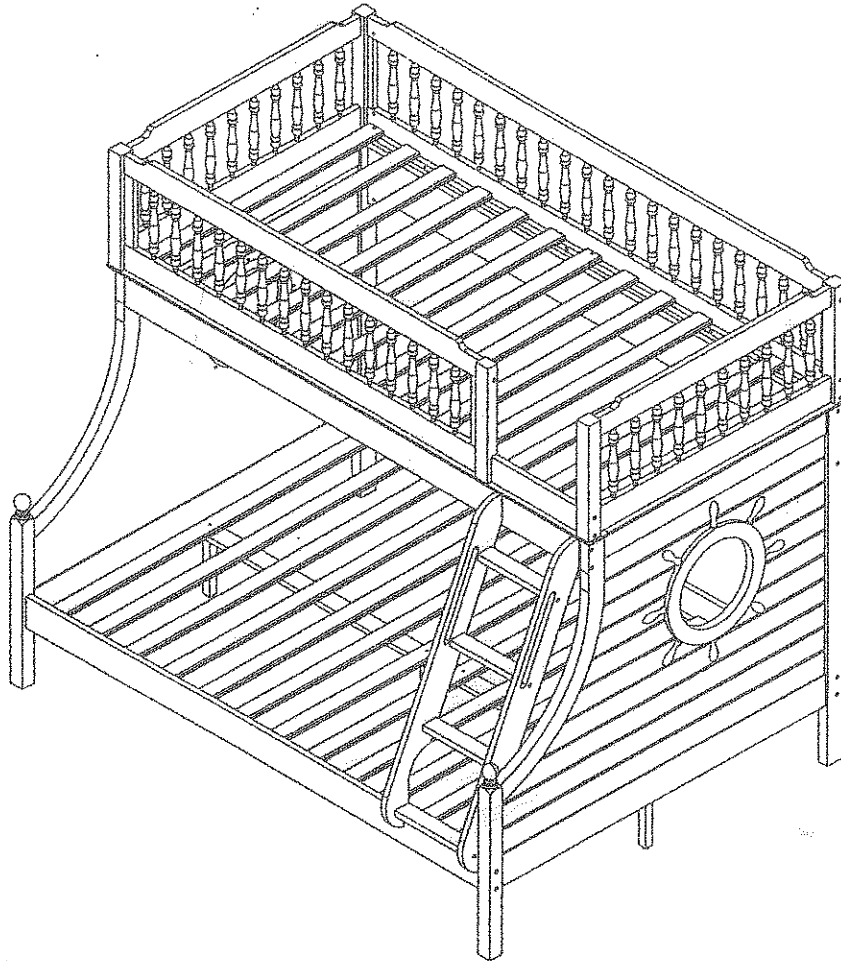







**READ THESE INSTRUCTIONS CAREFULLY
BEFORE ATTEMPTING TO ASSEMBLE THIS BED.**

SAFETY WARNINGS AND GENERAL NOTES:

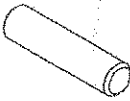
- Follow the information on the warnings appearing on the upper bunk bed end structure and on the carton. Do not remove the warning label from the bed.
- Always use the recommended size mattress or mattress support, or both, to help prevent the likelihood of entrapment or falls. (See Page 11)
- The top surface of the mattress must be at least 5" below the upper edge of the guardrails. (See Page 11)
- Do not allow children under 6 years of age to use the upper bunk.
- Periodically check and ensure the guardrail, ladder and other components are in their proper position, free from damage, and all connectors are tight.
- Prohibit horseplay on or under the bed. Always prohibit jumping on the bed.
- Prohibit more than one person on upper bunk.
- Always use the ladder for entering and leaving the upper bunk.
- Do not use substitute parts. Contact the manufacturer or dealer for replacement parts.
- Use of a night-light may provide added safety precaution for a child using the upper bunk.
- Always use guardrails on both long sides of the upper bunk.
- If the bunk bed will be placed next to a wall, the guardrail that runs the full length of the bed should be placed against the wall to prevent entrapment between the bed and the wall.
- The use of water or sleep flotation mattresses is prohibited.
- Keep these instructions for future reference.
- We recommend assembling your bunk bed on the shipping carton to protect your floor or carpet. Be certain all staples are out of the box before beginning assembly on the shipping carton.

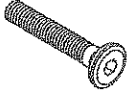
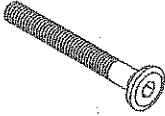
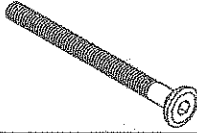
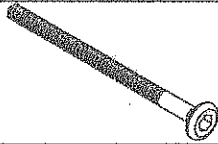
STRANGULATION HAZARD - Never attach or hang items to any part of the bunk bed that are not designed for use with the bed; for example, but not limited to, hooks, belts, and jump ropes.

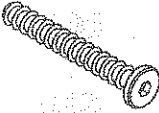
HARDWARE LIST :

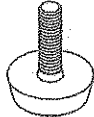
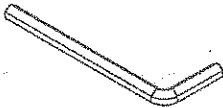
ITEM	QTY	DESCRIPTION
A	30	 WOOD DOWEL (M10 X 35MM)
B	8	 PLASTIC DOWEL (M8 X 30MM)
C	10	 JCBC BOLT (M6 X 35MM)
D	10	 JCBC BOLT (M6 X 50MM)
E	15	 JCBC BOLT (M6 X 70MM)
F	16	 JCBC BOLT (M6 X 80MM)
G	38	 JRN NUT (M6 X 13MM)
H	8	 JCBC W SCREW (M7 X 50MM)
I	12	 CSK C/B SCREW (M4 X 32MM)
J	3	 BASE GLIDER
K	1	 ALLEN KEY (M4 X 60MM)

- The assembly will require at least two people to complete.
- Make sure all the fasteners are tight.
- Due to the size of this bed, it must be assembled within the space it will occupy.
- Above all, take your time and read the instruction carefully.

TOOLS REQUIRED :
Crosshead Screwdriver

PARTS LIST :

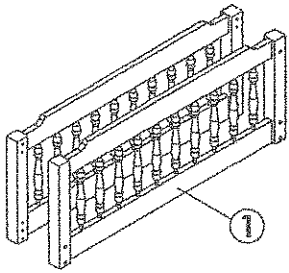

TOP HEADBOARD
(2 PCS / SET)
CARTON 1 OF 4

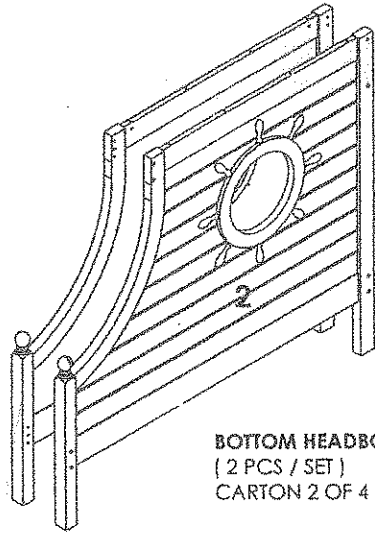

BOTTOM HEADBOARD
(2 PCS / SET)
CARTON 2 OF 4

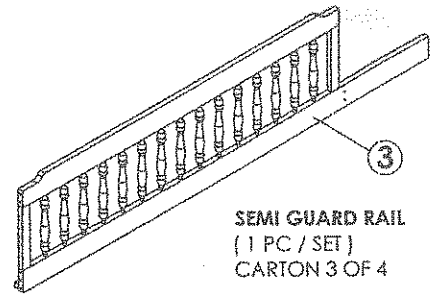

SEMI GUARD RAIL
(1 PC / SET)
CARTON 3 OF 4

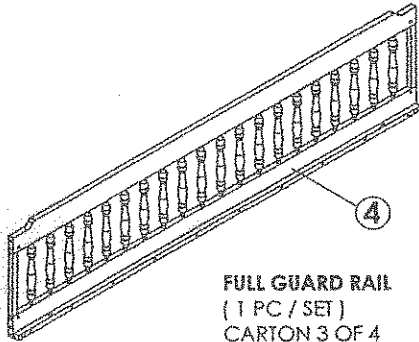

FULL GUARD RAIL
(1 PC / SET)
CARTON 3 OF 4



SEMI GUARD RAIL SUPPORT
(1 PC / SET)
CARTON 3 OF 4

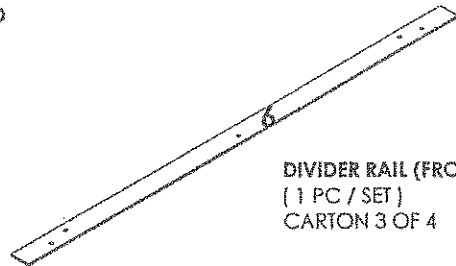

DIVIDER RAIL (FRONT)
(1 PC / SET)
CARTON 3 OF 4

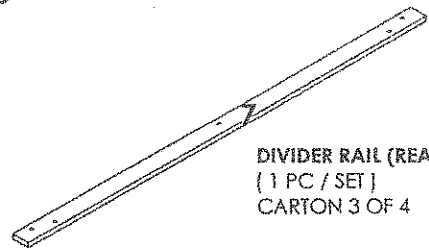

DIVIDER RAIL (REAR)
(1 PC / SET)
CARTON 3 OF 4

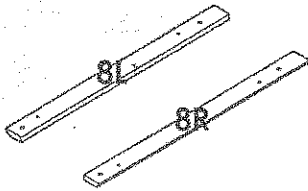

DIVIDER RAIL (SIDE)
(2 PCS / SET)
CARTON 3 OF 4

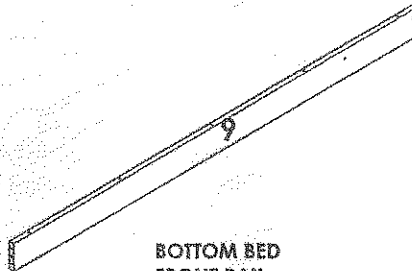

BOTTOM BED FRONT RAIL
(1 PC / SET)
CARTON 3 OF 4

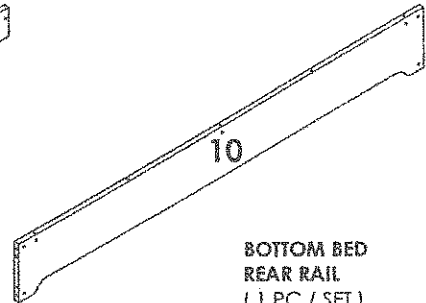

BOTTOM BED REAR RAIL
(1 PC / SET)
CARTON 3 OF 4

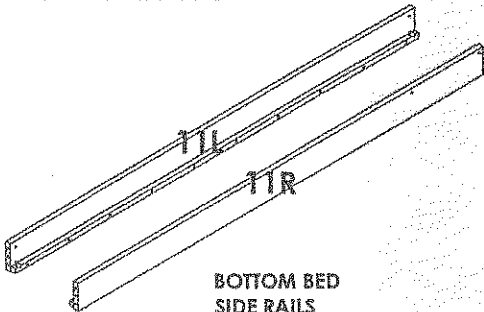

BOTTOM BED SIDE RAILS
(2 PCS / SET)
CARTON 3 OF 4

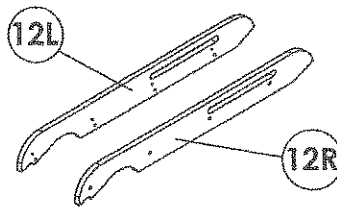

LADDER SIDES
(2 PCS / SET)
CARTON 3 OF 4

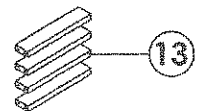

LADDER SLATS
(4 PCS / SET)
CARTON 3 OF 4

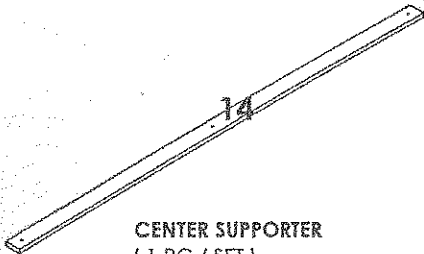

CENTER SUPPORTER
(1 PC / SET)
CARTON 3 OF 4



SUPPORTER LEGS
(3 PCS / SET)
CARTON 3 OF 4

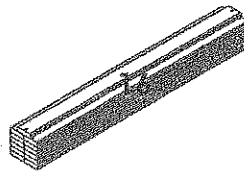

WOODEN SLATS (TOP)
(13 PCS / SET)
CARTON 1 OF 4

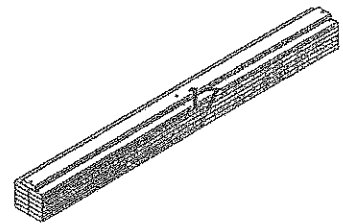

WOODEN SLATS (BOTTOM)
(13 PCS / SET)
CARTON 4 OF 4

STEP 1

1. Insert the Wood Dowels (A) into $\varnothing 10\text{MM}$ holes on Full Guard Rail, Semi Guard Rail, Bottom Bed Front Rail, Bottom Bed Rear Rail, Bottom Bed Side Rails & Ladder Slats by using a Rubber Hammer as shown in Figure 1.

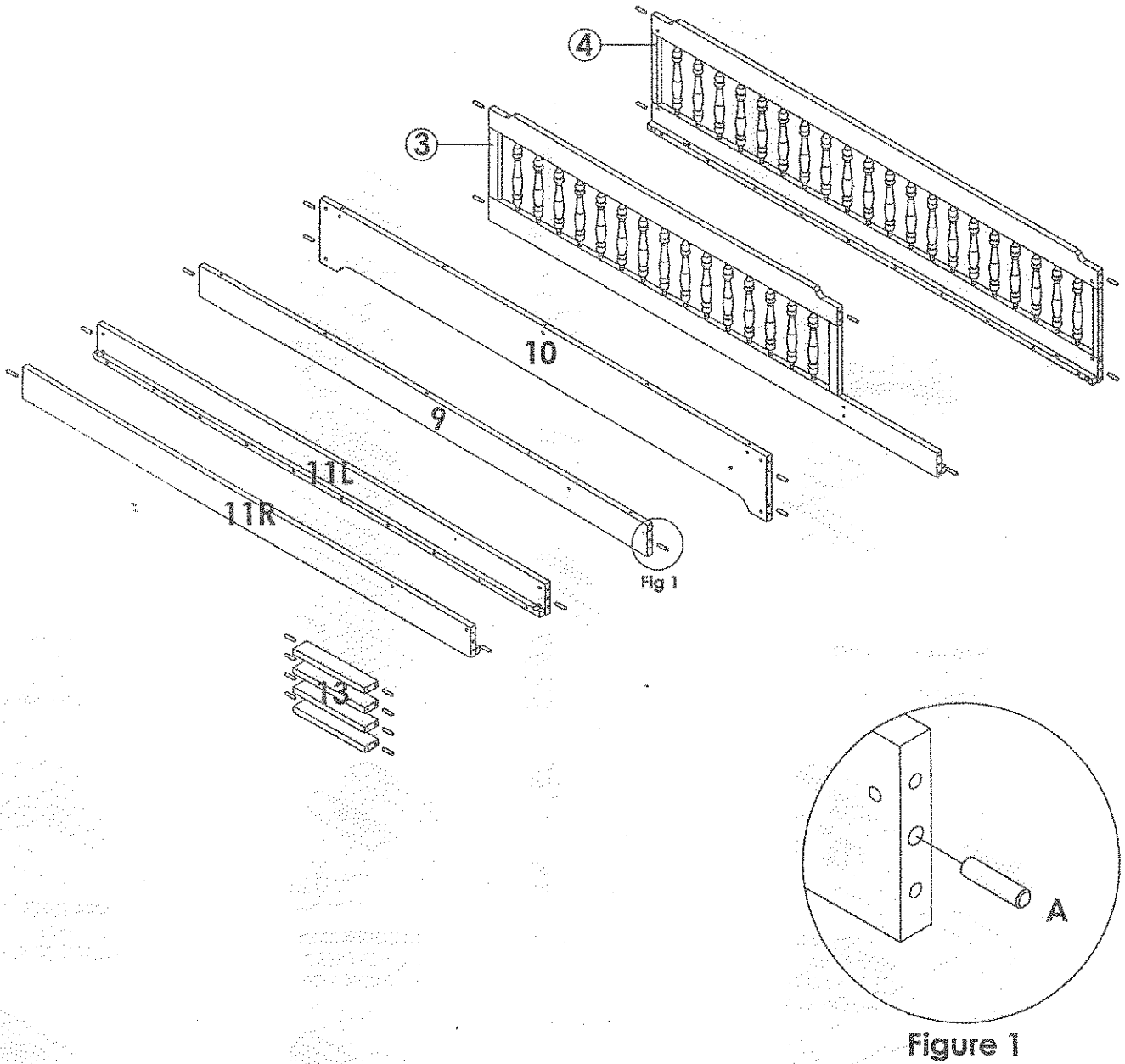

HARDWARE USED IN THIS STEP

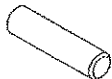
A	26		WOOD DOWEL (M10 X 35MM)
---	----	---	----------------------------

STEP 2

1. Insert JRN Nuts (G) into the holes on Bottom Bed Side Rails, Front Rail and Rear Rail as shown in Figure 2.
 2. Attach front Bottom Bed Side Rail to Bottom Headboards by using JCBC Bolts (F), tighten it up by using an Allen Key (K) as shown in Figure 3.
 3. Attach rear Bottom Bed Side Rail, Bottom Bed Front & Rear Rail to Bottom Headboards by using JCBC Bolts (E), tighten it up by using an Allen Key (K) as shown in Figure 4.
- * The Bottom Side Rail with 2 EXTRA HOLES on surface needs to be attached on Bottom Headboard side with curve edge.

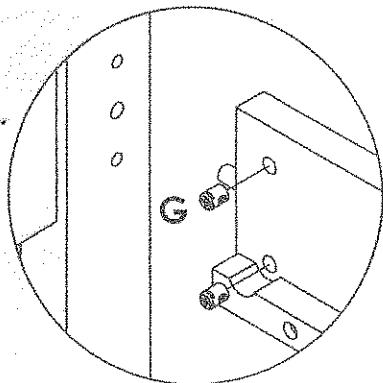
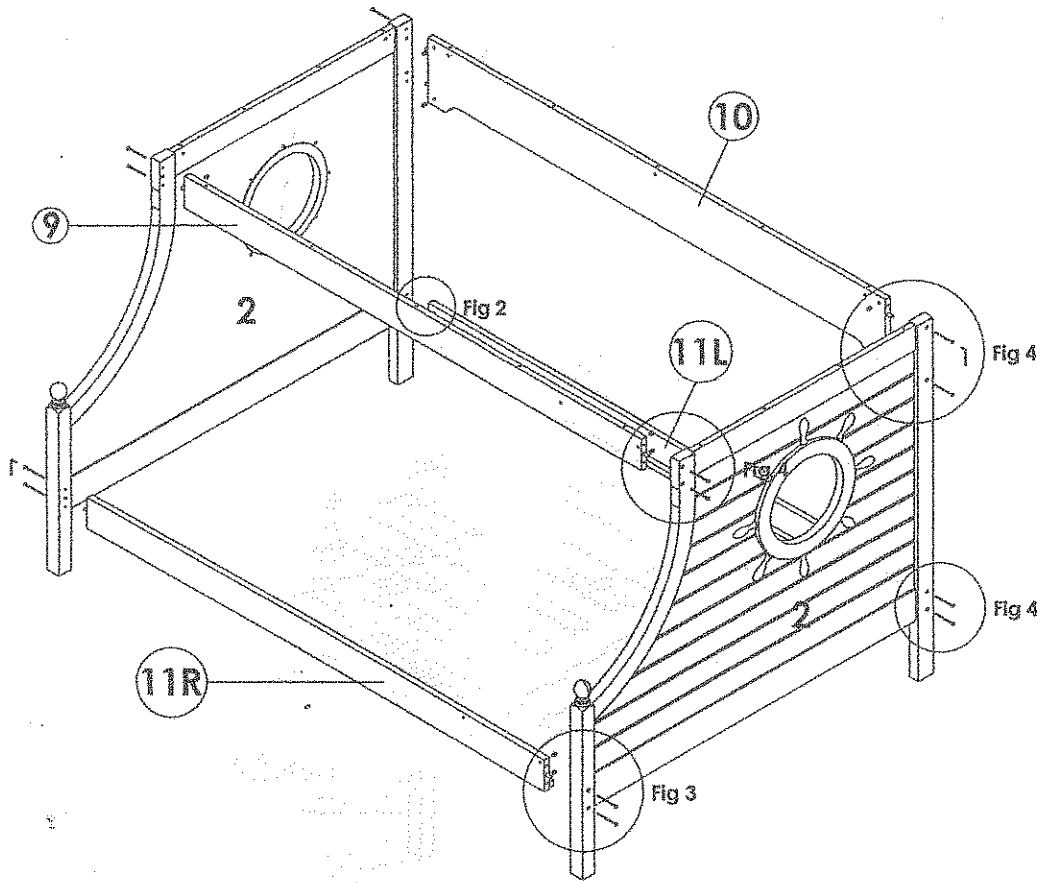

Figure 2

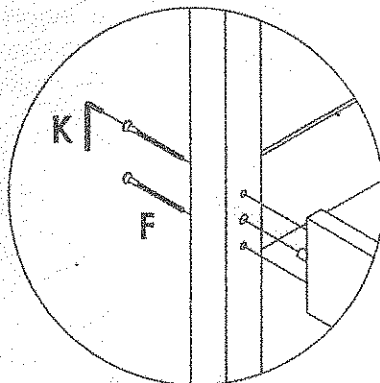

Figure 3

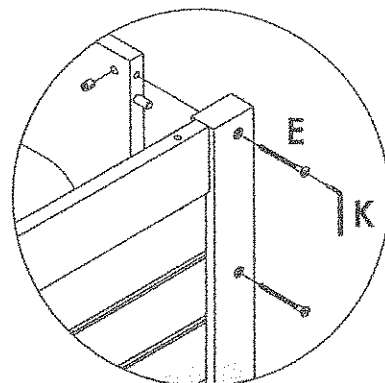

Figure 4

HARDWARE USED IN THIS STEP

E	12		JCBC BOLT (M6 X 70MM)
F	4		JCBC BOLT (M6 X 80MM)
G	16		JRN NUT (M6 X 13MM)
K	1		ALLEN KEY (M4 X 60MM)

STEP 3

1. Screw **Base Glider (J)** under **Supporter Legs** as shown on **Figure 5**.
2. Lay **Center Supporter** onto **Supporter Legs** WITHOUT TIGHTENING IT UP. Position **Center Supporter** and **Supporter Legs** in the middle of **Bottom Bed**.
3. Secure **Bottom Wooden Slats** onto **Center Supporter** and **Supporter Legs** by using **JCBC Bolts (E)**, tighten it up by using an **Allen Key (K)** as shown in **Figure 6**.
4. Secure the **Bottom Wooden Slats** in place by treading **CSK C/B Screws (I)** through the predrilled holes on both ends of **Bottom Wooden Slats** as shown in **Figure 7**.

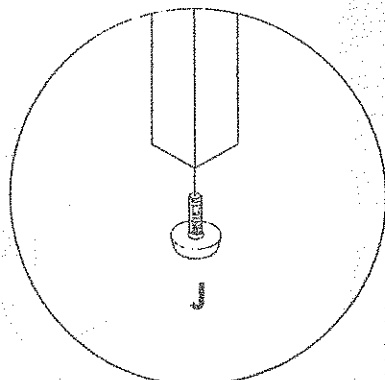
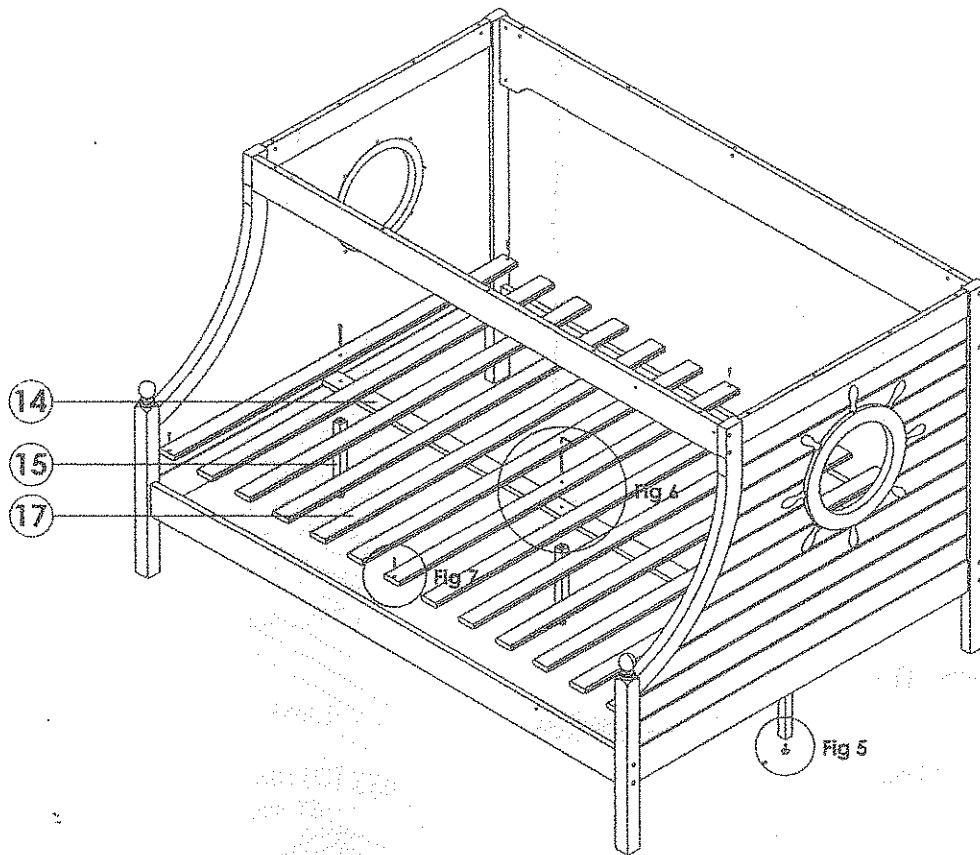

Figure 5

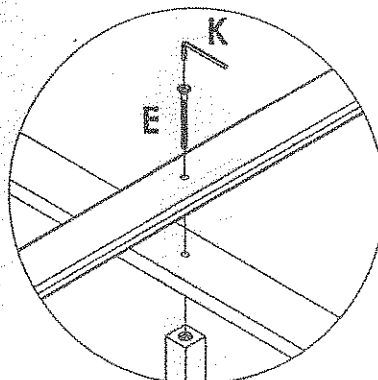

Figure 6

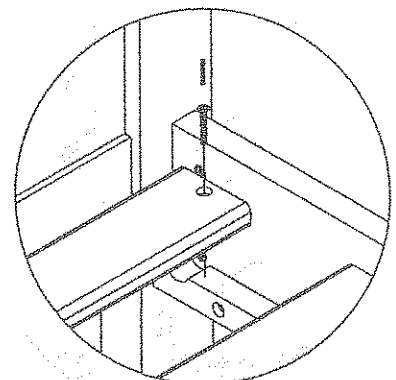

Figure 7

HARDWARE USED IN THIS STEP

E	3		JCBC BOLT (M6 X 70MM)
I	6		CSK C/B SCREW (M4 X 32MM)
J	3		BASE GLIDER
K	1		ALLEN KEY (M4 X 60MM)

STEP 4

1. Attach and secure **Divider Rails (Front, Rear & Side)** onto **Bottom Bed**. Insert the **Plastic Dowels (B)** into $\text{Ø}8\text{MM}$ holes by using a **Rubber Hammer** as shown in **Figure 8**.
2. Secure the **Dividers** in place by inserting **JRN Nut (G)** into holes on **Bottom Bed Front Rail**, **Bottom Bed Rear Rail** and **Bottom Headboards**, attach **JCBC Bolt (D)** and tighten it up by using an **Allen Key (K)** as shown in **Figure 9**.

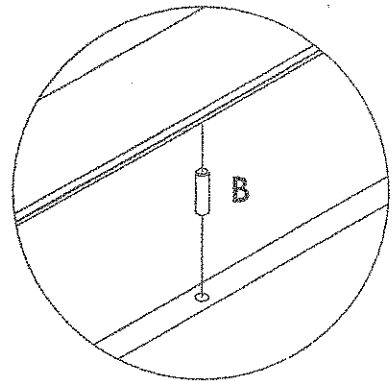
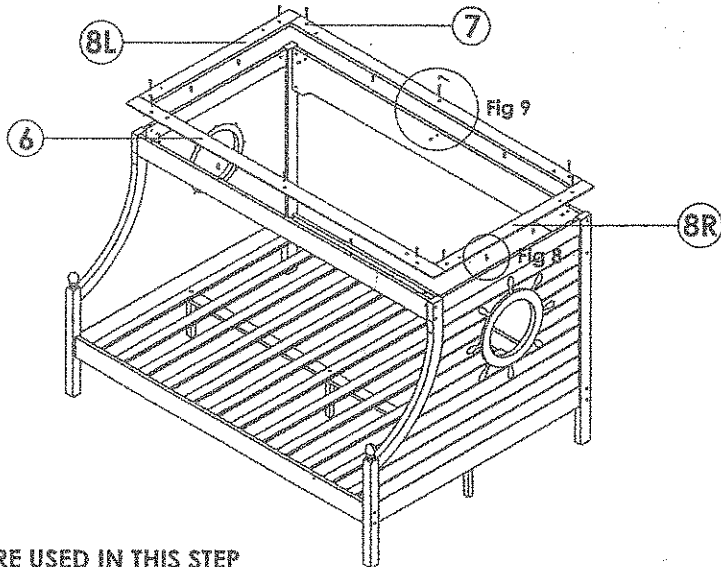

Figure 8

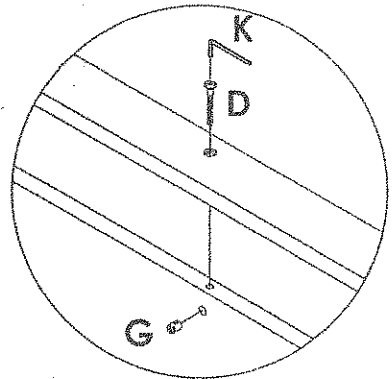

Figure 9

HARDWARE USED IN THIS STEP

B	8		PLASTIC DOWEL (M8 X 30MM)
D	10		JCBC BOLT (M6 X 50MM)
G	10		JRN NUT (M6 X 13MM)
K	1		ALLEN KEY (M4 X 60MM)

STEP 5

1. Insert **JRN Nut (G)** into the holes found on **Semi Guard Rail**, screw in **JCBC Bolt (F)** by using an **Allen Key (K)** as shown in **Figure 10**.
2. Secure **Semi Guard Rail Support** onto **Semi Guard Rail** by using **JCBC Bolts (C)**, tighten it up by using an **Allen Key (K)** as shown in **Figure 11**.

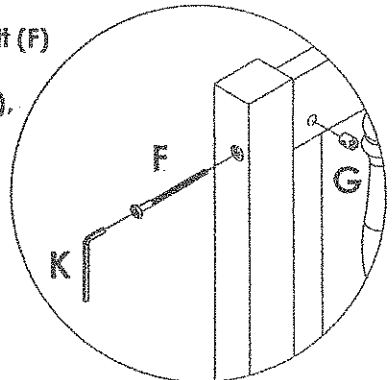
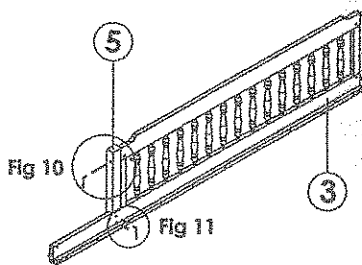

Figure 10

HARDWARE USED IN THIS STEP

C	2		JCBC BOLT (M6 X 35MM)
F	1		JCBC BOLT (M6 X 80MM)
G	1		JRN NUT (M6 X 13MM)
K	1		ALLEN KEY (M4 X 60MM)

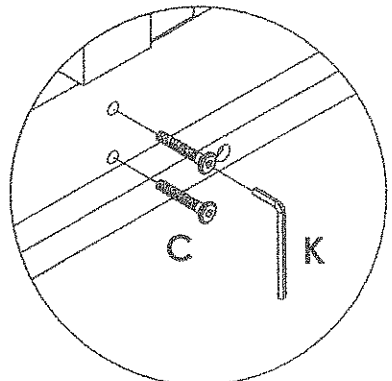

Figure 11

STEP 6

1. Insert JRN Nuts (G) into the holes found on each Guard Rails as shown in Figure 12.
2. Attach the Top Headboards to the both Guard Rails as shown by using JCBC Bolts (F) and tighten it up by using an Allen Key (K) as shown in Figure 13.

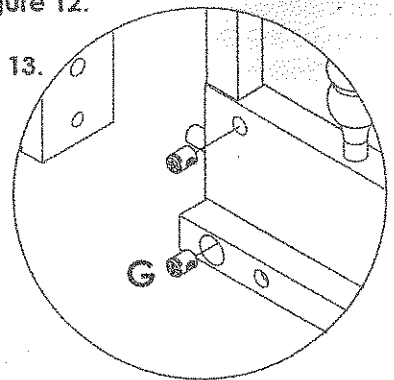
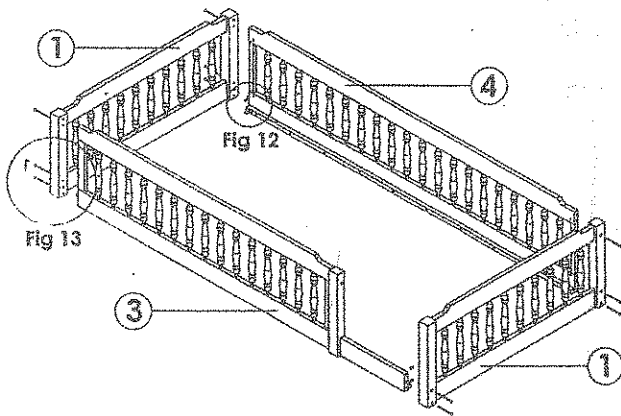

Figure 12

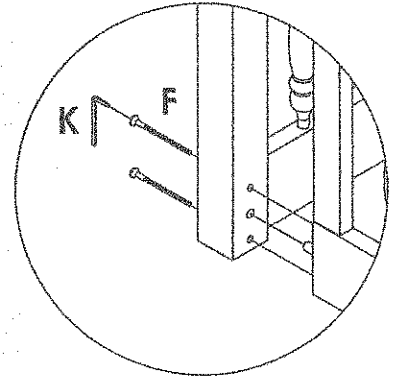

Figure 13

HARDWARE USED IN THIS STEP

F	11		JCBC BOLT (M6 X 80MM)
G	11		JRN NUT (M6 X 13MM)
K	1		ALLEN KEY (M4 X 60MM)

STEP 7

1. Connect Top Bed and Bottom Bed together by inserting Wood Dowels (A) into Ø10MM holes on Dividers as shown in Figure 14.
2. Secure it by screwing JCBC Bolts (C) through slat supporter's Ø8MM holes, tighten it up by using an Allen Key (K) as shown in Figure 15.

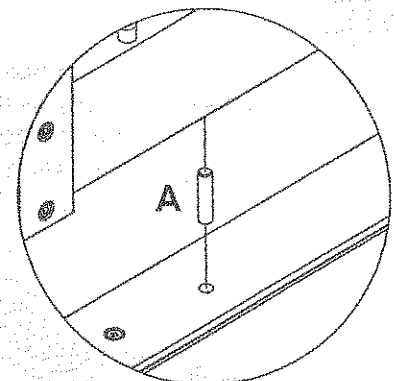
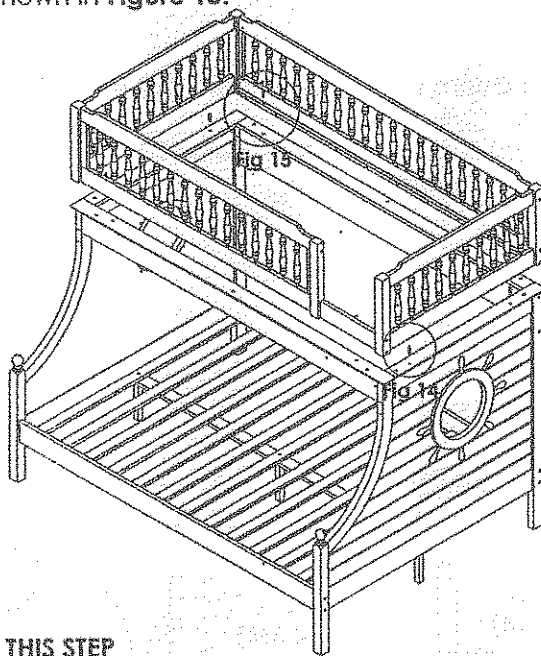

Figure 14

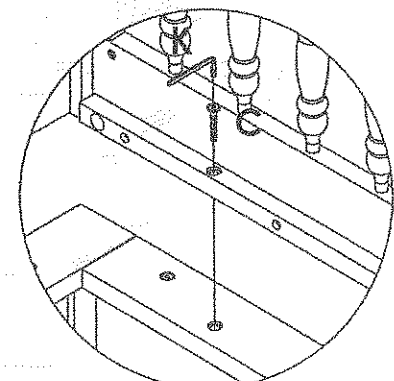

Figure 15

HARDWARE USED IN THIS STEP

A	4		WOOD DOWEL (M10 X 35MM)
C	4		JCBC BOLT (M6 X 35MM)
K	1		ALLEN KEY (M4 X 60MM)

STEP 8

1. Secure the **Top Wooden Slats** in place by treading **CSK C/B Screws (I)** through the predrilled holes on both ends of **Top Wooden Slats** as shown in **Figure 16**.

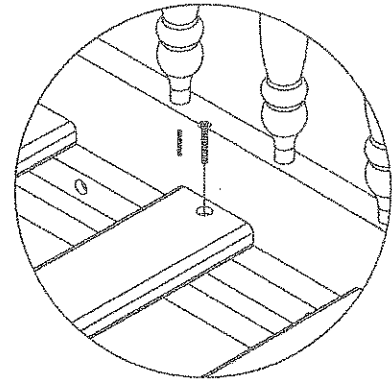
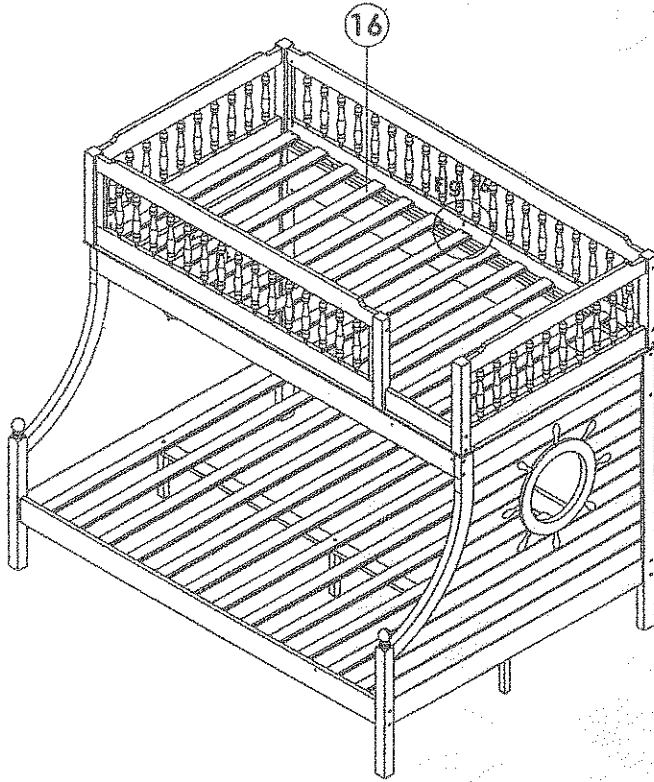



Figure 16

HARDWARE USED IN THIS STEP

I	6		CSK C/B SCREW (M4 X 32MM)
---	---	---	--------------------------------------

STEP 9

1. Attach and secure **Ladder Slats** onto **Ladder Sides** by using **JCBC W Screws (H)**, tighten it up by using an **Allen Key (K)** as shown in **Figure 17**.

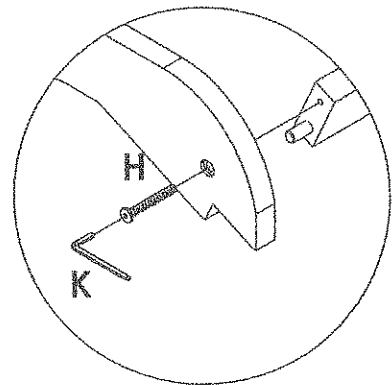
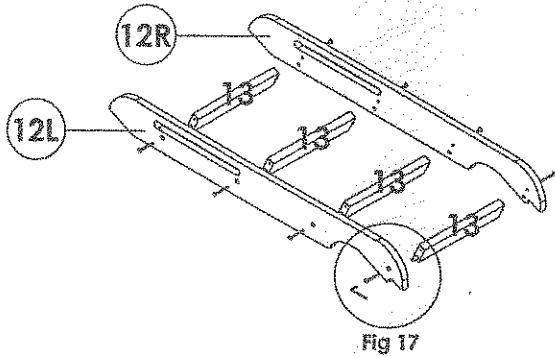



Figure 17

HARDWARE USED IN THIS STEP

H	8		JCBC W SCREW (M7 X 50MM)
K	1		ALLEN KEY (M4 X 60MM)

STEP 10

1. Attach and secure Ladder onto Bottom Bed Front Rail & Bottom Bed Side Rail by using JCBC Bolts (C), tighten it up by using an Allen Key (K) as shown in Figure 18.

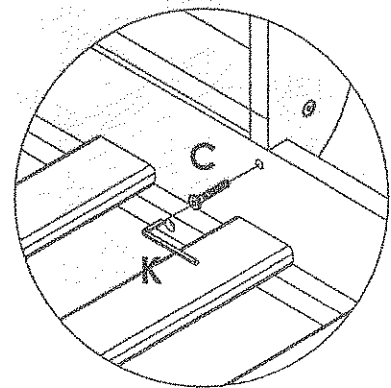
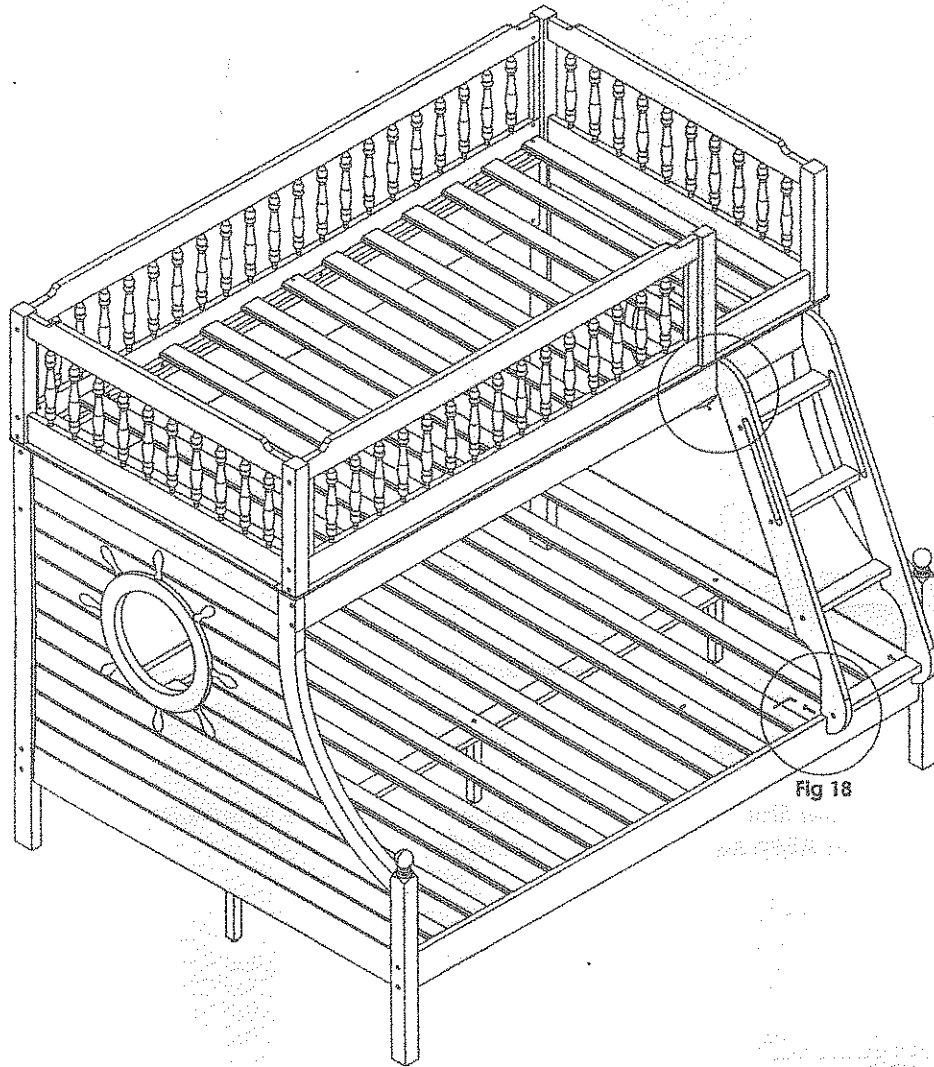

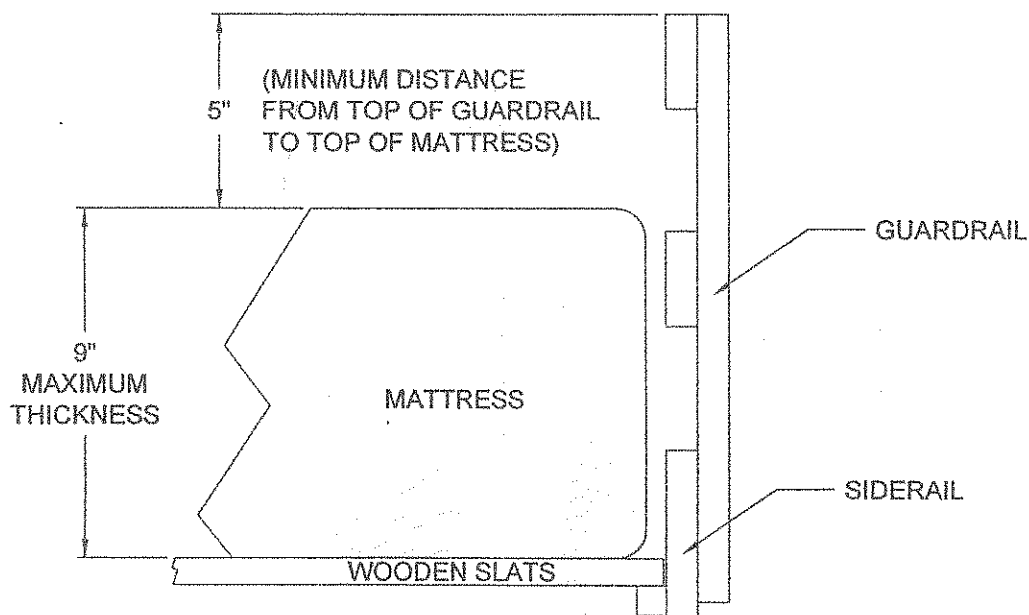

Figure 18

HARDWARE USED IN THIS STEP

C	4		JCBC BOLT (M6 X 35MM)
K	1		ALLEN KEY (M4 X 60MM)

BEDDING SPECIFICATION



MATTRESS SIZE

Upper Bunk Mattress Specification :

- Only use a mattress that is 74" - 75" long and 37 1/2" - 38 1/2" wide on upper bunk.
- Ensure thickness of mattress does not exceed 9".

Lower Bunk Mattress Specification :

- Only use a mattress that is 75" long and 54" wide on lower bunk.
- Ensure thickness of mattress is 10" only.

Replacement parts :

Replacement parts, including additional guard rails, can be obtained from any WASANIAGA distributor or retailer.