

Assembly Instructions

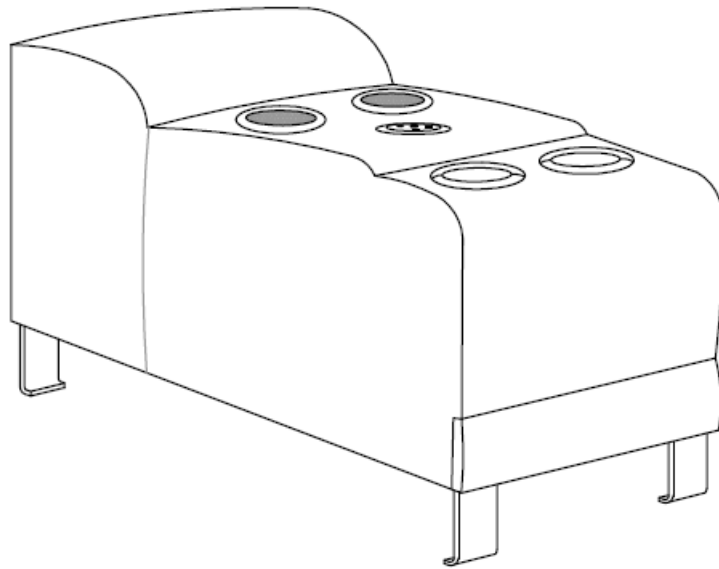

ASSEMBLY RATING

The Assembly Rating is a 5-point system that shows the degree of effort needed in assembling a specific product (with 1 being easy and 5 being difficult). For some products, two persons are recommended.

EASY  DIFFICULT

Tools Required for Assembly:

Allen Wrench



(Included)

Phillips Screwdriver



(Not included)

ASSEMBLY & CARE ADVICE

FOR YOUR FURNITURE TO LAST, CORRECT ASSEMBLY AND PROPER MAINTENANCE ARE NECESSARY. PLEASE FOLLOW THE INFORMATION PROVIDED BELOW TO FULLY ENJOY YOUR FURNITURE.

BASIC ASSEMBLY TECHNIQUES

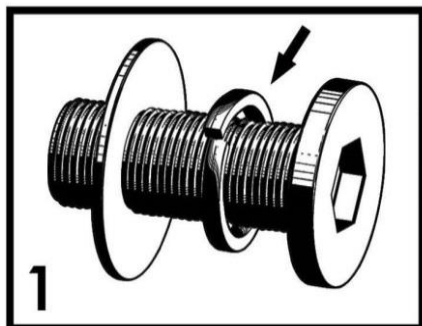

1 When lock or spring washer is used in an assembly, please make sure the lock or spring washer is placed between the larger flat washer and the head of the screw or bolt.

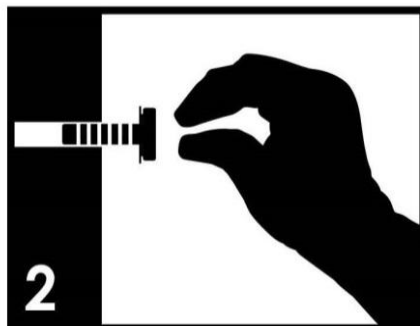

2 Position each part correctly and insert screws or bolts into their respective holes by hand tighten or using the proper hand tool. Only tighten when step is completed or when instructed to do so.

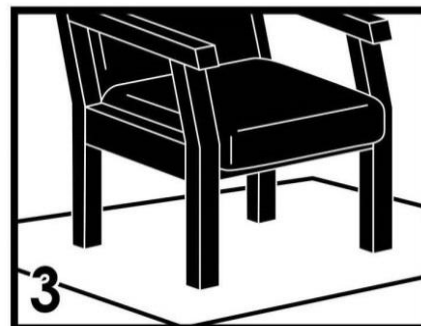

3 Use cardboard or carpet area when assembling furniture to prevent scratches. Make sure the furniture rests on a flat and level surface with each leg evenly touching the floor.

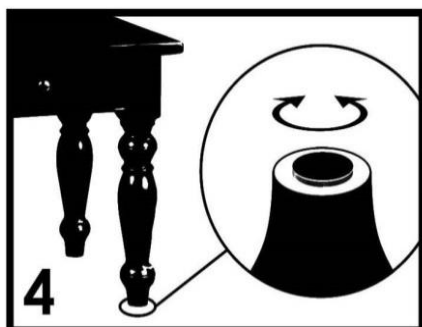

4 Some furniture comes with height adjustment knobs underneath each leg. To lower or to raise each leg, you need to turn clockwise or counterclockwise, respectively.

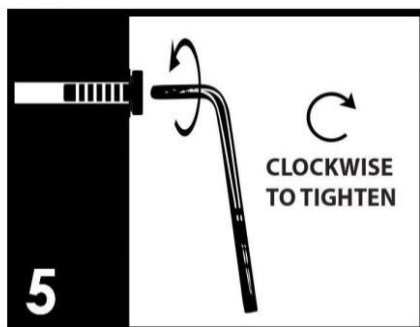

5 Make sure all parts are properly aligned, then use the appropriate hand tool to completely tighten the bolts or screws. Do not use power tools and do not overtighten.

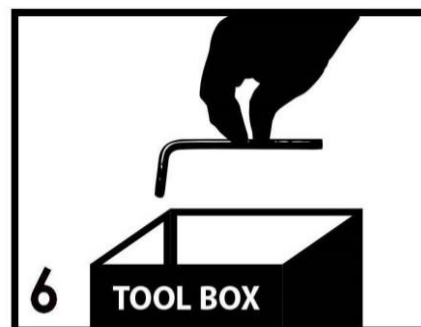

6 Save the instructions and store the Allen wrench or any supplied tool for later maintenance. After two weeks, check and tighten any loose hardware and repeat again every six months thereafter.

IT IS THE USER'S RESPONSIBILITY TO MAINTAIN THE FURNITURE. THE HARDWARE MAY LOOSEN OVER TIME AND MAY CAUSE THE FURNITURE TO BE WOBBLY AND UNABLE TO SUPPORT ITS INTENDED WEIGHT CAPACITY. THIS MAY LEAD TO COLLAPSE AND MAY CAUSE SERIOUS INJURY.



FAILURE TO FOLLOW THE GUIDELINES ABOVE MAY RESULT IN INJURY AND/OR PROPERTY DAMAGE.

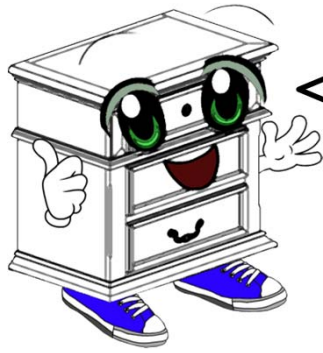

Before you begin, please read Page 2 of "Assembly and Care Advice".

And remember, do not tighten until each step is completed or instructed.

MD

Parts List



#1 x 4 pcs
Leg

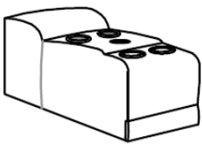

#2 x 1 pc
Console



#3 x 1 pc
Power Adapter

Hardware List



#A x 4 pcs
Bolt 5/16"x1"



#B x 4 pcs
Flat Washer



#C x 1 pc
Allen Wrench



#D x 16 pcs
Wood Screw

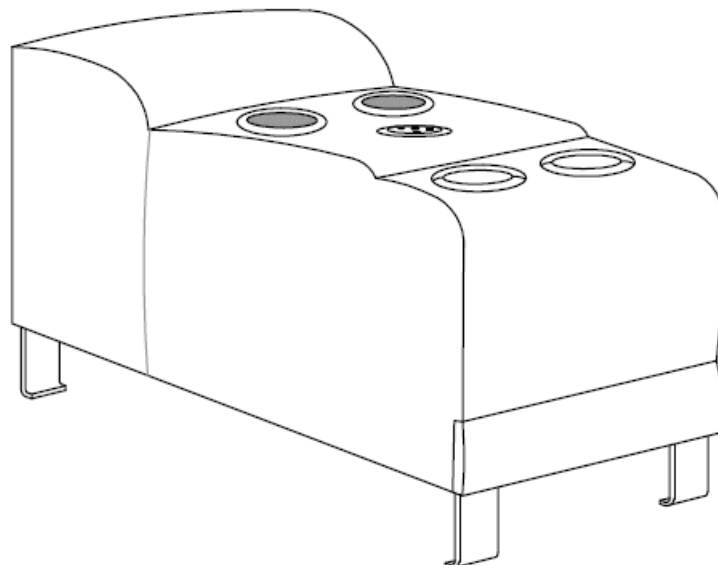



#A x 4 pcs
 #B x 4 pcs
 #D x 16 pcs

- I. Align the 4 legs (#1) with the pre-drilled holes on the bottom corners of the console (#2).
- II. Prepare 4 bolt assemblies by inserting the flat washer (#B) onto the bolt (#A).
- III. Insert the bolt assemblies through the 4 legs (#1) using the Allen wrench (#C) to lock them with the console (#2).
- IV. Insert 4 wood screws (#D) through each leg (#1) using the Phillips screwdriver to lock them with the console (#2).

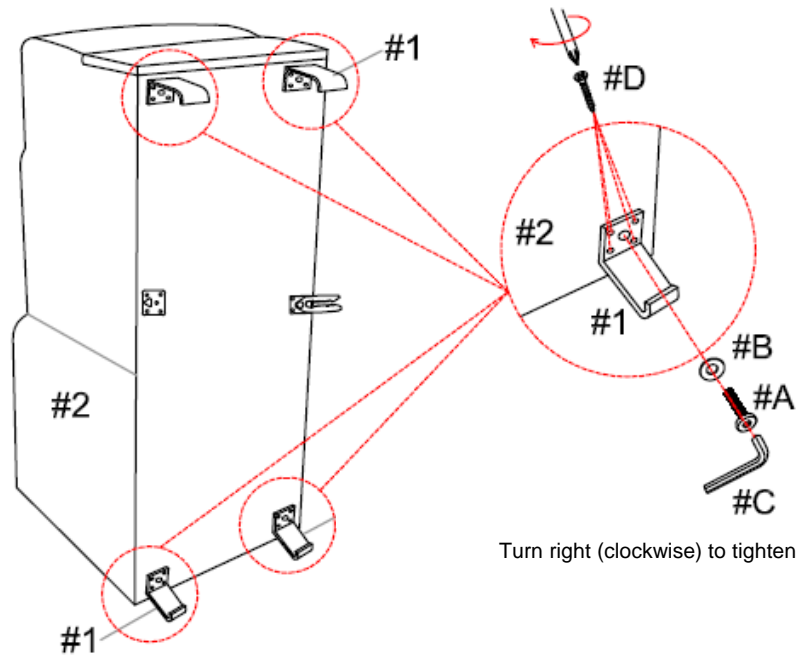

- I. Make sure the console is rested on a flat surface and does not feel loose or wobbly. If it does, double check that the bolts/screws are secured and properly tightened.
- II. To supply power to the unit, plug the metal prongs of the power adapter (#3) into the AC wall outlet and the barrel pin connector to the connection port of the console (#2).

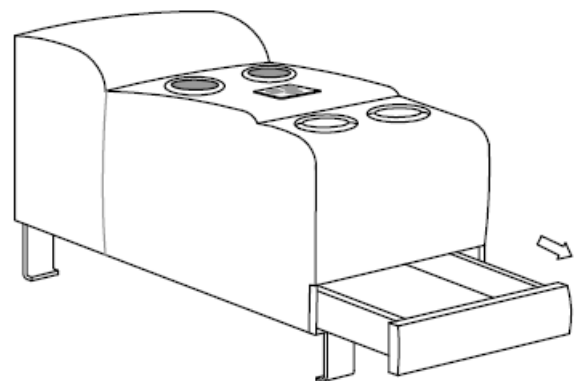
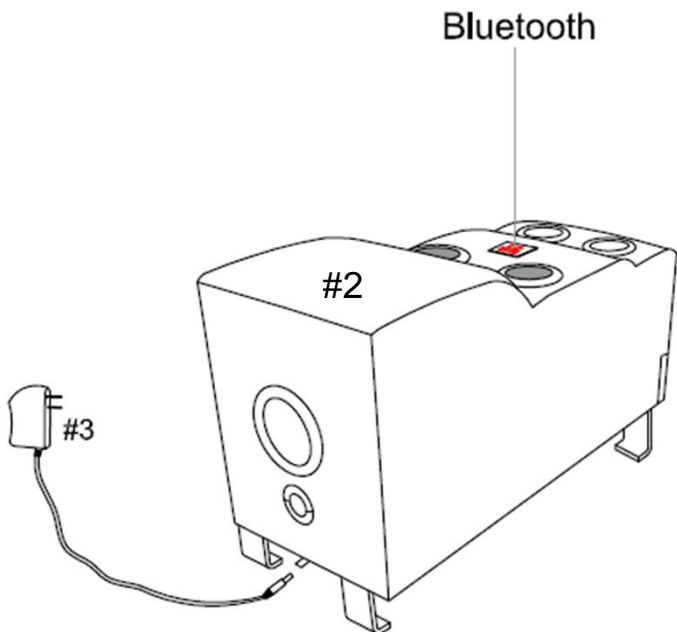



Connect the console to the sofa and chaise together as shown below by locking the male brackets with the female brackets.

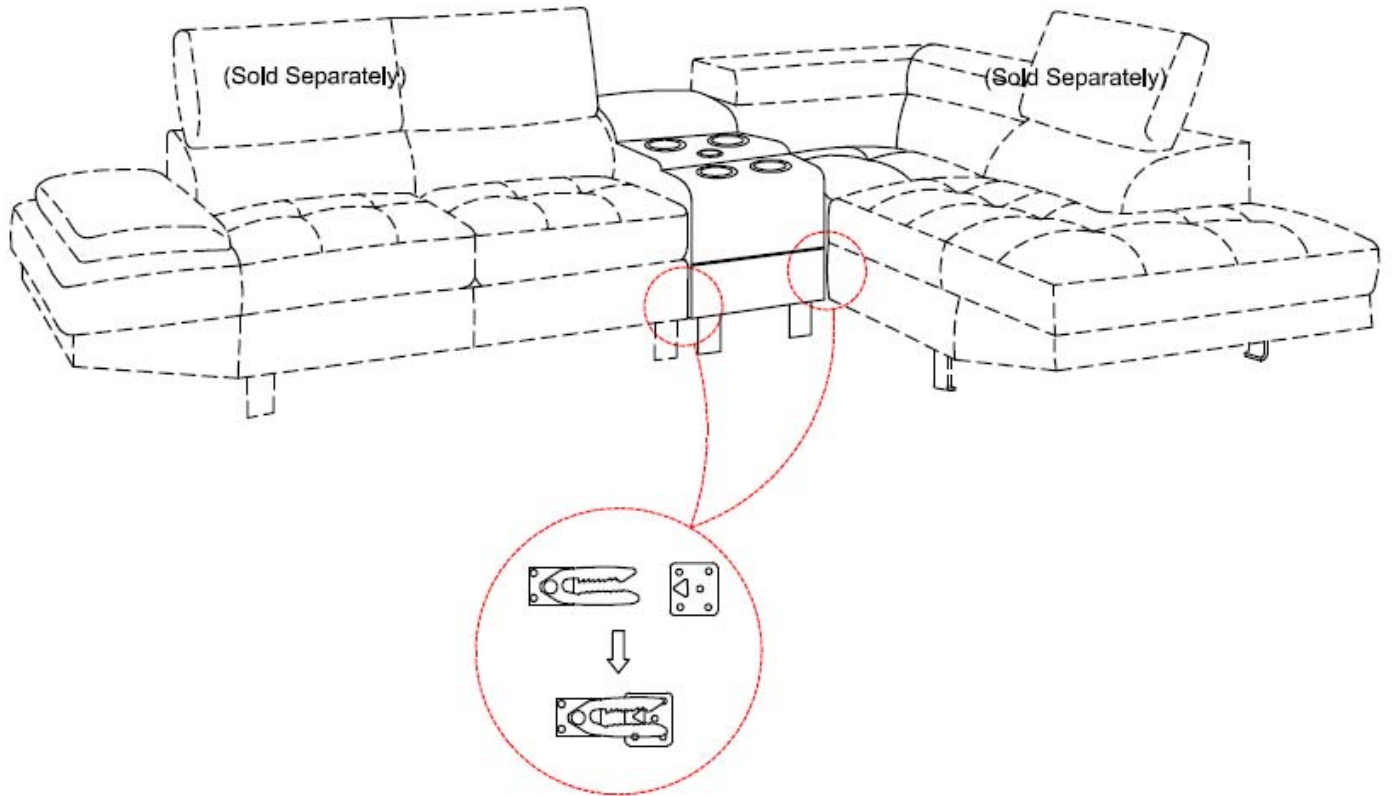

ASSEMBLY IS COMPLETED