

# ASSEMBLY INSTRUCTION (Instructions de montage)

N752P436722

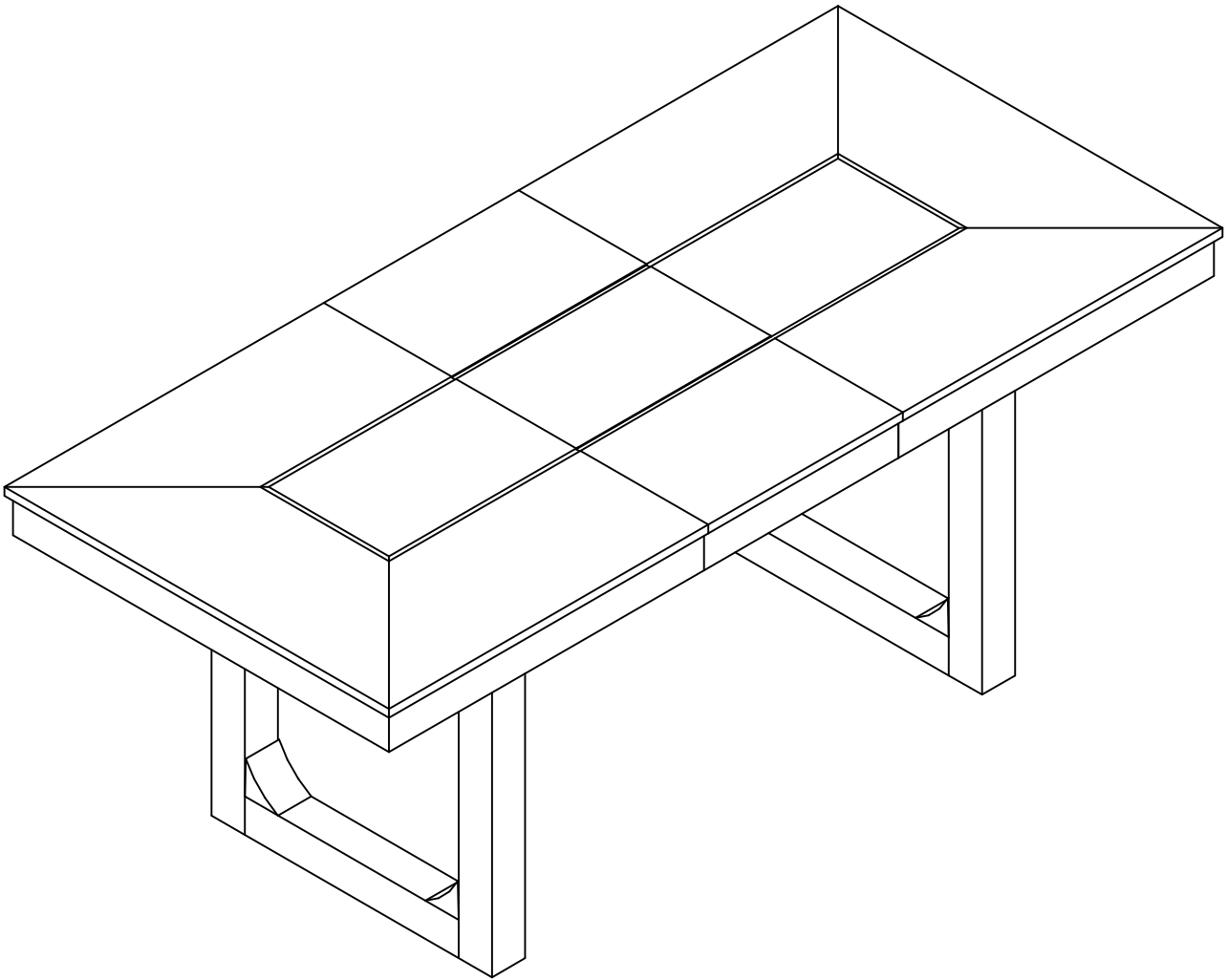

NOTE: 50% TIGHTEN BEFORE FIXING ALL BOLTS  
(REMARQUE: SERRER À 50% AVANT DE FIXER TOUS LES BOULONS)

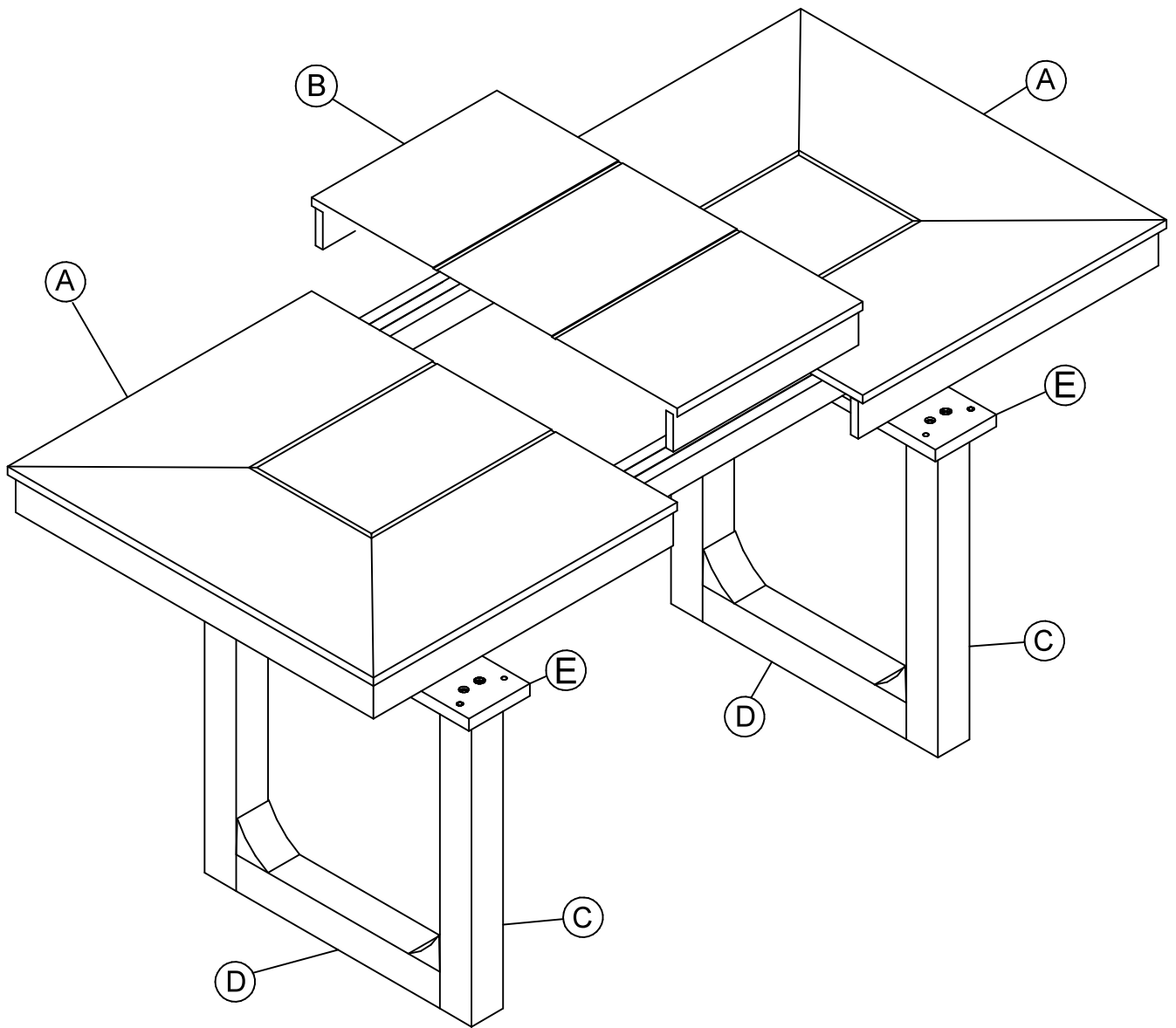

**Notice:**

1. Tighten all screws to approximately 50% before final tightening.
1. Serrez toutes les vis à environ 50 % avant le serrage final.
2. Place the item on a flat, stable surface during assembly.
2. Placez le produit sur une surface plane et stable pendant l'assemblage.
3. Gradually tighten all screws using the appropriate tools.
3. Serrez progressivement toutes les vis en utilisant les outils appropriés.
4. If the screws are not aligned with the holes during assembly, loosen all other screws to 50% and continue the assembly process.
4. Si les vis ne s'alignent pas avec les trous pendant l'assemblage, desserrez toutes les autres vis à 50 % et poursuivez l'assemblage.
5. If the item is unstable, loosen all screws, adjust it on a flat surface, and then tighten all screws again.
5. Si l'article est instable, desserrez toutes les vis, ajustez-le sur une surface plane, puis serrez de nouveau toutes les vis.
6. Note: If one or more screws are fully tightened during assembly, the other screws may not align with the holes. Additionally, all holes are intentionally designed to be slightly larger to provide more space for screw adjustments.
6. Remarque : Si une ou plusieurs vis sont complètement serrées pendant l'assemblage, les autres vis peuvent ne pas s'aligner avec les trous. De plus, tous les trous sont intentionnellement conçus pour être légèrement plus grands afin de permettre un meilleur ajustement des vis.

# PART LIST ( LISTE DES PIÈCES)

**A**

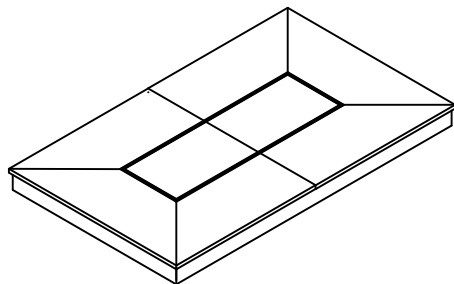

Tabletop (1pc)  
(Plateau de table)

**B**

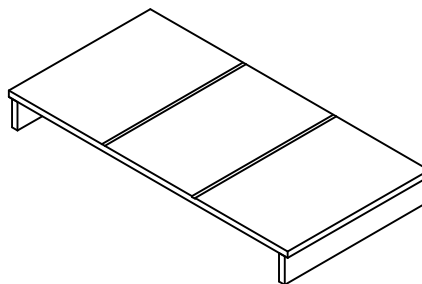

Leaf Panel (1pc)  
(Panneau d'extension)

**C**

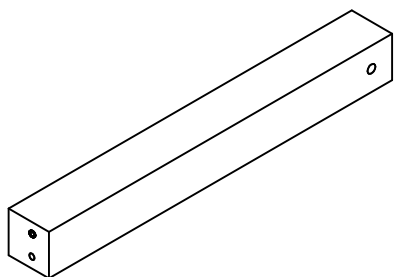
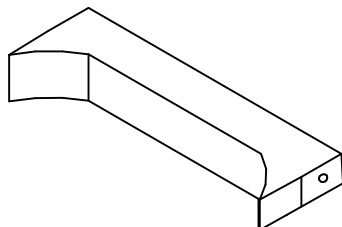

Table Leg (4pcs)  
(Pied de table)

**D**



Stretchers (2pcs)  
(Entretoises)

**E**

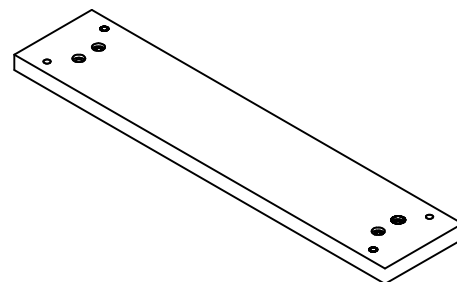

Connection Panel (2pcs)  
(Panneau de connexion)

# HARDWARE LIST (LISTE DU MATÉRIEL)

**1**

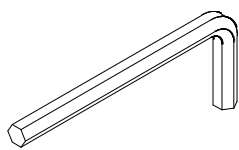

Allen key 4mm (1pc)  
(Clé allen)

**2**

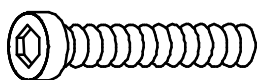

Bolt 5/16"x45mm (20pcs)  
(Boulon)

**3**



Lock washer Ø5/16" (16pcs)  
(Rondelle élastique)

**4**

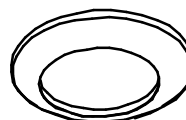

Flat washer Ø5/16"\*Ø19mm  
(16pcs)  
(Rondelle plate)



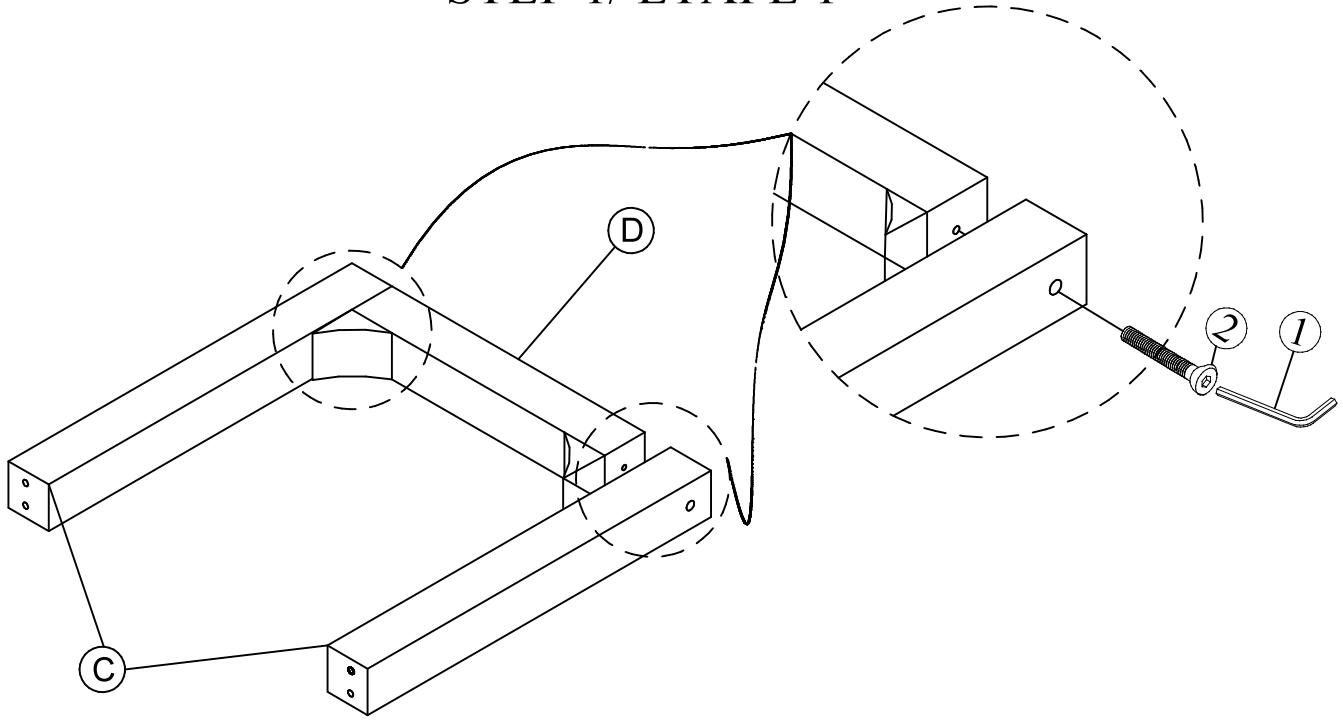

## STEP 1/ ÉTAPE 1

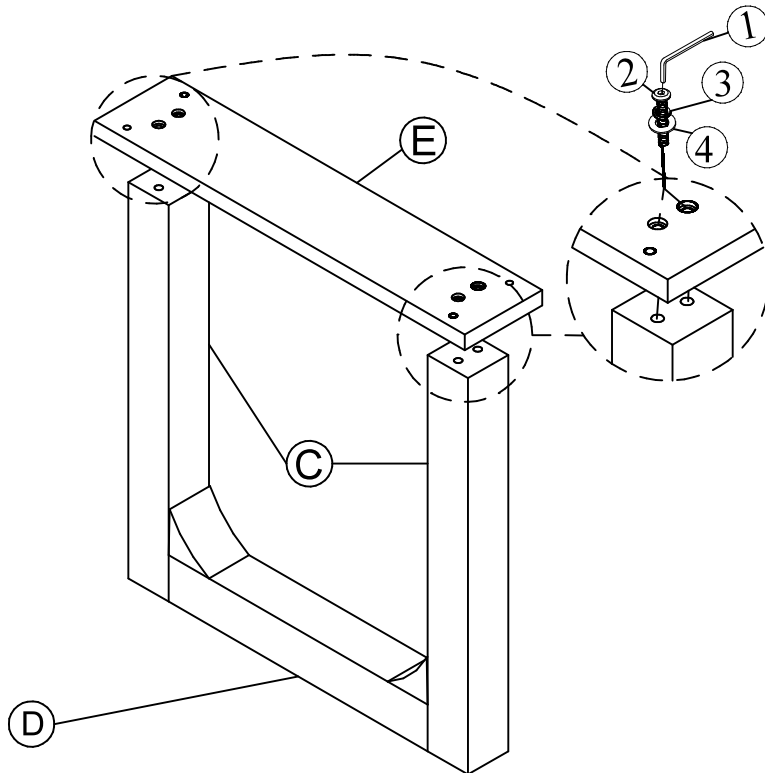

1		Allen Key 4mm (Clé Allen)	1pc	2		Bolt 5/16"x45mm (Boulon)	4pcs
---	---	---------------------------	-----	---	--	--------------------------	------

## STEP 2/ ÉTAPE 2

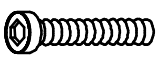

1		Allen Key 4mm (Clé Allen)	1pc	3		Lock washer Ø5/16" (Rondelle élastique)	8pcs
2		Bolt 5/16"x45mm (Boulon)	8pcs	4		Flat washer Ø5/16"*Ø19mm (Rondelle plate)	8pcs

### STEP 3/ ÉTAPE 3

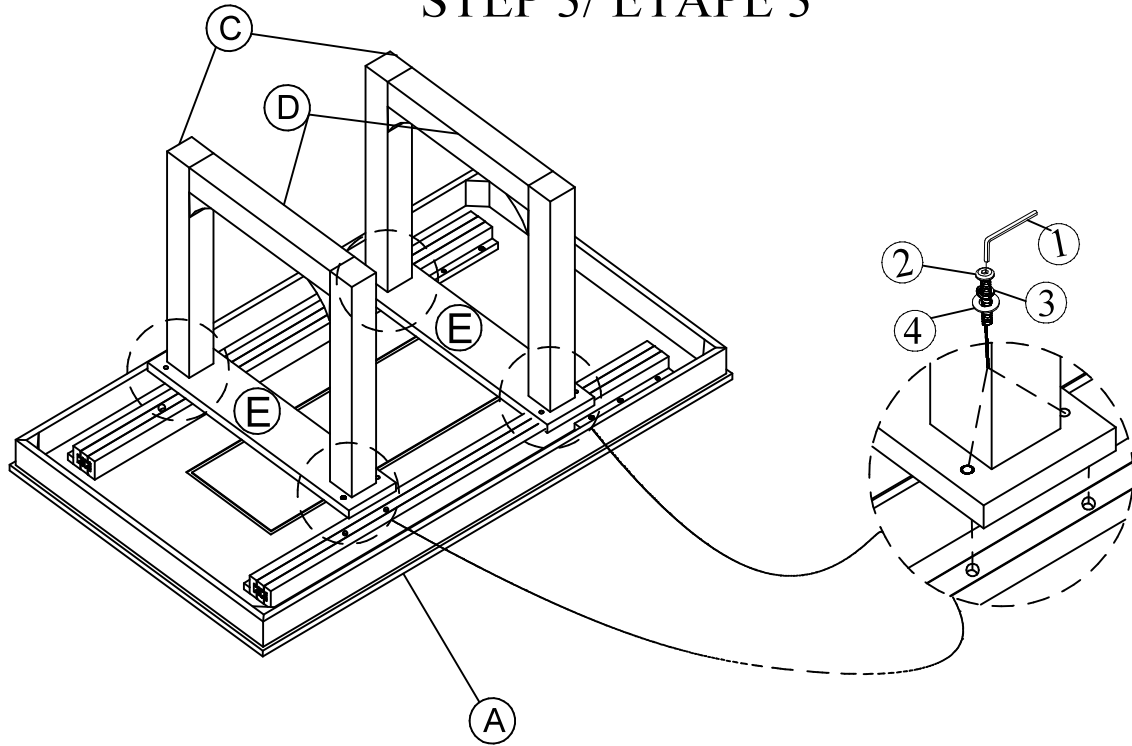

1		Allen Key 4mm (Clé Allen)	1pc	3		Lock washer Ø5/16" (Rondelle élastique)	8pcs
2		Bolt 5/16"x45mm (Boulon)	8pcs	4		Flat washer Ø5/16"*Ø19mm (Rondelle plate)	8pcs

### STEP 4/ ÉTAPE 4

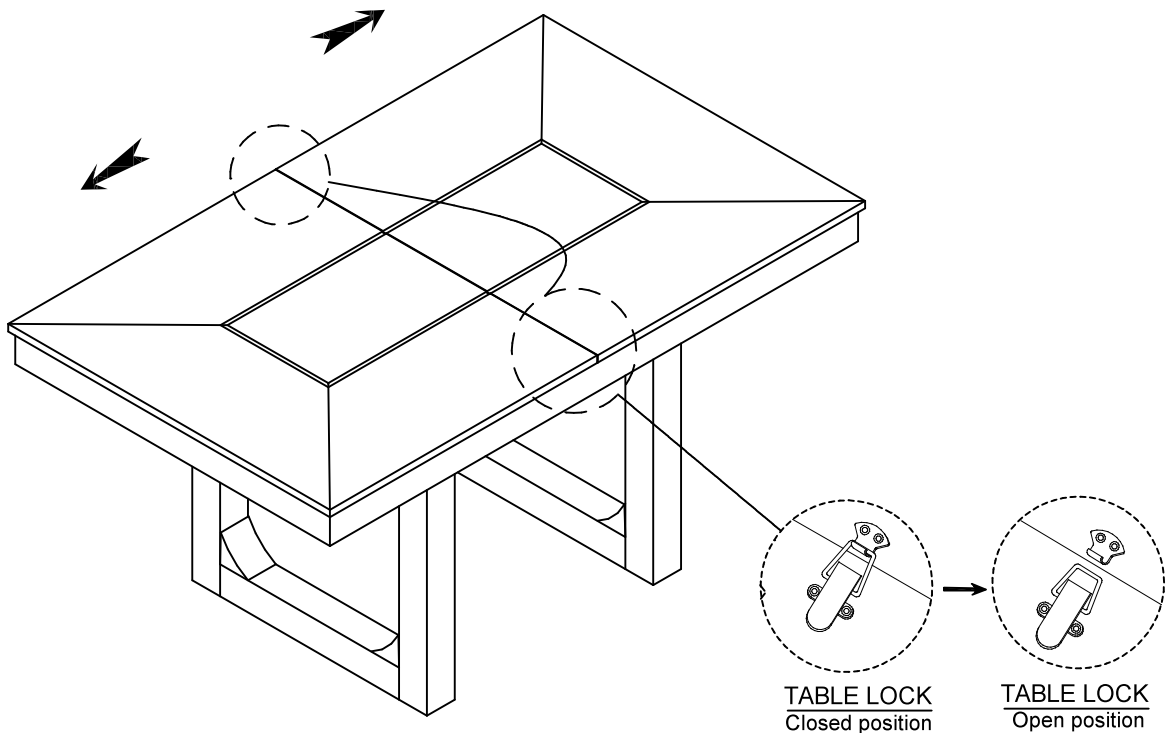

## STEP 5/ ÉTAPE 5

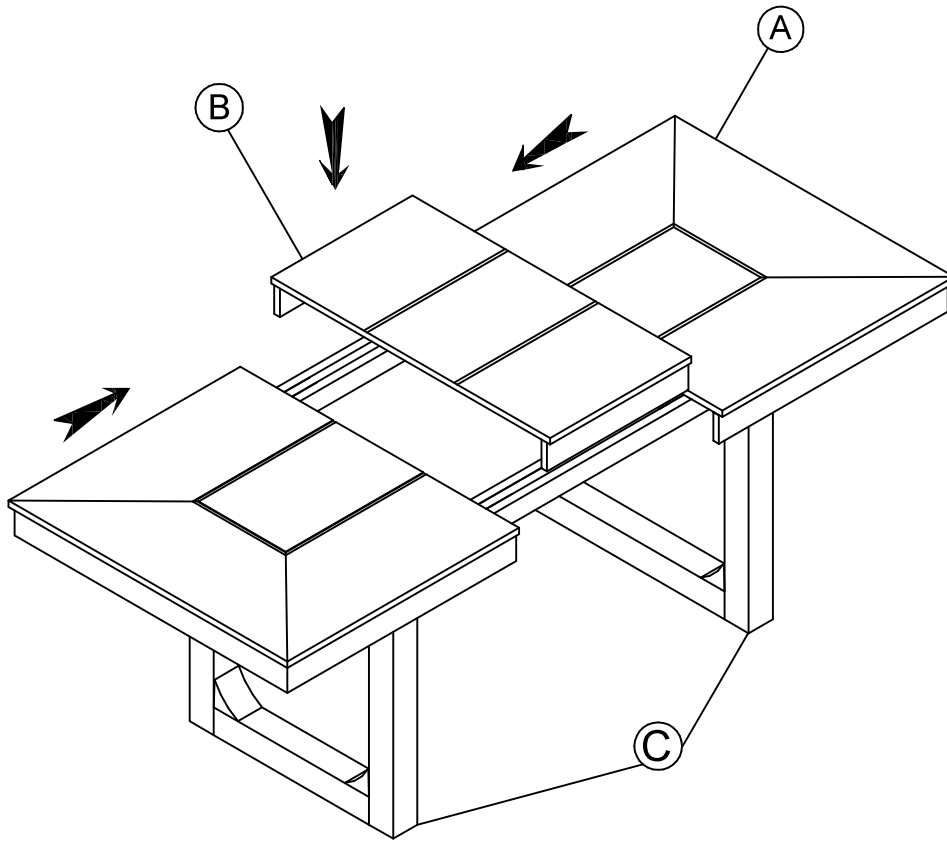

## STEP 6/ ÉTAPE 6

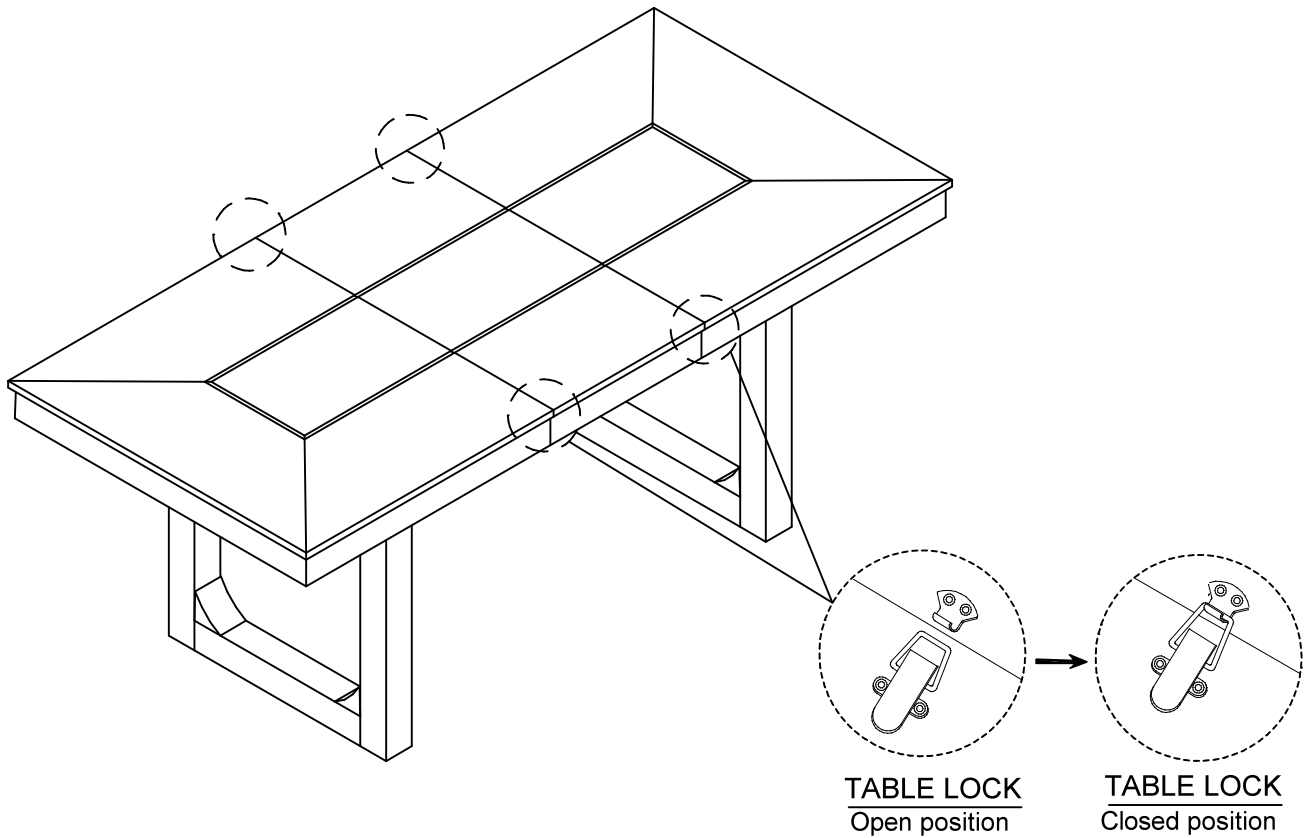

STEP 7/ ÉTAPE 7

