

Assembly Instructions

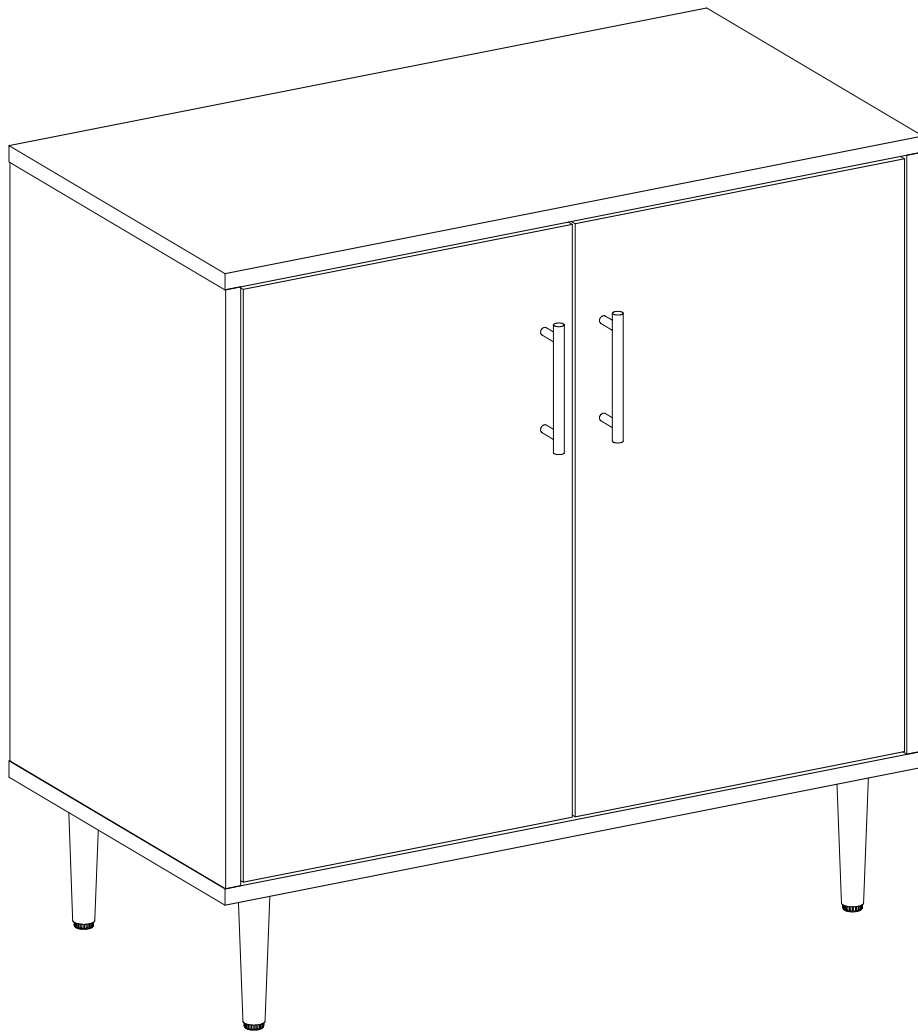

General Assembly Guidelines

- I. Ensure that all parts and hardware are available before beginning assembly.
- II. Follow each step carefully to ensure the proper assembly of this product.
- III. Two people are recommended for ease in the assembly of this product.
- IV. The three main types of hardware used to assemble this product are: wood dowels, screws and bolts.
- V. The provided glue is to secure wood dowels in place. When first inserting dowels, locate the appropriate hole for the dowel, place a small amount of glue in the hole and insert the dowel. Wipe away excess glue immediately.

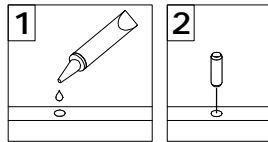

In future assembly steps when dowels are necessary to attach assembly parts together, place a small amount of glue on the end of the dowel before attaching parts together. Wipe away excess glue immediately.

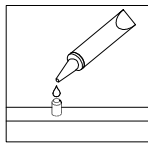

- VI. A Phillips head screwdriver is required for the assembly of this product .

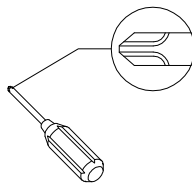

- VII. Power tools should not be used to assemble this product.

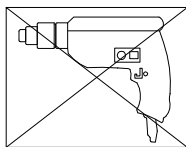





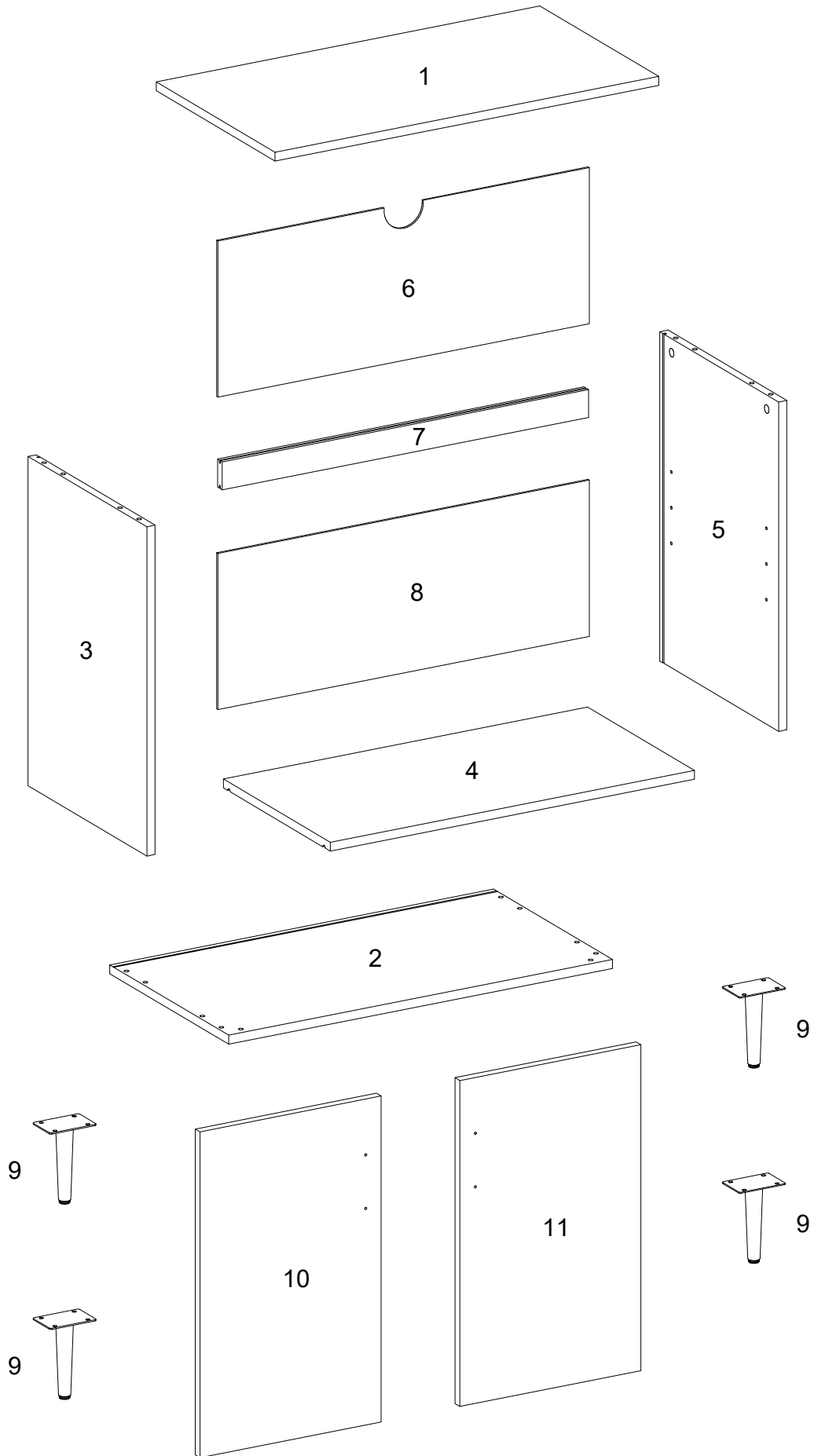







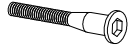





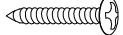

- VIII. Drill may be needed for securing product to wall.

Parts List

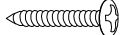
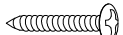

Hardware List

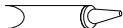
A		Ø8x30mm	Wooden dowel	8 pcs
B		Ø6x35mm	Cam bolt	4 pcs
C		Ø15x11mm	Cam lock	4 pcs
D		Ø30mm	Sticker	4 pcs
E		Ø6x50mm	Bolt	4 pcs
F		M 4	Hex Key	1 pc
G		Ø6x12mm	Bolt	16 pcs
H			Shelf support pin	4 pcs
J			Handle	2 pcs
K		Ø4x22mm	Handle Bolt	4 pcs
L		Ø3x15	Screw	3 pcs
M			Door Hinge	2 pcs
N			Door Hinge	2 pcs
P		Ø3x17	Screw	8 pcs
Q			Plastic wedge	8 pcs
R			Magnetic touch	1 pc
S			Plastic pivot	4 pcs
T			Bolt	2 pcs
U		Ø3x12	Screw	8 pcs
V		Ø3x32	Screw	1 pc
W			Plastic strap	1 pc
X			Nut	1 pc
Y			Glue tube	1 pc

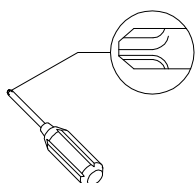

Philips head screwdriver required for assembly
(not included)

*The hardware quantities listed above are required for proper assembly.
Some extra hardware may also have been included.*

Step 1

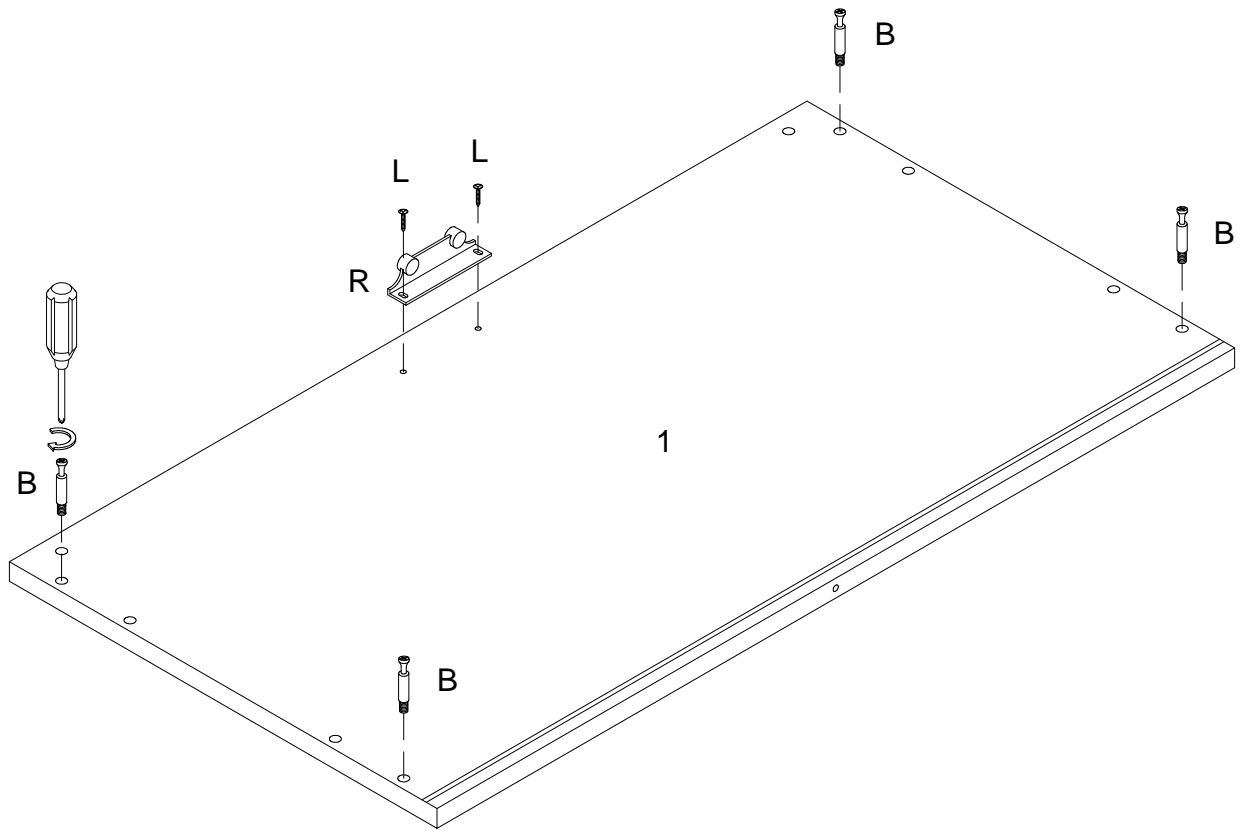

Using cam bolt (B) secure part (1) ,then using screw (L) secure magnetic touch (R) to part (1) with Philips head screwdriver as per diagram.

Step 2

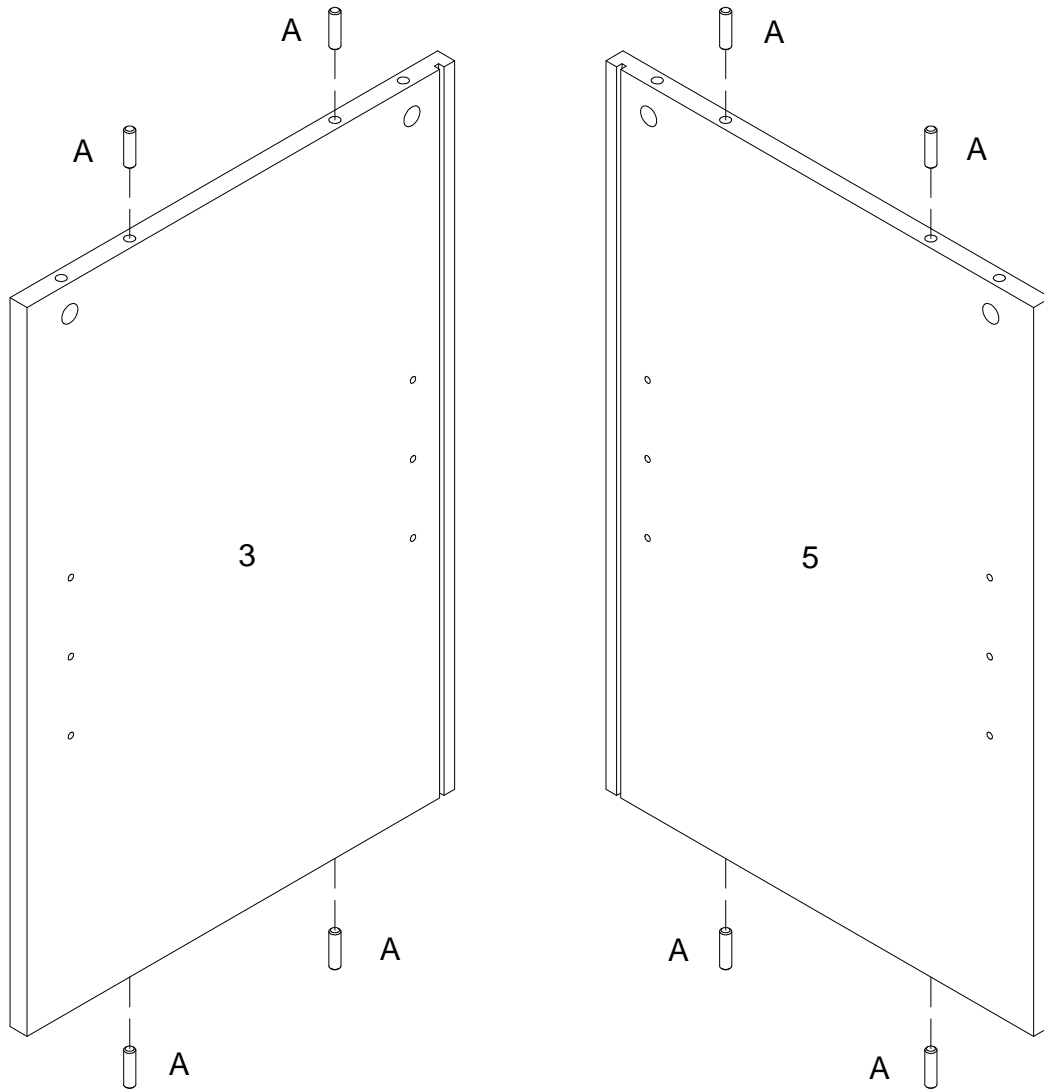

Insert wooden dowel (A) into parts (3,5) .

Step 3

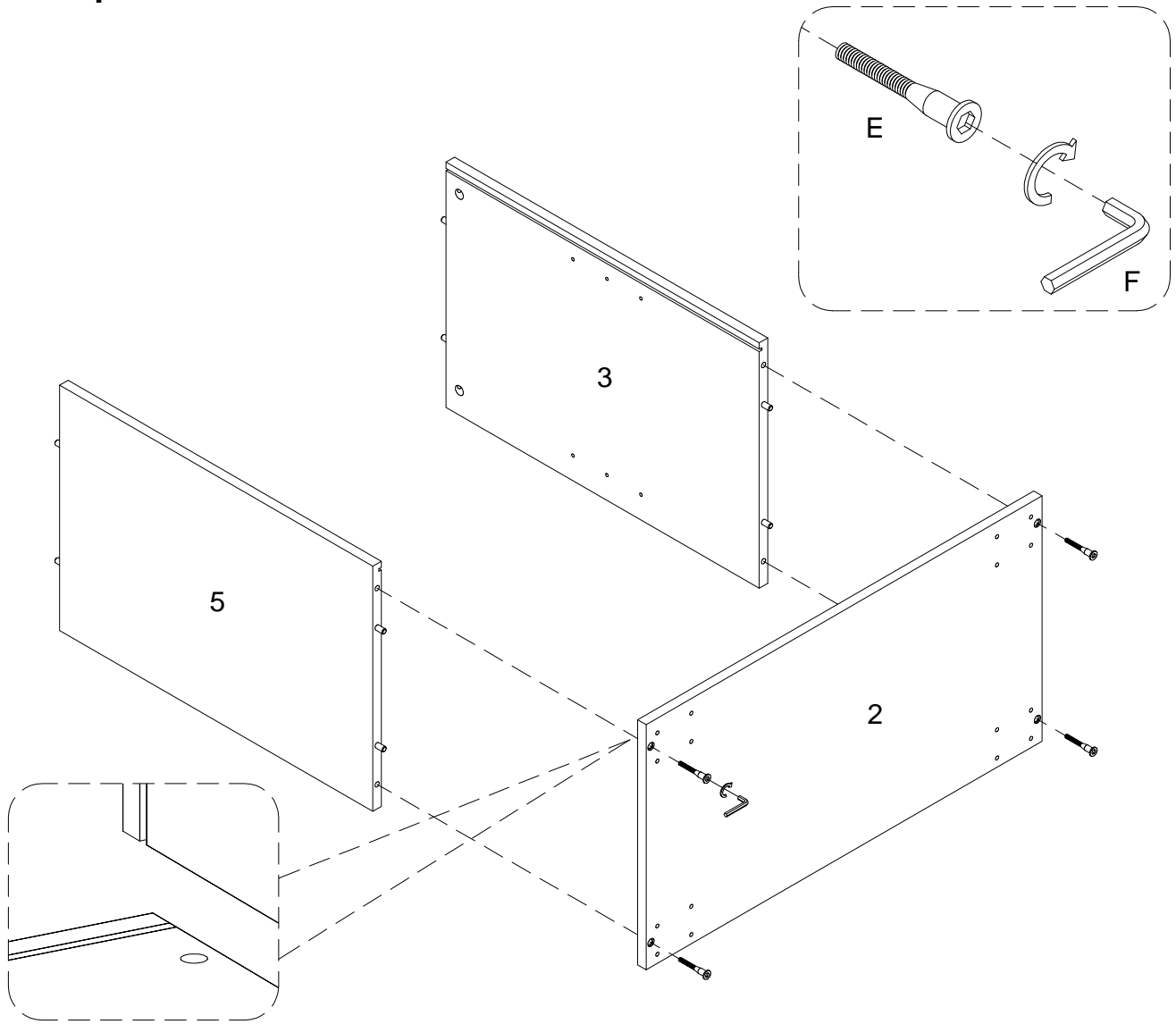

Using bolt (E) secure part (2) into parts (3,5) with hex key (F) as per diagram.

Step 4

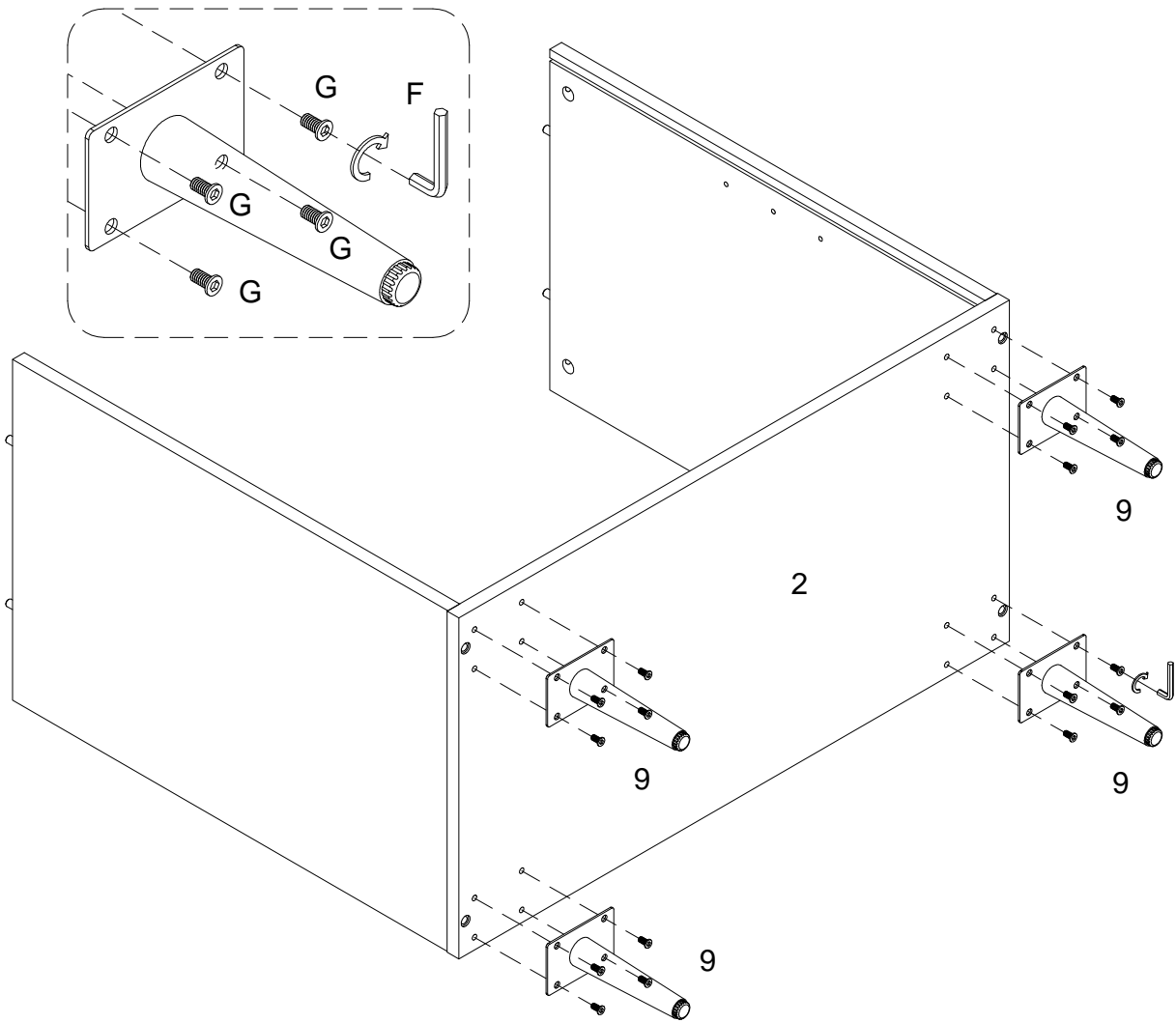

Using bolt (G) secure part (9) into part (2) with hex key (F) as per diagram.

Step 5

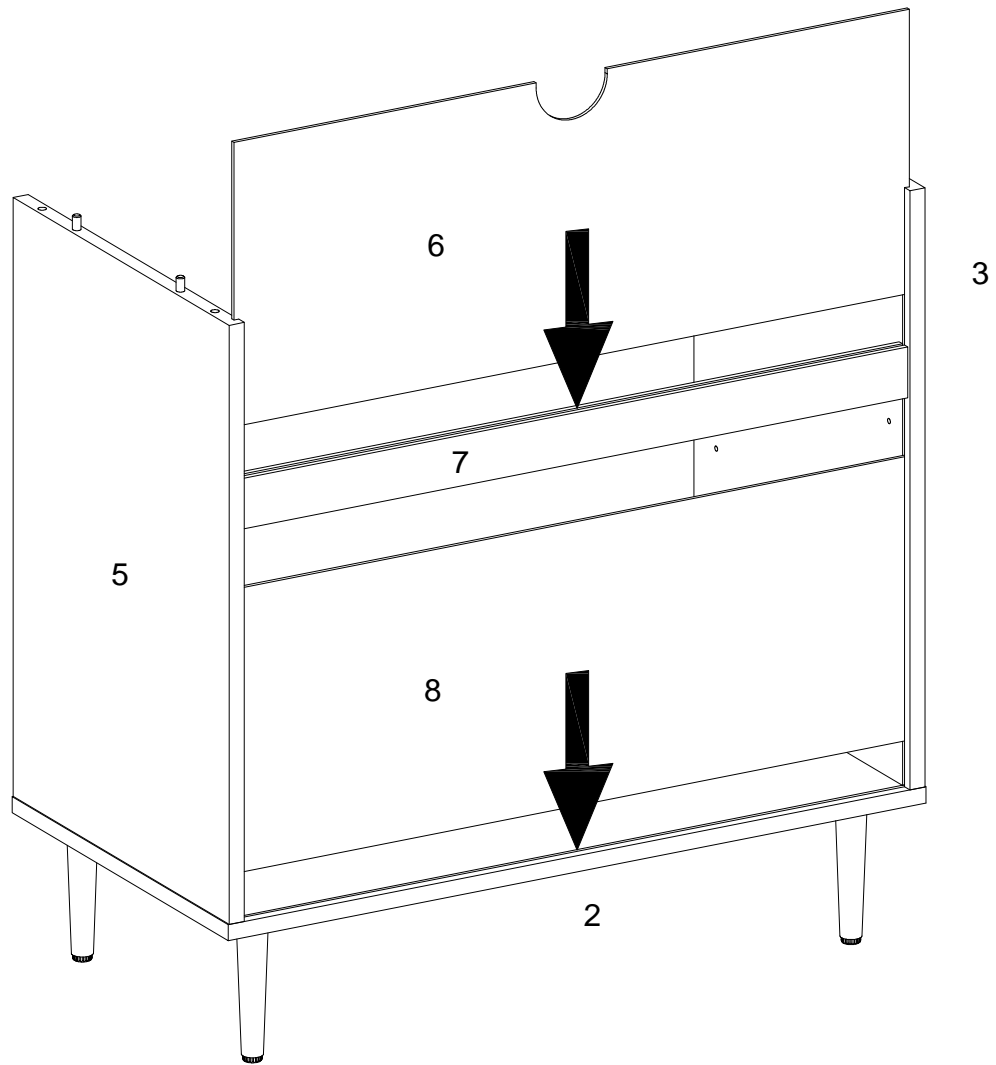

Put parts (6,8) into parts (2,3,5,7) as per diagram.

Step 6

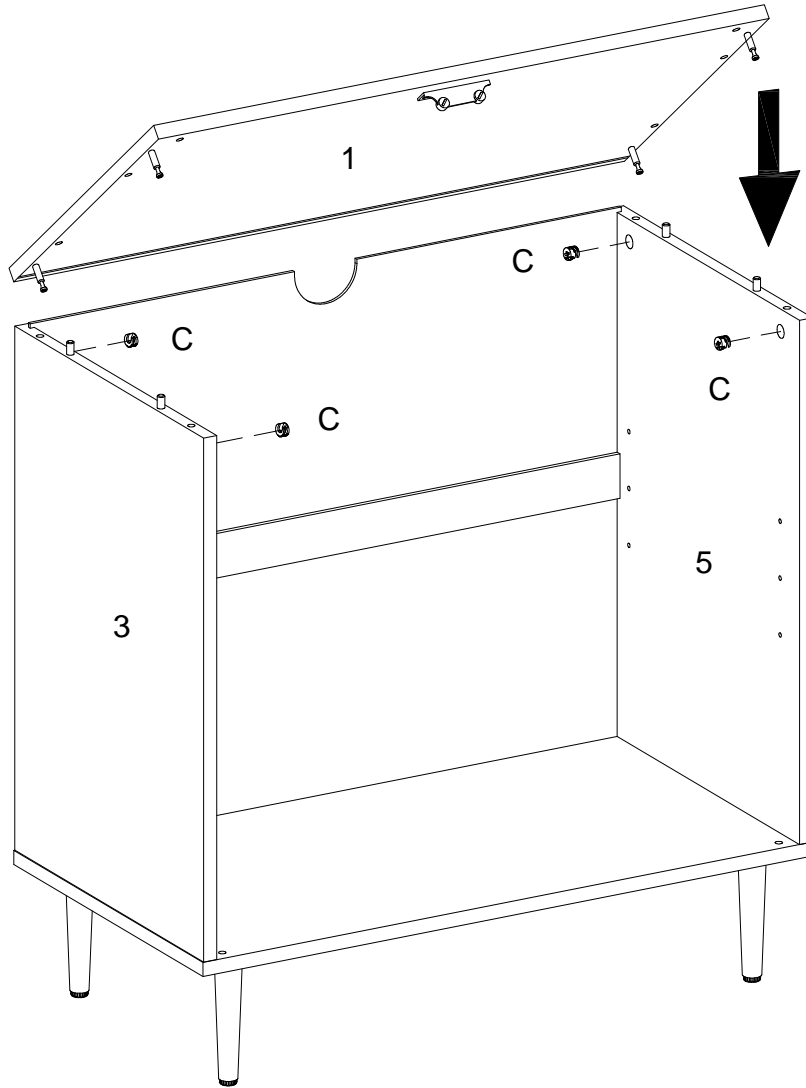
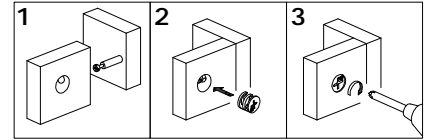

Using cam lock (C) secure part (1) into parts (3,5) with Philips head screwdriver as per diagram.

Step 7

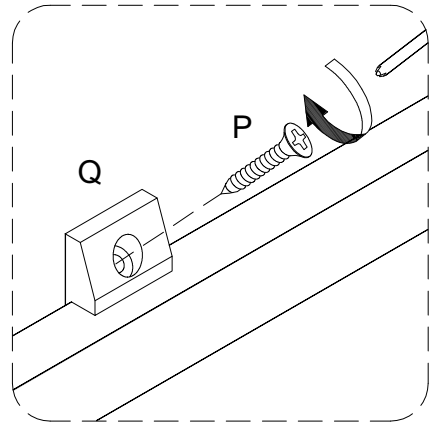
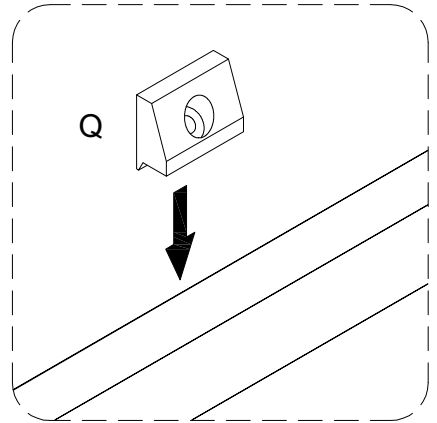
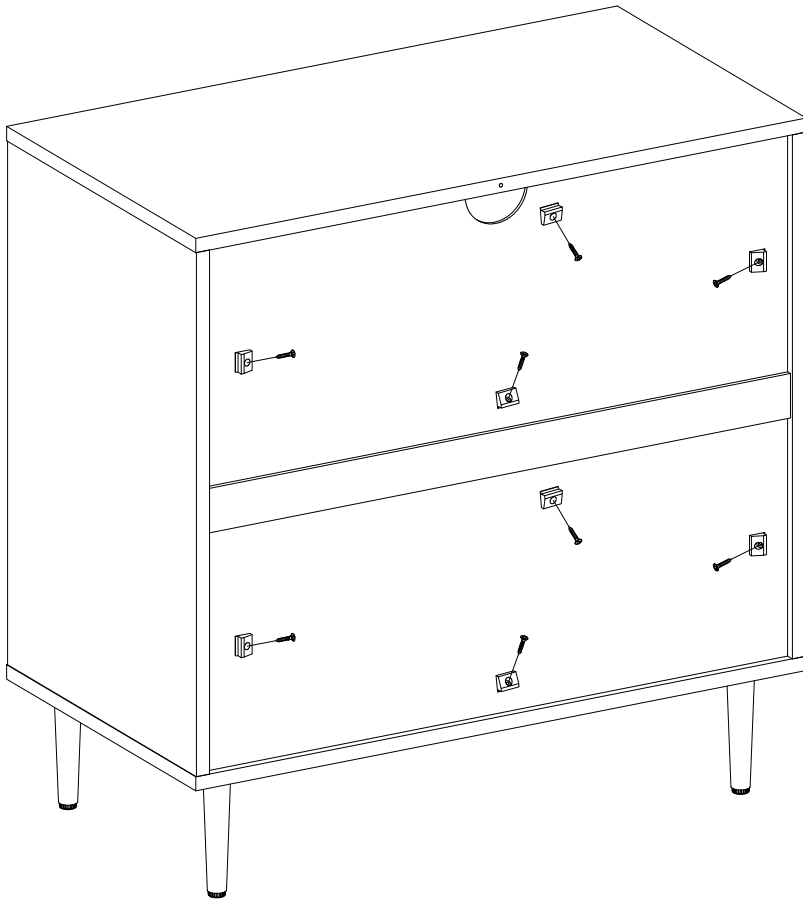

Using screw (P) secure plastic wedge (Q) with Philips head screwdriver as per diagram.

Step 8

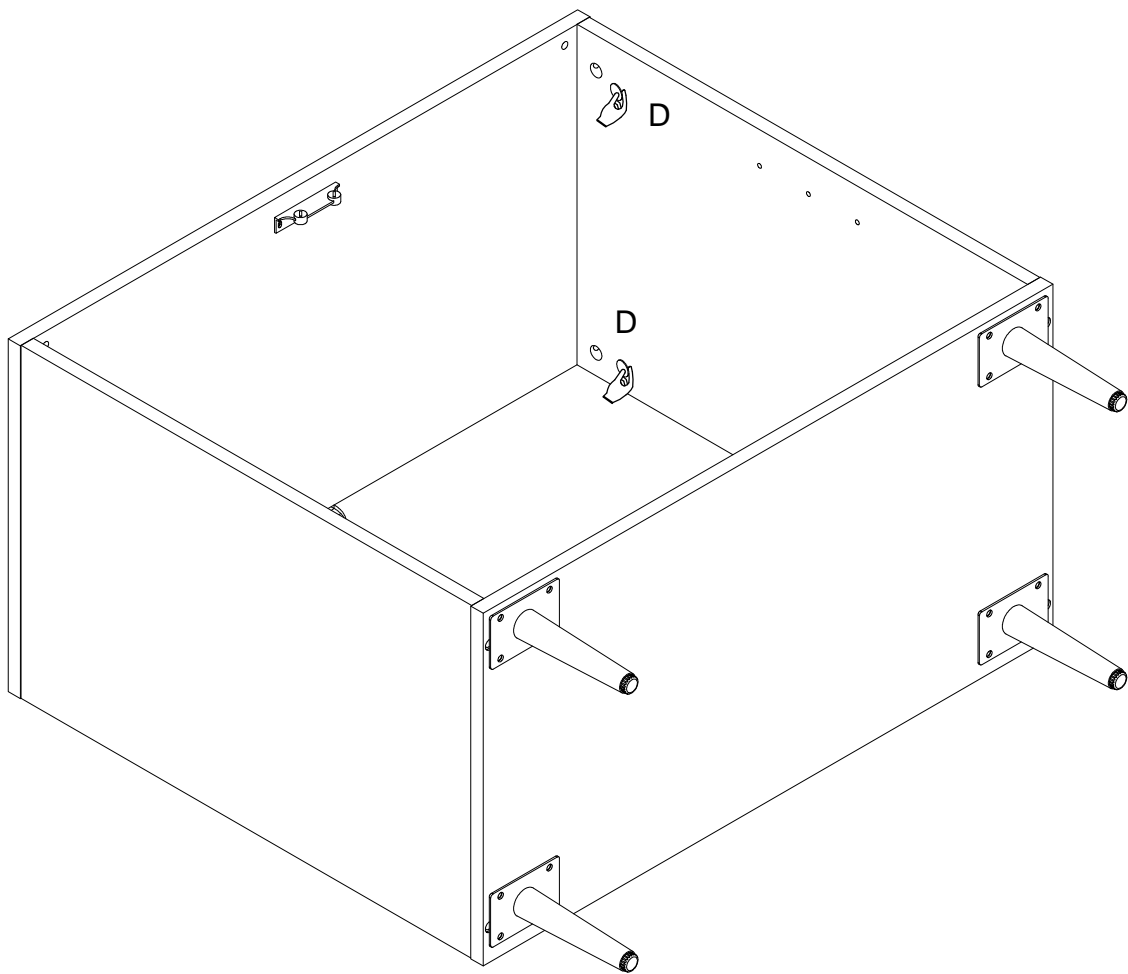

Place sticker (D) cover the holes as per diagram.

Step 9

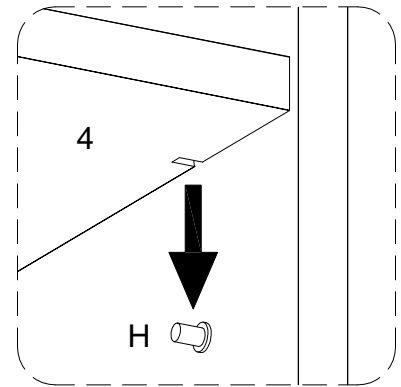
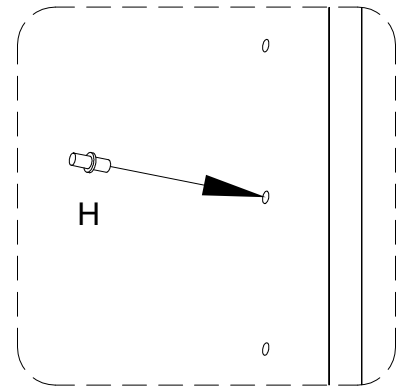
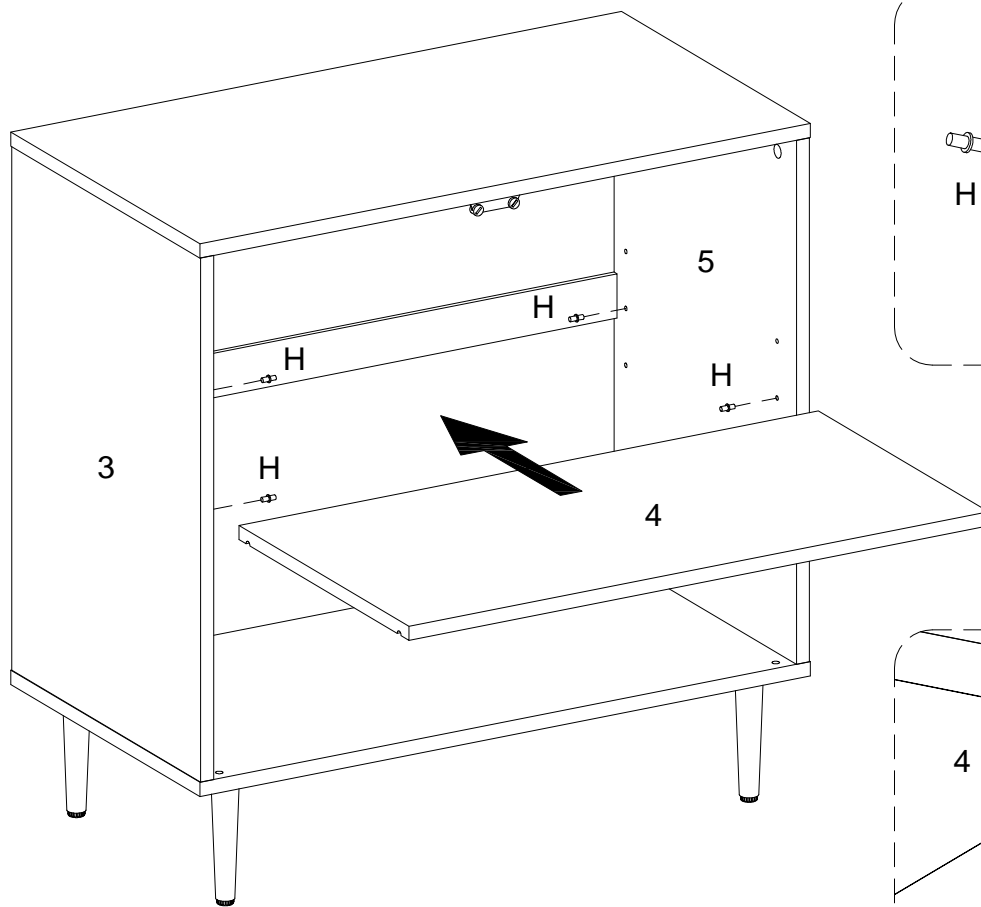

Insert shelf support pin (H) into parts (3,5),then place shelf (4) on the top of support pin as per diagram.

Step 10

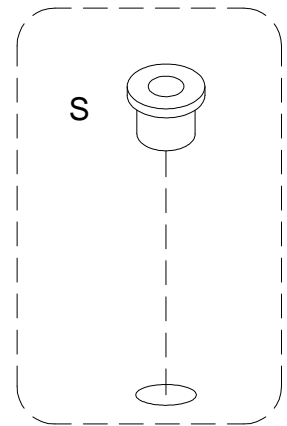
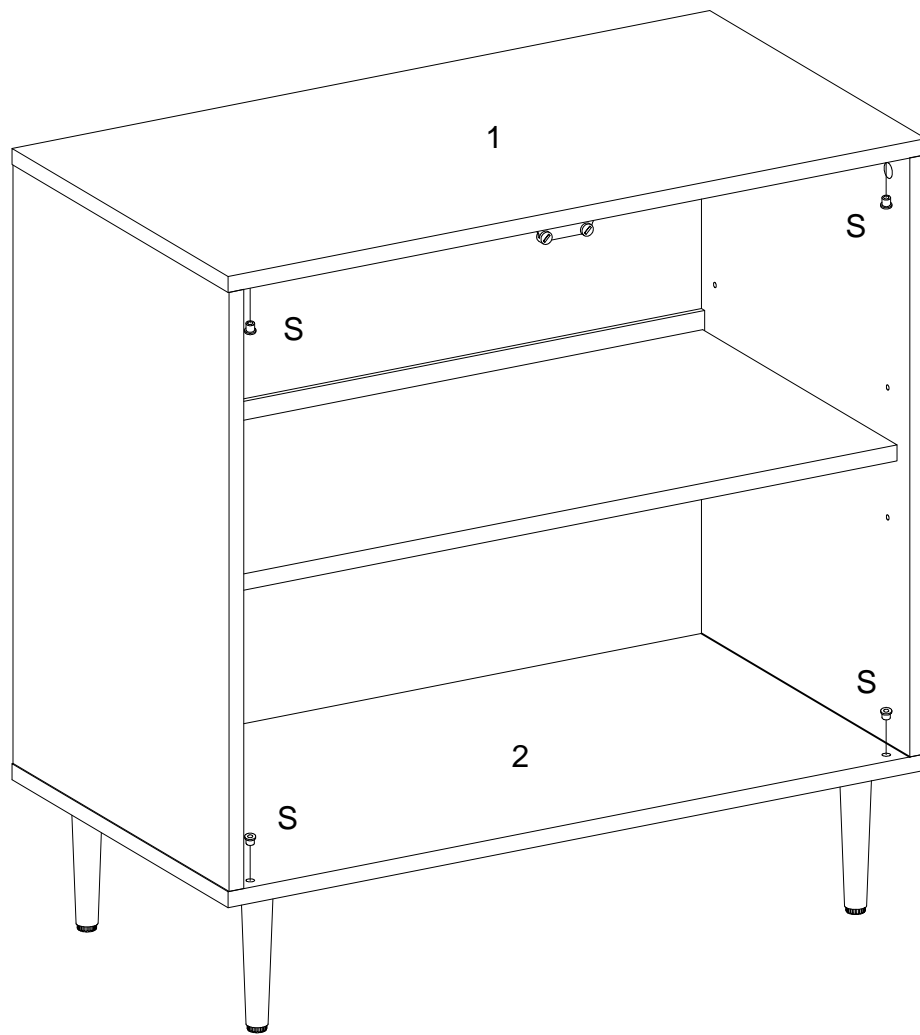

Put plastic pivot (S) into parts (1,2) as per diagram.

Step 11

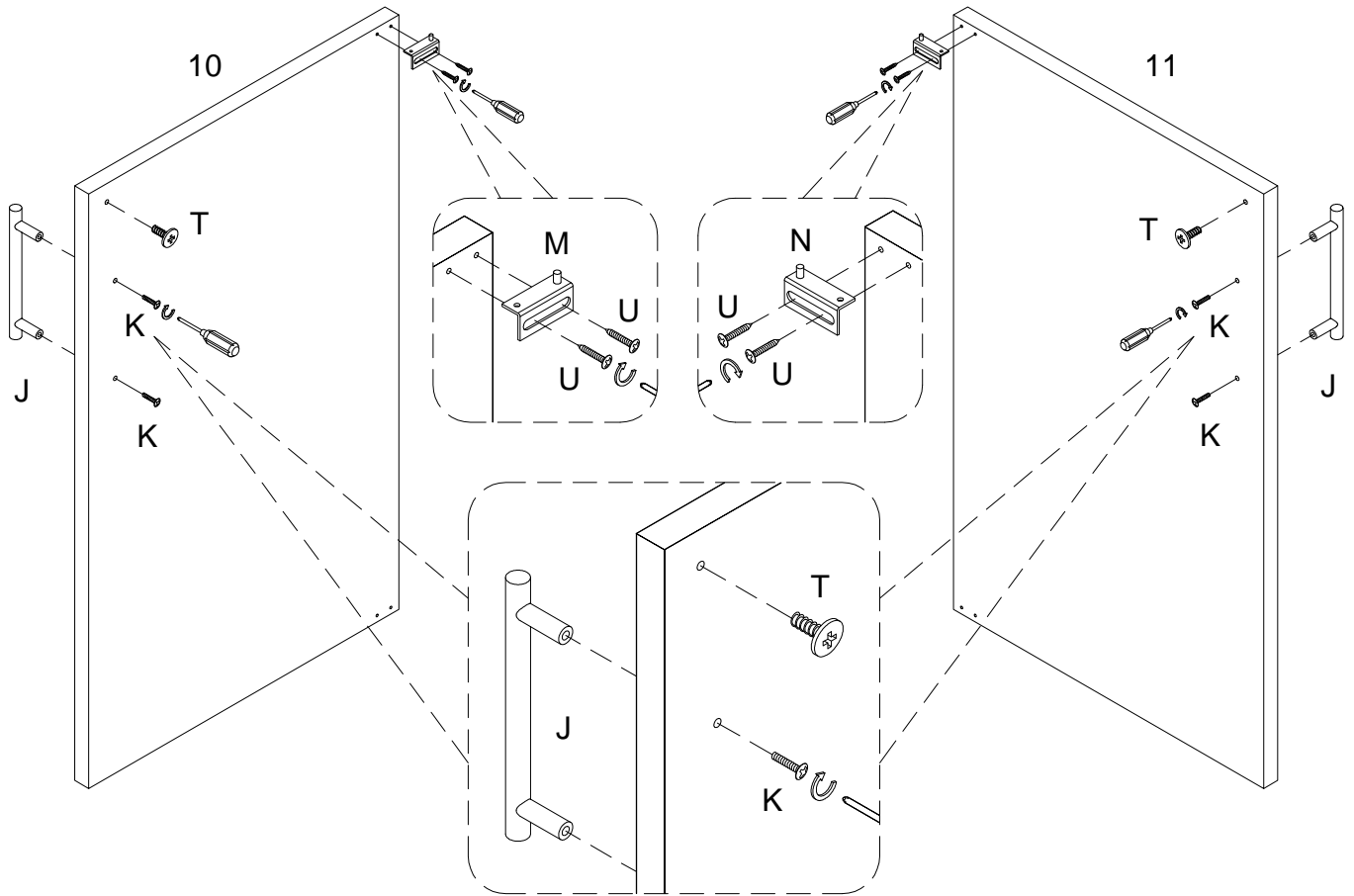

Using bolt (T) secure parts (10,11) ,then using handle bolt (K) secure handle (J) to parts (10,11), using screw (U) secure door hinge (M,N) to parts (10,11) with Philips head screwdriver as per diagram.

Step 12

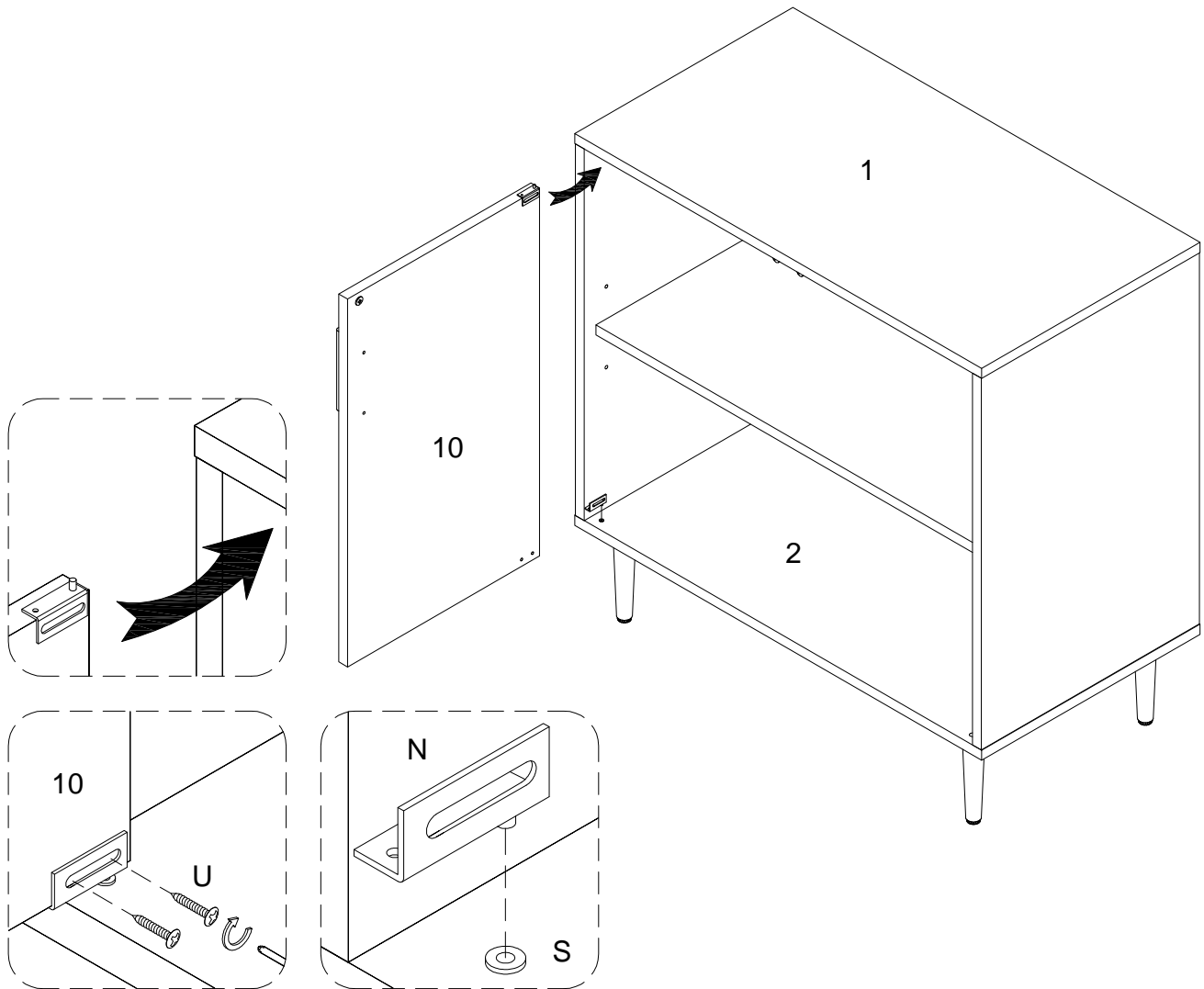

Insert top door hinge (M) into plastic pivot (S) on part (1), then slide the door (10) into bottom hinge (N). Secure door by tightening door hinge (N) using screws (U) with equal pressure.

Step 13

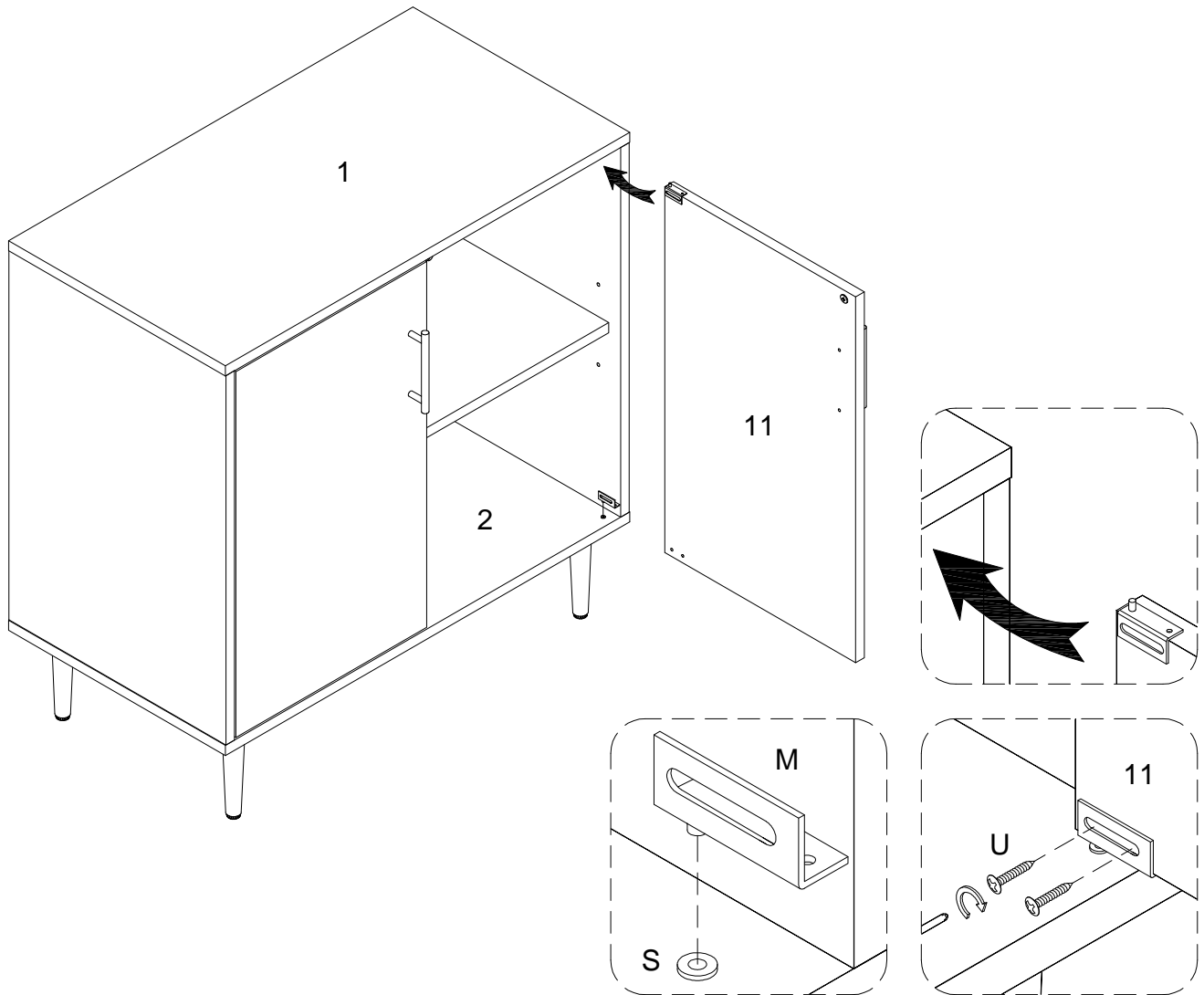

Insert top door hinge (N) into plastic pivot (S) on part (1), then slide the door (11) into bottom hinge (M). Secure door by tightening door hinge (M) using screws (U) with equal pressure.

Step 14

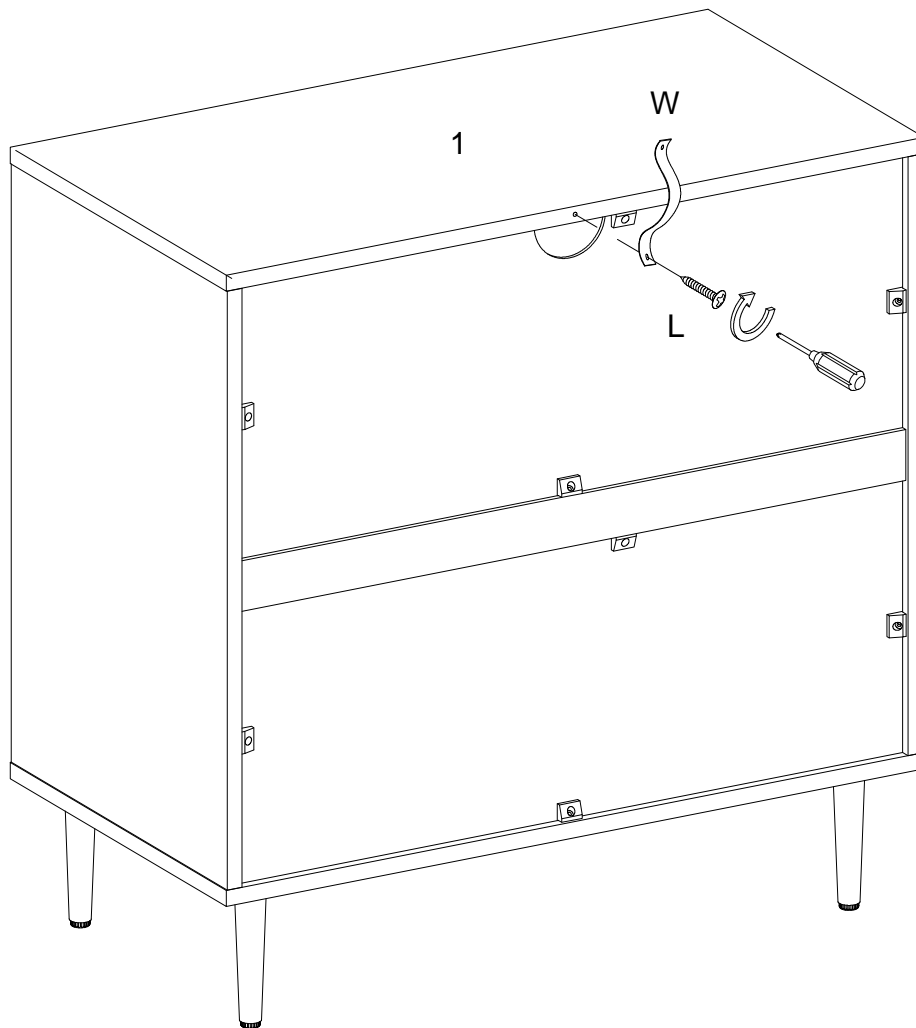

Using screw (L) secure plastic strap (W) into part (1) with Philip head screwdriver .

Step 15

WARNING

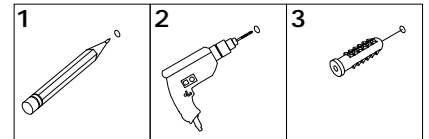

Serious or fatal injuries can occur from furniture tipping over. To prevent the furniture from tipping over we recommend that it is permanently fixed to the wall. Wall anchor and hardware are included with this product. Please make sure hardware is suitable for your walls before installing, as different wall materials may require different types of anchors.

Wall

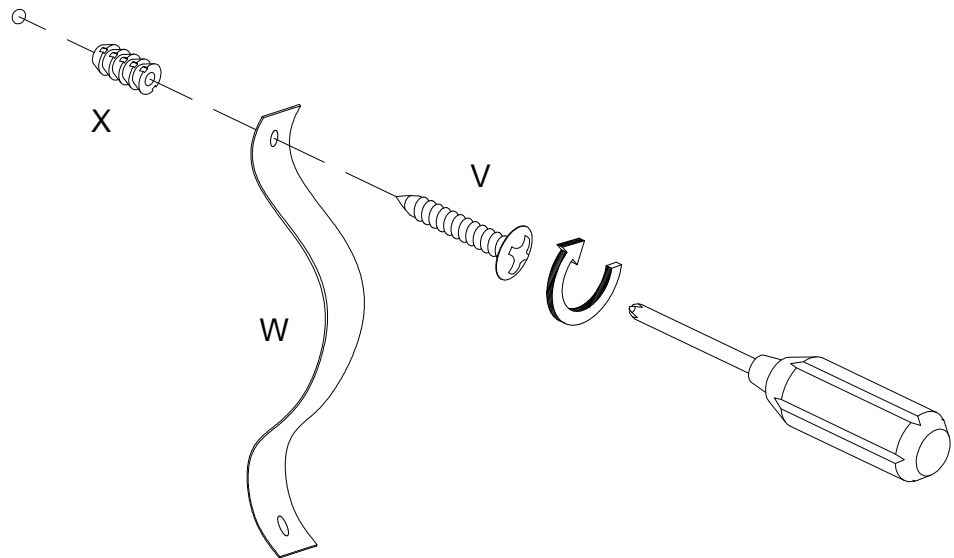

Using screw (V) secure plastic strap (W) into nut (X) to wall with Philip head screwdriver .

Step 16

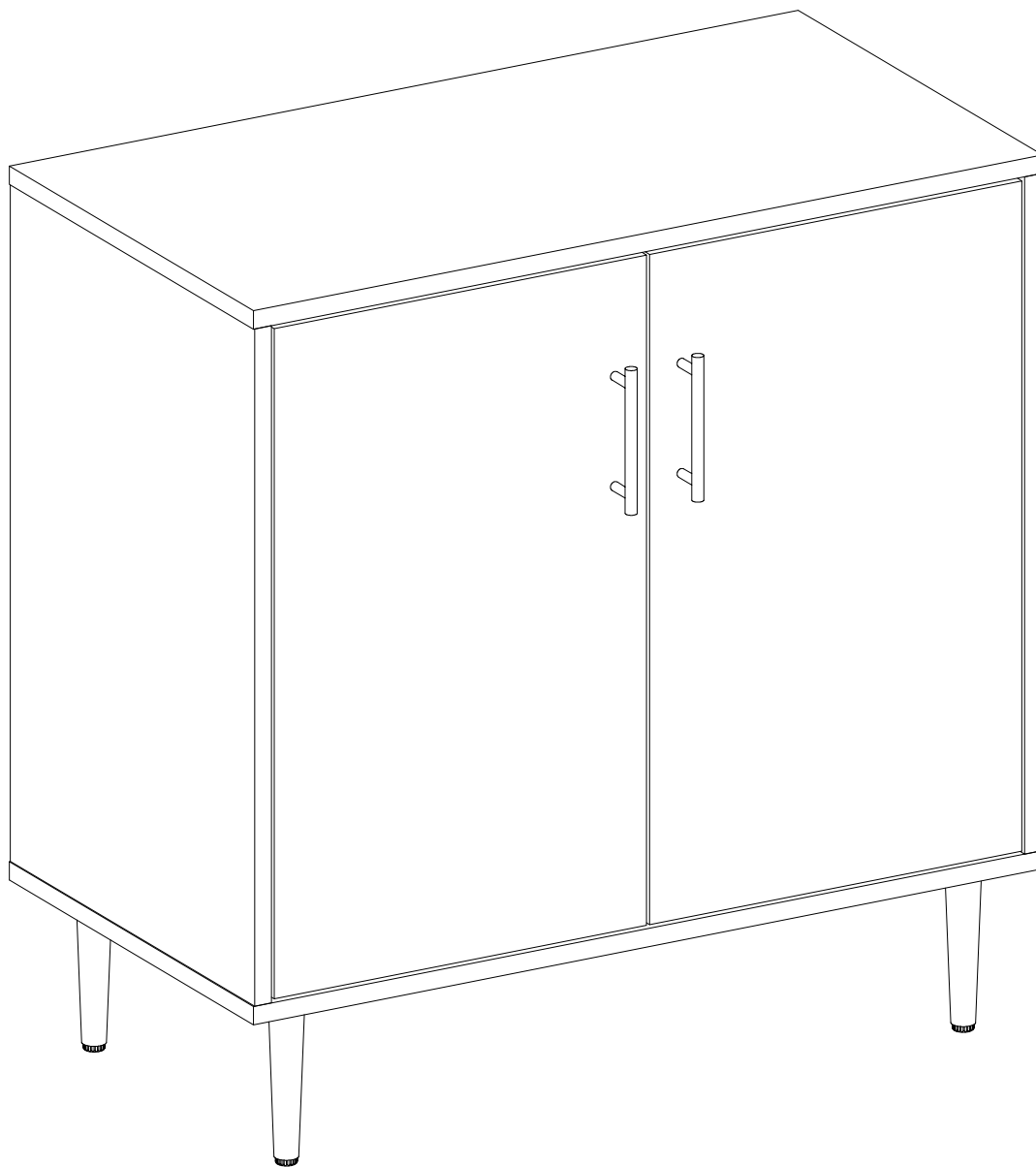

Final Assembly