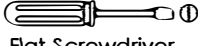
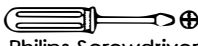
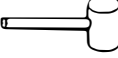

ASSEMBLY INSTRUCTIONS

3 DRAWER CABINET

ASSEMBLY REQUIREMENTS	2–Person Assembly	2.5Hours Assembly Time (Approximate)	Tool Required (Not Provided)	 Flat Screwdriver  Phillips Screwdriver	 Mallet
------------------------------	----------------------	--	---------------------------------	--	---

Thank you for purchasing our product!

Please refer and use this assembly instruction to assemble the product.
 Contact our customer service department in case there are any missing or damage parts or hardware.
 Replacement parts are normally shipped within 2 or 3days.

We appreciate your business!

PRODUCTS PURCHASED THROUGH OUR AUTHORIZED VENDORS ONLY ARE ELIGIBLE FOR REPLACEMENT PARTS

ASSEMBLY PREPARATION:

- 1 .Remove all packaging materials, staples and packing straps from the carton.
- 2 .Refer to Part List and Hardware List and ensure parts and hardware are correct before assembly.
 Contact customer service for missing parts.
- 3 .Place all wooden parts on clean ,flat and soft surface (e.g. carpet or rug)to prevent scratch and damage to parts.

SAFETY PRECAUTION:

- 1 .Keep ALL HARDWARE PART OUT OF REACH OF CHILDREN.
- 2 .DISPOSE PLASTIC PACKAGING MATERIAL IMMEDIATELY TO AVOID ANY RISK OF SUFFOCATION TO CHILDREN AND ANIMALS

TIPS FOR ASSEMBLY:

- 1 .Allow ample room for assembly and assemble the product near where the product will be placed.
- 2.Assemble the product on a surface that does not scratch or damage the exterior gloss and finish of the furniture.
- 3 .Identify all the parts ,hardware and quantities required for each step.
- 4 .During assembly ,do not over-tighten any fittings as this may cause damage.
- 5 .DO NOT USE POWER TOOLS TO ASSEMBLE THIS PRODUCT.
- 6 .Always place the product on a flat ,level surface.
- 7 .Do not sit or stand on the partially assembled product; only use the product for which it is intended.

CARE AND MAINTENANCE:

Use a slightly damp cloth to clean the product .Do not use bleach or abrasive cleaning material.
 Check all the fittings periodically and re-tighten as necessary .Do not use the product if any of the parts is damaged or broken.
 Never allow any kind of liquids to remain on your furniture .Absorption can cause wood to warp or delaminate.
 Do not place hot items (e.g hot drinks) directly onto the wood surface.
 Do not drag and pull the furniture.







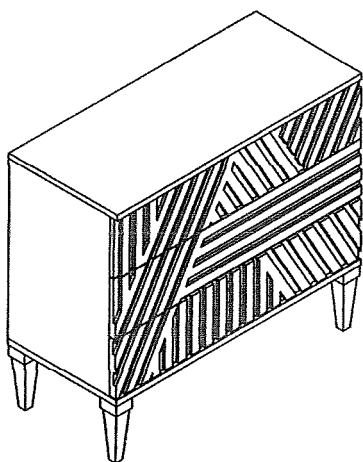

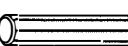

This product is for indoor and household use only – not for commercial or industrial use.

ASSEMBLY INSTRUCTIONS





3 DRAWER CABINET



HARDWARE LIST

NO	DESCRIPTION	QTY	EXTRA
A	 CHIPBOARD SCREW M4 x 16MM	36	1
B	 CHIPBOARD SCREW M4 x 38MM	4	1
C	 WOOD DOWEL M8 x 35MM	20	1
D	 WOOD DOWEL M6 x 30MM	36	1
E	 CAM-LOCK 15x 12	20	1
F	 CAM-BOLT 5x 25	20	1
G	 CAM-LOCK COVER 17x 5	20	1
H1	 DRAWER SLIDE 350MM	3	SET
H2			
I	 PANHEAD CHIPBOARD SCREW M4 x 16MM (BLACK)	20	1
J	 FLAT WASHER M8	4	1
K	 SPRING WASHER M8	4	1

HARDWARE LIST

NO	DESCRIPTION	QTY	EXTRA
L	 HEX NUT M6	4	1
M	 WRENCH	1	
W	 CHIPBOARD SCREW M4 x 25MM	4	1
X	 FLAT WASHER M4	2	
Y	 WALL ANCHOR	2	
Z	 SAFETY STRAP 150mm	2	

DRAWER SLIDE DISASSEMBLE STEPS:

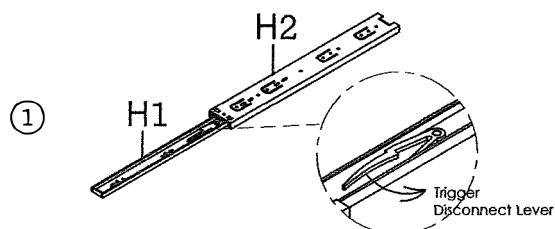

- A) Distinguish between Slide Track (H2) and Slide Runner (H1) of Drawer Slide.
- B) Slide out H1 from H2 until Trigger Disconnect Lever is visible.
- C) Depress the Trigger Disconnect Lever in the groove of H1 and at the same time slide out H2 completely from H1.

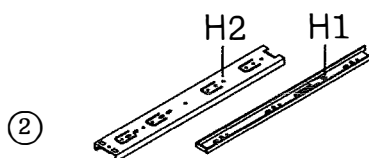

**EXTRA HARDWARE FOR SPARE USE

PARTS LIST

NO	PART NAME	QTY
1	TOP PANEL	1
2	LEFT PANEL	1
3	RIGHT PANEL	1
4	BOTTOM FRAME	1
5	CENTER BAR	2
6	BACK PANEL	1
7	LEG	4
101	TOP DRAWER FRONT PANEL	1
102	DRAWER LEFT PANEL	3
103	DRAWER BACK PANEL	3

NO	PART NAME	QTY
104	DRAWER BASE PANEL	3
105	DRAWER RIGHT PANEL	3
106	CENTER DRAWER FRONT PANEL	1
107	BOTTOM DRAWER FRONT PANEL	1

PARTS ASSEMBLY OVERVIEW

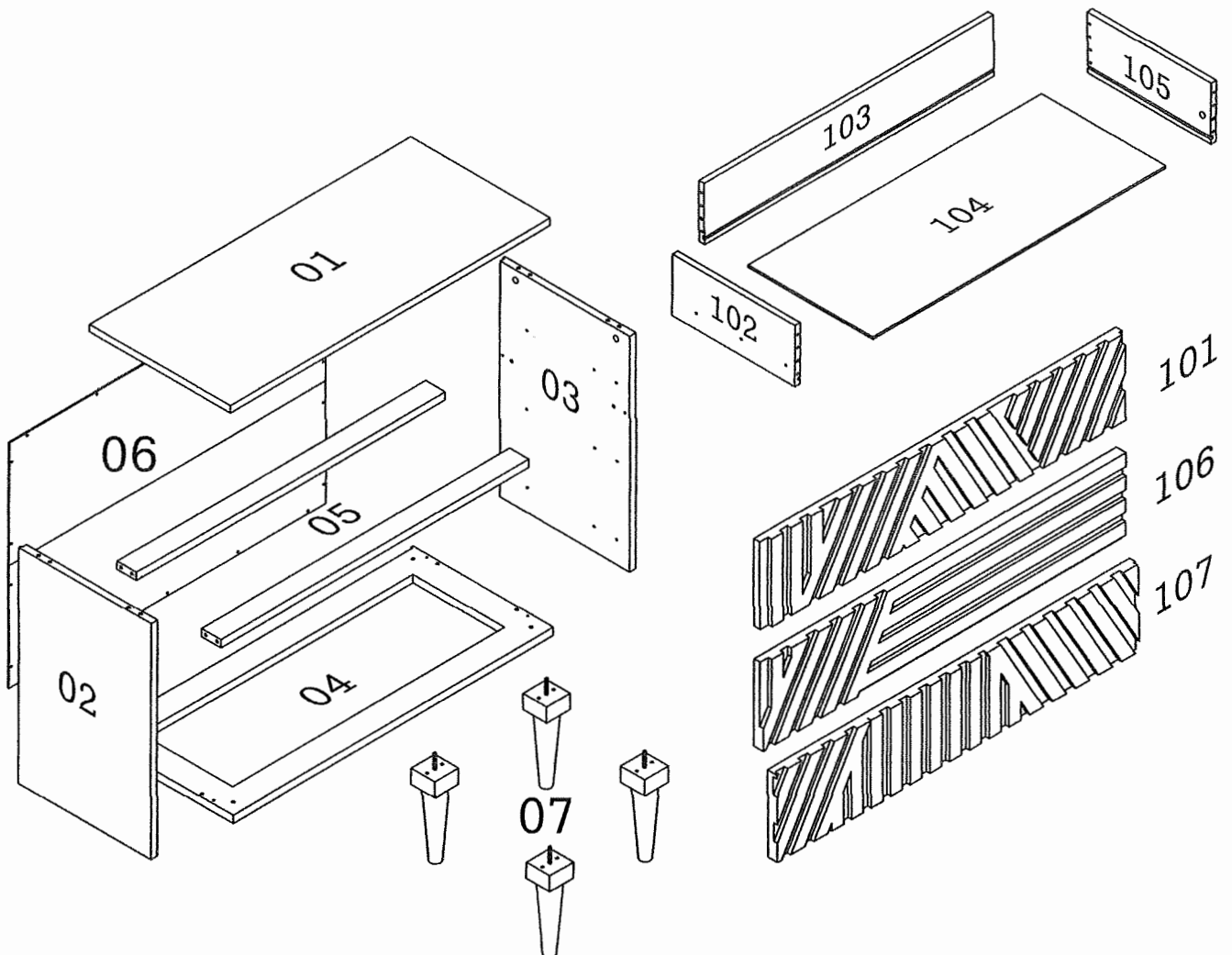

INSTRUCTION FOR CAM-BOLT & CAM-LOCK

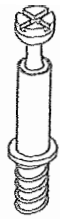

CAM-BOLT



CAM-LOCK

Tools Required



INSERTING AND TIGHTENING CAM-BOLT

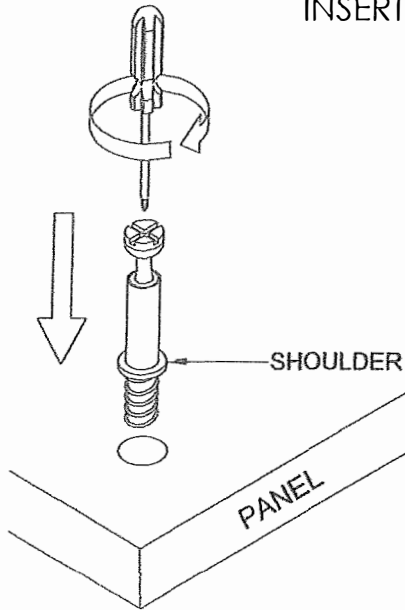

Place Cam-bolt on pre-drilled hole and screw in vertically

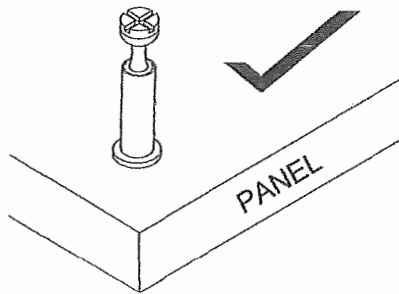

Shoulder is flushed (on the same level) with the panel.

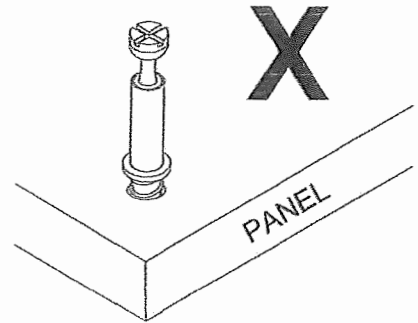

Shoulder is above the panel.

Place Cam-bolt on the designated pre-drilled holes on the panel. Use a Phillips Screwdriver to screw-in Cam-bolt vertically until shoulder is flushed (on the same level) with panel.

INSERTING CAM-LOCK

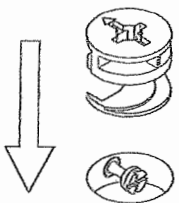

Insert Cam-lock with arrow align to Cam-bolt head

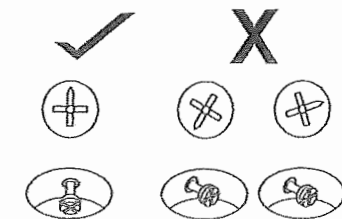

CORRECT

WRONG

TIGHTENING CAM-LOCK

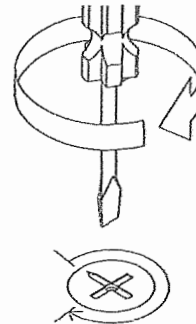

Use a Flat-head Screwdriver to turn Cam-lock clockwise so it locks onto the head of the Cam-bolt. Turn until it is snug (about 3/4ths of a turn) -- over-tightening could damage Cam-lock or/and Cam-bolt.

CAM-LOCK

Align the arrow on the Cam-lock to the Cam-bolt head and insert the Cam-lock. Ensure Cam-lock is fully inserted.

STEP 1

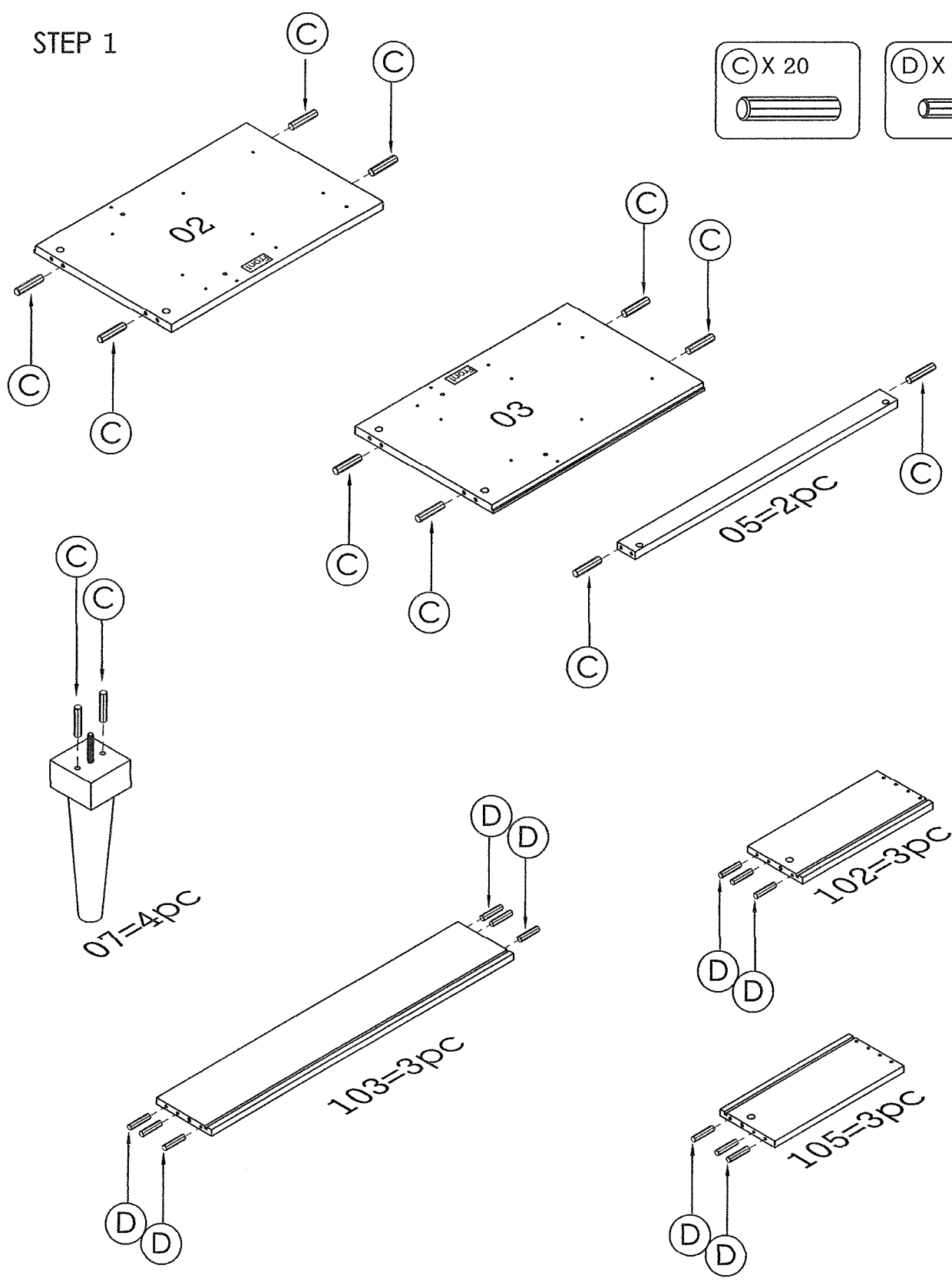
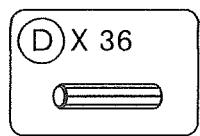
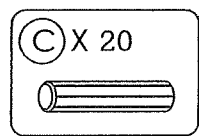

- A. Lay Left & Right Panel (2 & 3), Center Bar (5), Leg (7), Drawer Back Panel (103), Drawer Left & Right Panel (102 & 105) as shown and identify the designated holes for Wood Dowel (C or D) on each part.
- B. Insert Wood Dowel (C or D) into the designated holes of the respective parts, use a mallet or hammer to lightly tap in Wood Dowel (C or D) if necessary.

STEP 2

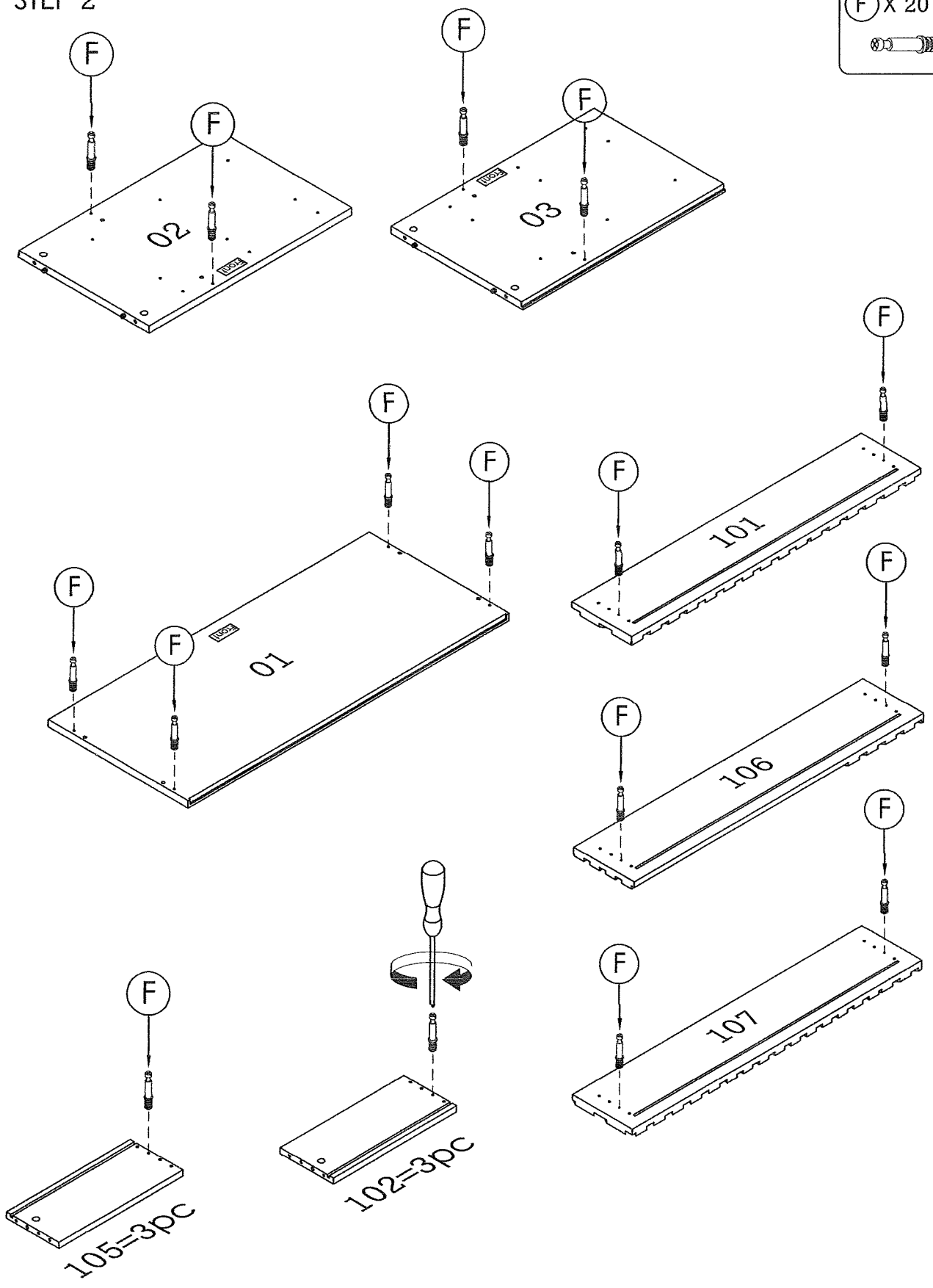
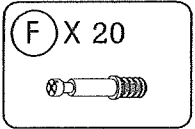

A. Screw in Cam-bolt (F) into the Top Panel (1), Left & Right Panel (2 & 3), Drawer Front (101, 106, 107) Drawer Left & Right Panel (102 & 105) as shown. Refer to page 4 for instructions on inserting and tightening Cam-bolt (F).

STEP 3

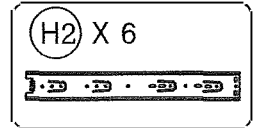
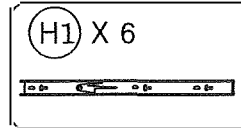
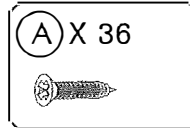

STEP 3A

Identify the pilot holes on Left & Right Drawer Slide (102 & 105) and install Slide Runner (H1) using Chipboard Screw (A) – ensure that the screws are screwed in vertically. Do not tighten the screw completely until all three screws are in place.

Note: The sequence of fastening Screw (A) is from the front to the back.

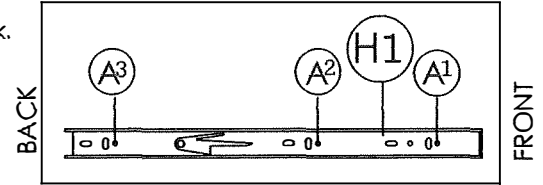
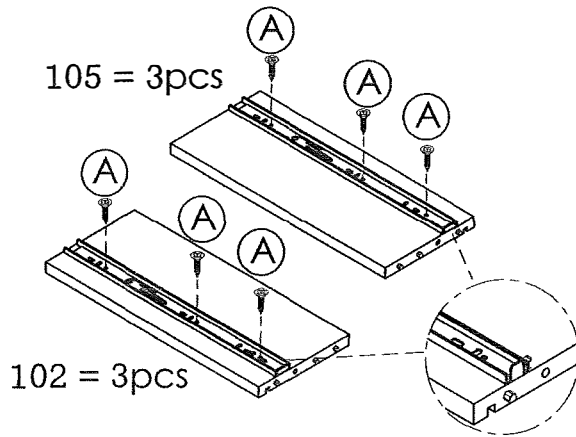

STEP 3B

Identify the pilot holes on Left & Right Panel (2 & 3) and align the designated screw holes on Slide Track (H2) to pilot holes. Use Screw (A) to fasten (H2) ensure that the screws are screwed in vertically. Do not tighten the screw completely until all three screws are in place.

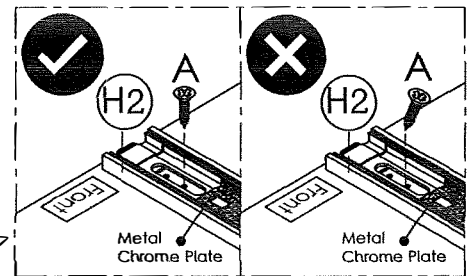
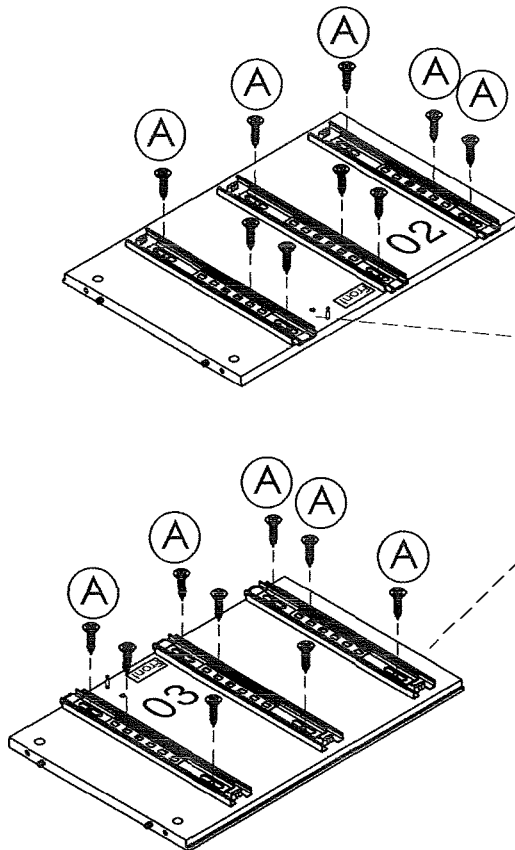

Step 1: Screw in A¹ and A³ on a pilot hole.

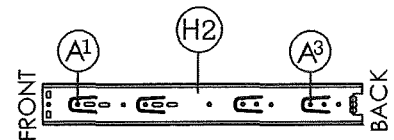

Step 2: Screw in A² on pilot hole.

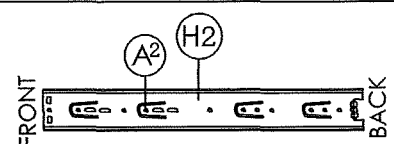

STEP 4

X 3

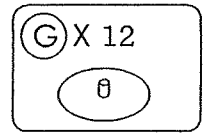
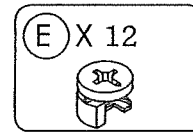
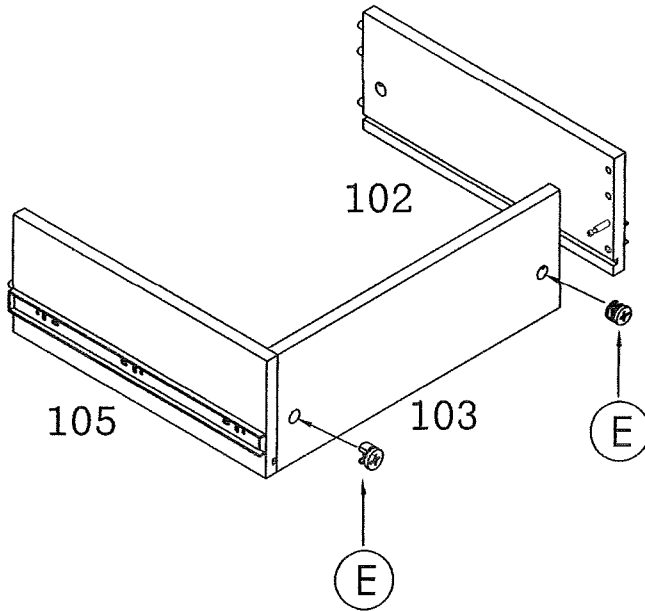

STEP 4A

- Attach Drawer Left and Drawer Right Panel (102 & 105) to Drawer Back Panel (103) via Wood Dowel and Cam-Bolt on each part respectively.
- Insert Cam-lock (E) to designated hole on Drawer Back Panel (103) then turn clockwise to lock onto Cam-bolt. Refer to page 4 for instructions on inserting and tightening Cam-lock.
- Insert Cam-Lock Cover (G) to conceal Cam-Lock (E).

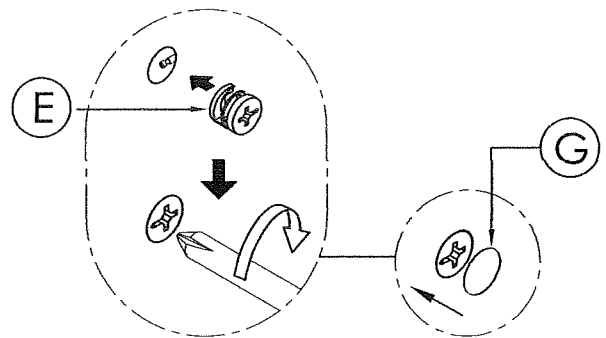

STEP 4B

- Fit Drawer Base Panel (104) via groove on Drawer Side and Back Panel.
- Attach Drawer Front Panel (101, 106 & 107) to Drawer Left & Right Panel (102 & 105) via Cam-Bolt and Wood Dowel on the respective parts. Check that Drawer Base Panel (104) fits into the groove on the inside face of the respective Drawer Front Panel (101, 106 & 107).
- Insert Cam-lock (E) into designated holes on Drawer Left & Right Panel (102 & 105) and turn clockwise to lock onto Cam-bolt.
- Insert Cam-lock Cover (G) to conceal Cam-lock.

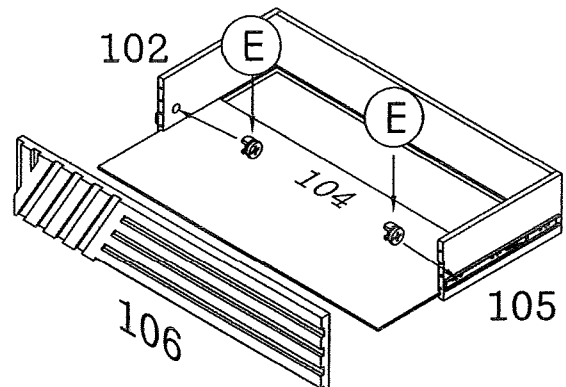
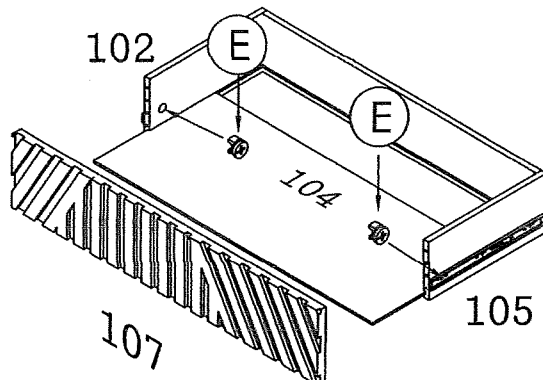
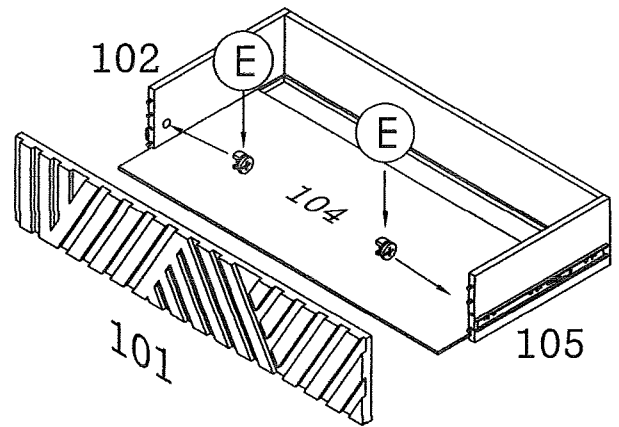

STEP 5

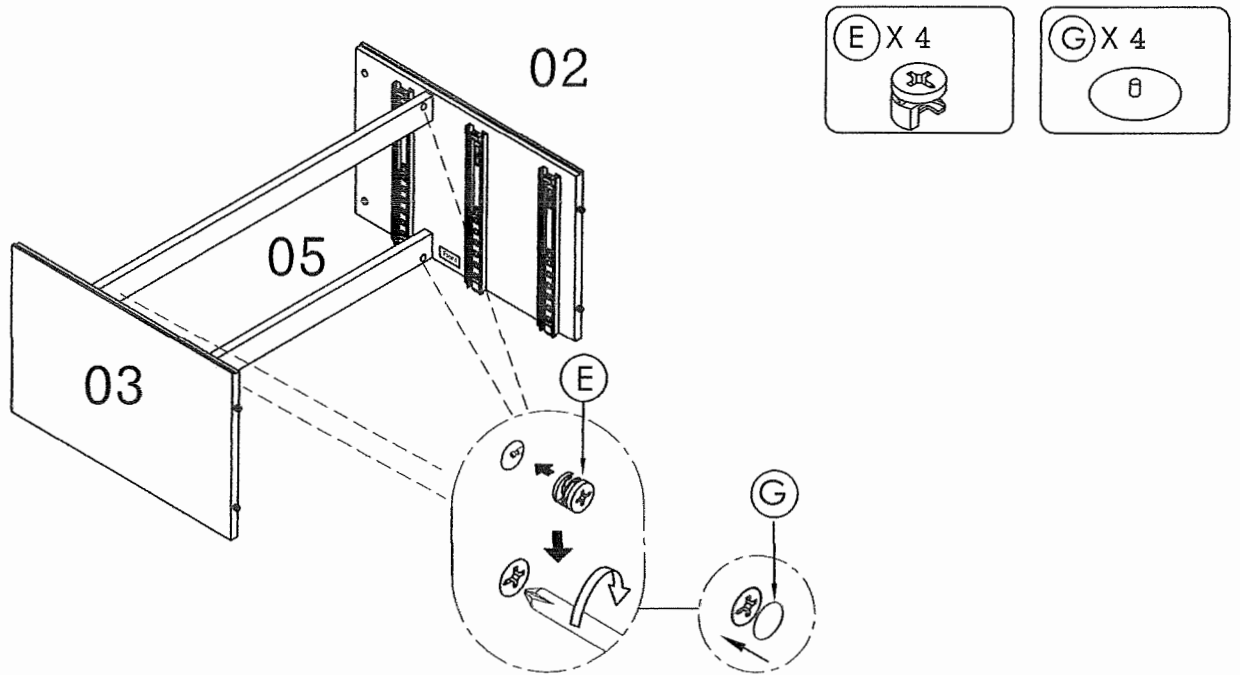

- A. Position the parts as shown and attach Center Bar (5) to Side Panel (2 & 3) via Cam-Bolt and Wood Dowel on the respective parts.
- B. Insert Cam-lock (E) into designated hole on Center Bar (5), then turn clockwise to lock onto Cam-bolt. Refer to page 4 for instructions on inserting and tightening Cam-lock (E).
- C. Insert Cam-lock Cover (G) to cover Cam-lock (E).

STEP 6

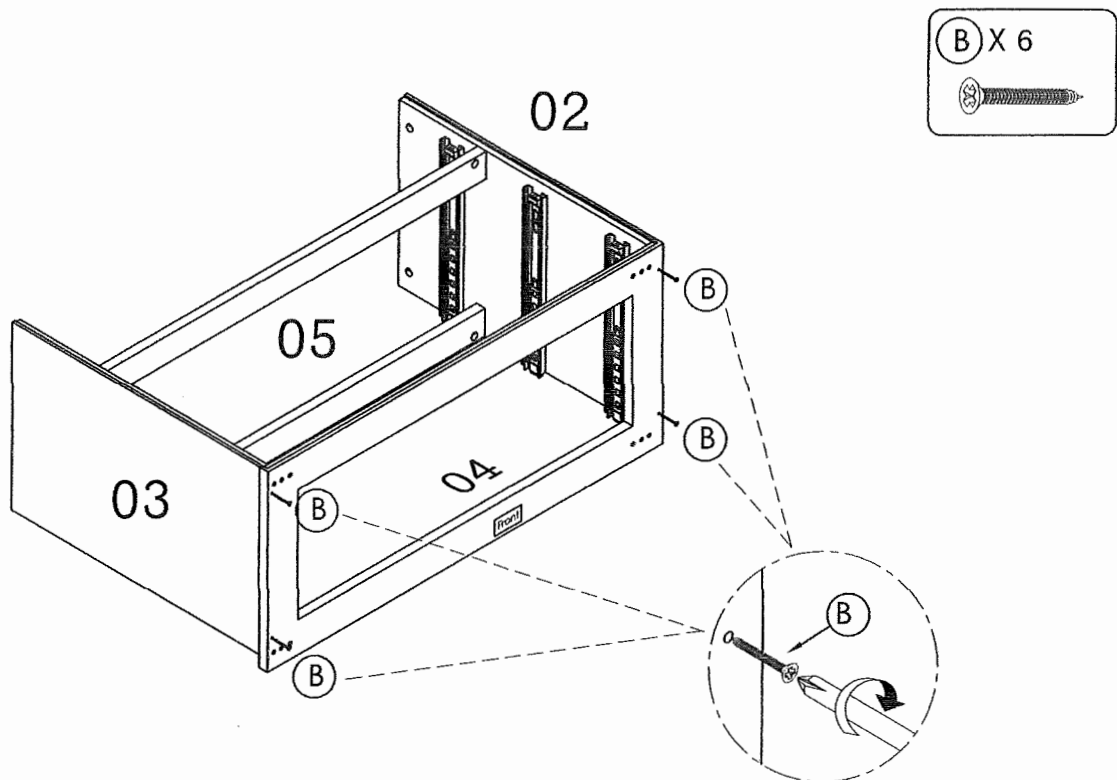

- A. Use Chipboard Screw (B) to fasten Bottom Frame (4) to Left & Right Panel (2 & 3). Do not tighten Screw (B) completely until all the screws are in place.

STEP 7

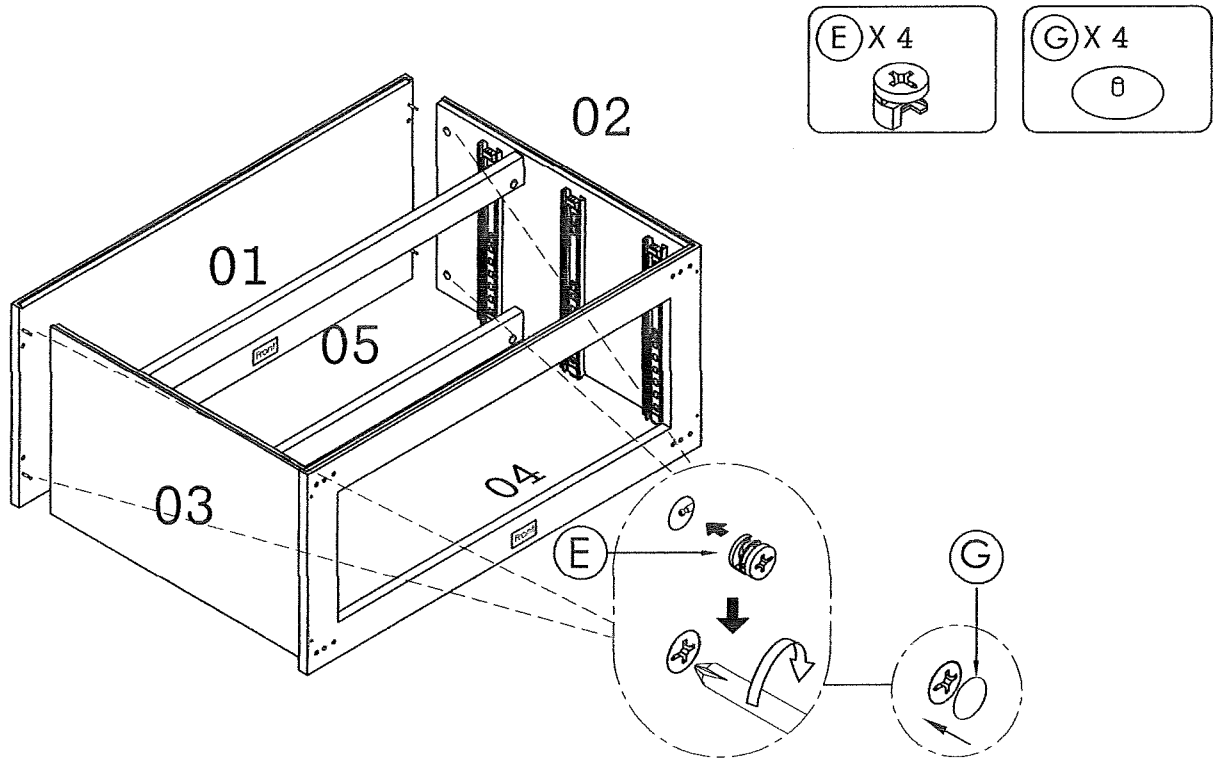

- A. Attach Top Panel (1) to Left & Right Panel (2 & 3) via Cam-bolt (F) and Wood Dowel (C) on respective parts.
- B. Insert Cam-lock (E) into designated hole on Left & Right Side Panel (2 & 3), then turn clockwise to lock onto Cam-bolt (F).
- C. Insert Cam-lock Cover (G) to conceal Cam-lock (E).

STEP 8

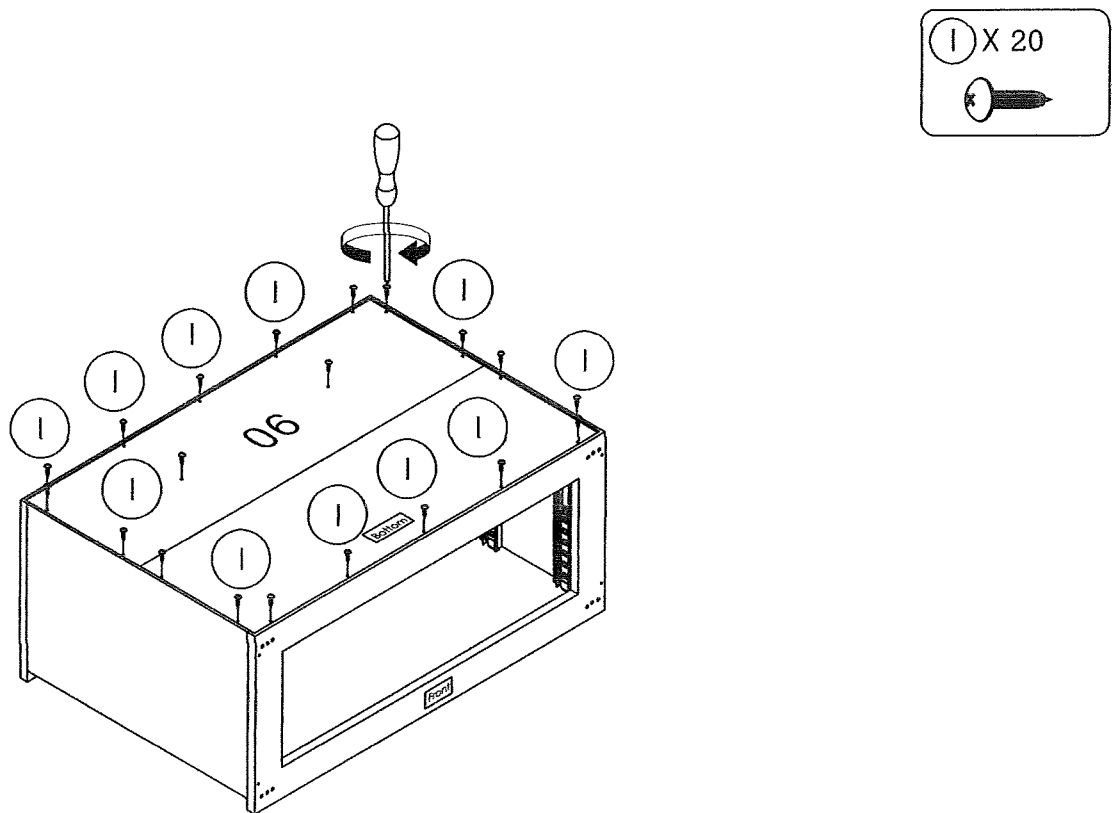

- A. Attach Back Panel (6) to assembly unit as shown and fasten with Panhead Chipboard Screw (I).

STEP 9

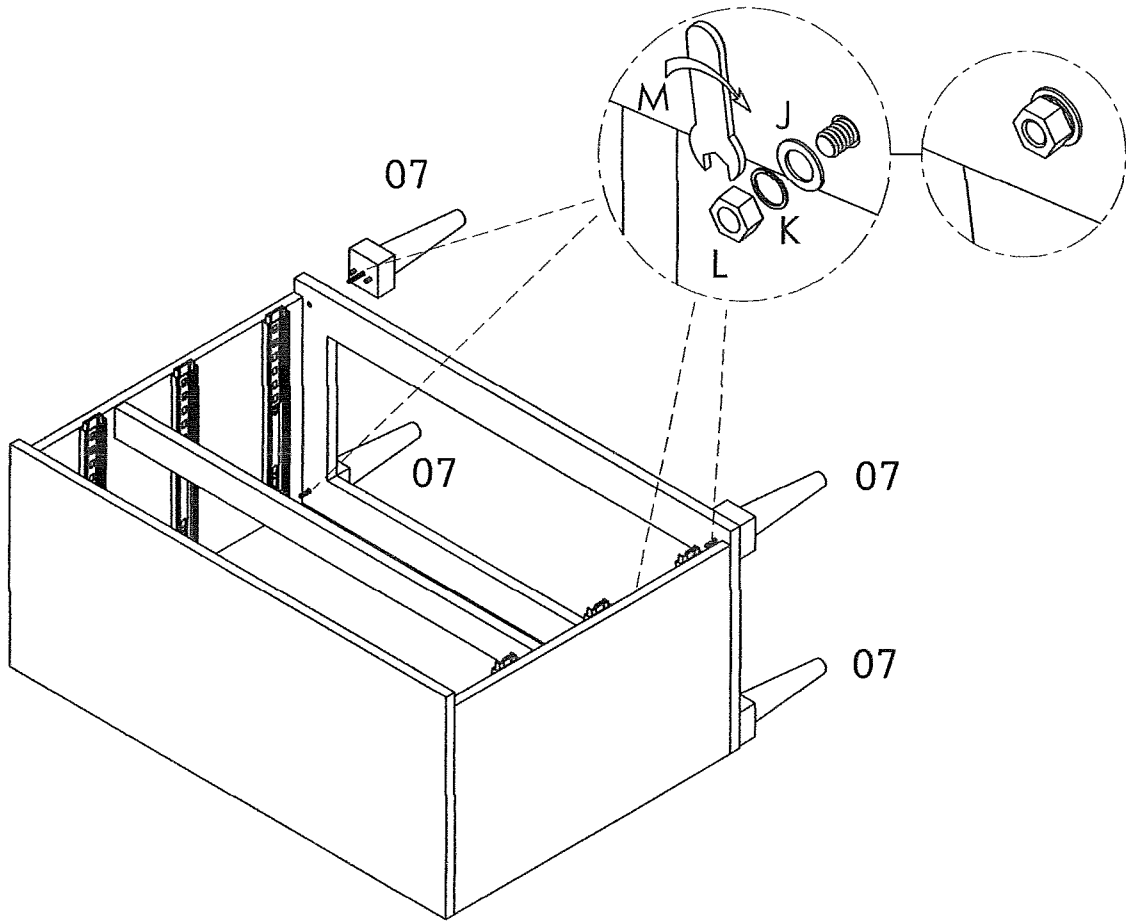
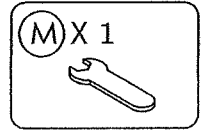
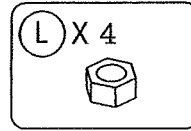
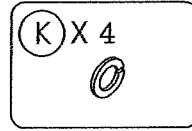
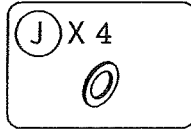

A. Attach Leg (7) to Bottom Frame (4) and fasten with Flat Washer (J), Spring Washer (K) and Hex Nut (L).
Use Wrench (M) to tighten Hex Nut (L).

STEP 10

STEP 10A

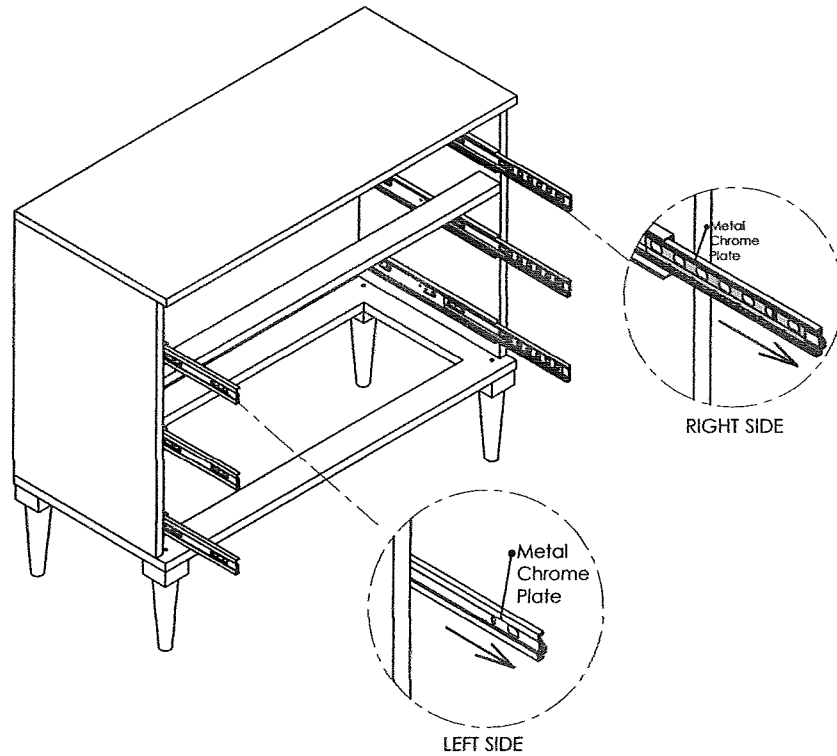

- A. On the Left and Right Panel, Slide out the metal chrome Plate (ball bearing slider) on Slide Track.

STEP 10B

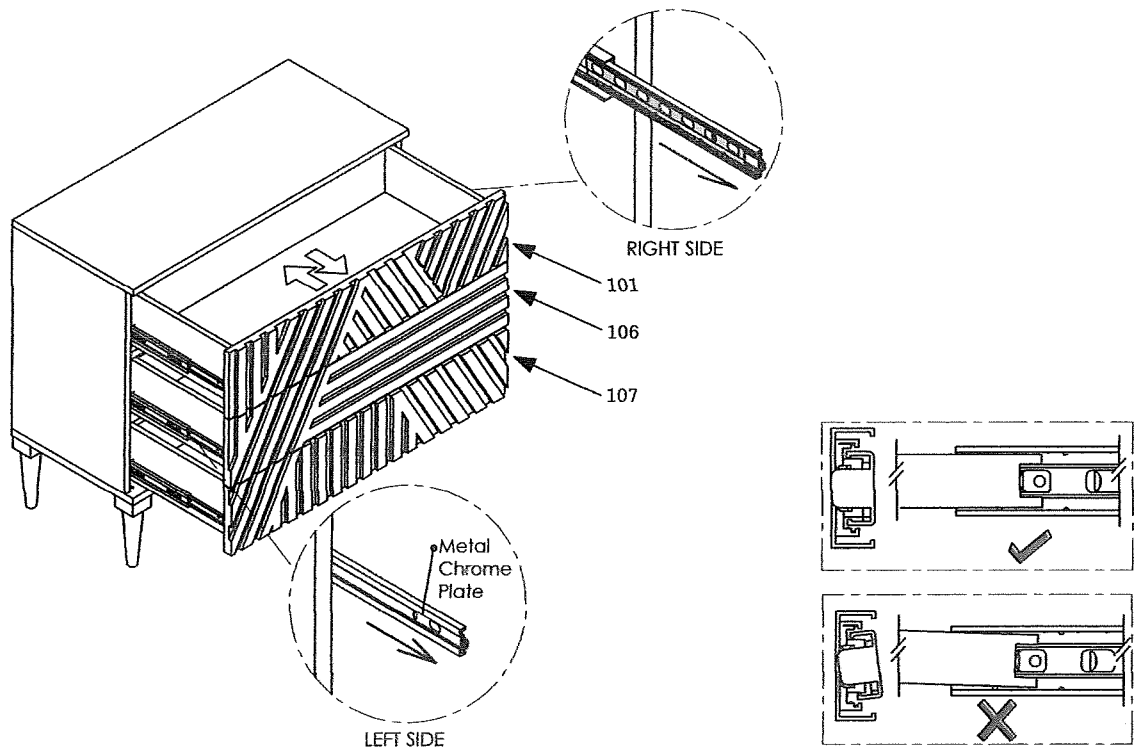

- A. Align the back open-end of the Slide Runner on each side of the drawer to fit squarely into the groove on the open front-end metal chrome plate of the Slide Track on Left and Right Panel. Be sure the drawer is not tilted or angled, and push in drawer squarely.
- B. When the drawer is pushed in about half way, the Trigger Disconnect Lever on (H2) will be engaged onto (H1) which will create a slight resistance - this is normal. Pull out the drawer a little bit and gently push in the drawer again to engage the trigger Disconnect Lever to the Slide Mechanism on (H1). The Drawer Should now slide smoothly.
- C. If the drawer cannot be pushed in or stuck, do not force it in. Remove the drawer and repeat the steps above.

STEP 11

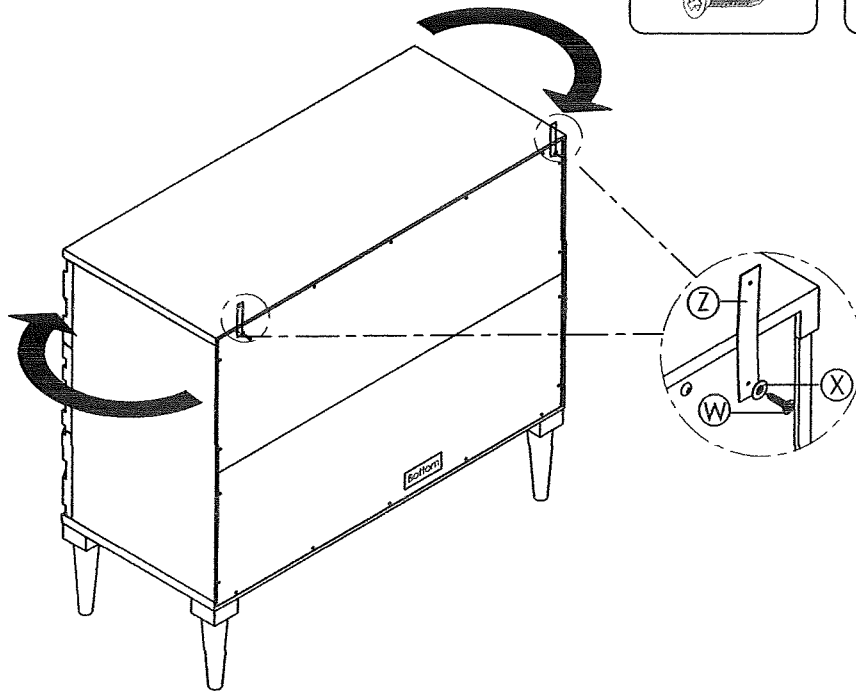
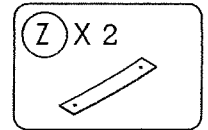
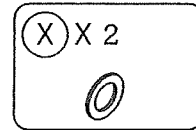
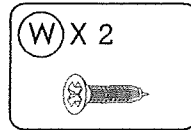

Use Screw (W) fitted with Flat Washer (X) to fasten one end of Safety Strap (Z) to the Back Panel.

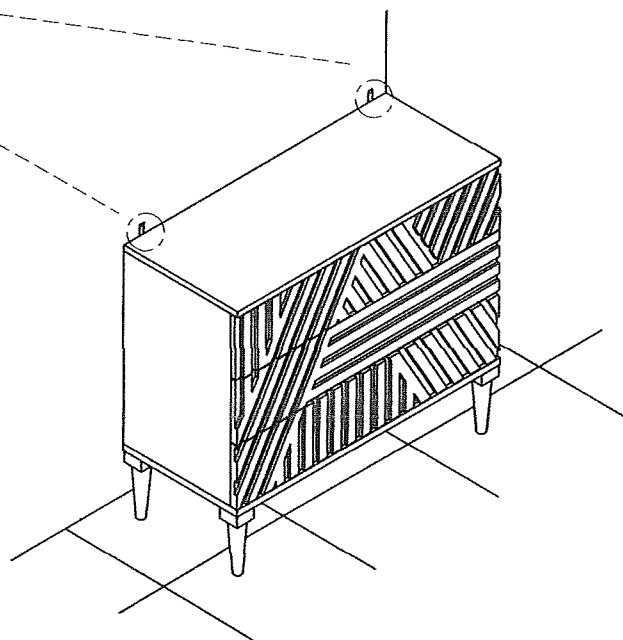
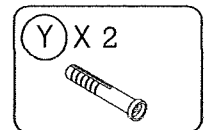
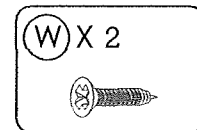
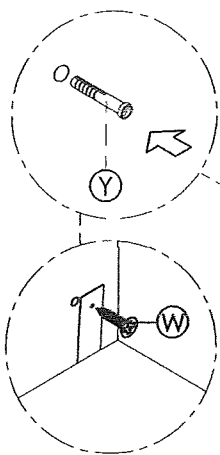

- a) Select the location to place the unit. Mark the 2 spots to tether the Safety Strap to the wall.
- b) On each marked spot, drill a hole in the dry wall to fit Anchor (Y) snugly and insert (Y). Ensure that the anchor fits securely in the wall.
- c) Affix the Strap to the anchor by using Screw (W).

The assembly of the cabinet is complete.