

ASSEMBLY INSTRUCTIONS

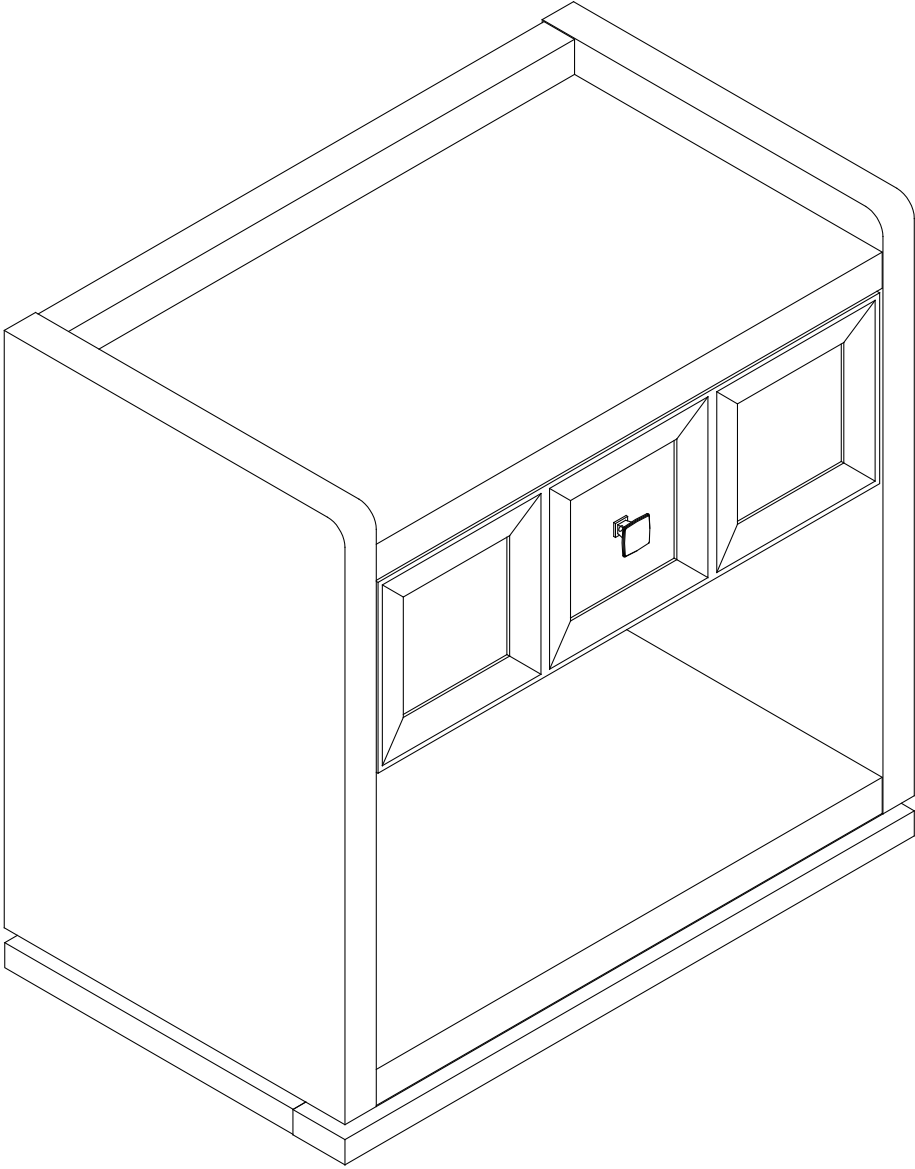

Made In China

Assembly Instructions

Before beginning the assembly process, please read and save these instructions for reference. Following these guidelines will ensure a smooth and successful assembly of your product.

1. Part Identification:

Carefully separate and identify all the parts included in your package. Confirm that you have all the components listed in the instruction manual. This step will help you avoid any missing or misplaced parts during assembly.

2. Work Surface:

To prevent any scratches or damage to the product, assemble it on a soft mat or a similar protective surface. This will provide a cushioned area for the components and protect the surfaces from unwanted marks.

3. Step-by-Step Assembly:

Follow the assembly instructions provided, proceeding one step at a time. Take care to understand each step properly before proceeding to the next one. This sequential approach ensures that the assembly is done correctly and minimizes the chance of errors.

4. Proper Screw Seating:

When attaching screws and nuts, it is essential not to fully tighten them until all screws are correctly seated. By partially tightening each screw and nut initially, you can ensure that they are aligned properly and fit securely before final tightening.

5. Avoid Over-Tightening:







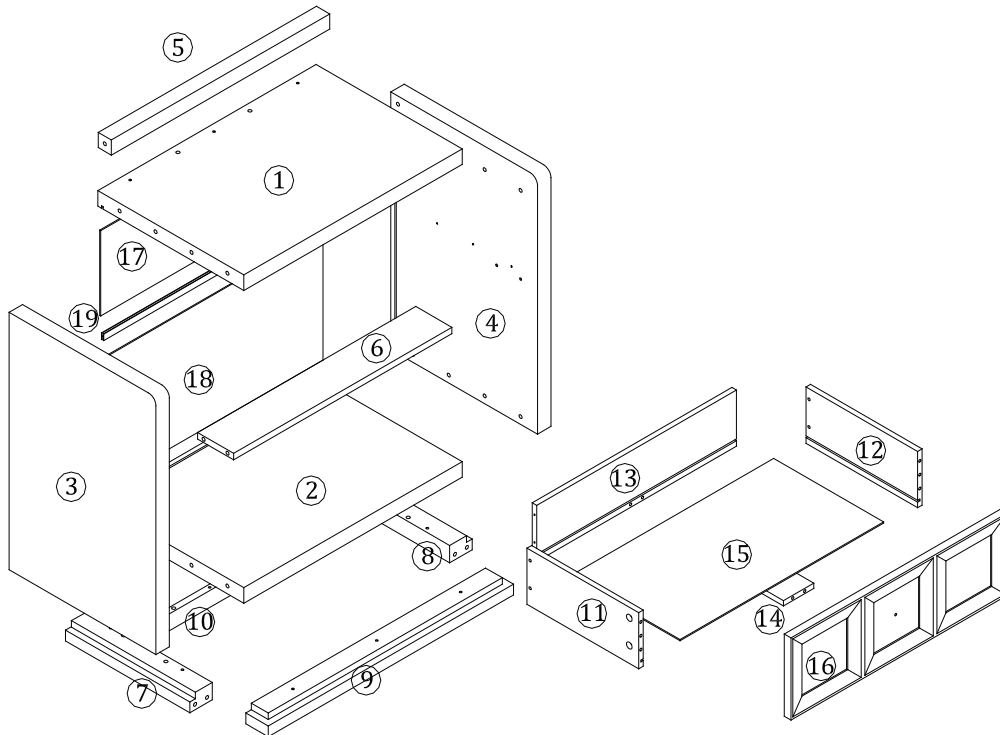









While each screw and nut should be tightened correctly, it is crucial not to over-tighten them. Over-tightening can cause damage to the product or compromise its structural integrity. Use the appropriate amount of force to secure the components without excessive tightening.

If you encounter any questions or problems during the assembly process, please do not hesitate to contact us. We strive to provide excellent customer support and will respond to your inquiries within 24 hours. Our team will offer you a suitable solution to address any concerns you may have.

Parts List

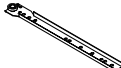

Hardware List

A *15  Ø15x9.5mm	B *15  Ø6x24mm	C *22  Ø8x30mm	D *5  Ø4x30mm	E *1  M4x15mm	F *1 	G *12  Ø3.5x12mm
H *4  Ø6x30mm	I *10 	J *10  Ø3x16mm	K *4 	L *13  Ø4x50mm		
CL *1  300mm	CR *1  300mm	DL *1  300mm	DR *1  300mm	M		

Code	Description	Quantity
A	Ø15x9.5mm Cam lock	15+2
B	Ø6x24mm Cam bolt	15+2
C	Ø8x30mm Wood dowel	22+2
D	M4x30mm Screw	5+2
E	M4x15mm Bolt	1
F	Handle	1
G	M3.5x12mm Screw	12+2
H	Ø6x30mm Wood dowel	4+2

Code	Description	Quantity
I	Backboard clip	10+2
J	Ø3.5x16mm Screw	10+2
K	Adjustable foot pad	4+1
L	Ø4x50mm Screw	13+2
M	Drawer runner set	1

Step 1

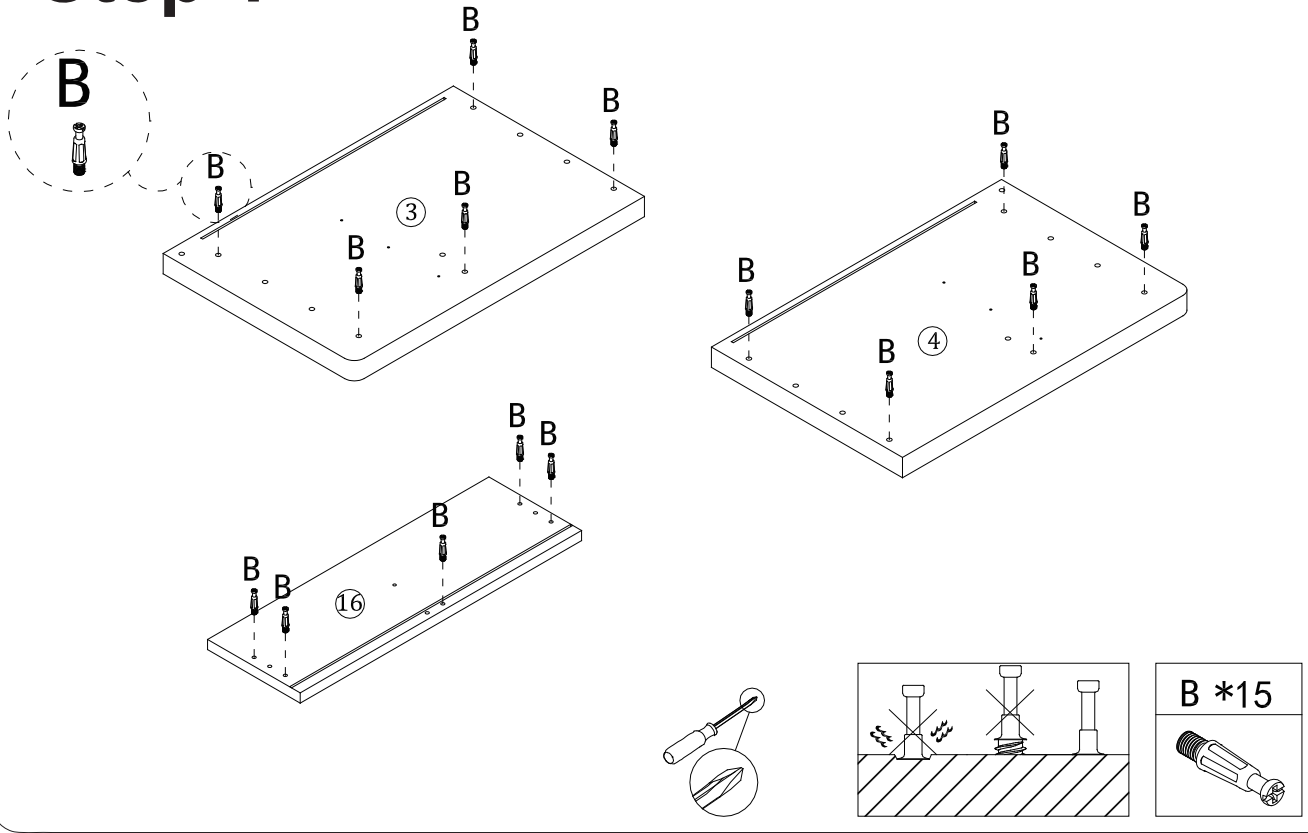

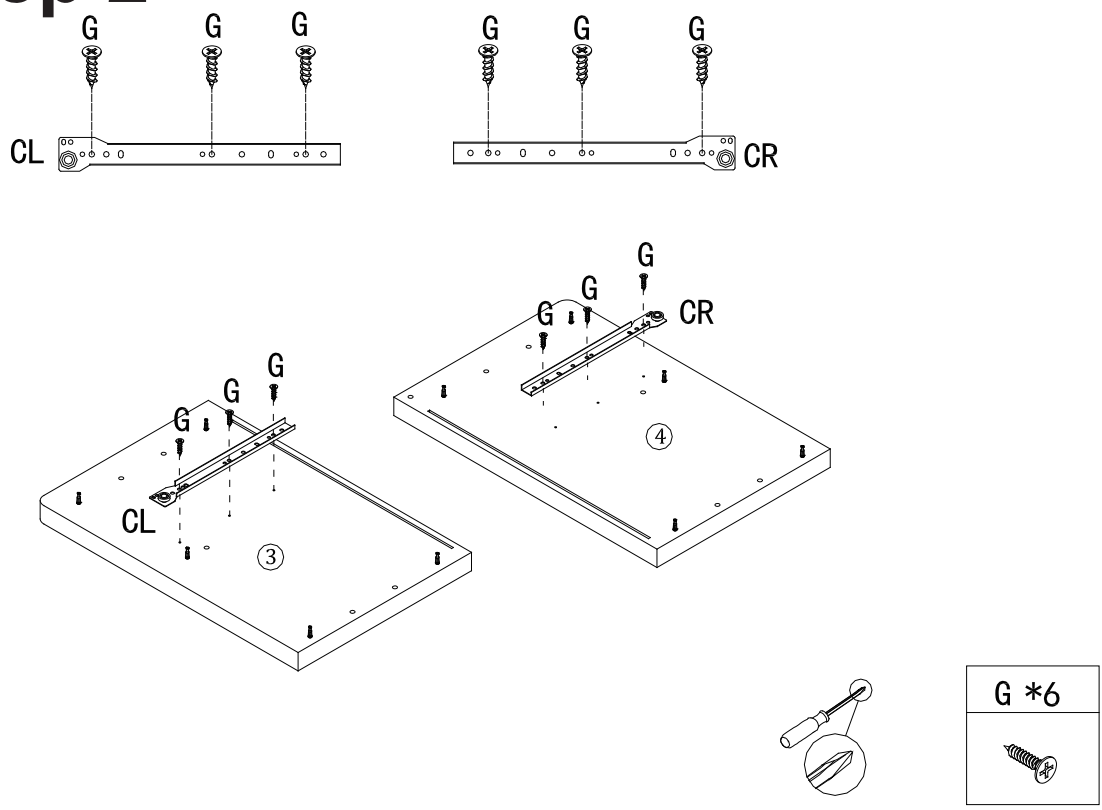

Step 2



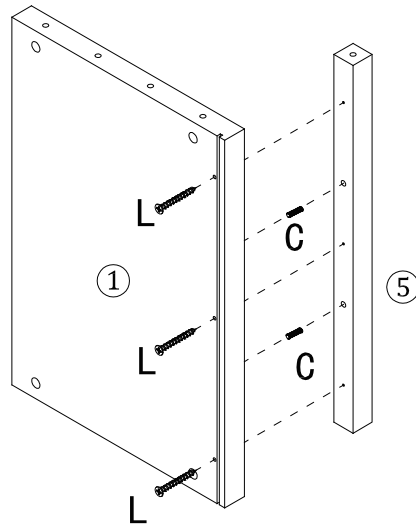

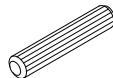
Step 3

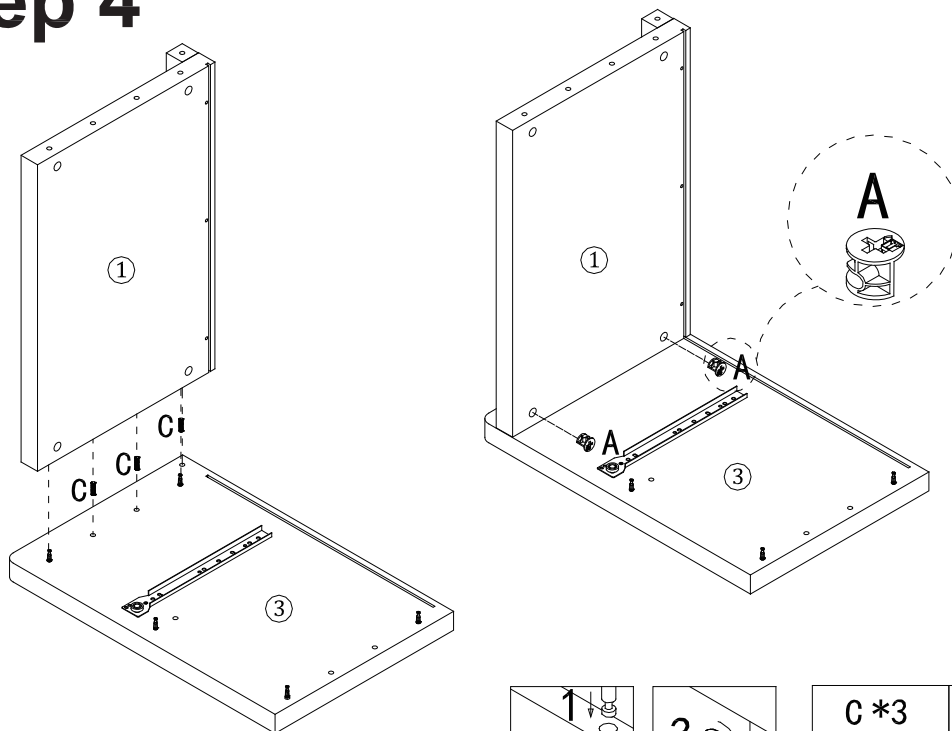

C *2	L *3
	

Step 4

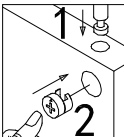
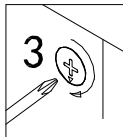

		C *3	A *2
			

Step 5

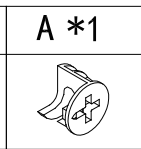
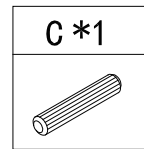
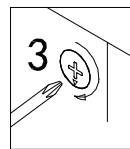
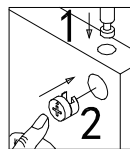
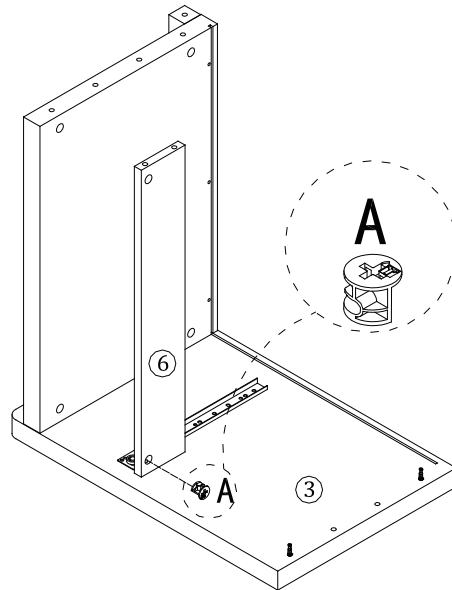
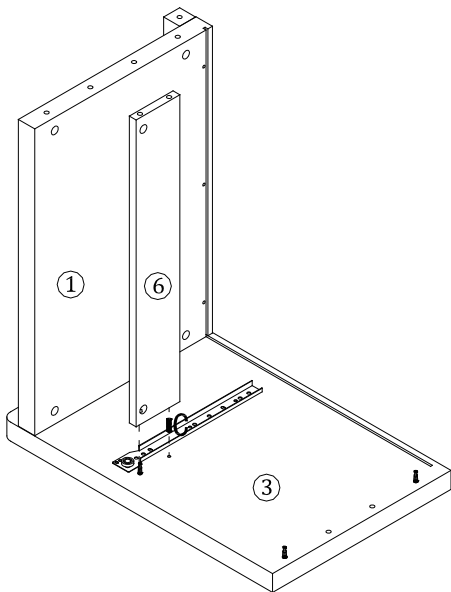

Step 6

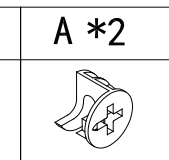
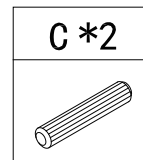
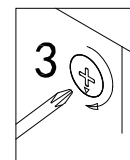
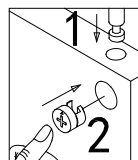
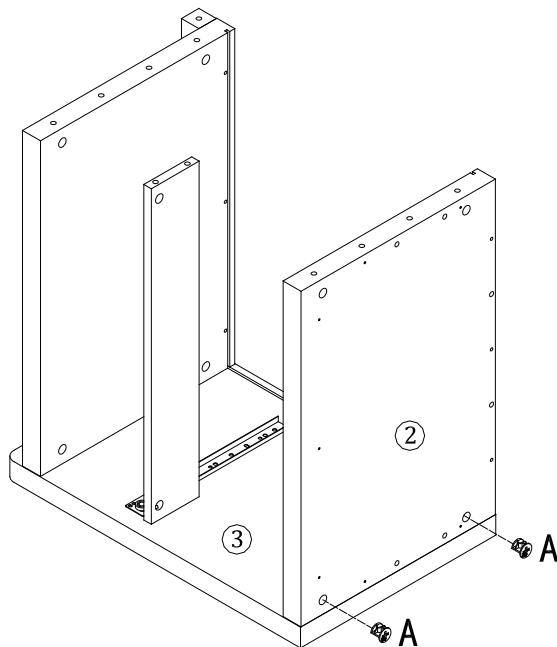
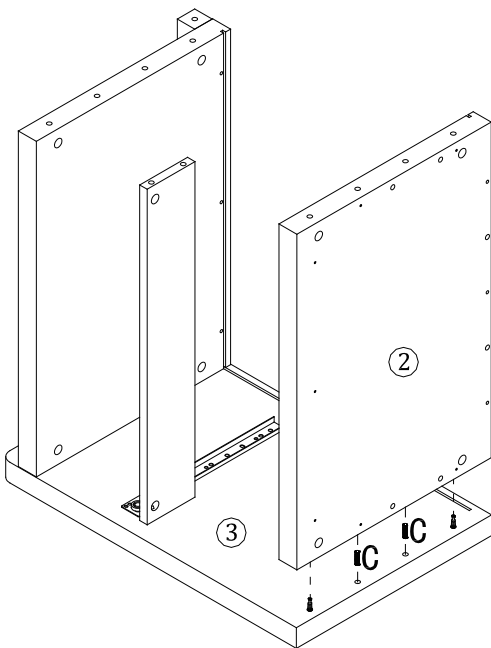

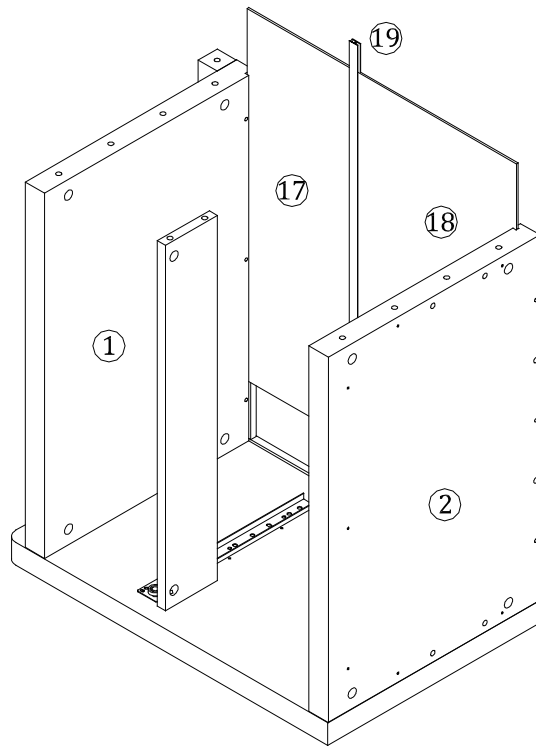

Step 7

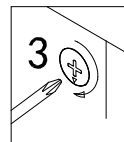
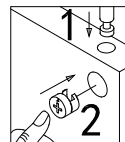
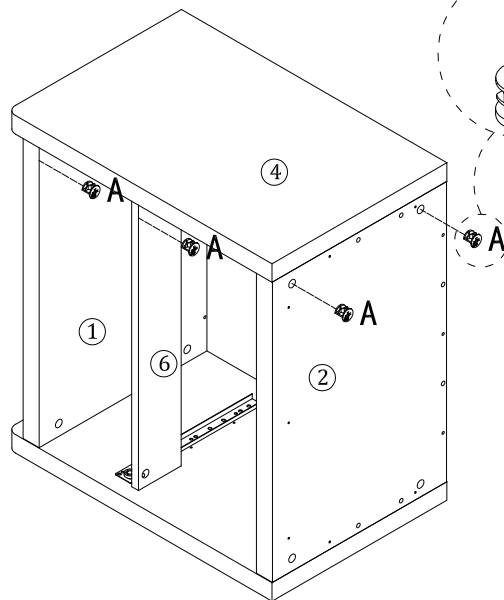
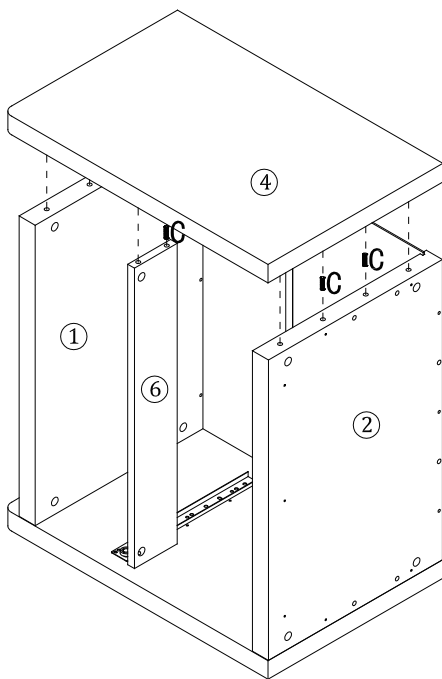

Step 8



C *6	A *5
	

Step 9

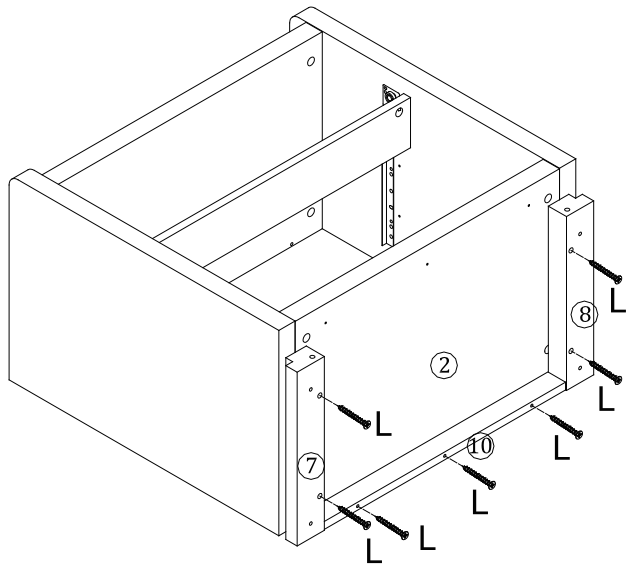
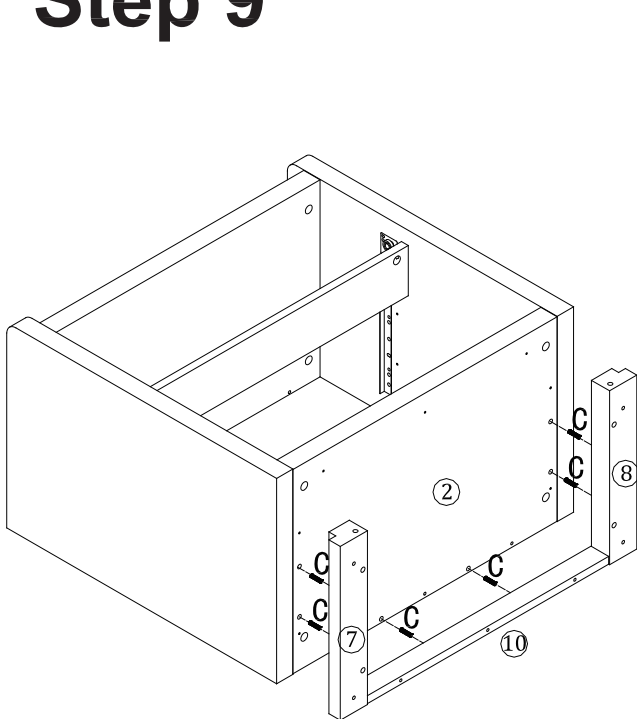

C *6	L *7

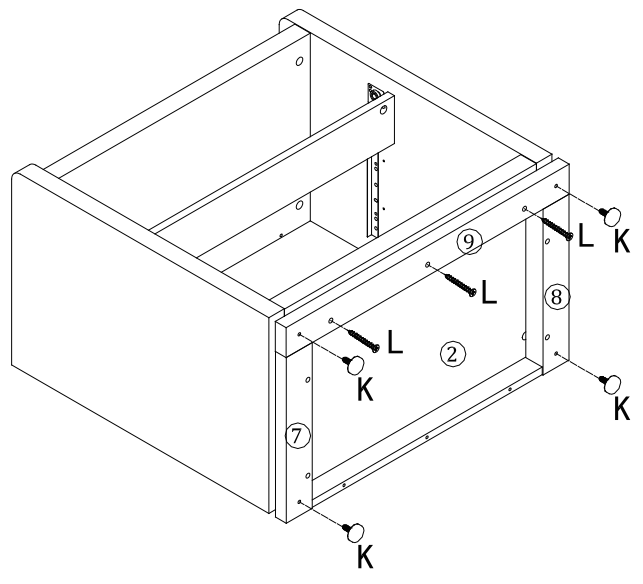
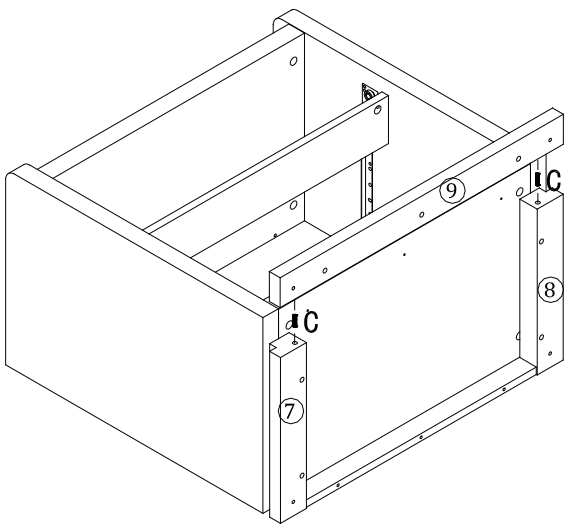

Step 10

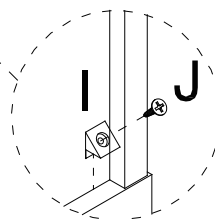
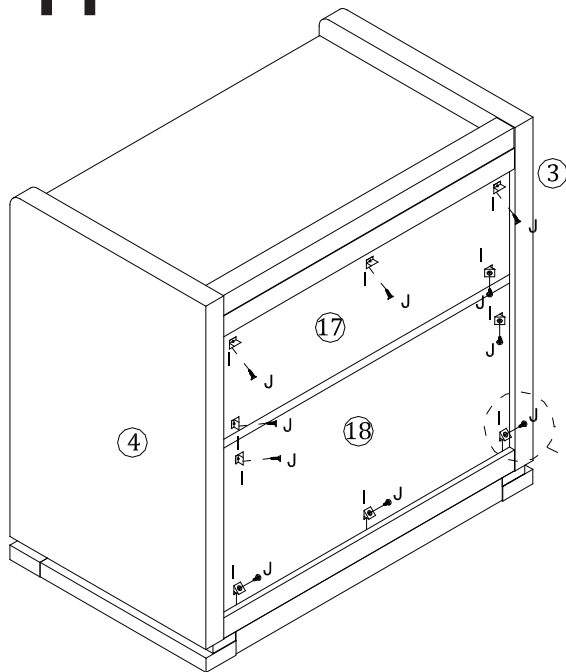

C *2	L *3	K *4

Step 11



J *10	I *10
	

Step 12

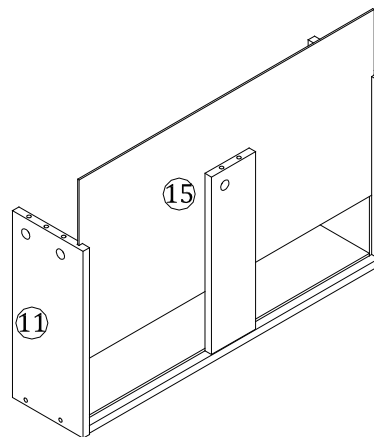
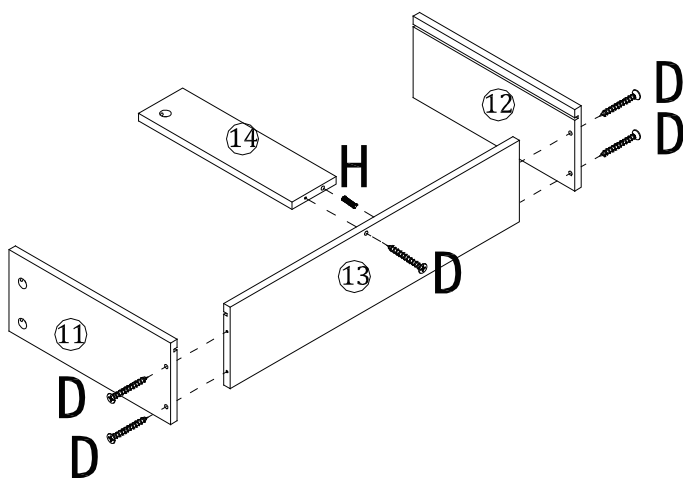

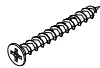
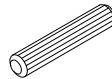
D *5	H *1
	

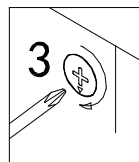
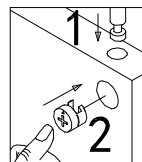
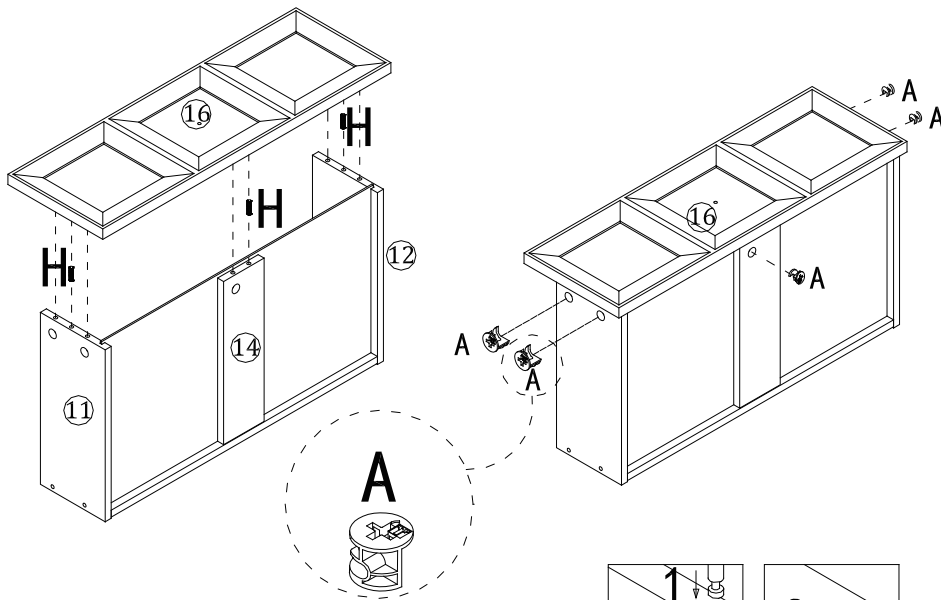

Step 13

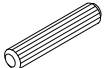

A *5	H *3
	

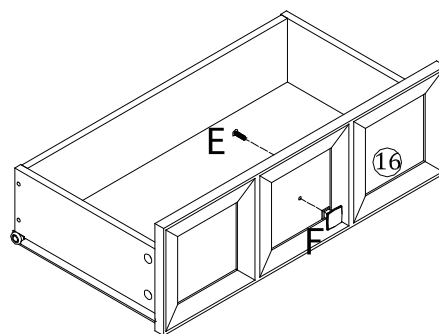
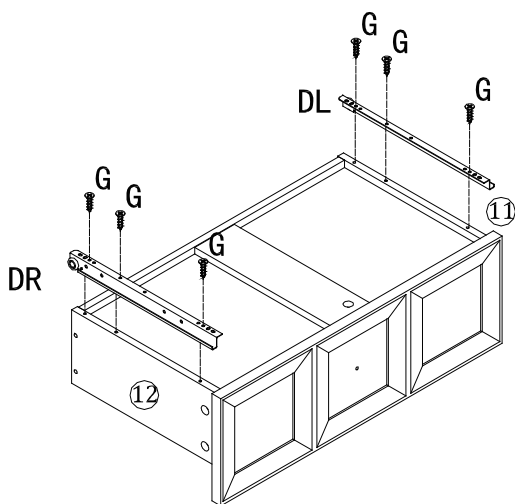
Step 14



E *1	F *1	G *6
		

Step 15

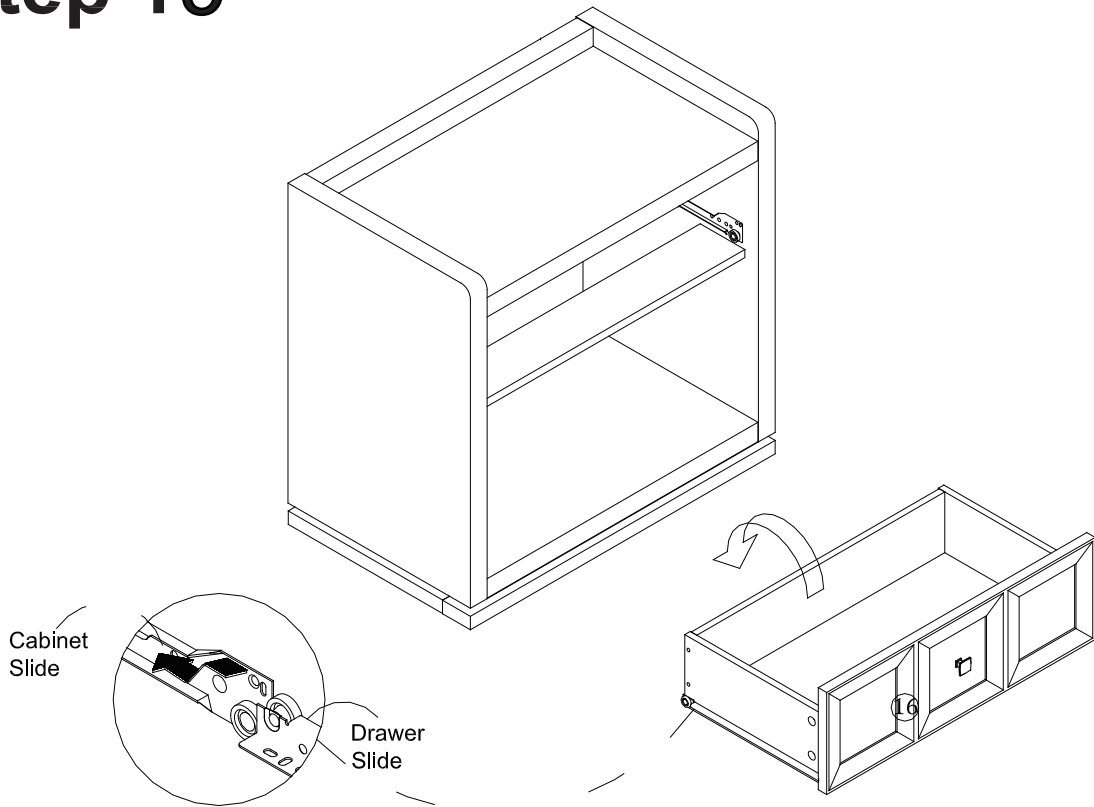

Step 16

