

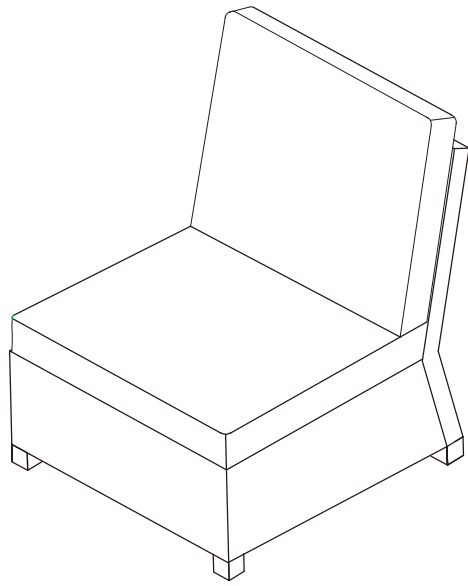

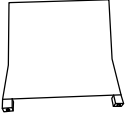

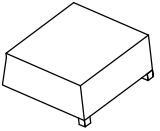



Center Chair



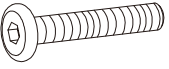
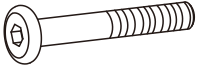

PART LIST

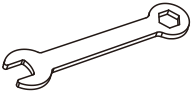
| | | | | |
|--|---|---|--|---|
| A  | B  | C  | D  | E  |
| Back Panel 1 PC | Seat Panel 1 PC | Cover Of Seat Cushion* 1 PC | Inner Of Seat Cushion 1 PC | Cover Of Back Cushion* 1 PC |
| F  <p style="text-align: center;">*Please note cushion covers will ship separately.</p> | | | | |
| Cover Of Back Cushion 1 PC | | | | |

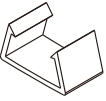
HARDWARE LIST



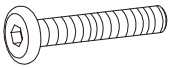
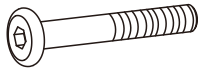

| | | | | |
|---|---|--|---|--|
| G  | H  | I  | J  | K  |
| M6*55mm Short Bolt 4 PCS | M6*65mm Long Bolt 2 PCS | M6mm Nut 2 PCS | M6mm Washer 8 PCS | M6mm Wrench 1 PC |
| L  | M  | | | |
| M6mm Allen Key 1 PC | Plastic Clip 2 PCS | | | |

EXTRA HARDWARE LIST

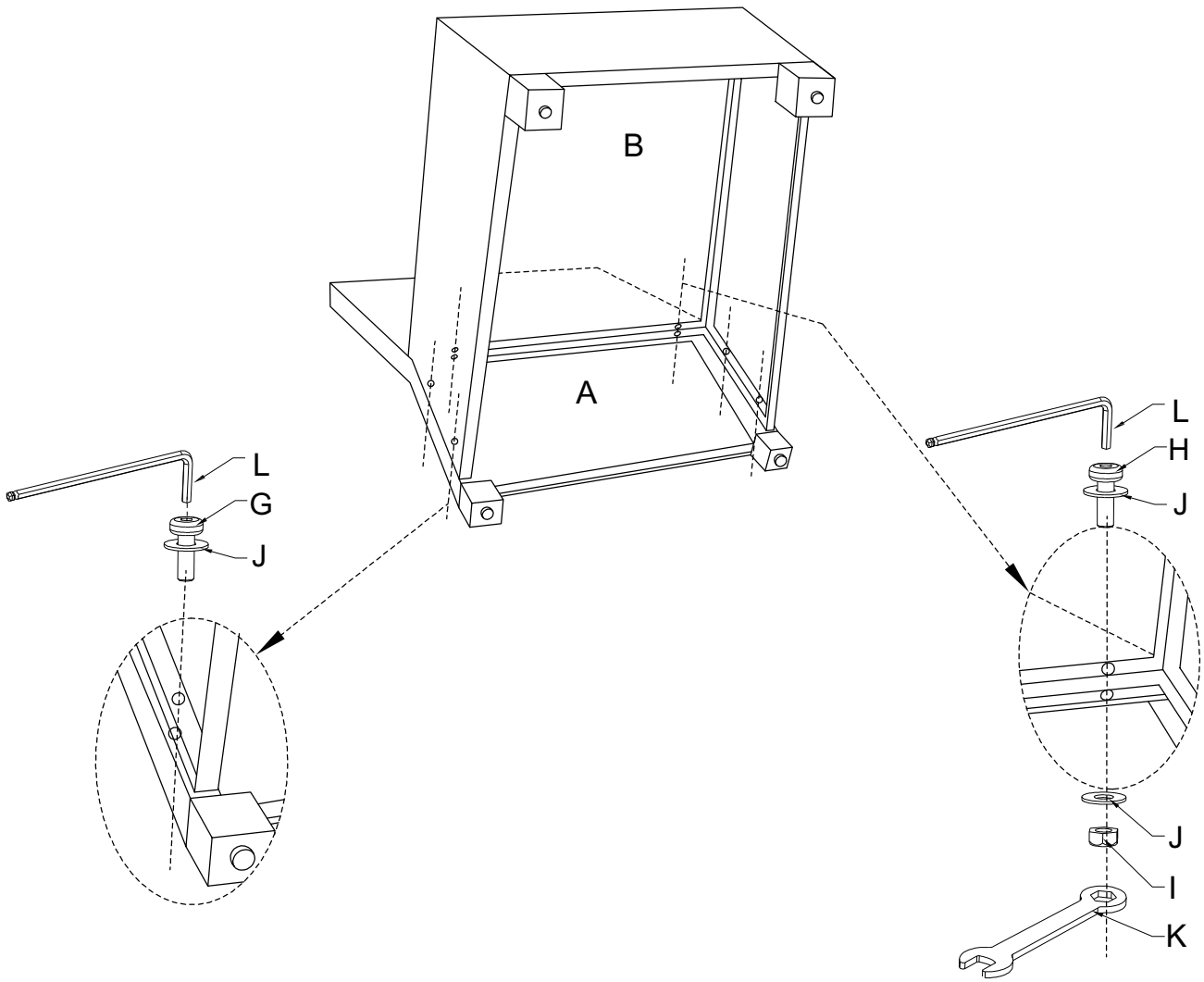
| | | | |
|---|---|---|---|
| G  | H  | I  | J  |
| M6*55mm Short Bolt 1 PCS | M6*65mm Long Bolt 1 PCS | M6mm Nut 1 PCS | M6mm Washer 2 PCS |

Step 1. Lay Back Panel (A) down on a flat surface. Attach Seat Panel(B) to Back Panel(A) using the Short Bolts(G),Long Bolts(H),Washers(J), Nuts(I),Wrench(K) & Allen Key (L).
NOTE: Please do not fully tighten bolts until unit is fully assembled.



- | | | |
|---|---|----|
| G |  | x4 |
| H |  | x2 |
| I |  | x2 |
| J |  | x8 |
| L |  | x1 |

Step 2. Insert Inner Of Seat Cushion (D) into Cover Of Seat Cushion (C).
Insert Inner Of Back Cushion (F) into Cover Of Back Cushion (E).

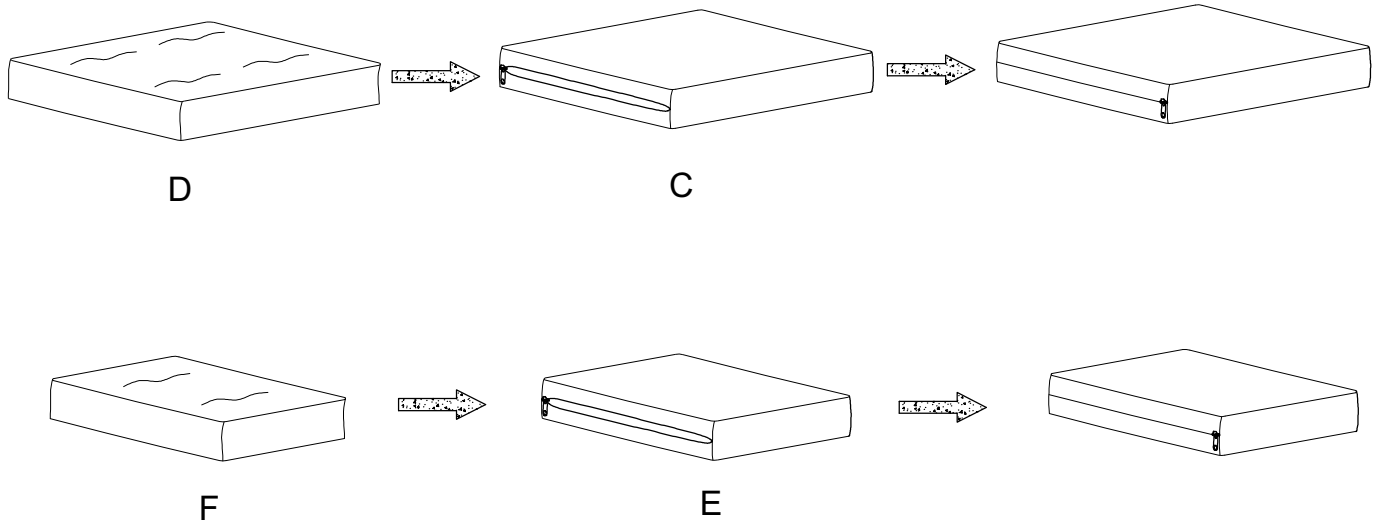

Step 3. Place Seat Cushion and Back Cushion on the chair.

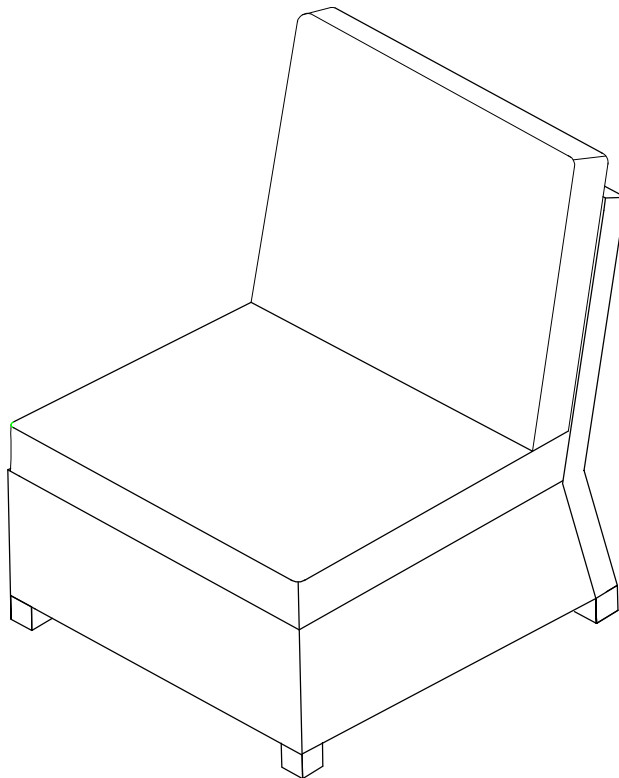

Step 4. Use plastic clips (part M) to secure additional units together as shown.

