

Assembly Instructions

Crossleg Table



PARTS

(A) Table Top (1)

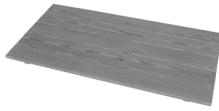

(B) Table Legs (2)



HARDWARE (included)

2" Bolts (4)

(a)



2" Lag Screws (2)

(b)



Allen Wrench (1)

(c)



TOOLS NEEDED

$\frac{7}{16}$ " Wrench or Socket

STEP 1

Lay table top upside down on a clean surface. Unfold table legs creating an X. Place legs on table top with one side outside 2x2 on table top & other side inside 2x2. Angle brace belongs toward center of top. Put a 2" bolt through the predrilled hole in each leg & turn into the threaded inserts in the 2x2 strip. Tighten with the Allen wrench. The bolts go in opposite sides, always put through the leg first.

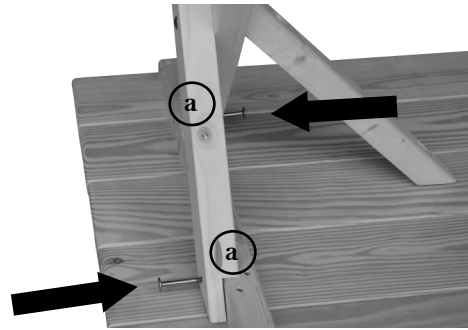
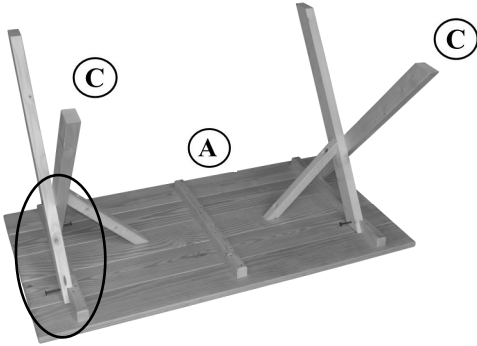

STEP 2

Attach the leg braces to the table top. Place the braces in the center of the board & attach with 2" lag screws using a $\frac{7}{16}$ " wrench or socket. Holes are not predrilled as lags are self drilling.

