

Kitchen Island Cart

Assembly Instructions - Please keep for future reference

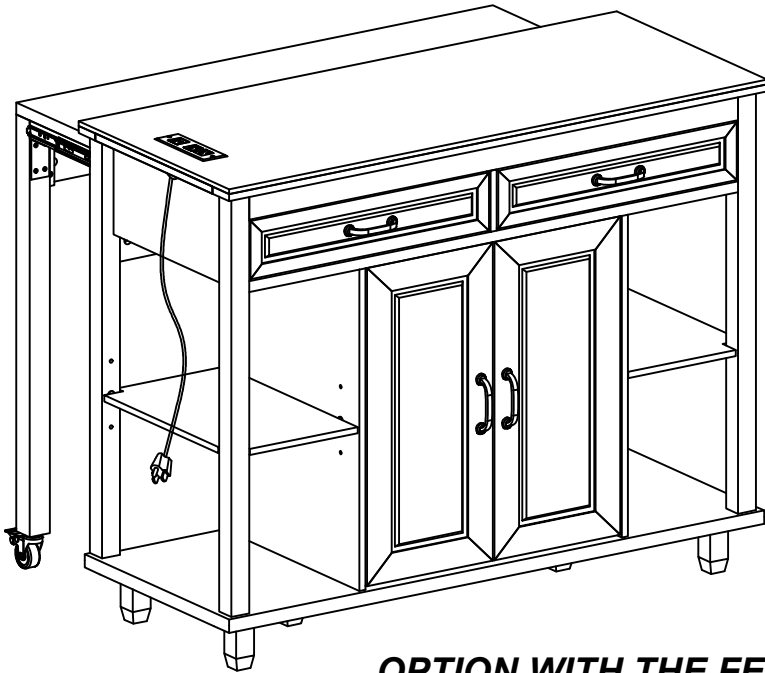

OPTION WITH THE FEET

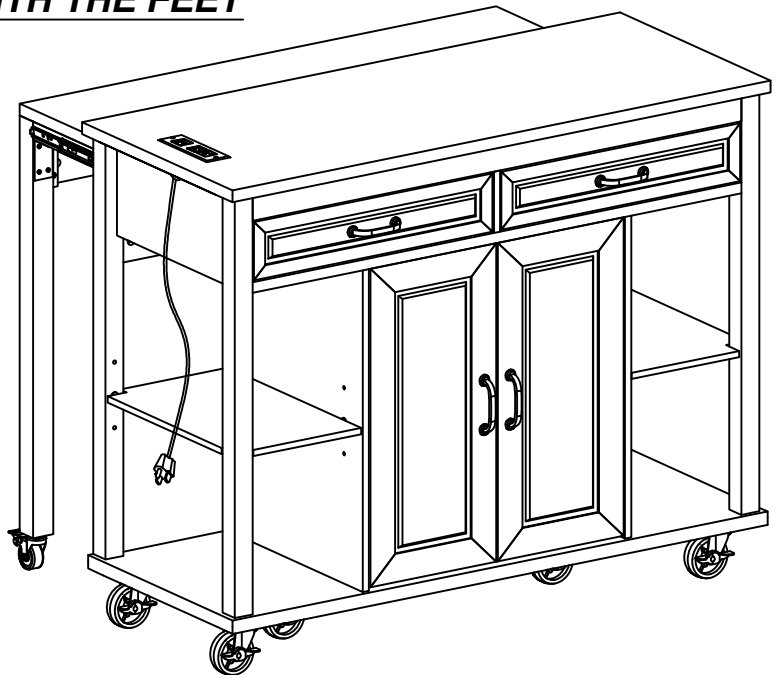

OPTION WITH THE WHEELS

Important - Please read these instructions fully before starting assembly



Safety and Care Advice

Important – Please read these instructions fully before starting assembly

- Check you have all the components and tools listed on the following pages.
- Remove all fittings from the plastic bags and separate them into their groups.
- Keep children and animals away from the work area, small parts could choke if swallowed.
- Make sure you have enough space to layout the parts before starting.

- During assembly do not stand or put weight on the product, this could cause damage.
- Assemble the item as close to its final position (in the same room) as possible.
- Assemble on a soft level surface to avoid damaging the unit or your floor.
- Parts of the assembly will be easier with 2 people.



power drill is set on a low torque setting.

- To reduce the likelihood of damaging your product please ensure that your

Care and maintenance

- Only clean using a damp cloth and mild detergent, do not use bleach or abrasive cleaners.
- From time to time check that there are no loose screws on this unit.
- This product should not be discarded with household waste. Take to your local authority waste disposal centre.

Handy Hints

- Assemble all parts and bolts loosely during assembly, only once the product is complete should you fully tighten the bolts
- Regularly check and ensure That all bolts and fittings are tightened properly.

WARNING
In order to help prevent overturning – please follow these instructions

To help prevent product toppling over please follow the below steps:-





- Use the anti tip stap or wall fixing method provided (if applicable)
- Do not allow children to climb or hang on the furniture
- Do not open more than one drawer at a time
- Do not place heavy items in the top drawers
- Do not place heavy items on top of the furniture, unless the furniture has been designed for this purpose

Components - Fittings

Please check you have all the panels listed below

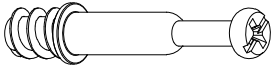
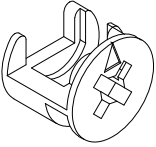
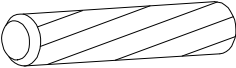
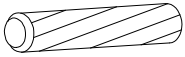
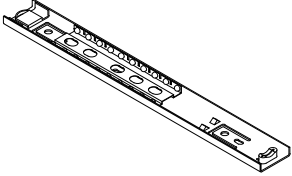
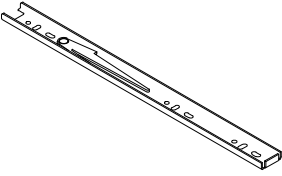
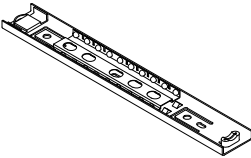
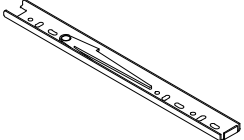
Note: The quantities below are the correct amount to complete the assembly. In some cases, more fittings may be supplied than required.

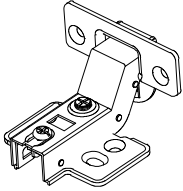
HARDWARE BOX INSIDE BOX 2

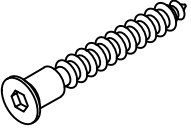
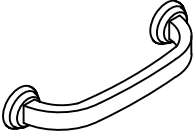
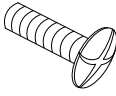
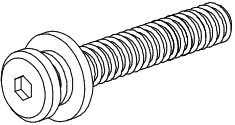
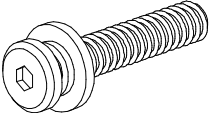
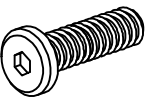
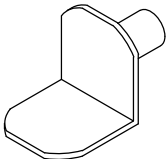
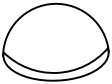

<p>A QTY: 39</p> 	<p>B QTY: 39</p> 	<p>C QTY: 14</p>  <p>Ø8*30mm</p>	<p>D QTY: 12</p>  <p>Ø6*30mm</p>
CAM BOLT	CAM LOCK	WOOD DOWEL	WOOD DOWEL
<p>E1 QTY: 2</p>  <p>L=300*35mm</p>	<p>E2 QTY: 2</p>  <p>L=300*35mm</p>	<p>F1 QTY: 4</p>  <p>L=250*35mm</p>	<p>F2 QTY: 4</p>  <p>L=250*35mm</p>
BALL BEARING GLIDE	BALL BEARING GLIDE	BALL BEARING GLIDE	BALL BEARING GLIDE
<p>G QTY: 36</p>  <p>Ø6*12mm</p>	<p>H QTY: 4</p> 	<p>I QTY: 26</p>  <p>Ø7*12mm</p>	<p>J QTY: 12</p>  <p>Ø8*25mm</p>
FLAT HEAD SCREW	HINGES	FLAT HEAD SCREW	FLAT HEAD SCREW
<p>K QTY: 22</p>  <p>Ø10*45mm</p>	<p>L QTY: 4</p> 	<p>M QTY: 8</p>  <p>Ø8*18mm</p>	<p>N QTY: 4 SET</p>  <p>Ø1/4*45mm</p>
ALLEN FLAT HEAD SCREW	HANDLE	BOLT	BOLT
<p>O QTY: 14 SET</p>  <p>Ø1/4*32mm</p>	<p>P QTY: 24</p>  <p>Ø1/4*12mm</p>	<p>Q QTY: 12</p> 	<p>R QTY: 4</p> 
BOLT	BOLT	SHELF PIN	RUBBER STOPPER

Components - Fittings

Please check you have all the panels listed below

Note: The quantities below are the correct amount to complete the assembly. In some cases, more fittings may be supplied than required.

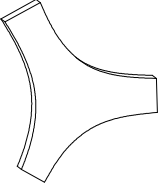
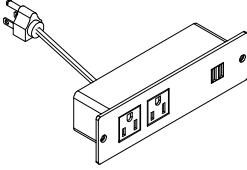
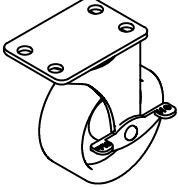
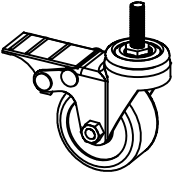
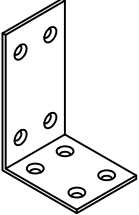
HARDWARE BOX INSIDE BOX 2

<p>S QTY: 1</p> 	<p>T QTY: 1</p> 	<p>U QTY: 1</p> 	<p>V QTY: 6</p> 
<p>ALLEN WRENCH</p>	<p>CAM TOOL</p>	<p>SOCKET</p>	<p>LOCK CASTER</p>
<p>W QTY: 2</p> 	<p>X QTY: 4</p> 	<p>Y QTY: 32</p>  <p>Ø7*15mm</p>	
<p>LOCK CASTER</p>	<p>METAL BRACKET</p>	<p>FLAT HEAD SCREW</p>	

Using Camlocks

Step 1

Connect the male camlock as directed in the assembly instructions using a screwdriver.

1

DO NOT OVER TIGHTEN.
NE PAS SERRER EXCESSIVEMENT.

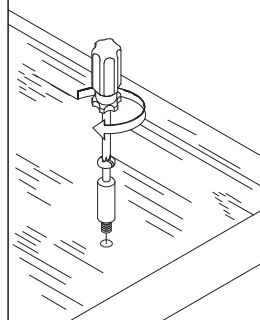

Step 2

Push the male camlock into the entry hole.

2

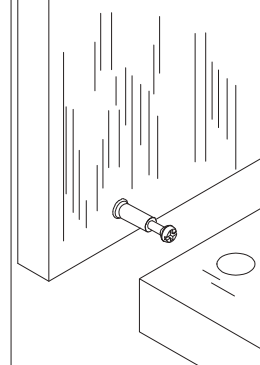

Step 3

Insert the female camlock as shown in the instruction.

Note: ensure that the arrow on the top of the camlock points towards the entry hole for the male camlock.

3

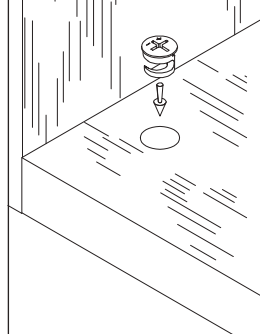

Step 4

Turn the female camlock clockwise with a screwdriver.

You should feel a click when the camlock is locked in place.

The joint is now secure.

4

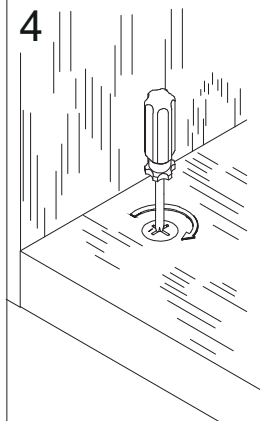

COMPONENTS - KEY DIAGRAM

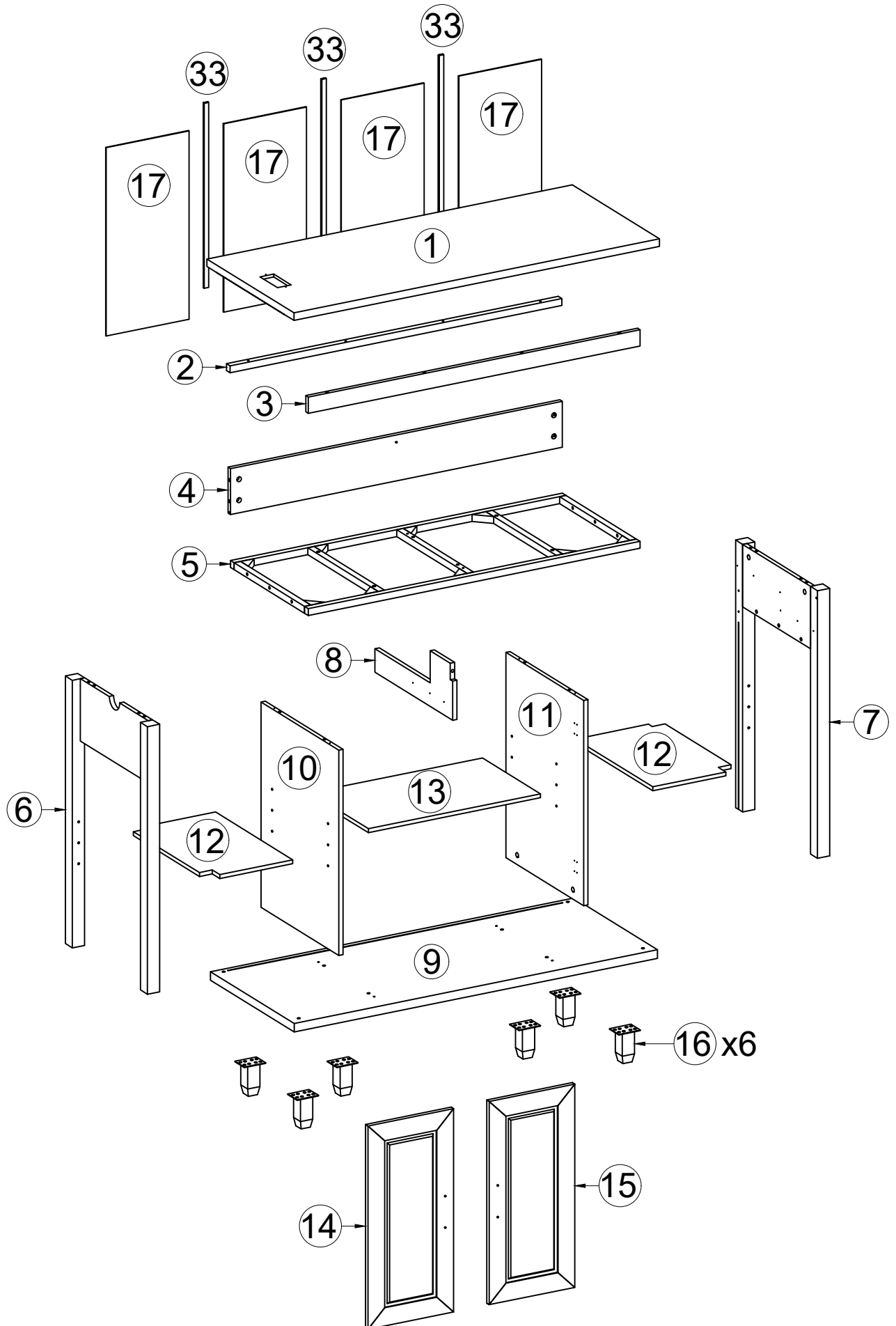

COMPONENTS - KEY DIAGRAM

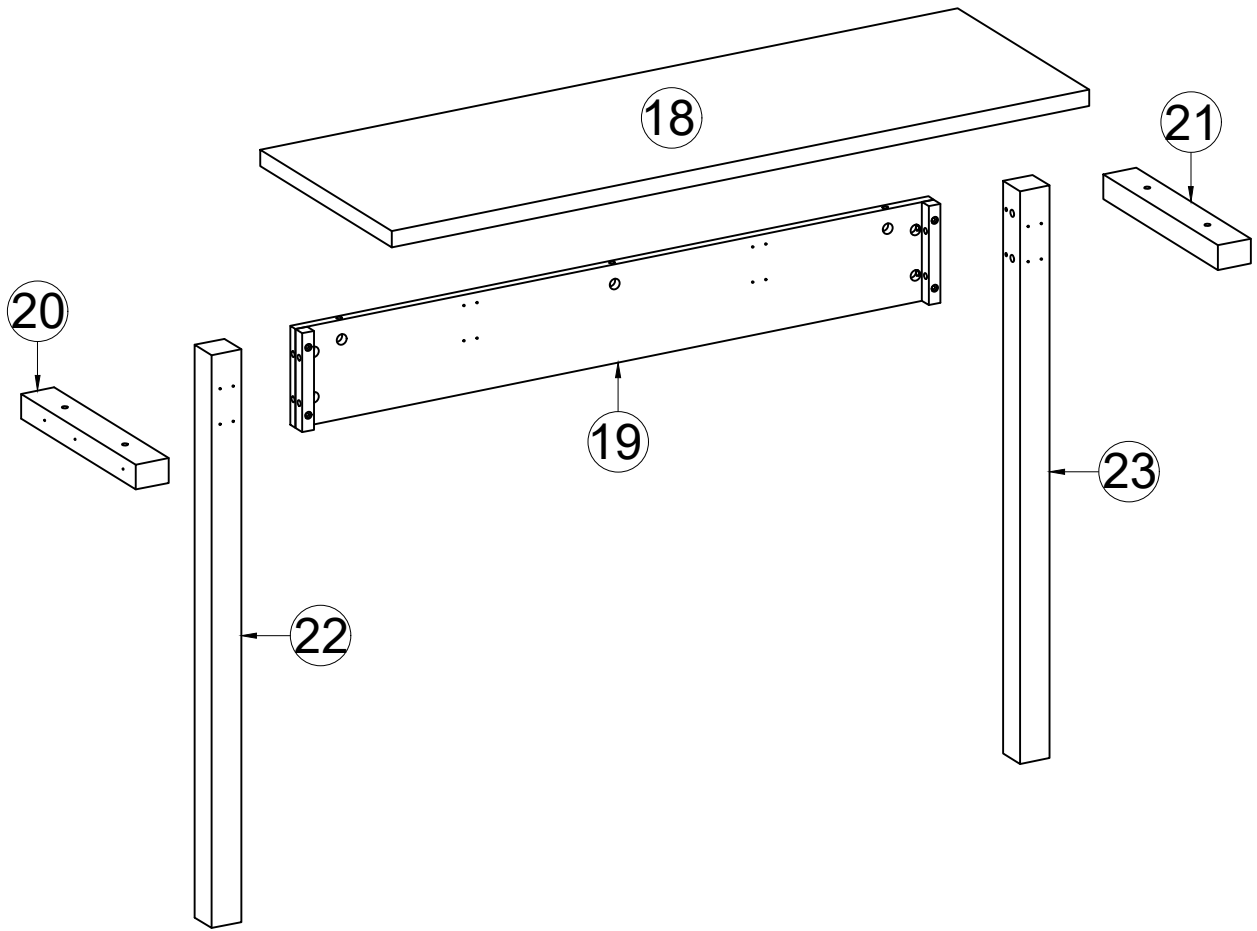

x2pcs

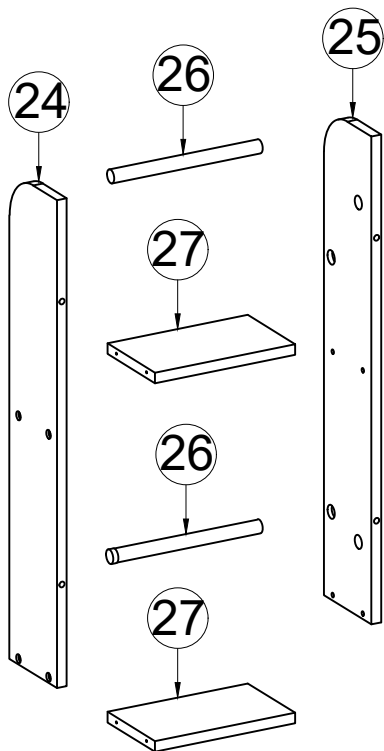

x2pcs

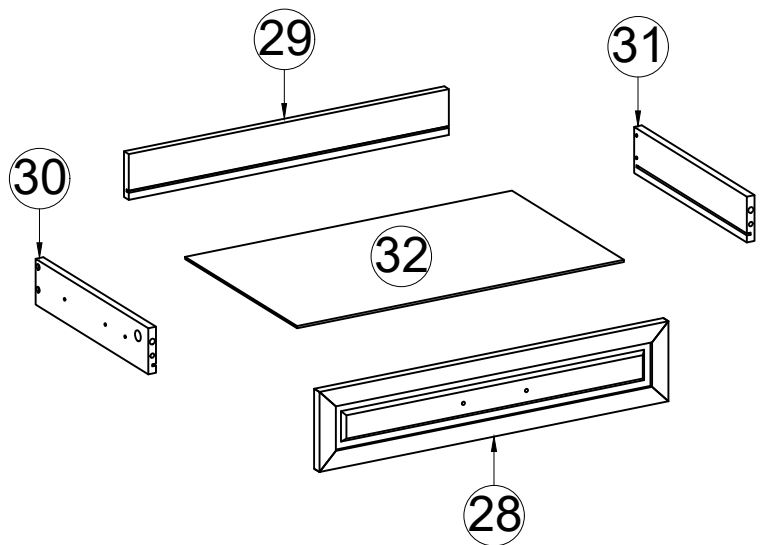

COMPONENTS - KEY DIAGRAM

BOX 1

6

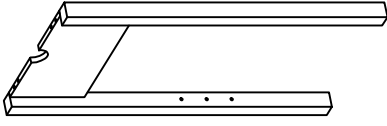

LEFT FRAME

QTY: 1

7

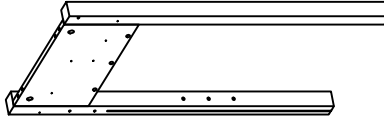

RIGHT FRAME

QTY: 1

13

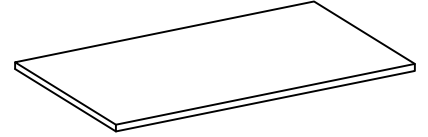

MIDDLE SHELF

QTY: 1

14



LEFT DOOR

QTY: 1

15

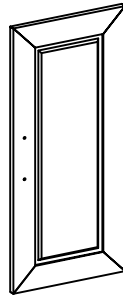

RIGHT DOOR

QTY: 1

17

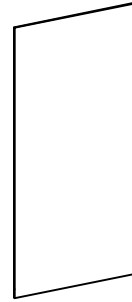

BACK PANEL

QTY: 4

20

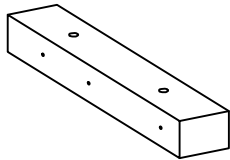

QTY: 1

21

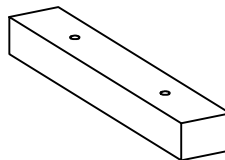

QTY: 1

22

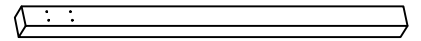

EXTENDED TOP SUPPORT - LEFT

EXTENDED TOP SUPPORT - RIGHT

BACK LEFT LEG

QTY: 1

23

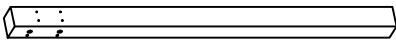

BACK RIGHT LEG

QTY: 1

24



LEFT STAND SHELF DOOR

QTY: 2

25

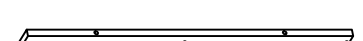

RIGHT STAND SHELF DOOR

QTY: 2

28

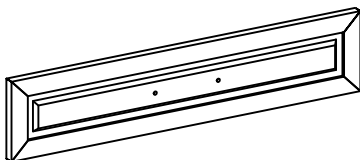





DRAWER FRONT

QTY: 2

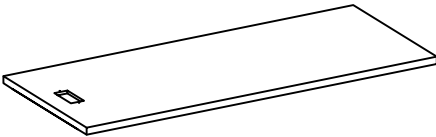
COMPONENTS - KEY DIAGRAM

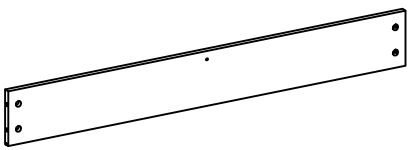
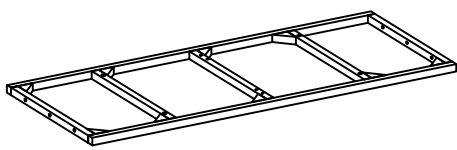
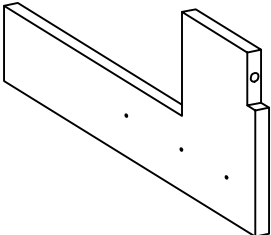
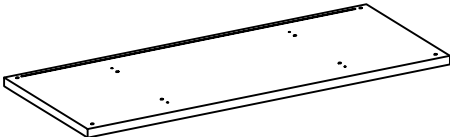
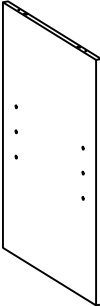
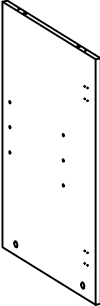
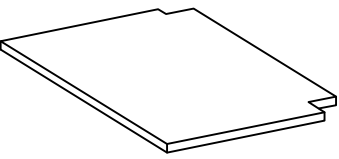
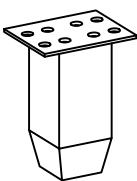
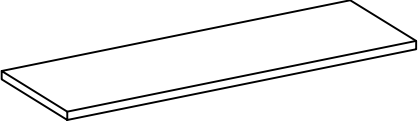
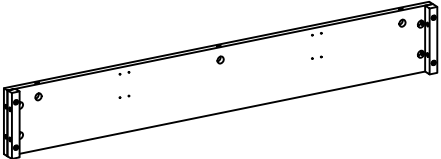
BOX 2

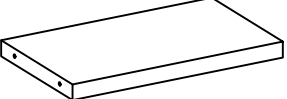
<p>1</p> 	<p>2</p> 	<p>3</p> 
<p>TOP PANEL QTY: 1</p>	<p>TOP BACK RAIL QTY: 1</p>	<p>FRONT RAIL QTY: 1</p>
<p>4</p> 	<p>5</p> 	<p>8</p> 
<p>BACK RAIL QTY: 1</p>	<p>MIDDLE FRAME QTY: 1</p>	<p>TOP PARTITION QTY: 1</p>
<p>9</p> 	<p>10</p> 	<p>11</p> 
<p>BOTTOM PANEL QTY: 1</p>	<p>BOTTOM LEFT PARTITION QTY: 1</p>	<p>BOTTOM RIGHT PARTITION QTY: 1</p>
<p>12</p> 	<p>16</p> 	<p>18</p> 
<p>SIDE SHELF QTY: 2</p>	<p>LEG QTY: 6</p>	<p>EXTENDED TOP PANEL QTY: 1</p>
<p>19</p> 	<p>26</p> 	<p>27</p> 
<p>BACK FRAME QTY: 1</p>	<p>PULL BAR SHELF DOOR QTY: 4</p>	<p>SHELF DOOR QTY: 4</p>

COMPONENTS - KEY DIAGRAM

BOX 2

29



30

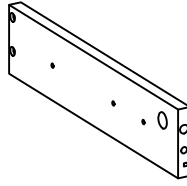

31

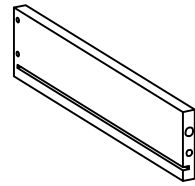

DRAWER BACK

QTY: 2

DRAWER SIDE - LEFT

QTY: 2

DRAWER SIDE - RIGHT

QTY: 2

32

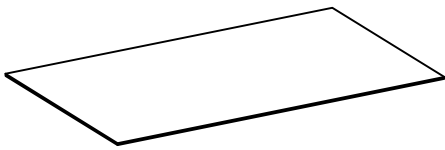

33

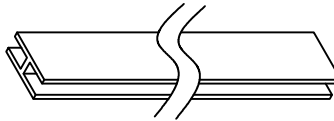

DRAWER BOTTOM

QTY: 2

PLASTIC SPLINT

QTY: 3

**Slides Must Be Separated Before Assembly.
After Separated, Set Aside Until Needed for Assembly.**

Las diapositivas deben separarse antes del montaje.
Después de la separación, déjelo a un lado hasta que sea necesario.

Les glissières doivent être séparées avant l'assemblage.
Après la séparation, mettez de côté jusqu'au moment de l'assemblage.

**Pay attention when connecting !
The sliding module must be at the front end.**

**STEP 1 : Extend Slide
Extender la diapositiva**

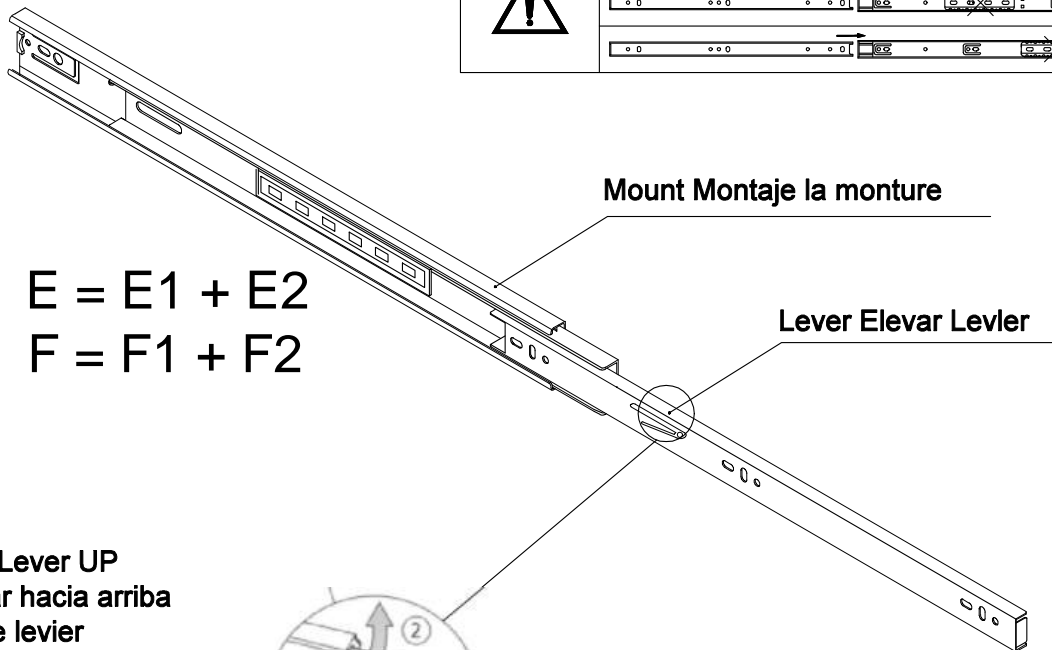

**STEP 2: Push Lever UP
Empujar hacia arriba
Lever le levier**



**Push lever for the left of drawer ,
press the lever for the right of drawer.**

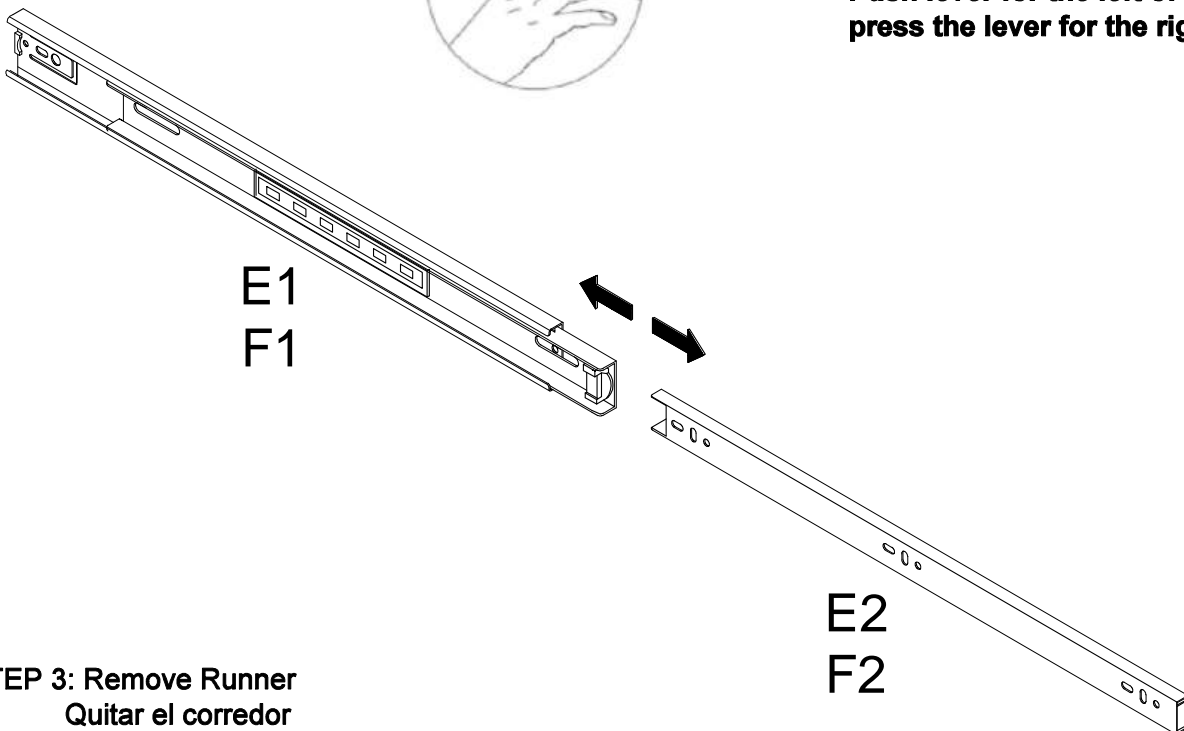

**STEP 3: Remove Runner
Quitar el corredor
Enlever le coureur**

ASSEMBLY INSTRUCTIONS

STEP 1

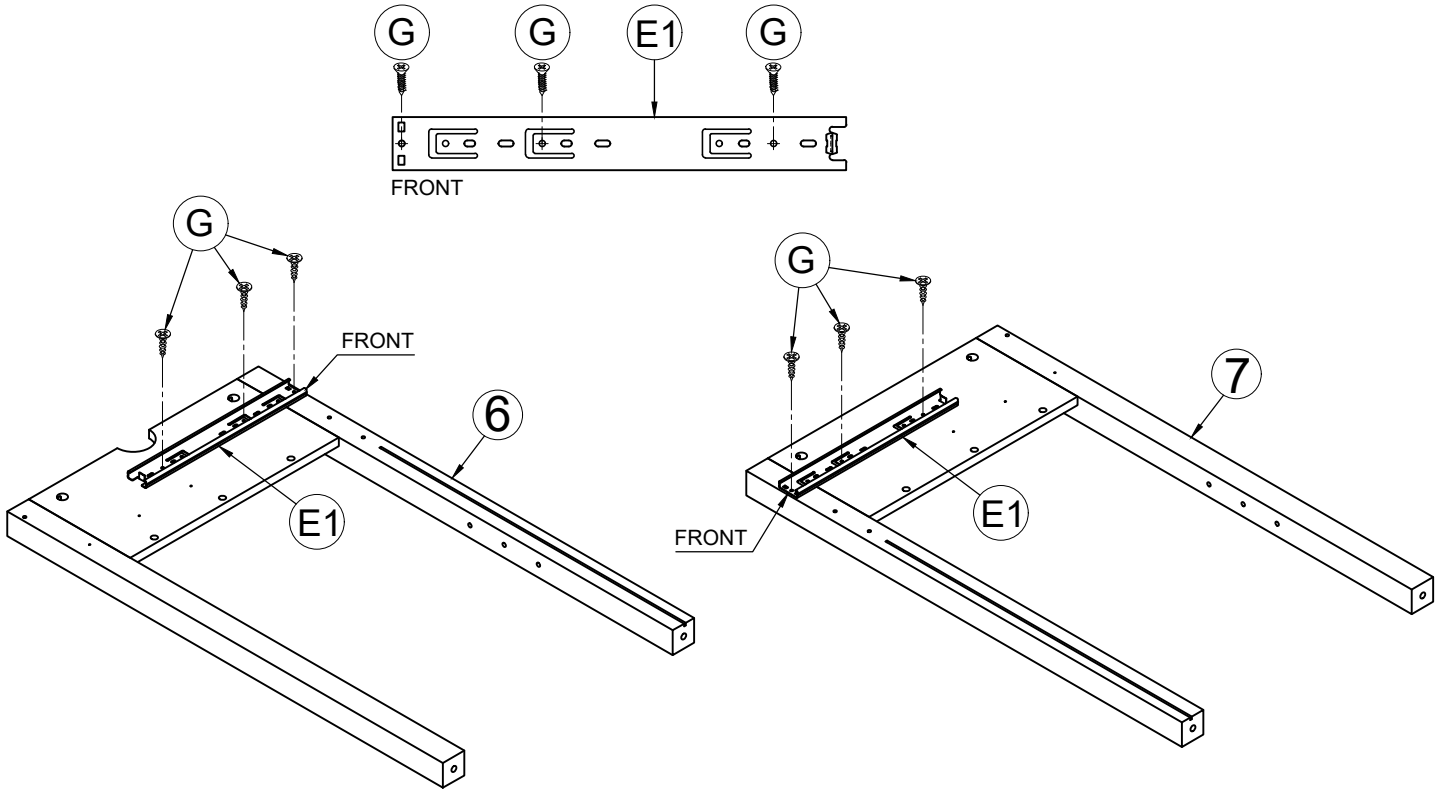

E1		2PCS
G		6PCS

STEP 2

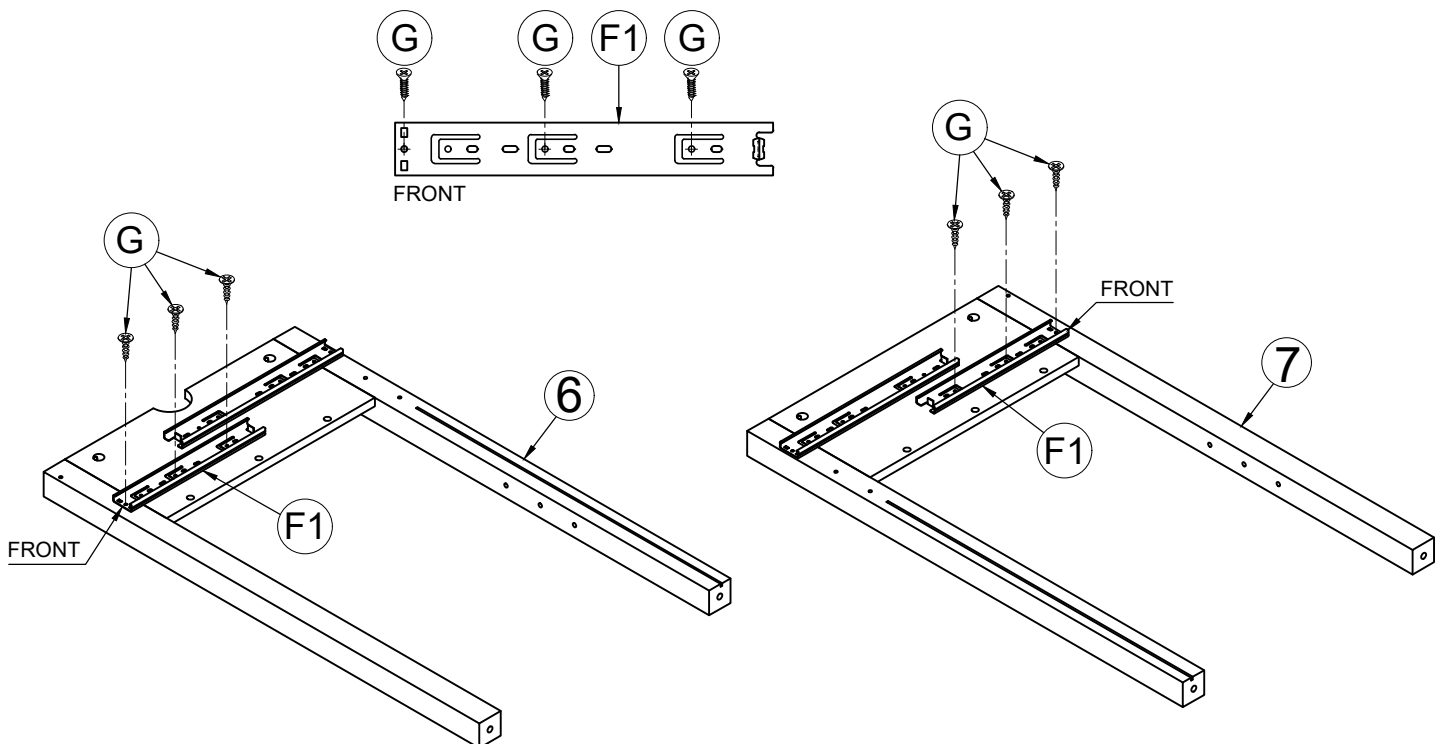

F1		2PCS
G		6PCS

ASSEMBLY INSTRUCTIONS

STEP 3

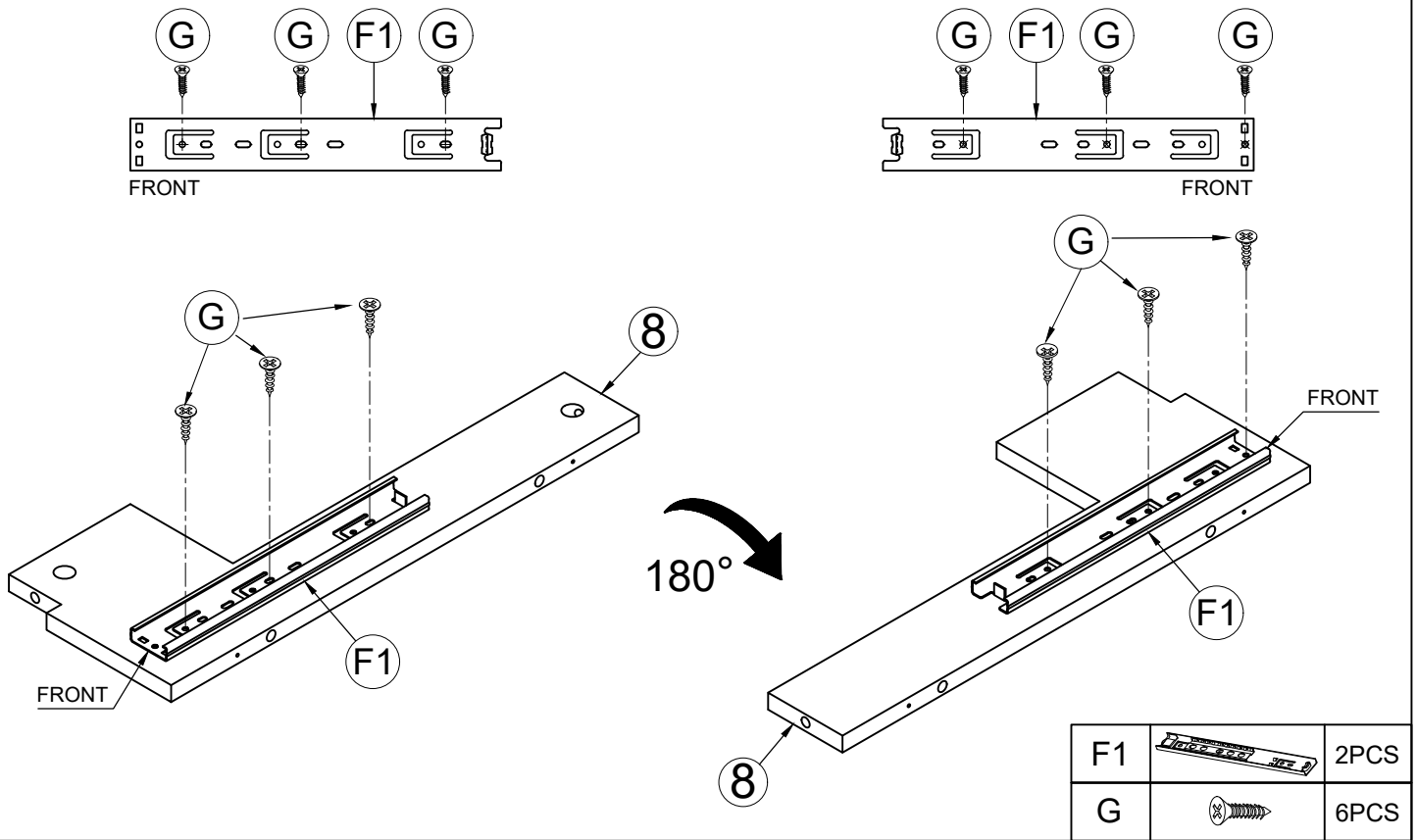

STEP 4

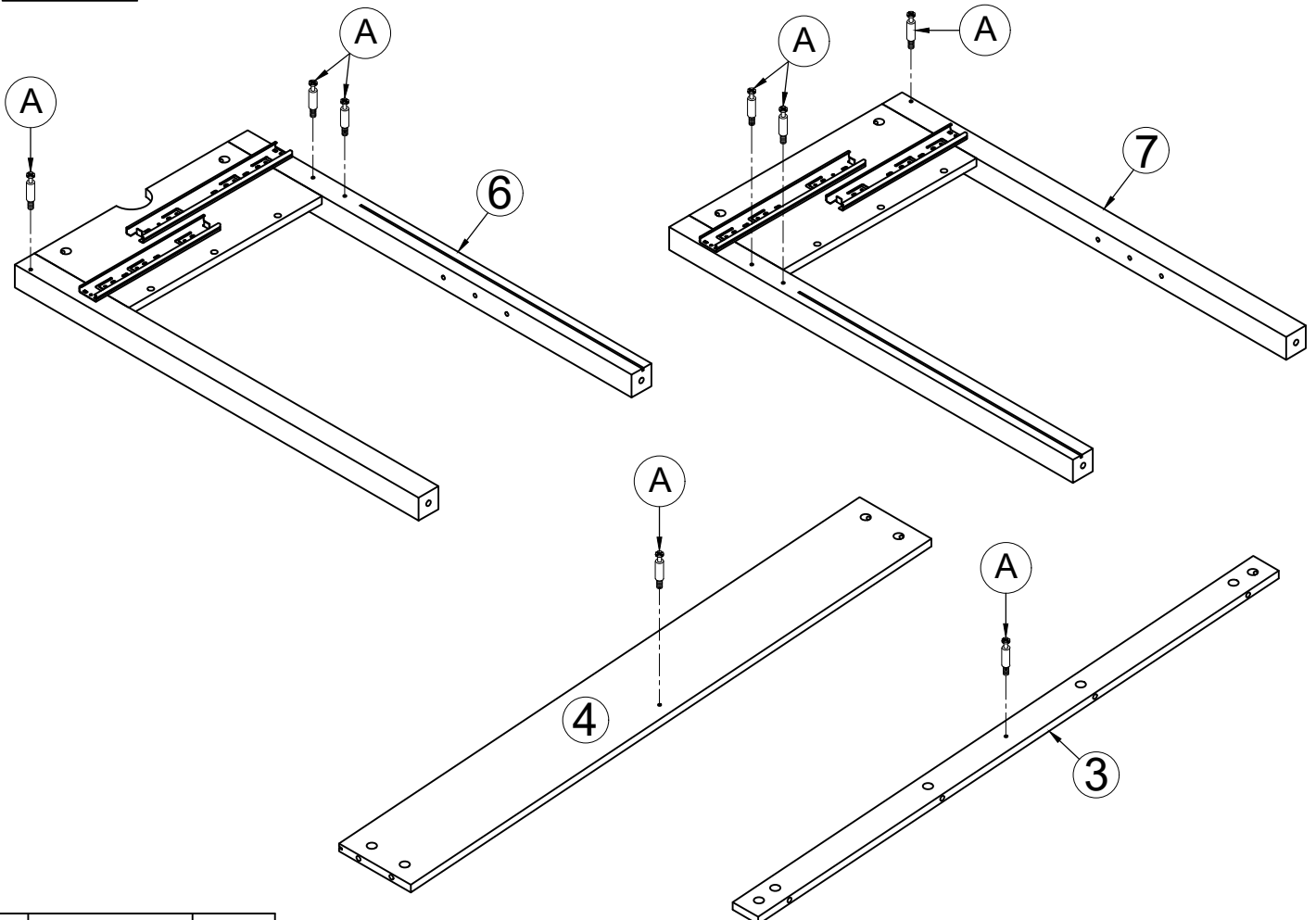

A		8PCS
---	--	------

ASSEMBLY INSTRUCTIONS

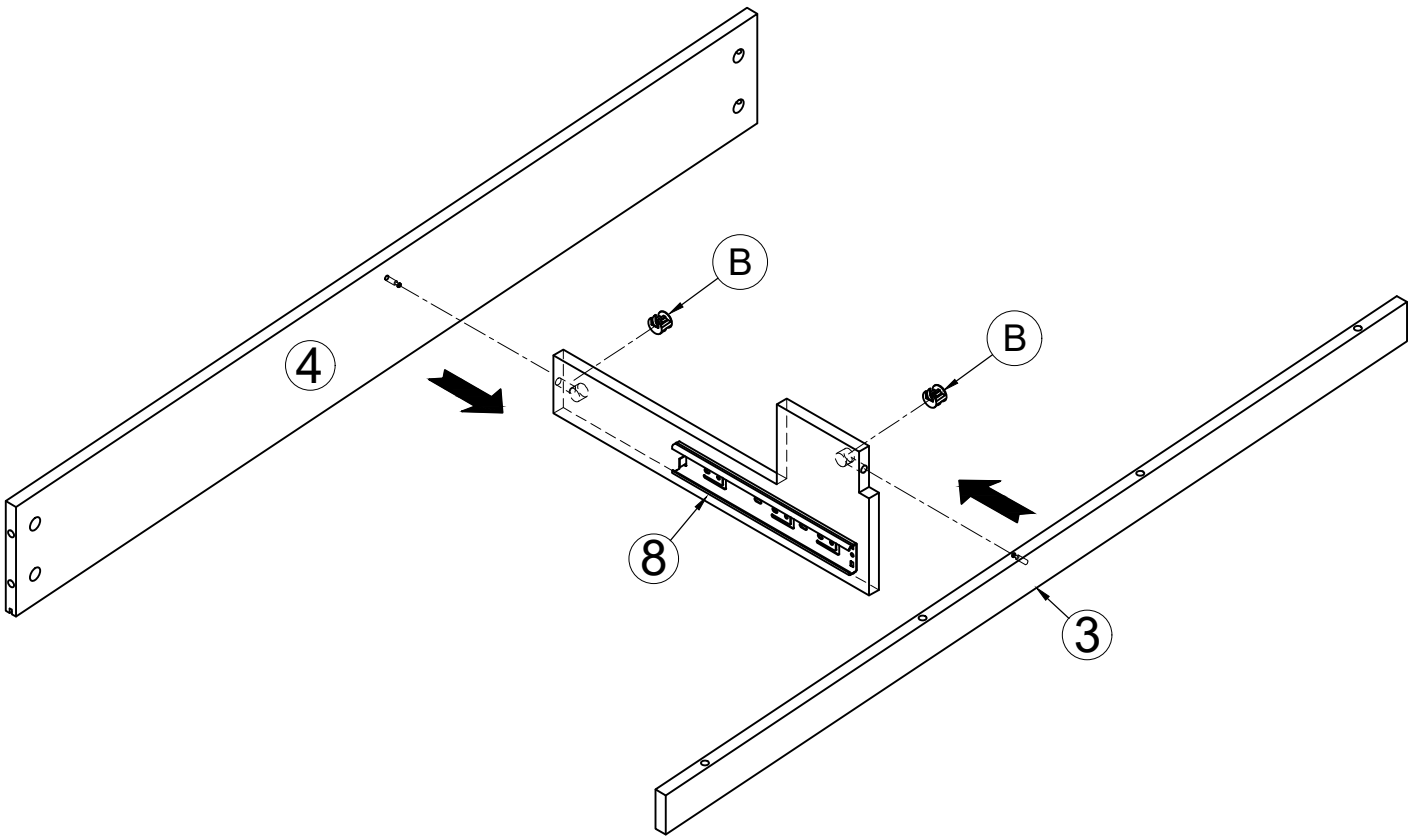

STEP 5

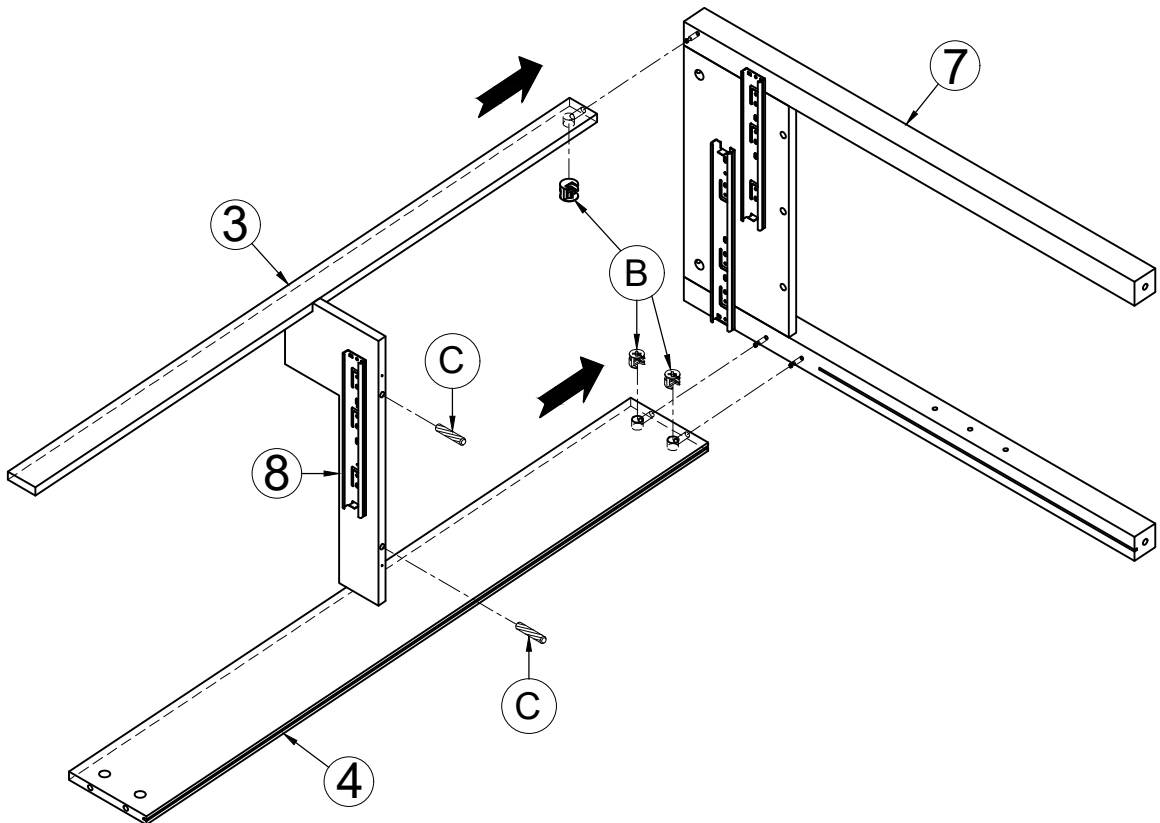

B		2PCS
---	---	------

STEP 6



B		3PCS
C		2PCS

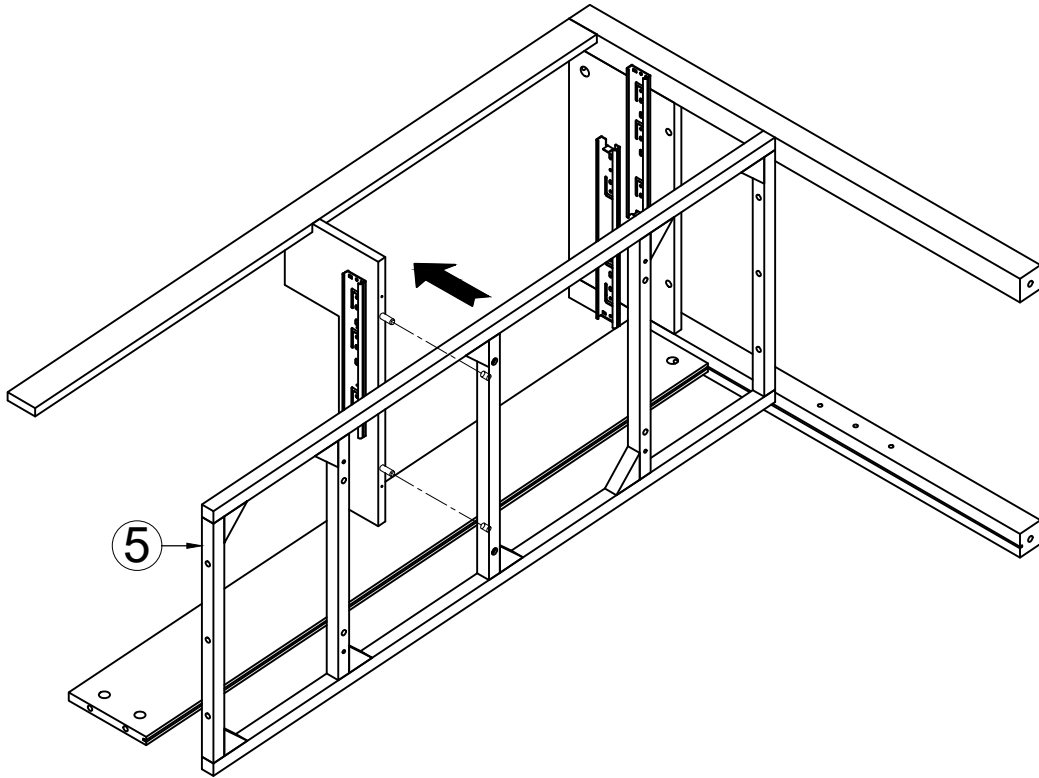

ASSEMBLY INSTRUCTIONS

STEP 7

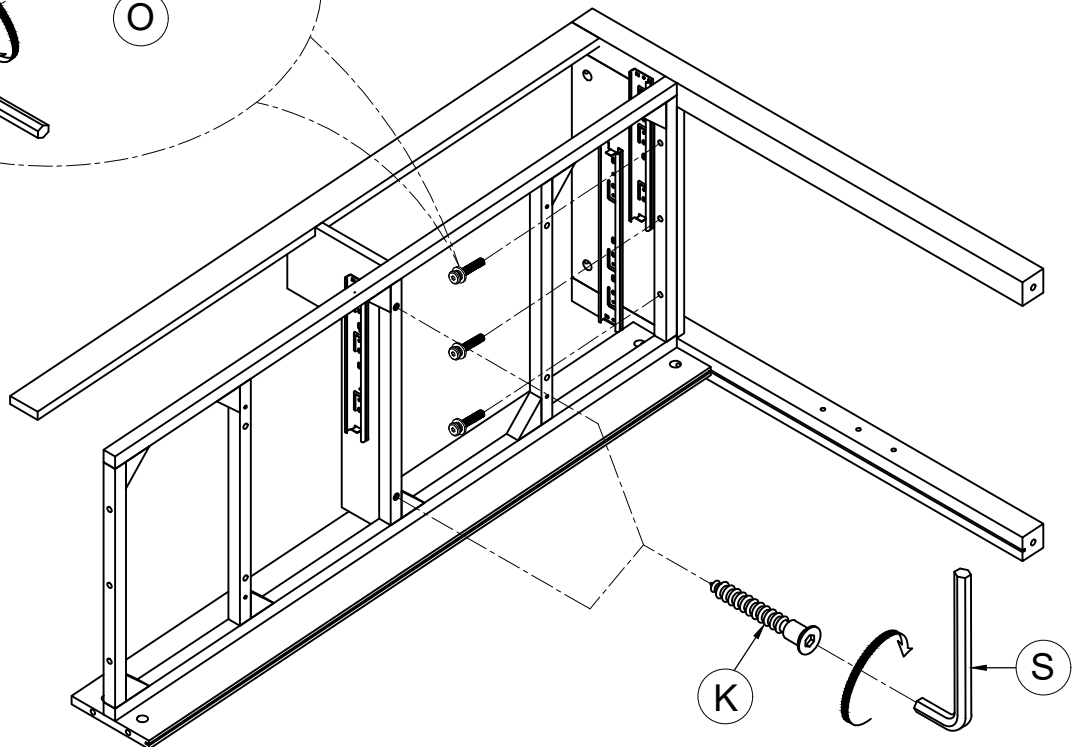
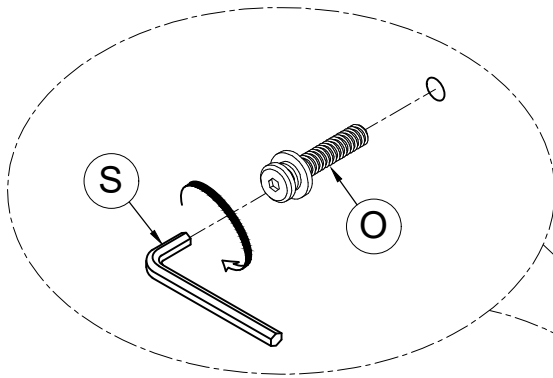

STEP 8

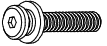



O		3PCS
K		2PCS
S		1PC

ASSEMBLY INSTRUCTIONS

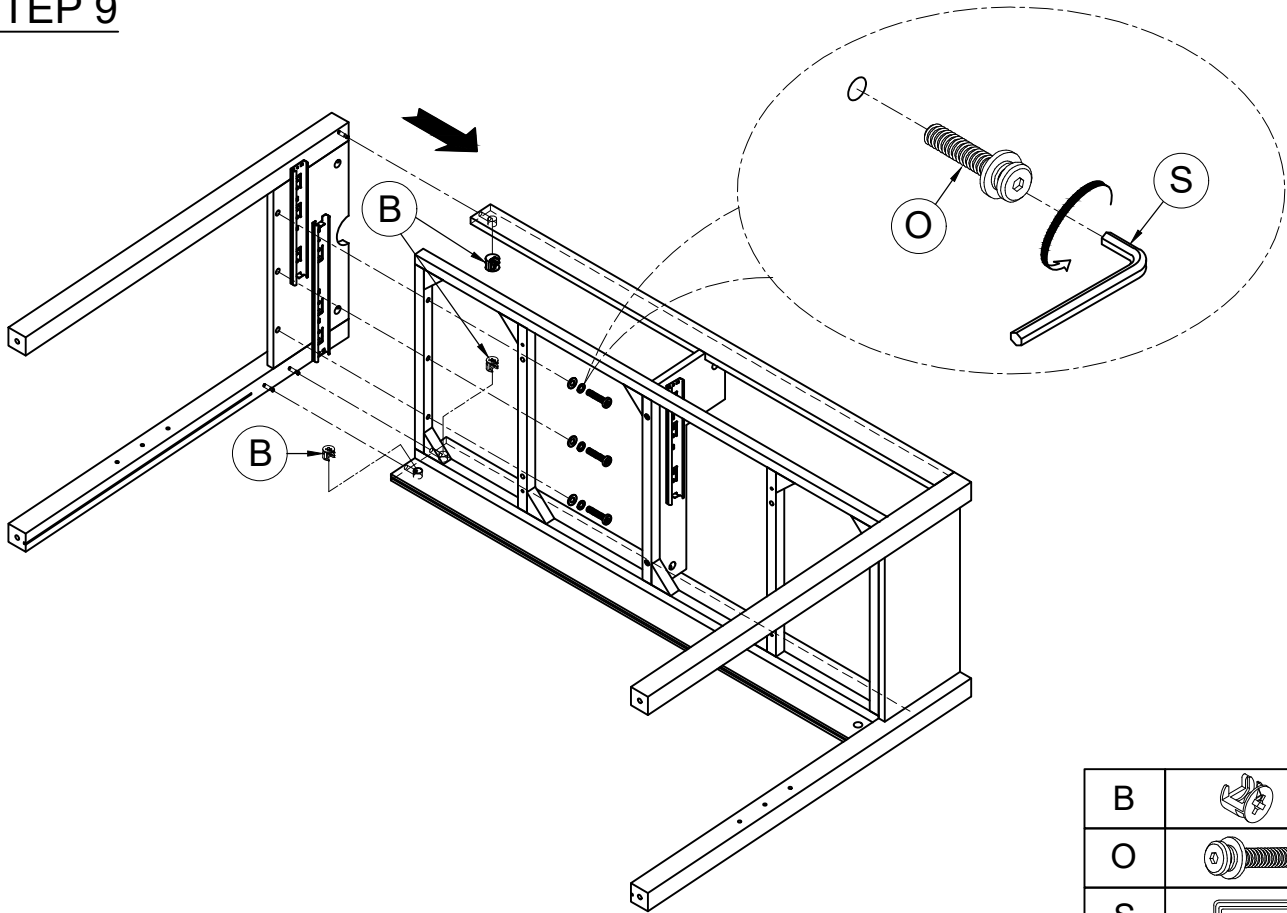

STEP 9

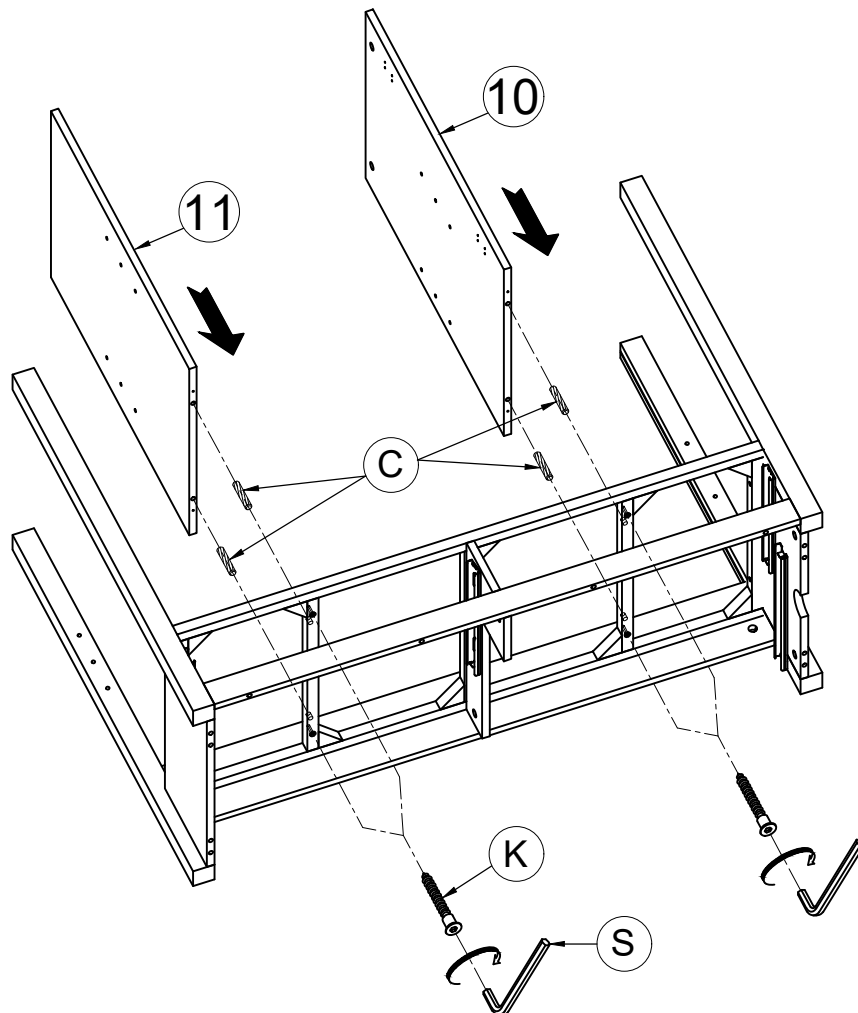

B		3PCS
O		3PCS
S		1PC

STEP 10



C		4PCS
K		4PCS
S		1PC

ASSEMBLY INSTRUCTIONS

STEP 11

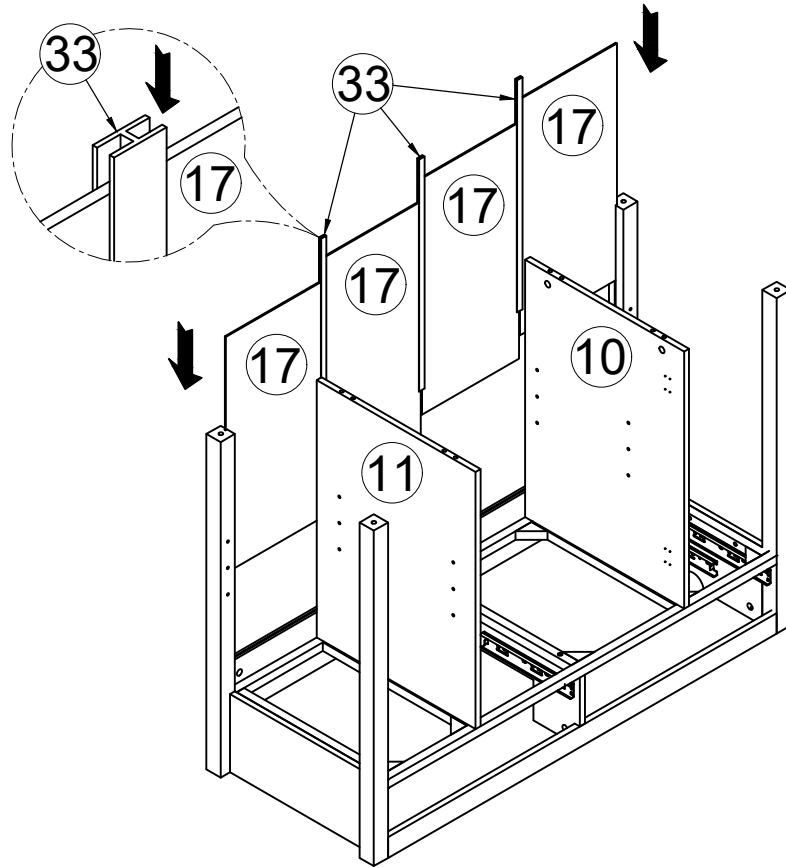

STEP 12

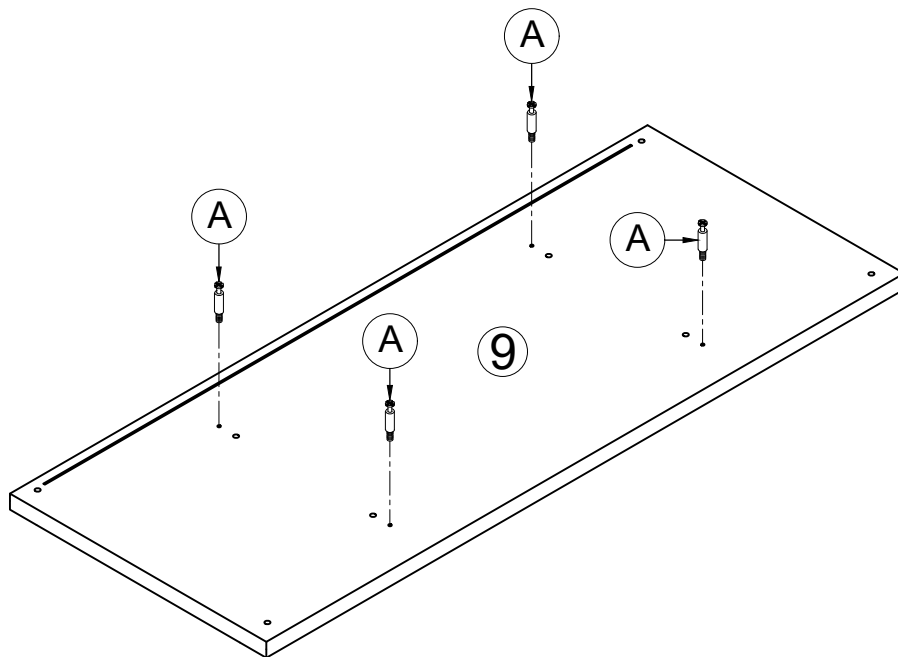

A

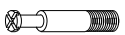



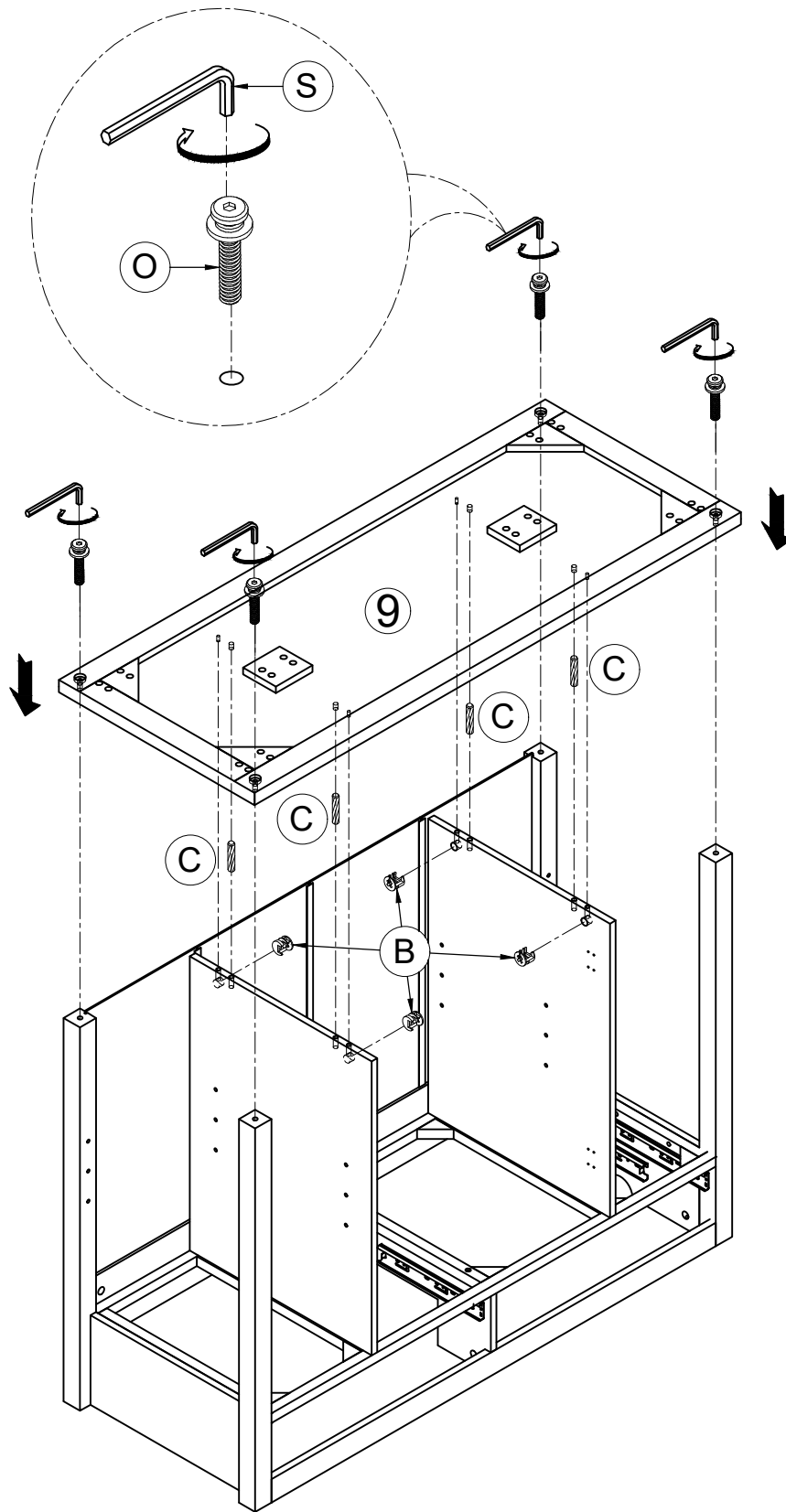

4PCS

ASSEMBLY INSTRUCTIONS

STEP 13





B		4PCS
C		4PCS
O		4PCS
S		1PC

ASSEMBLY INSTRUCTIONS

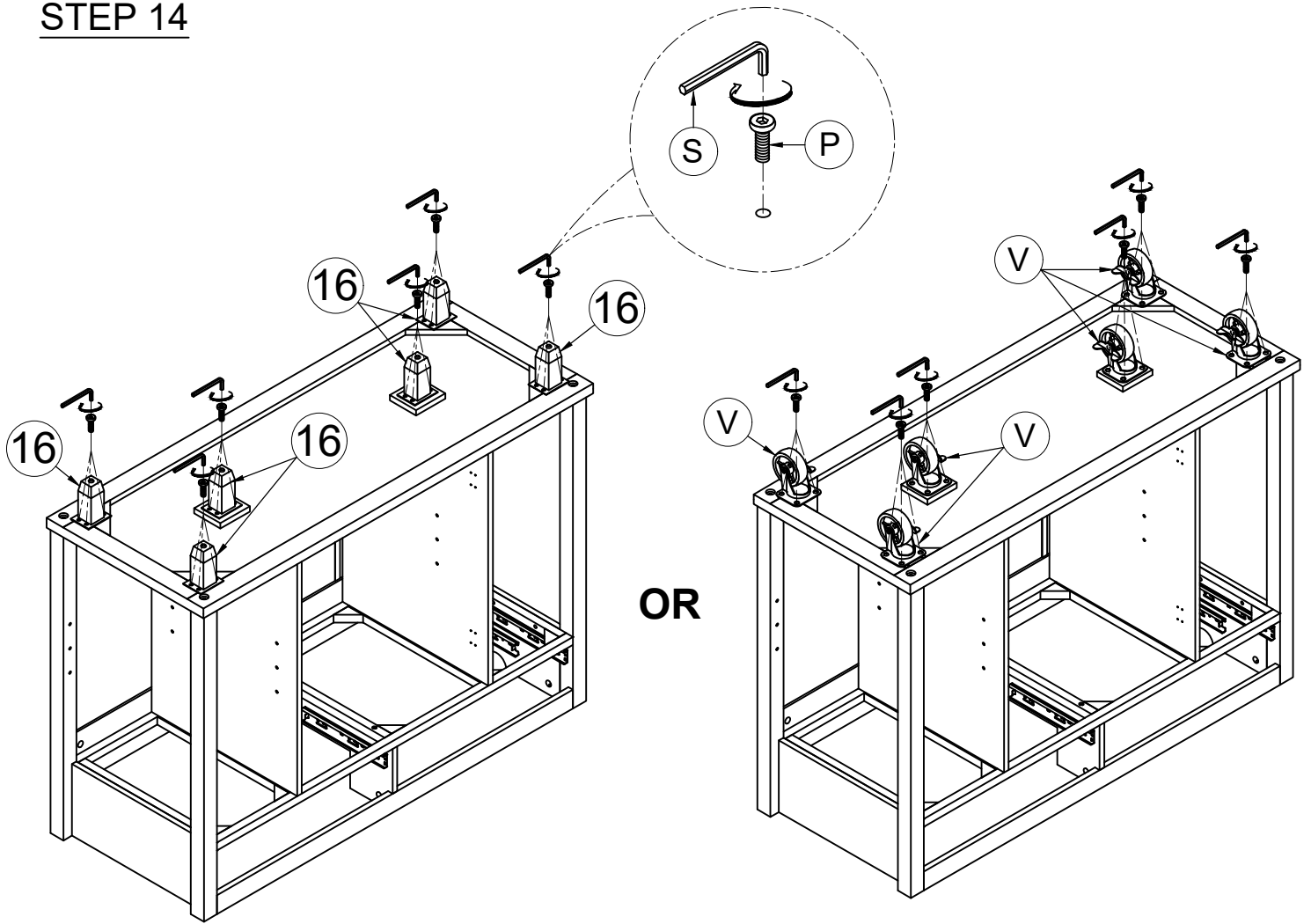
STEP 14





OR

P		24PCS	S		1PC	V		6PCS
---	---	-------	---	---	-----	---	---	------

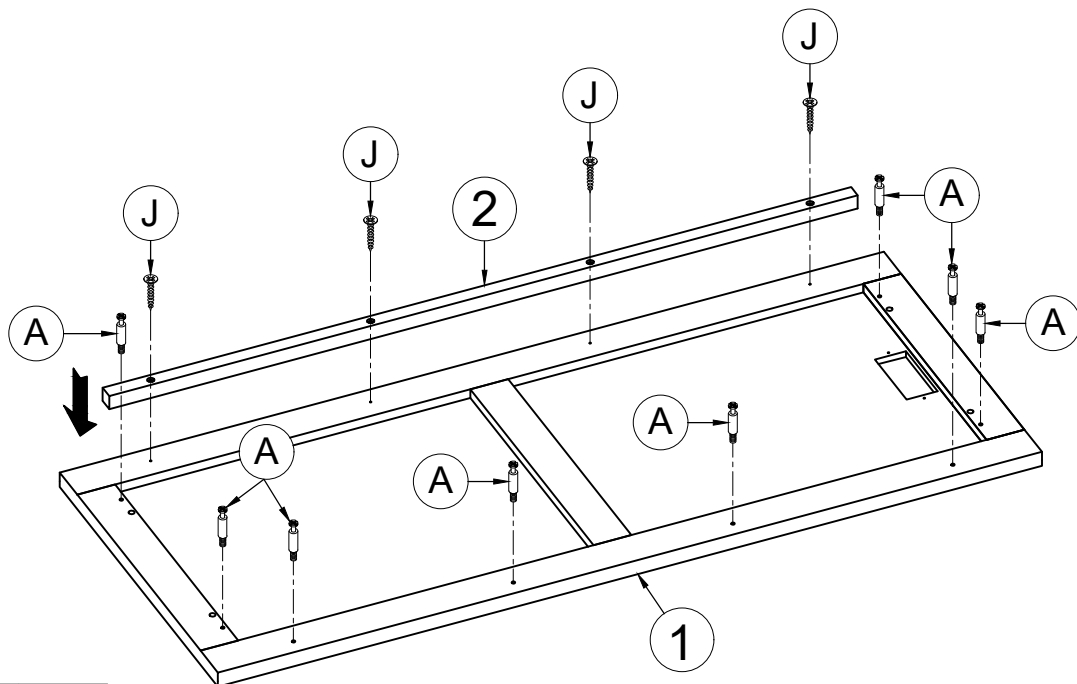
STEP 15

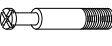



A		8PCS
J		4PCS

ASSEMBLY INSTRUCTIONS

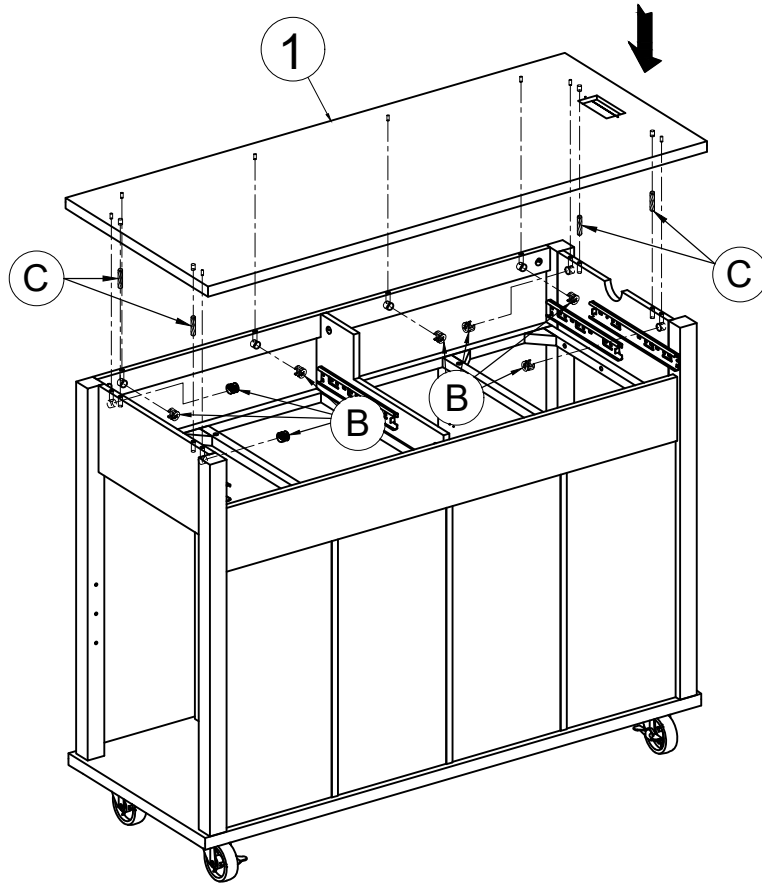
STEP 16



B		8PCS
C		4PCS

STEP 17

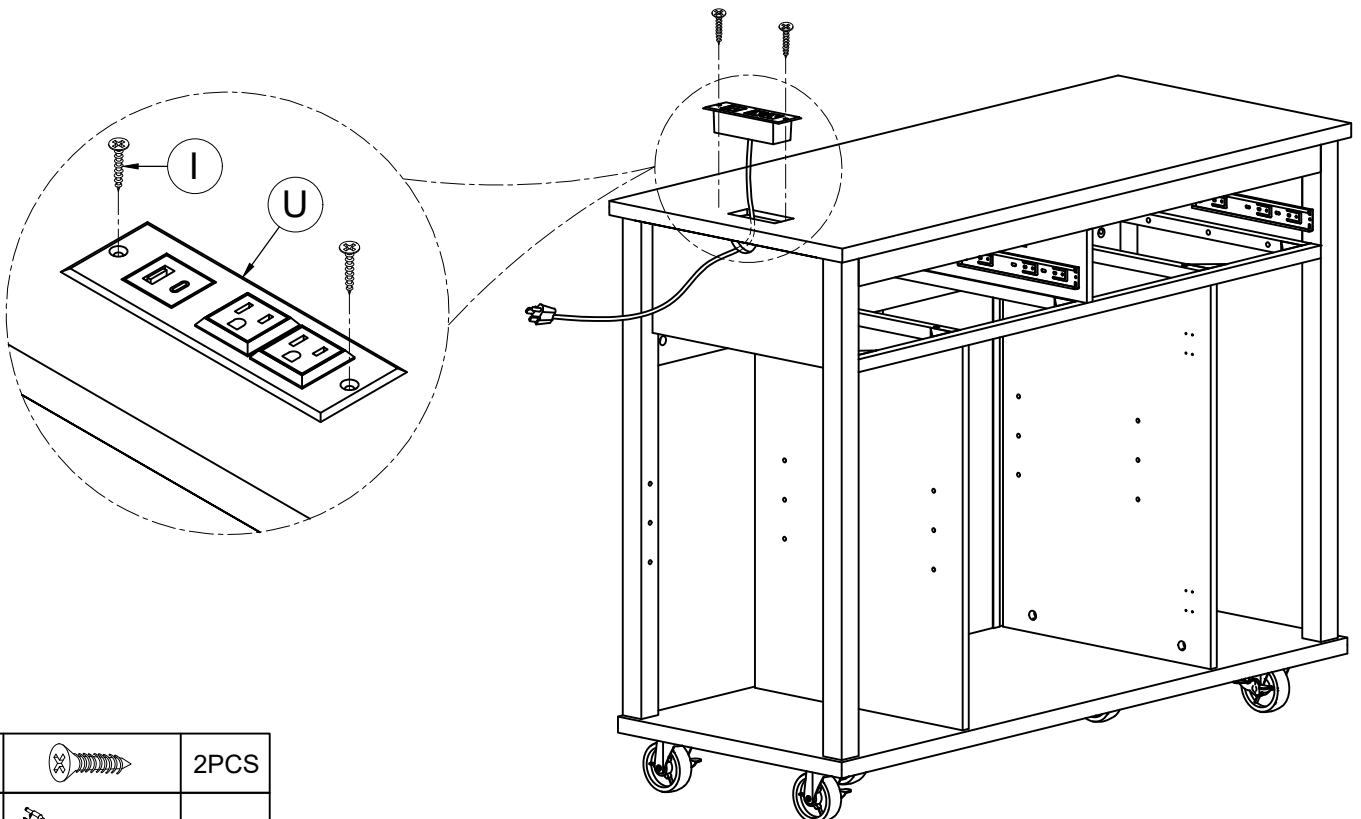

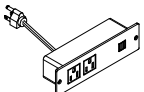
I		2PCS
U		1PC

ASSEMBLY INSTRUCTIONS

STEP 18

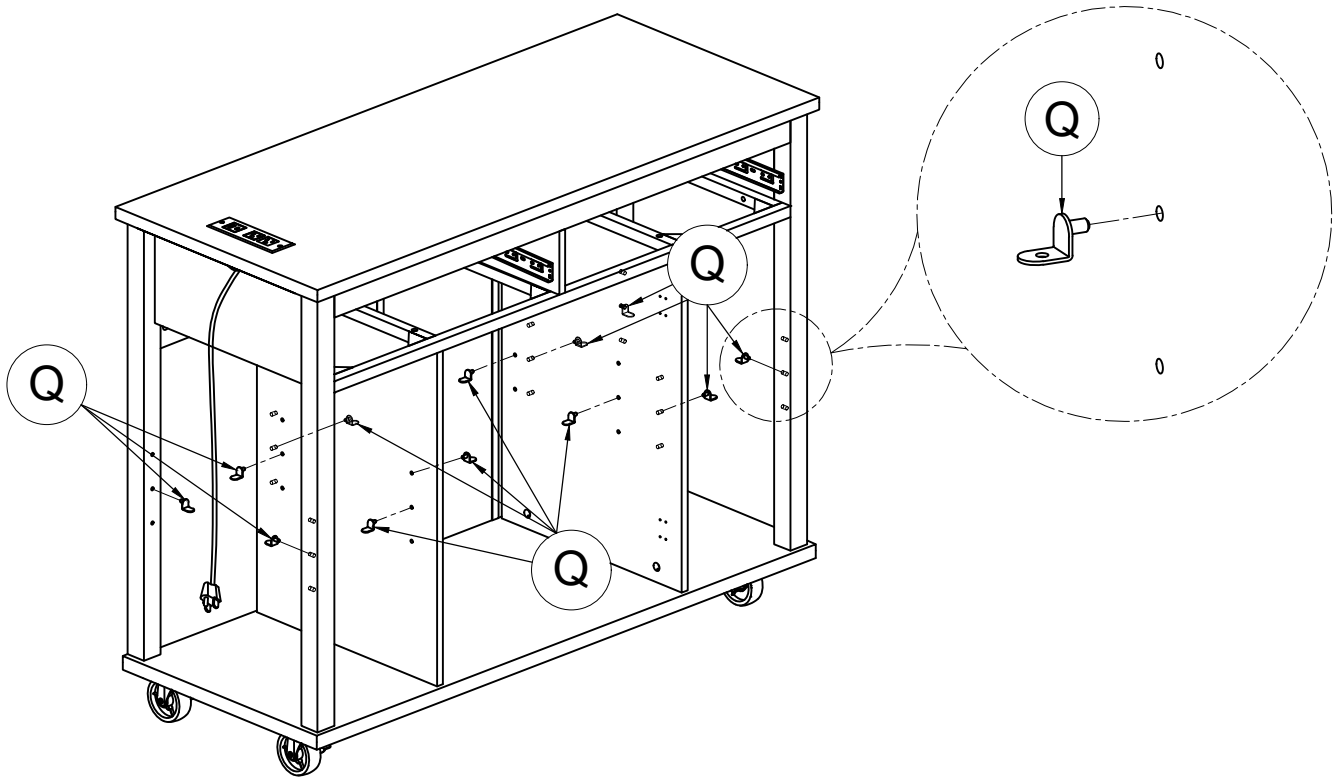

Q		12PCS
---	---	-------

STEP 19

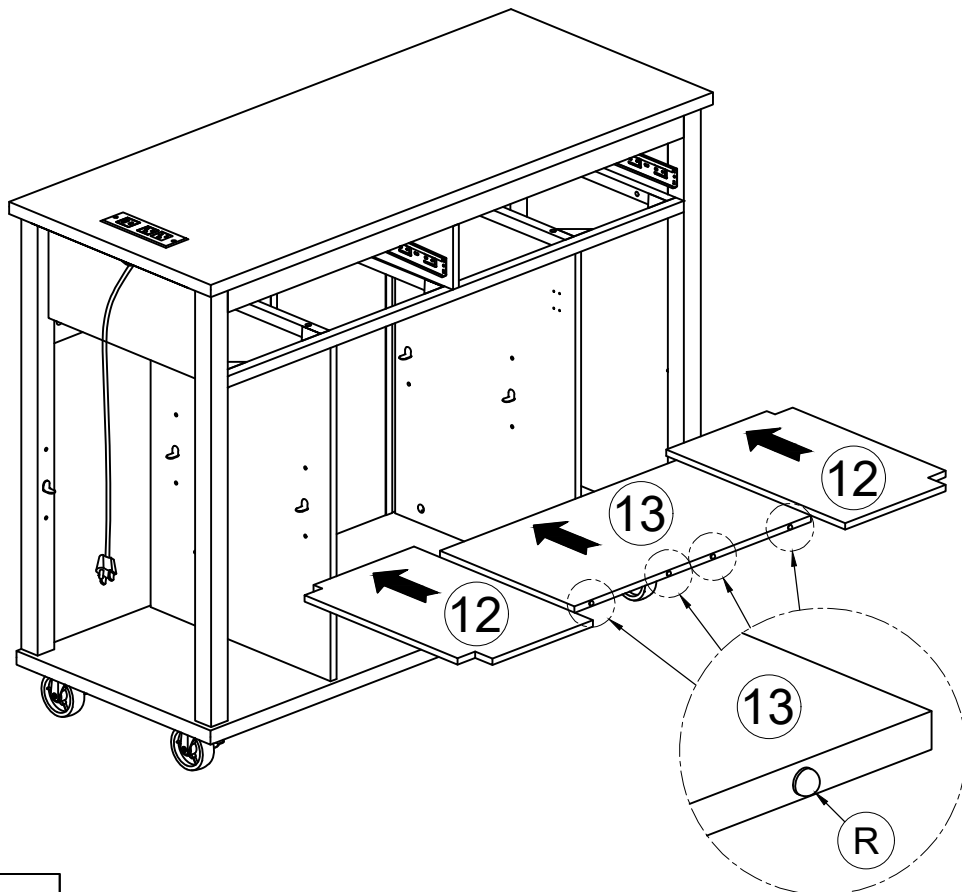

R		4PCS
---	---	------

ASSEMBLY INSTRUCTIONS



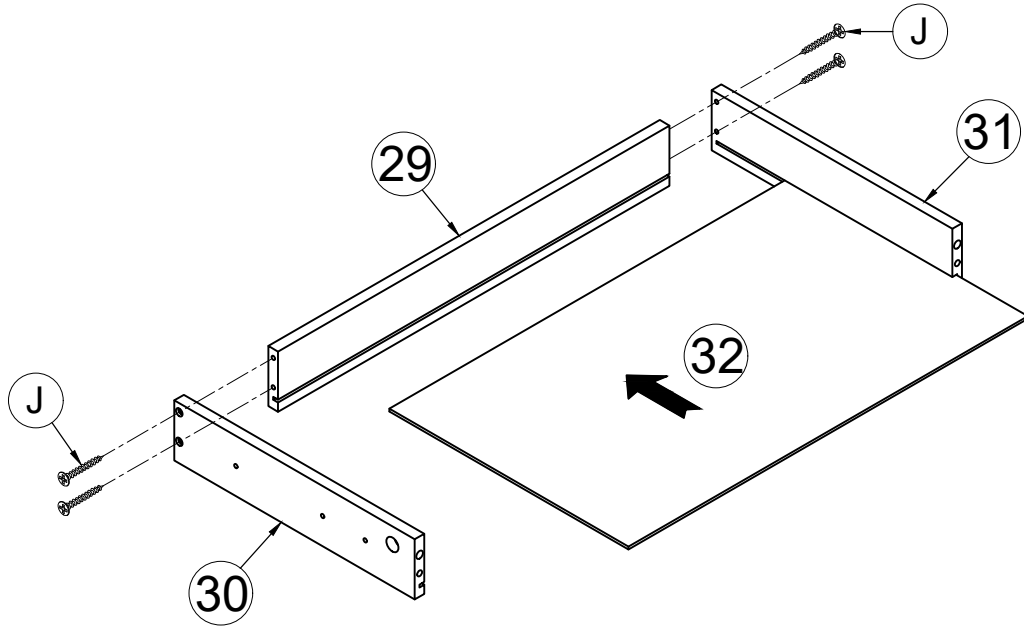

STEP 20 x2 Set

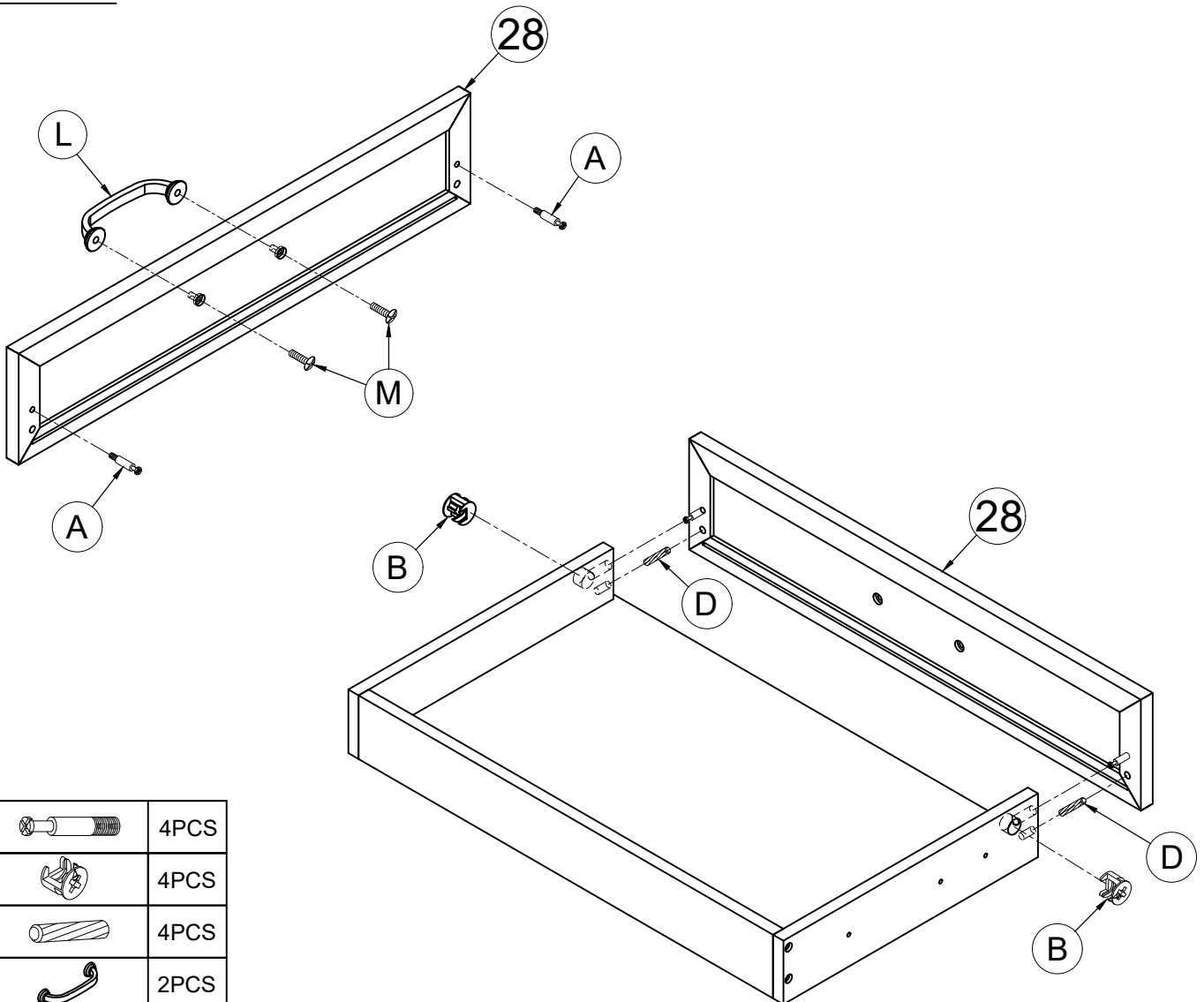

J		8PCS
---	---	------

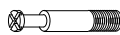
STEP 21 x2 Set





A		4PCS
B		4PCS
D		4PCS
L		2PCS
M		4PCS

ASSEMBLY INSTRUCTIONS

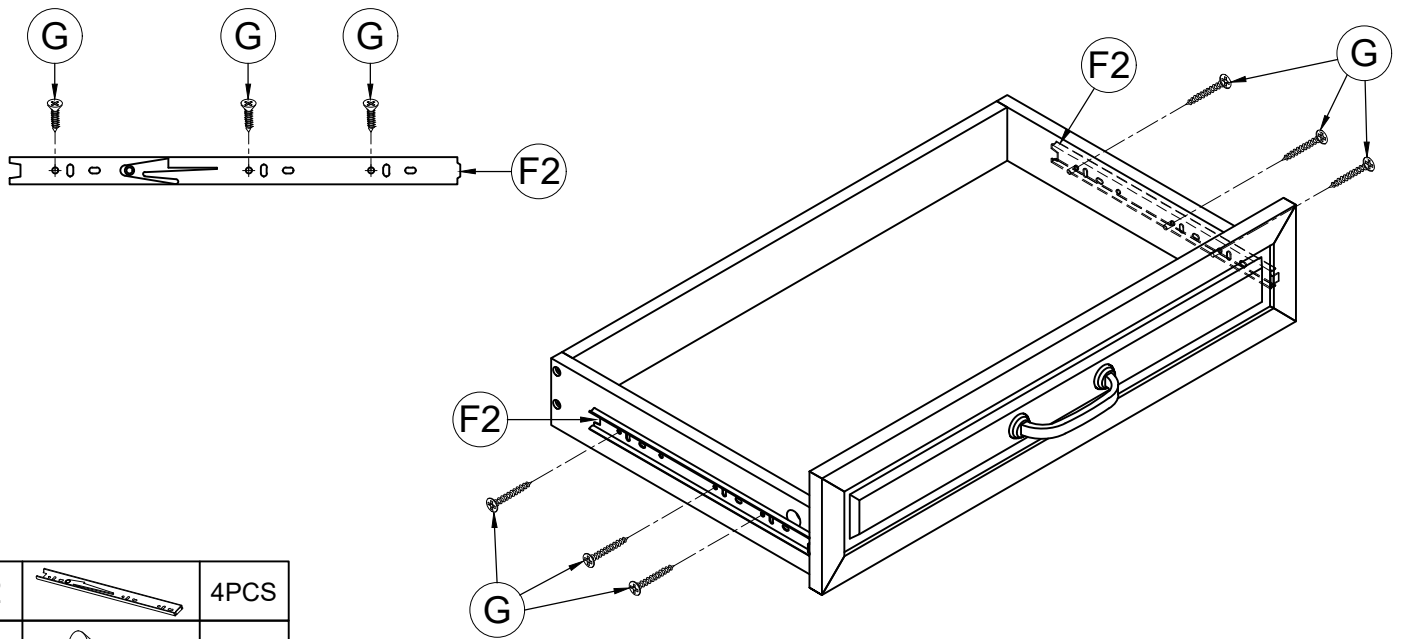

STEP 22 x2 Set

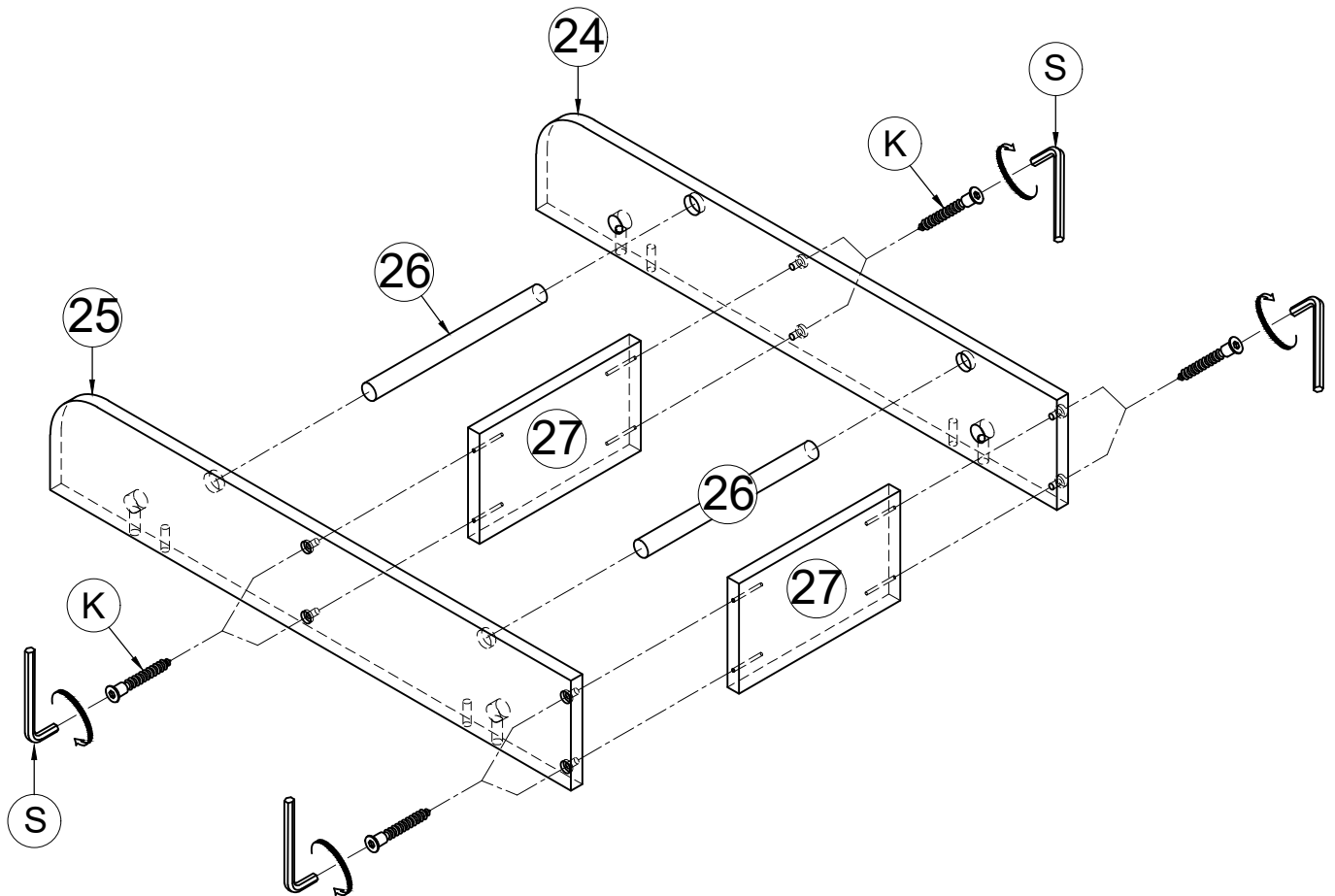

F2		4PCS
G		24PCS

STEP 23 x2 Set



K		16PCS
S		1PC

ASSEMBLY INSTRUCTIONS

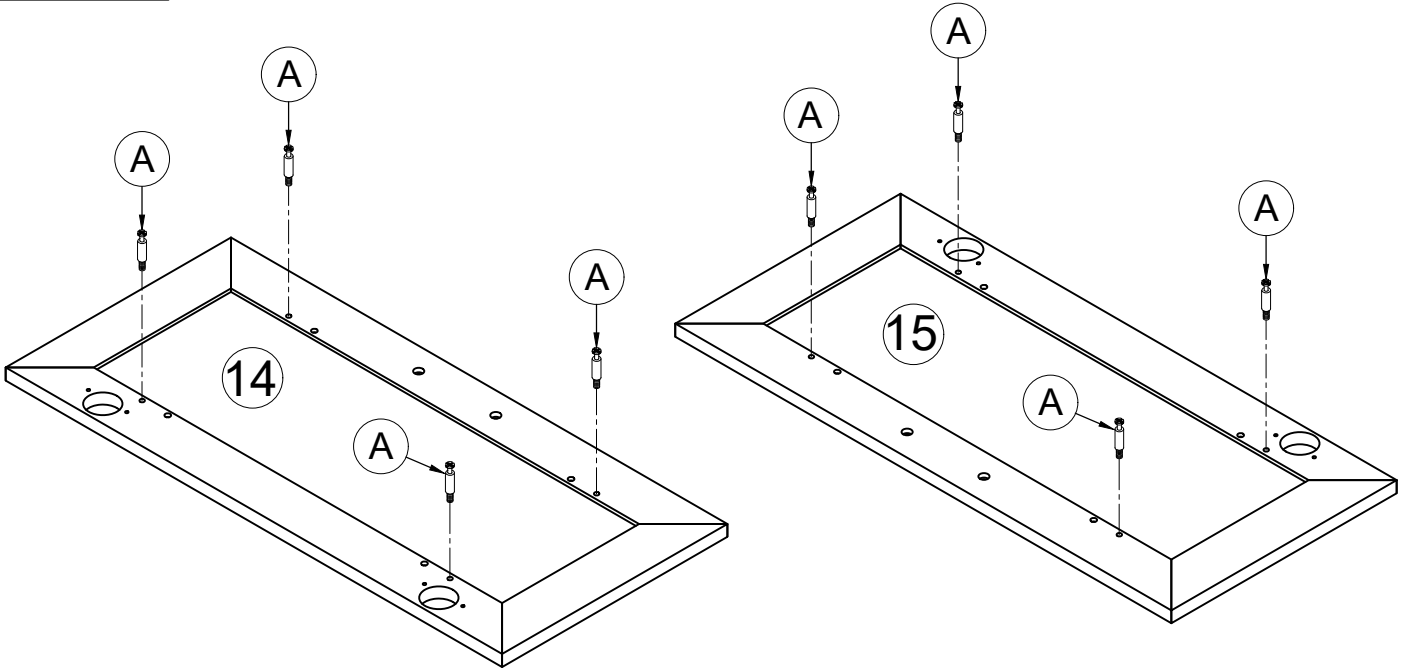

STEP 24

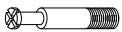

A		8PCS
---	---	------

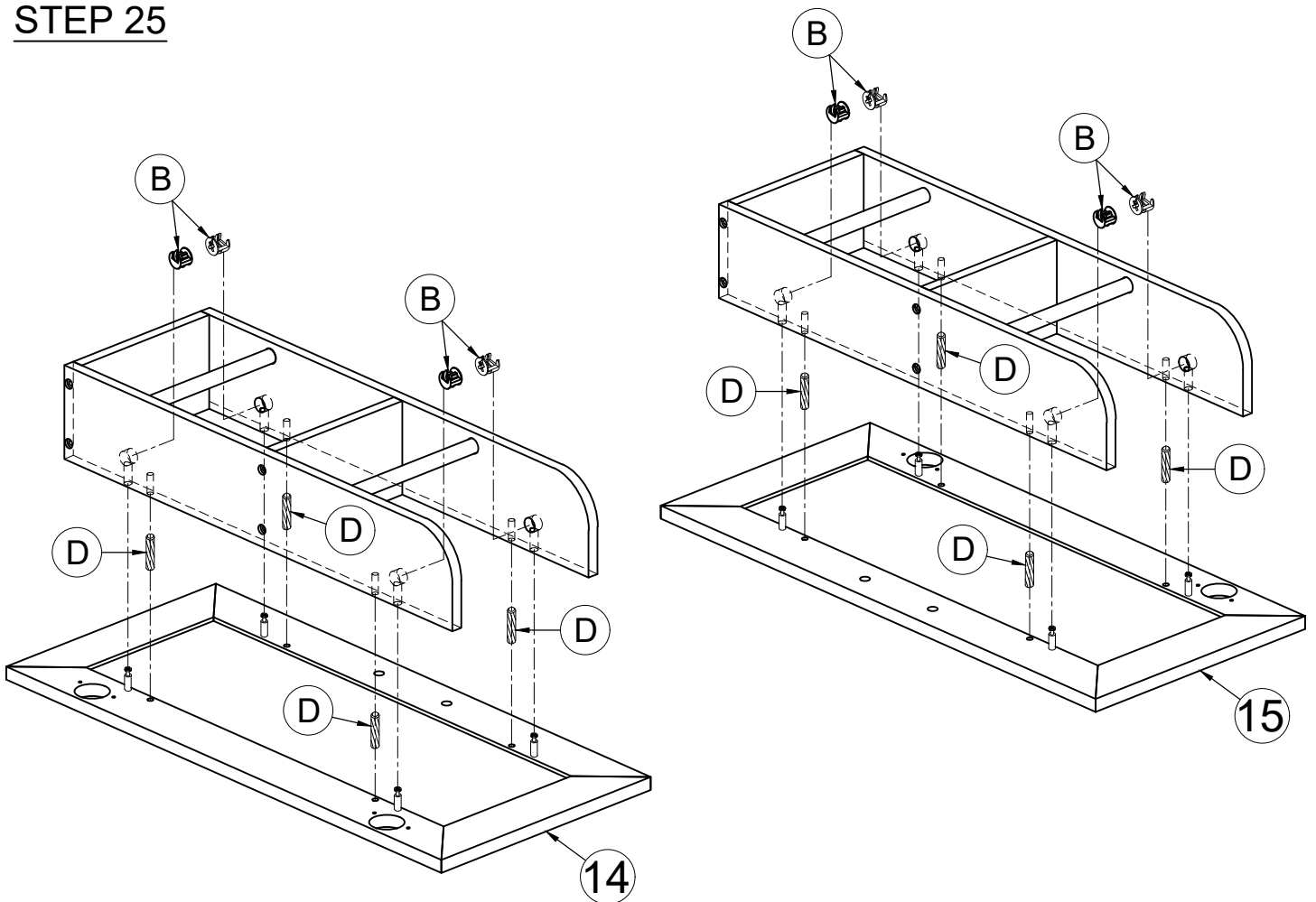
STEP 25





B		8PCS
D		8PCS

ASSEMBLY INSTRUCTIONS

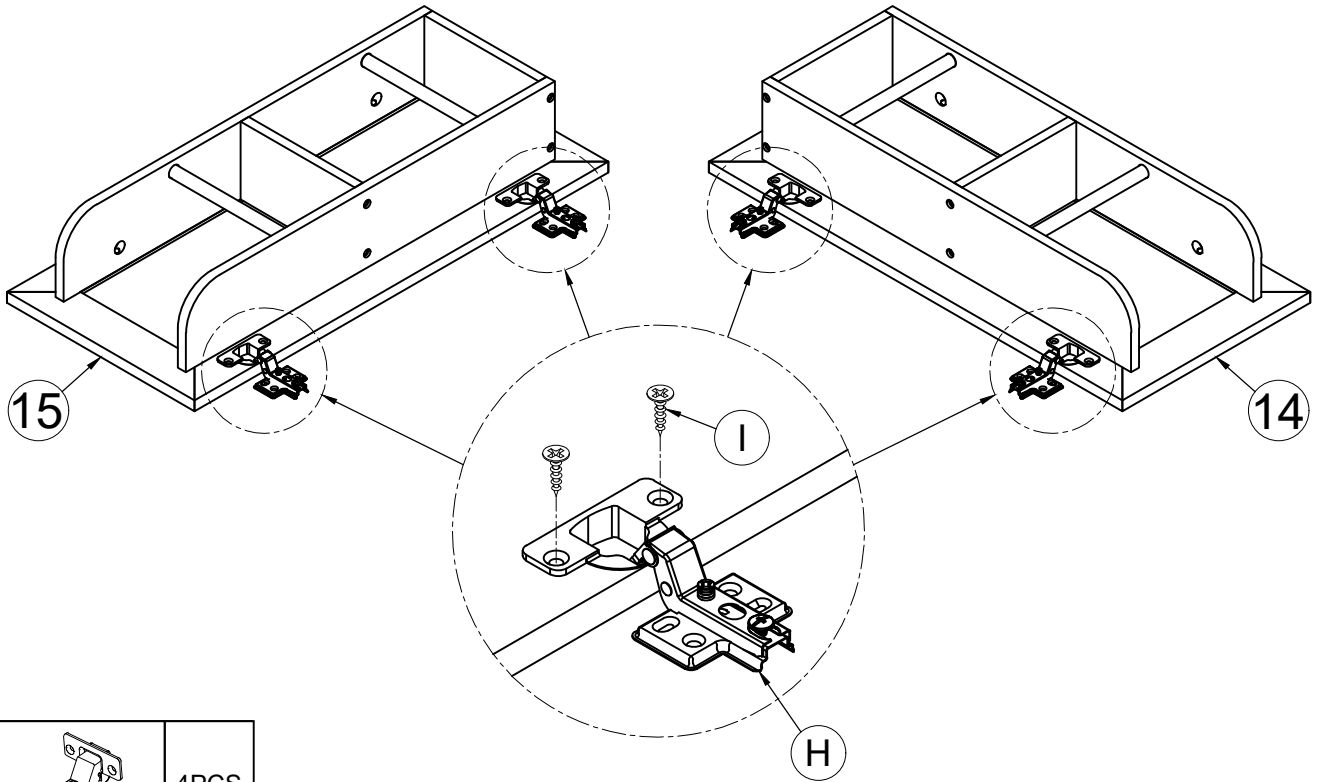

STEP 26

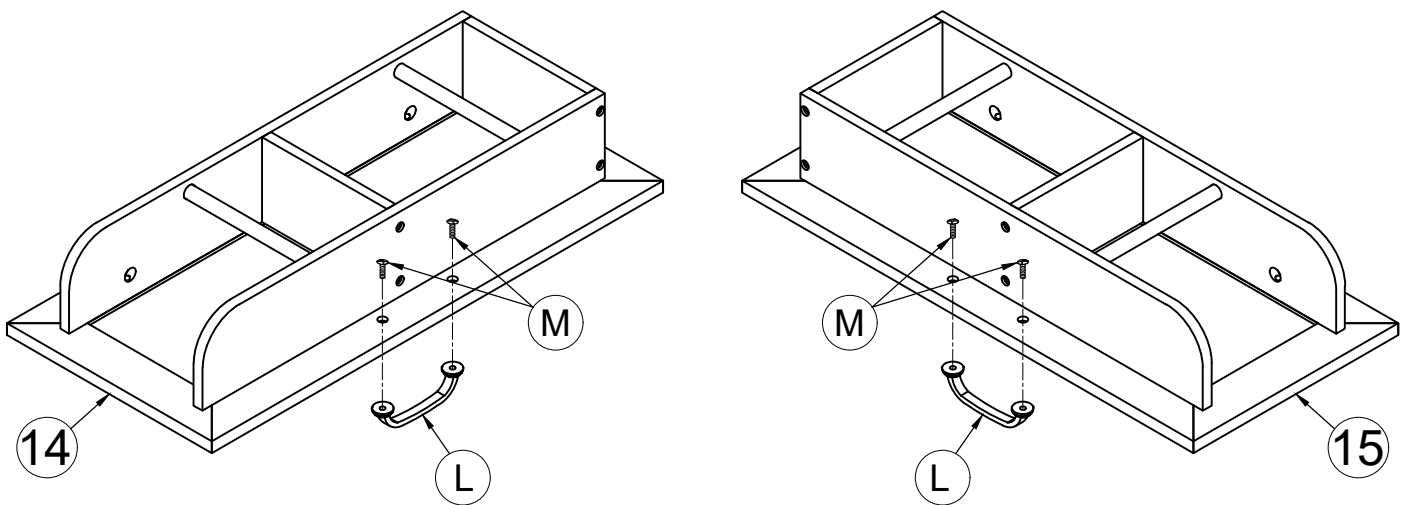

H		4PCS
I		8PCS

STEP 27



L		2PCS
M		4PCS

ASSEMBLY INSTRUCTIONS

STEP 28

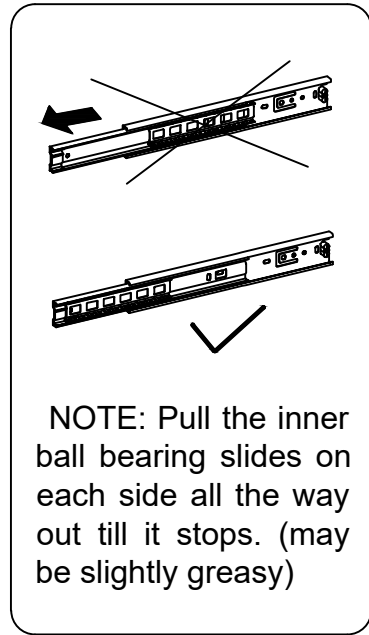
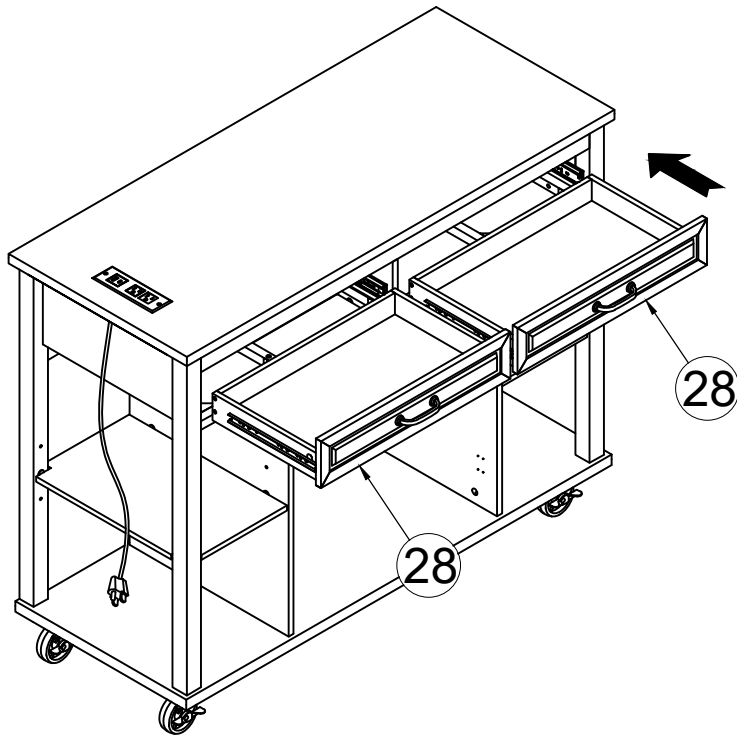

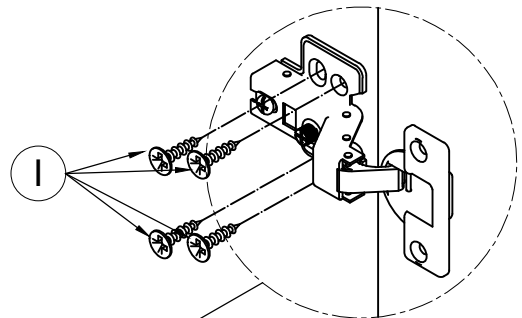
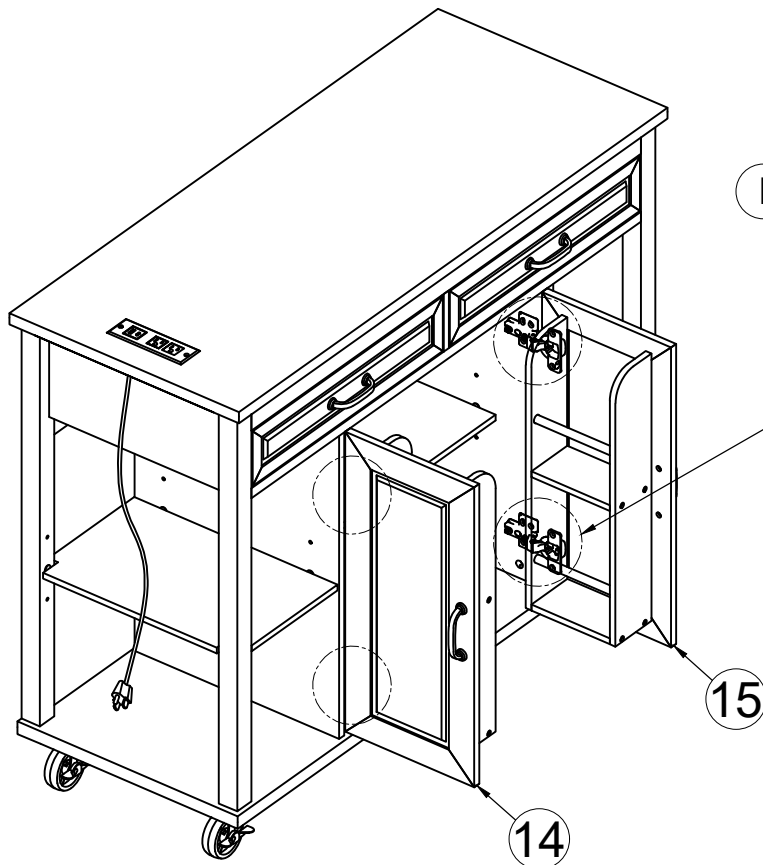

STEP 29



ASSEMBLY INSTRUCTIONS

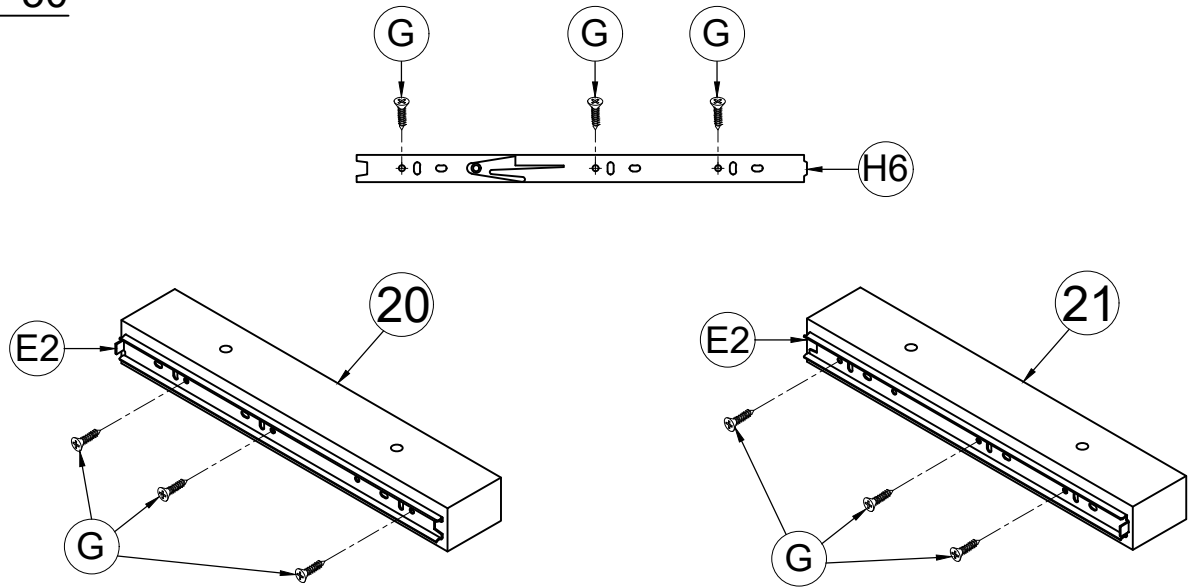

STEP 30

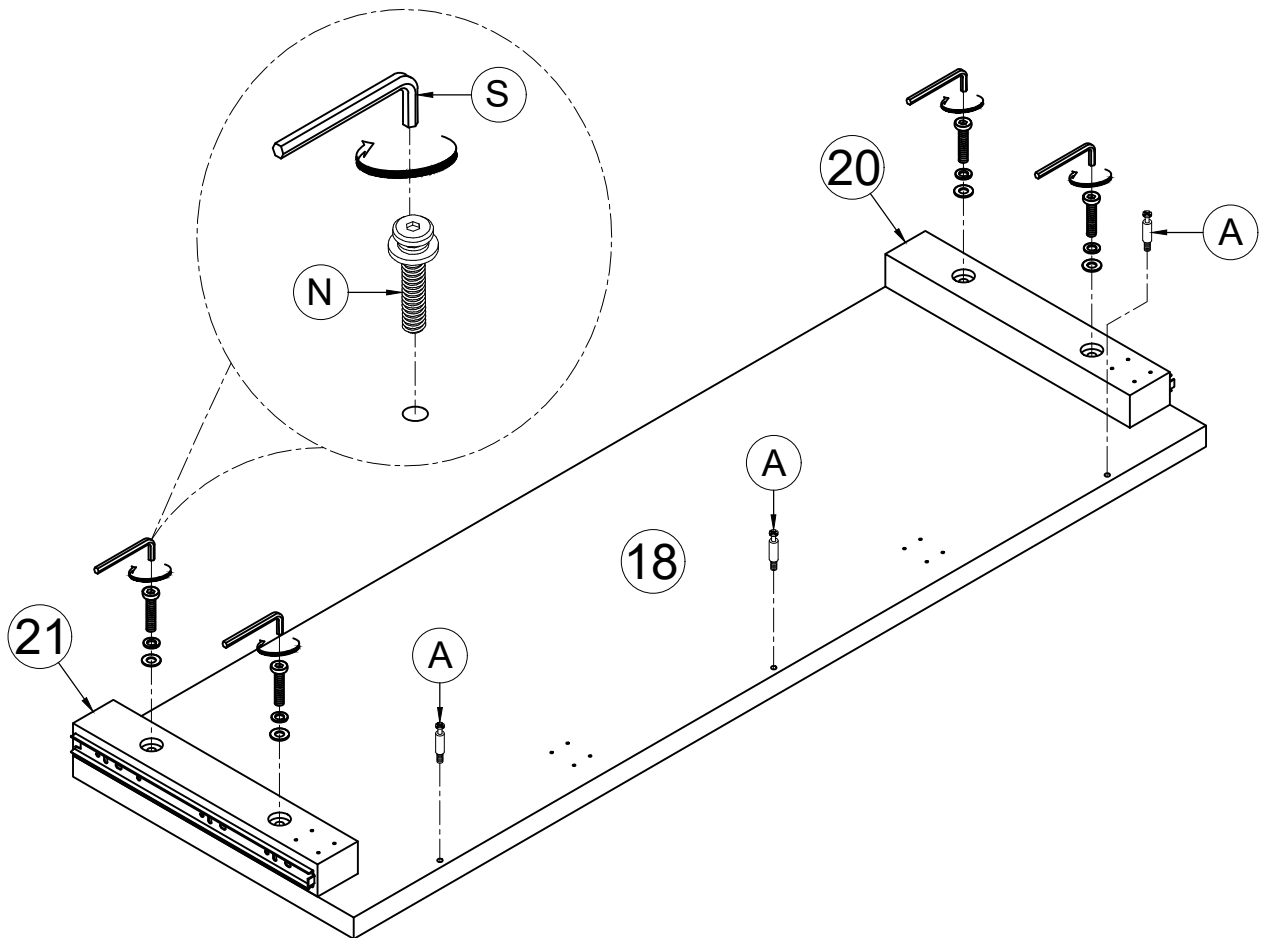

E2		2PCS
G		12PCS

STEP 31

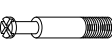
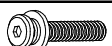

A		3PCS
N		4PCS
S		1PC

ASSEMBLY INSTRUCTIONS

STEP 32

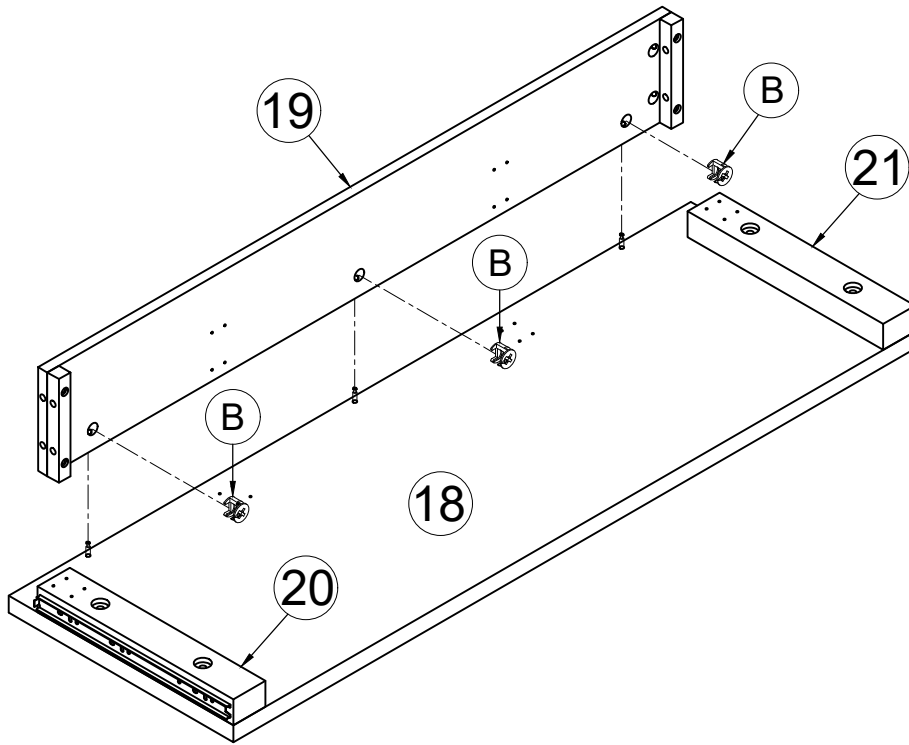

B



3PCS

STEP 33

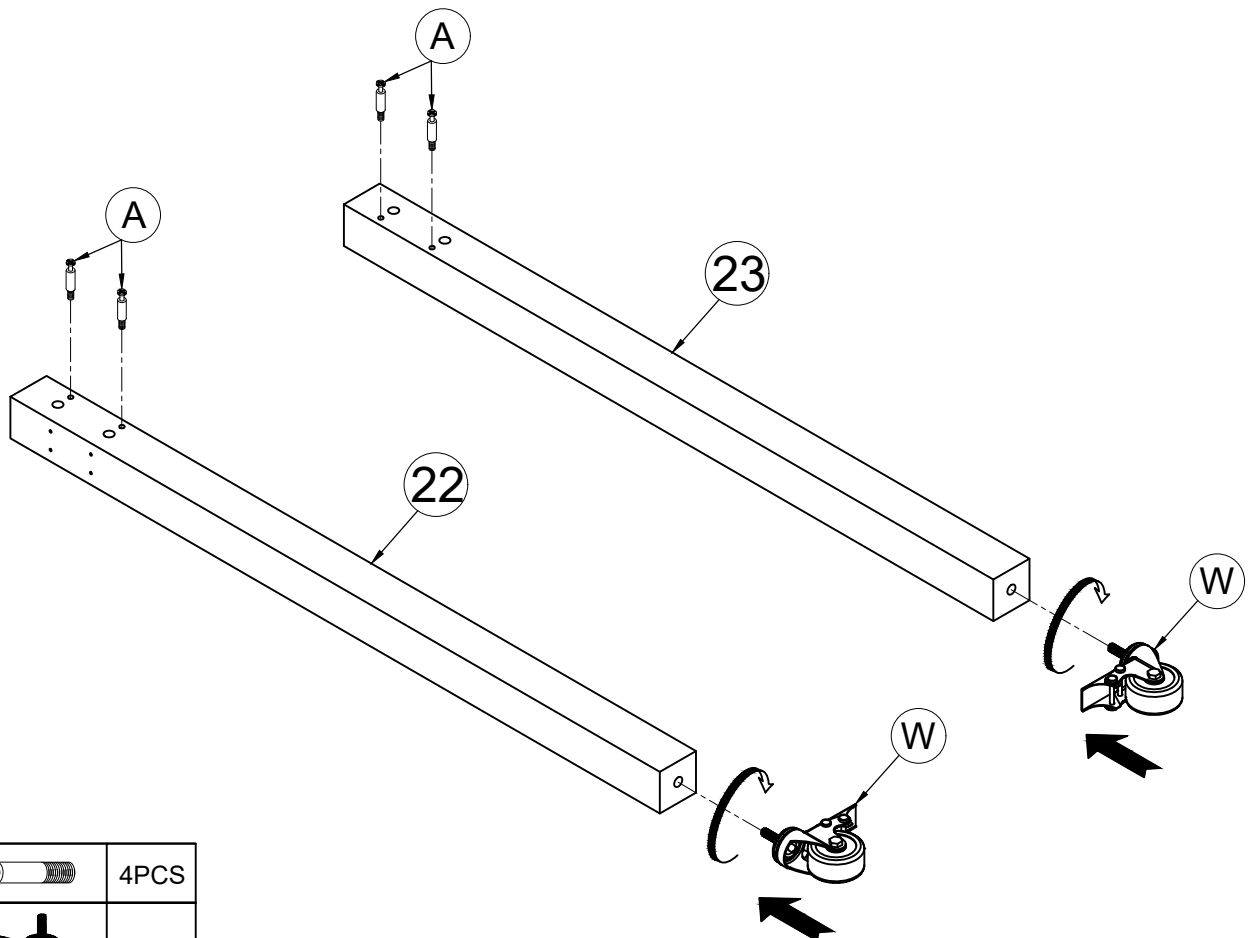

A

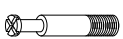

4PCS

W





2PCS

ASSEMBLY INSTRUCTIONS

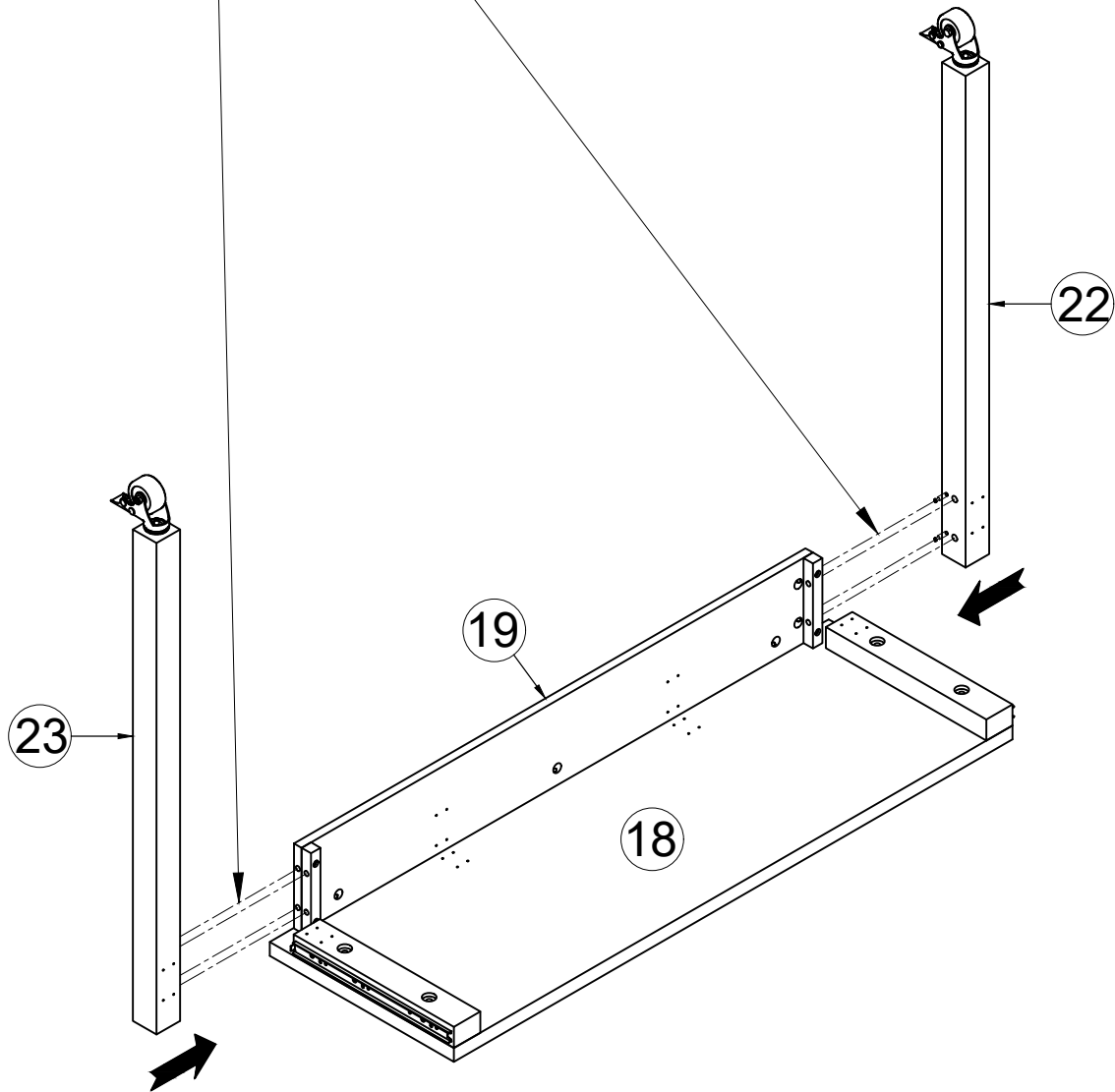
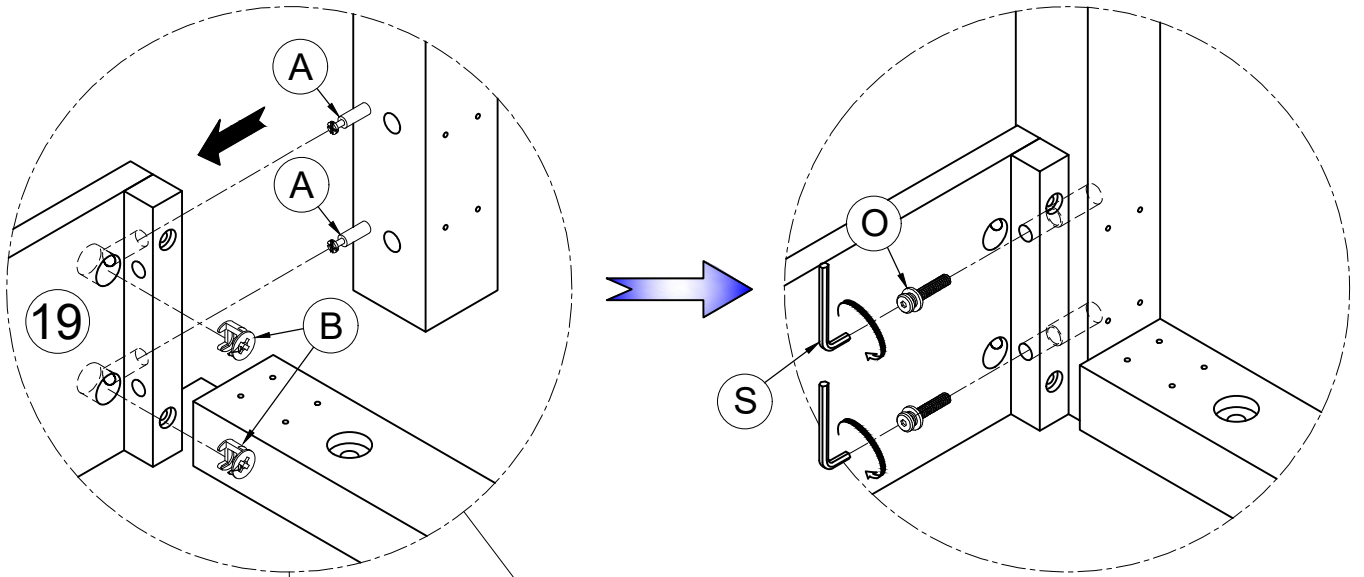
STEP 34





B		4PCS
O		4PCS
S		1PC

ASSEMBLY INSTRUCTIONS

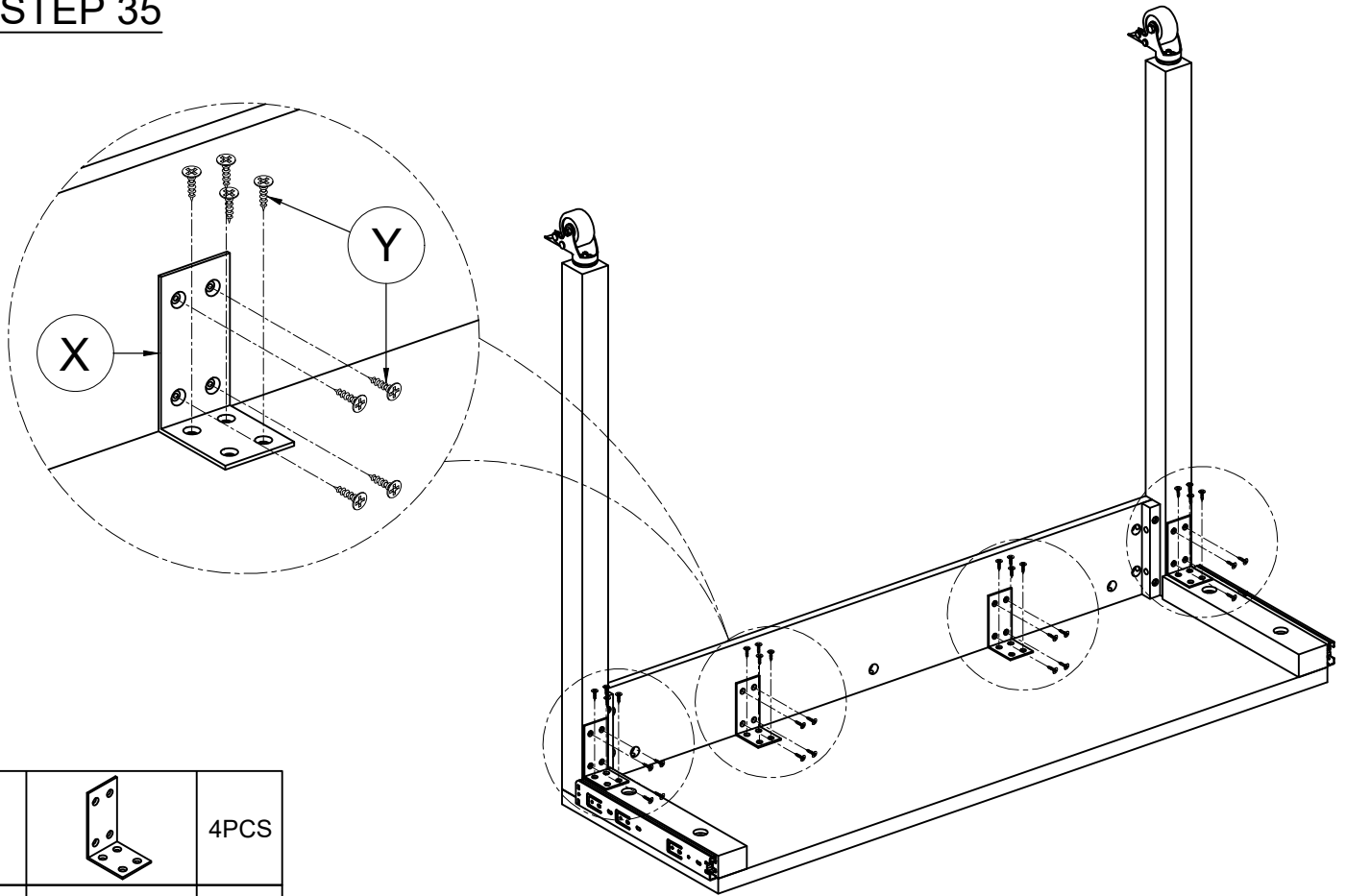
STEP 35



X		4PCS
Y		32PCS

STEP 36

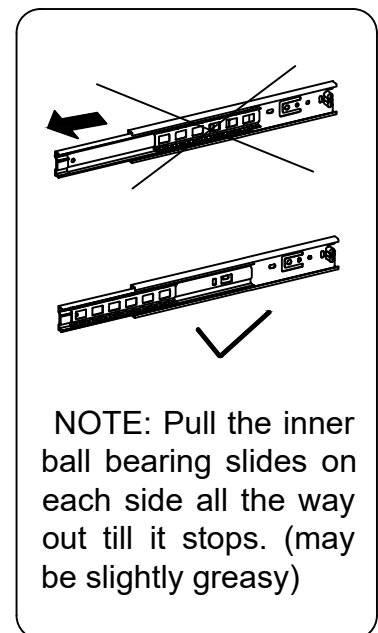
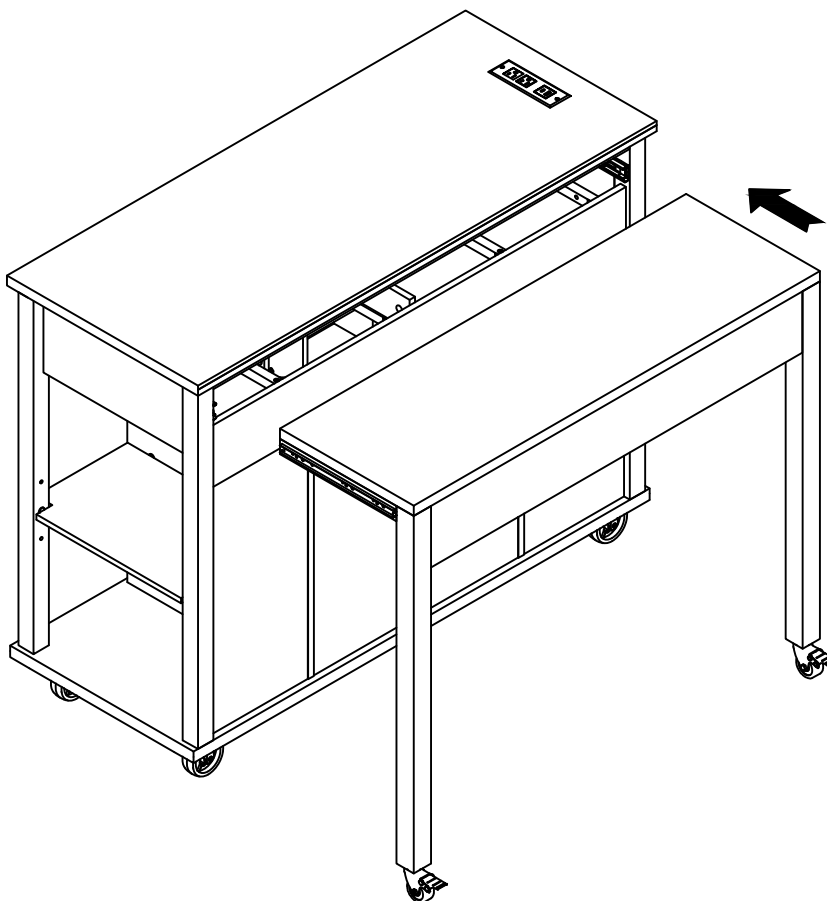

ASSEMBLY INSTRUCTIONS

COMPLETED !

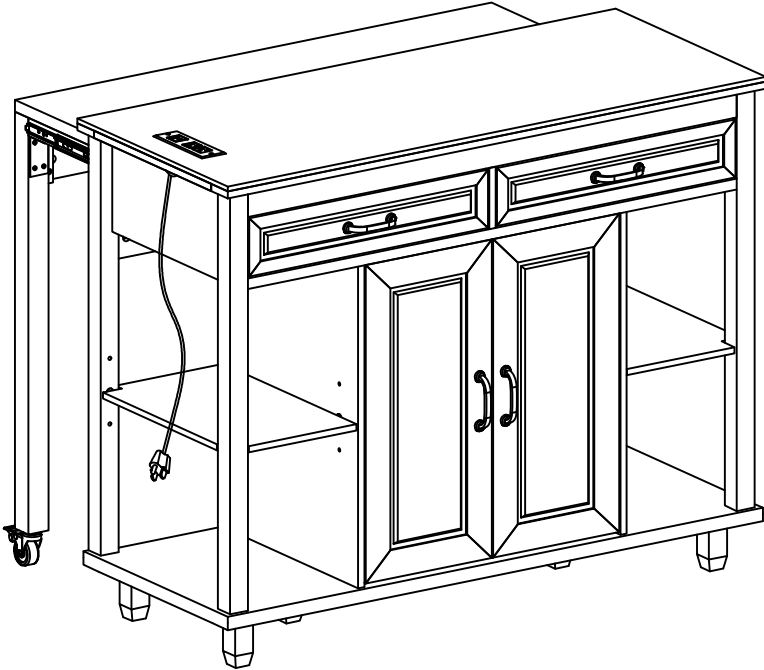

OPTION WITH THE FEETS

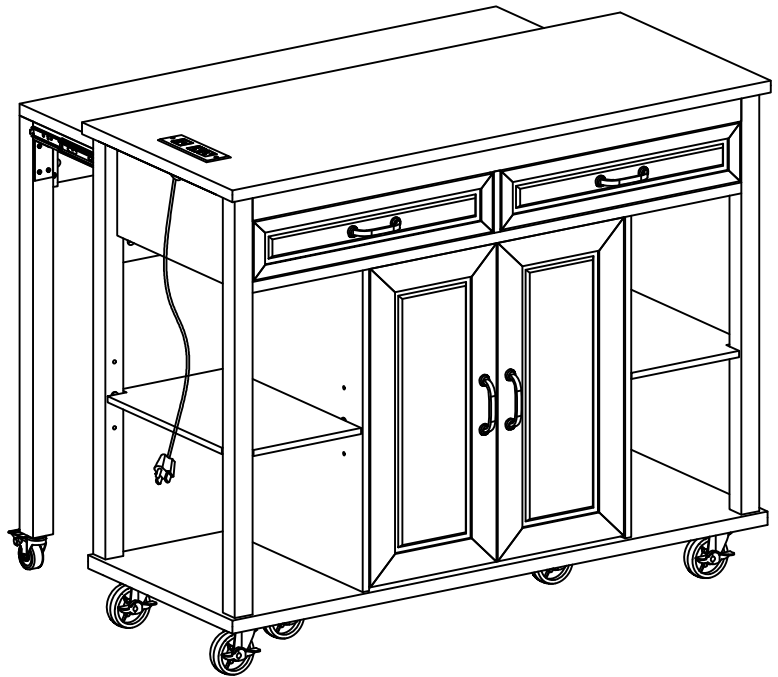

OPTION WITH THE WHEELS