

# Lounge Chair

---

If you have any questions about the Lounge Chair, Please feel free to contact us.

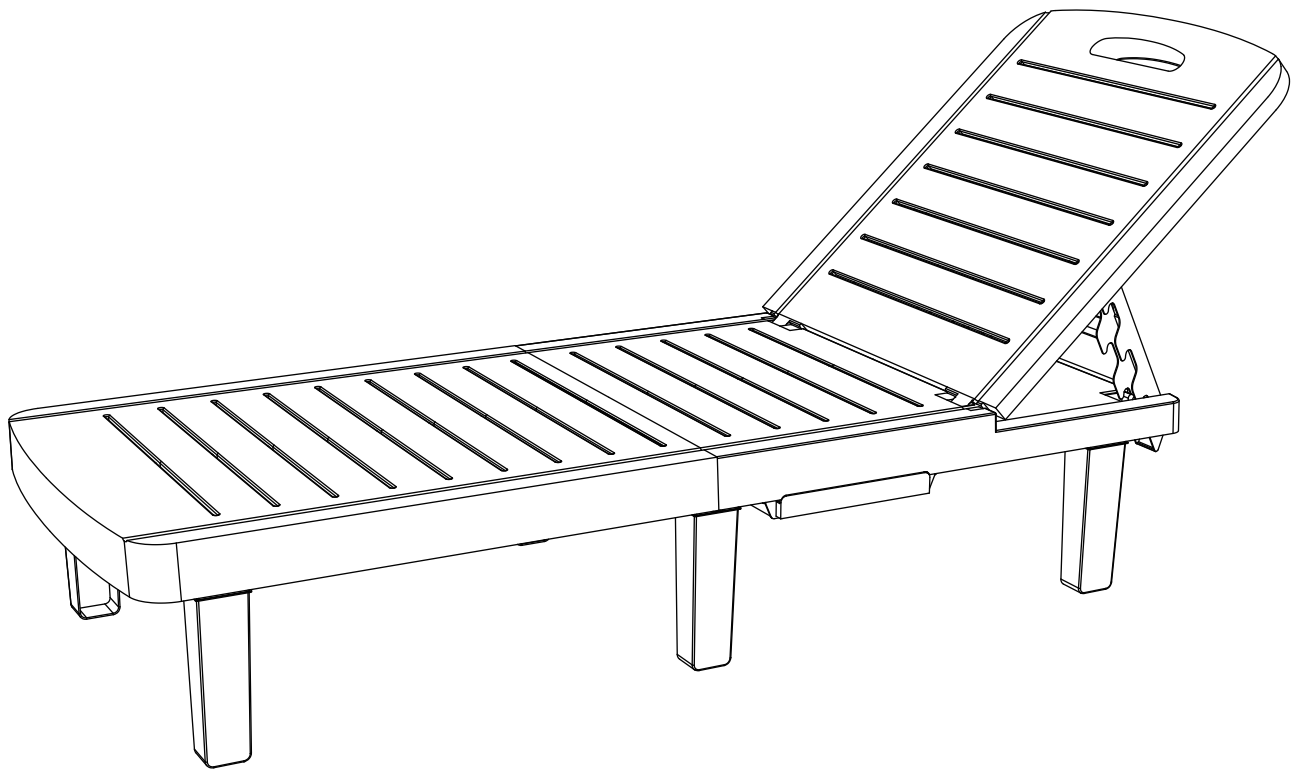

## NOTICE

**Please retain these instructions for future reference.**

### Dear Customer

Thank you for your purchase.

When you receive the product, please make sure that all the parts are intact.

Then please browse the entire installation manual before assembly.

If problem occur unsatisfactorily as follows

- A** . The outer box is damaged
- B** . The product is damaged / bent / cracked while you open the box
- C** . The parts / accessories / assembly tools are missing
- D** . The product is hard to assemble
- E** . The instructions are not clear and can not be referred
- F** . The product has functional problems
- G** . Other aspects that you are not satisfied with

Please do not hesitate to contact us for help. Our team with factory direct after-sales service will reply within 24 hours and will do our best to resolve the problem for you.

## HARDWARE

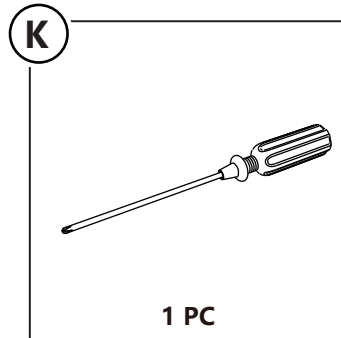
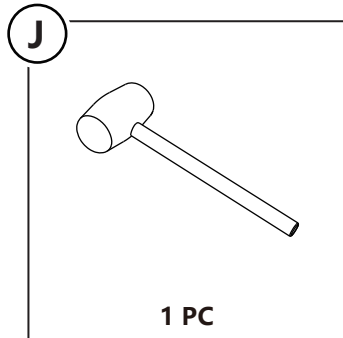
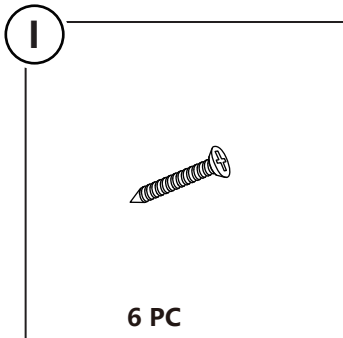

# PARTS

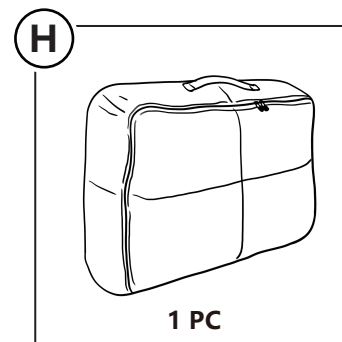
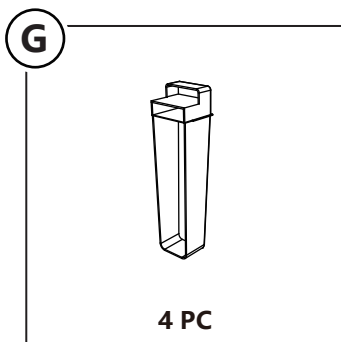
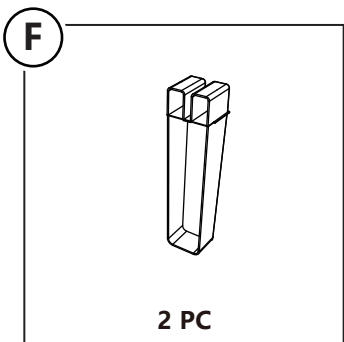
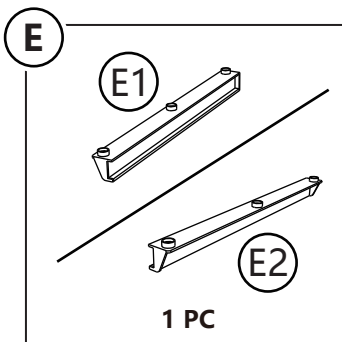
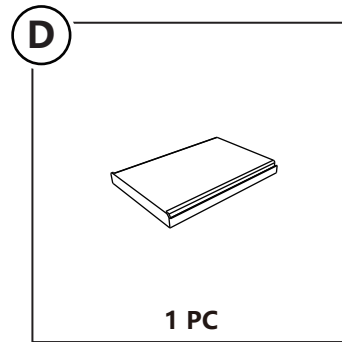
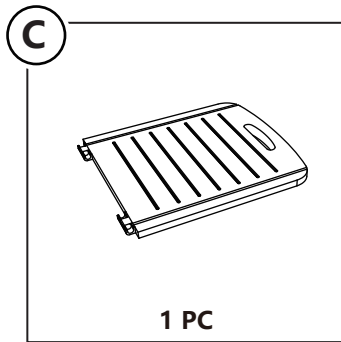
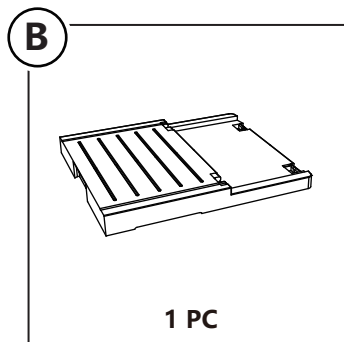
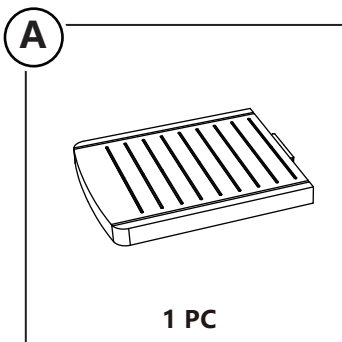

# PRODUCT ASSEMBLY

## Step 1

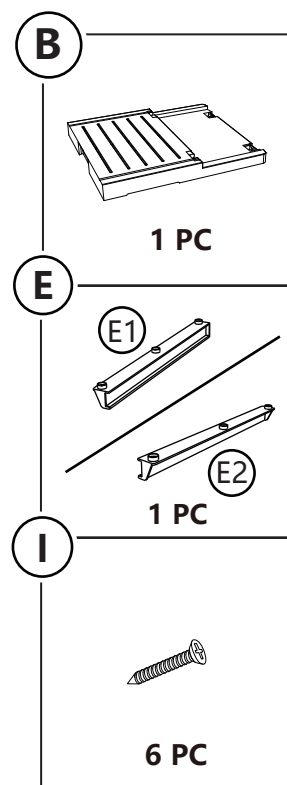
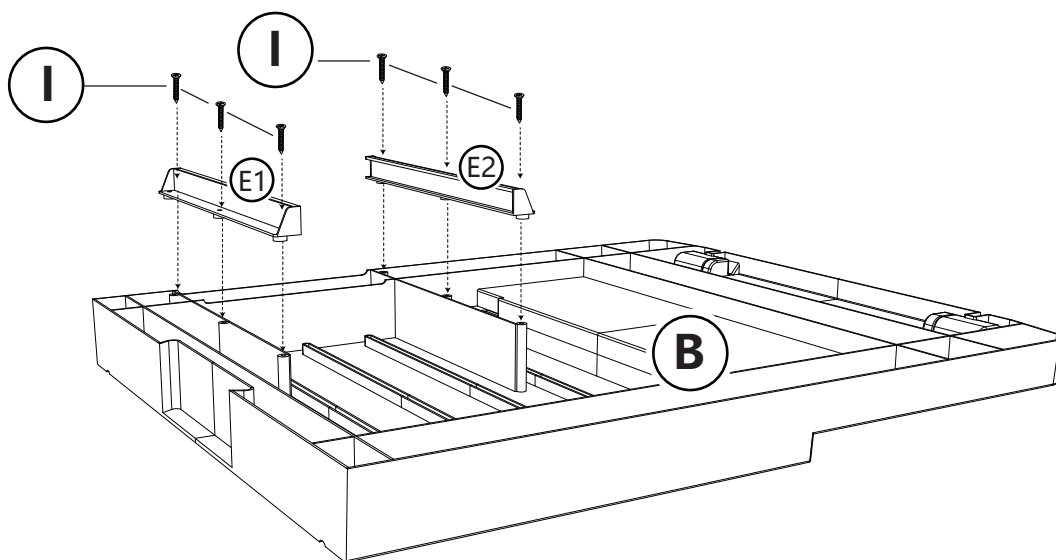

# PRODUCT ASSEMBLY

## Step 2

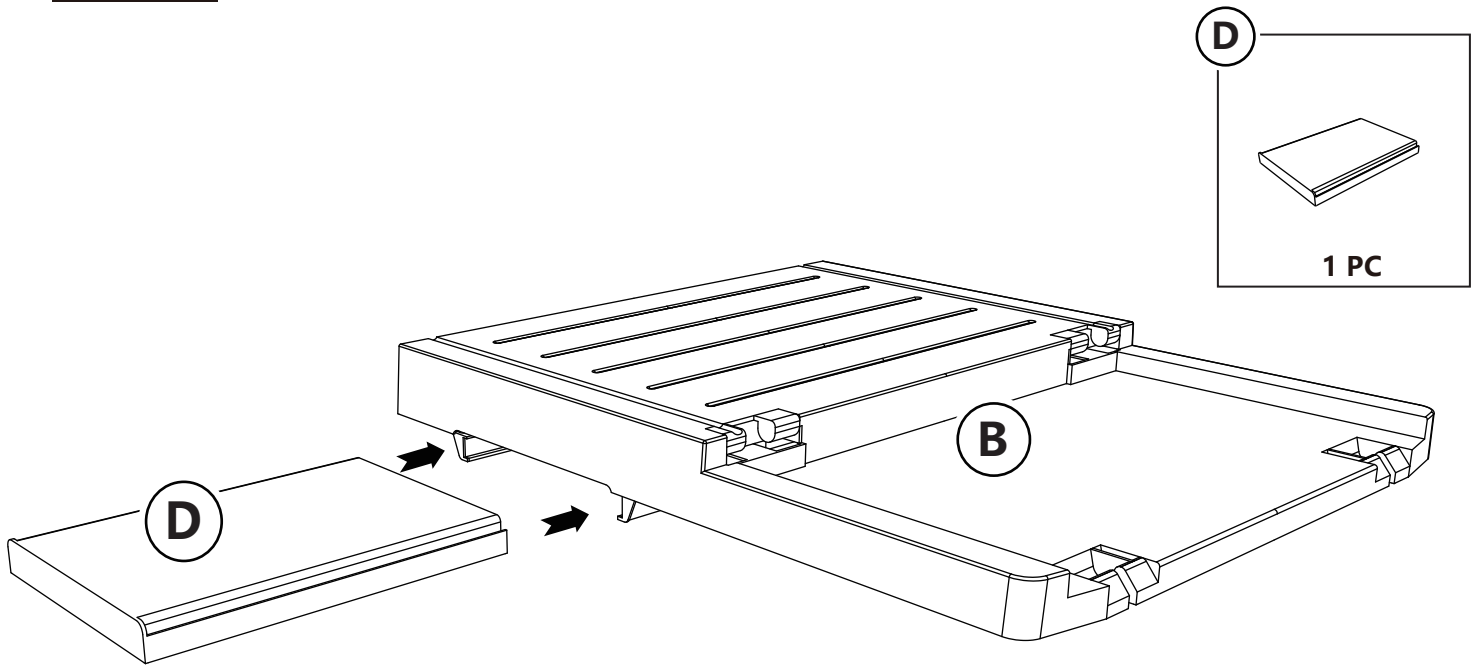

## Step 3

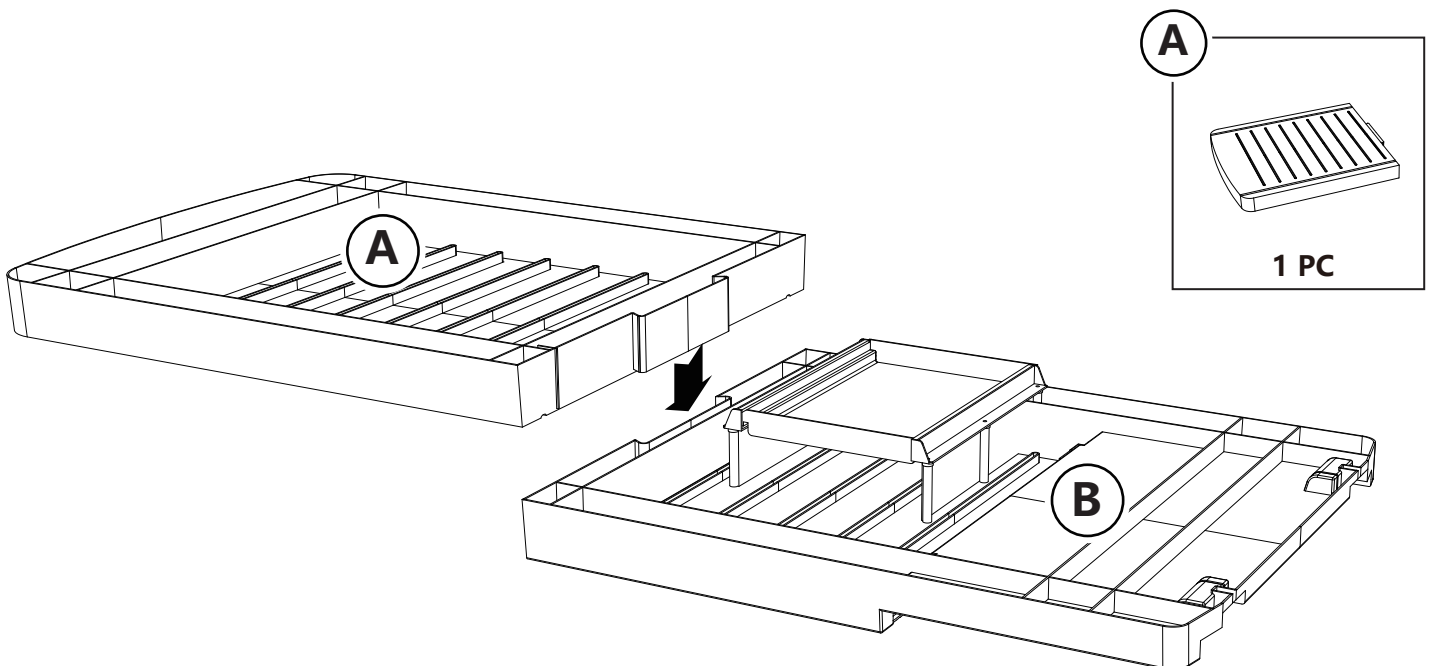

# PRODUCT ASSEMBLY

## Step 4

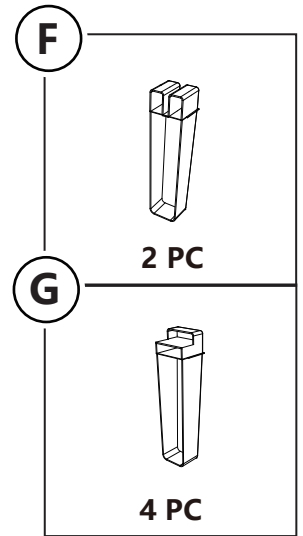
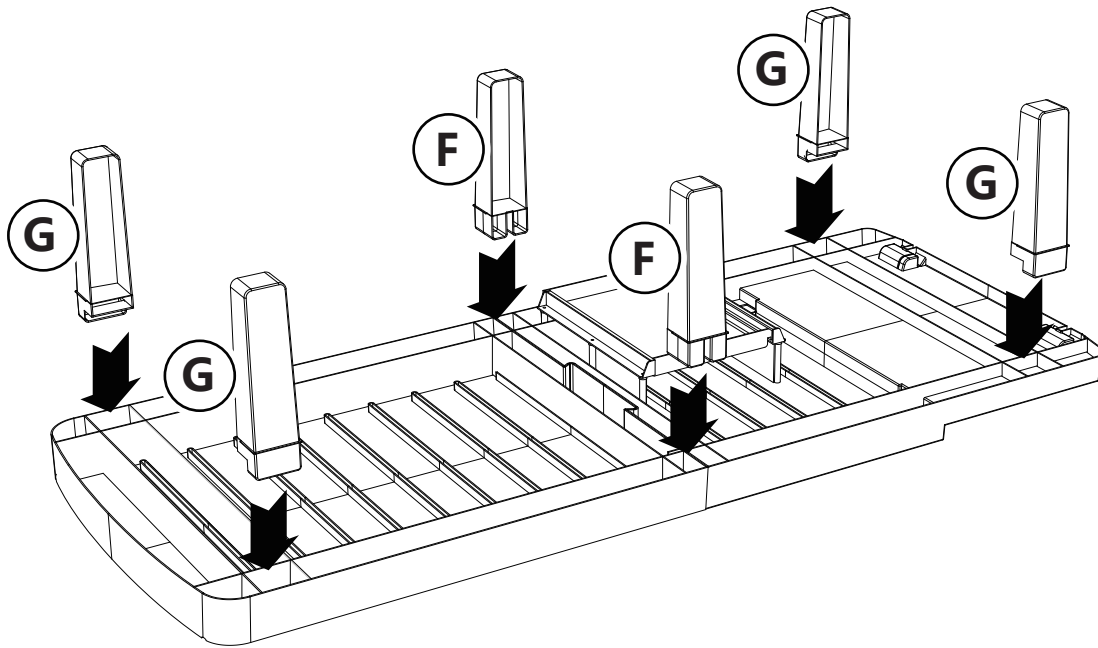

## Step 5

The back plate is vertical 90 degrees, aligned with the slot of the bottom, and moved inward.

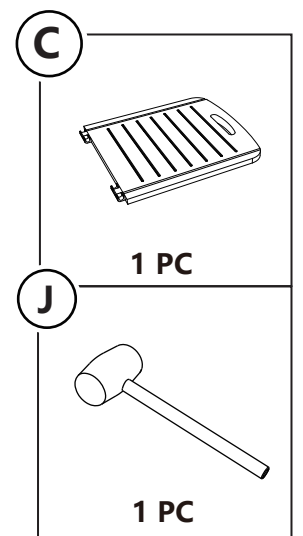
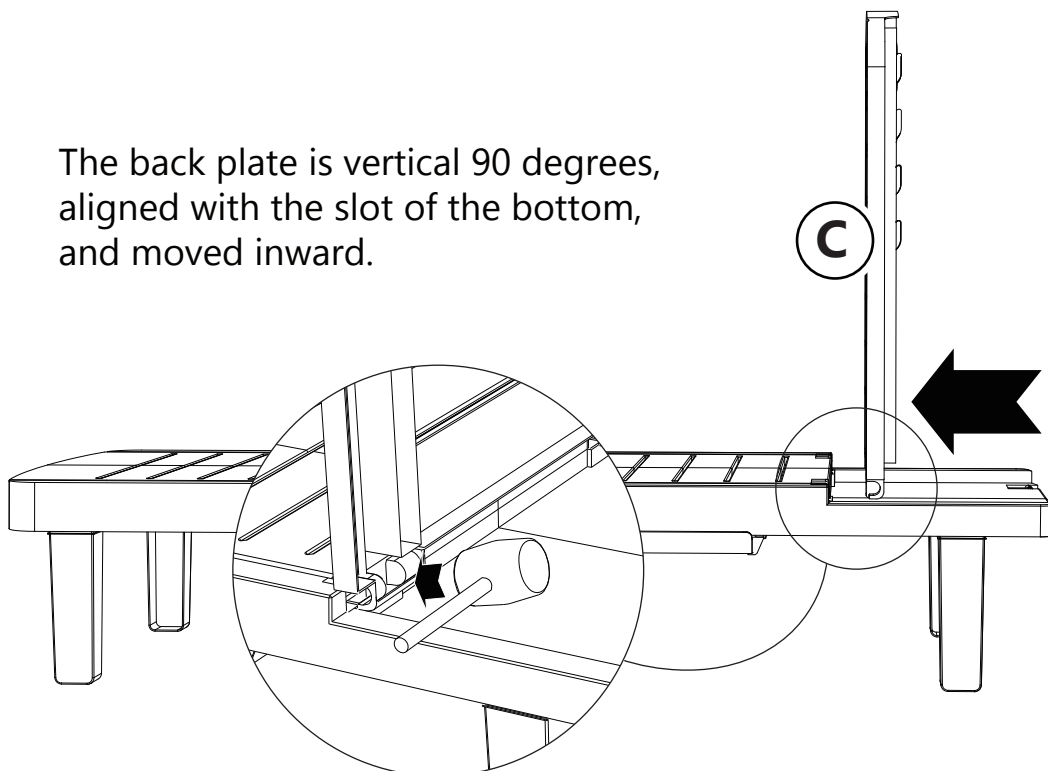

## PRODUCT ASSEMBLY

### Step 6

Rotate the support rod at the back of the backrest, and according to the required angle, buckle the buckle in the slot inside the baseplate to achieve fixation.

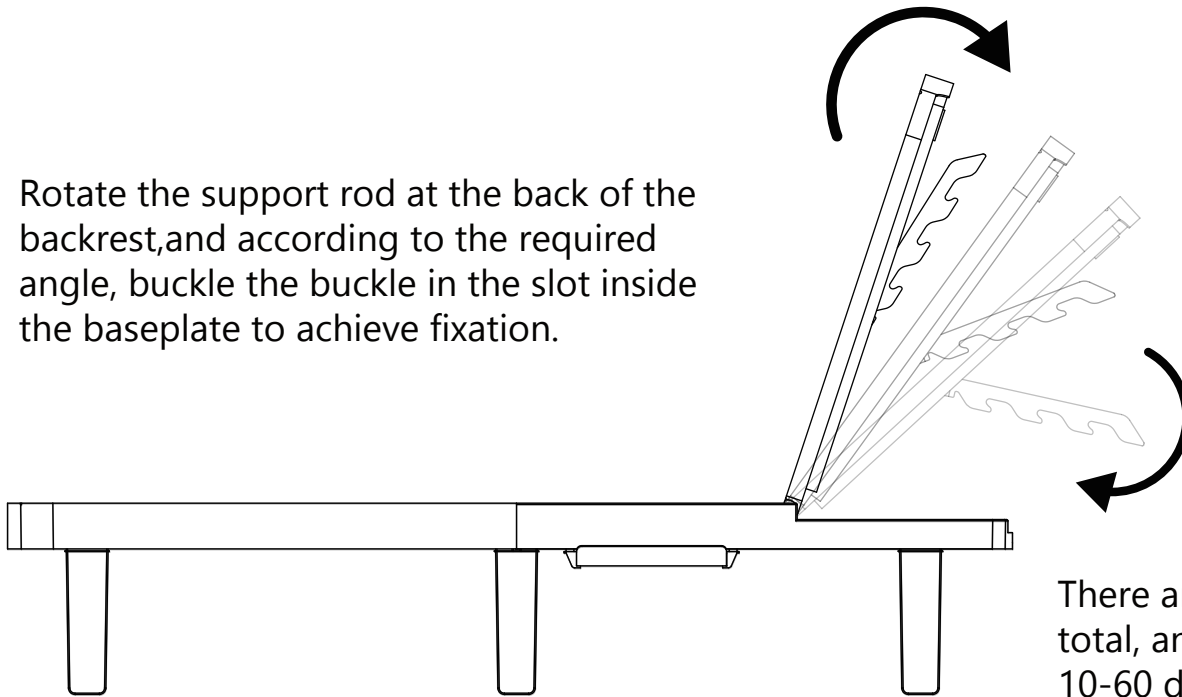

There are four gears in total, and the range is 10-60 degrees.

### Step 7

Arrange the chair plates and put them into the storage bag, which can be used for storage and mobile carrying.

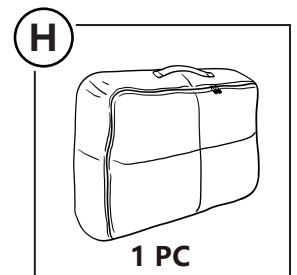
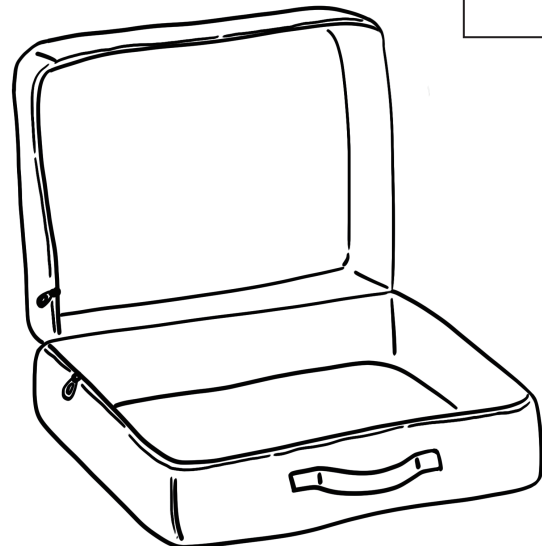
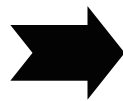
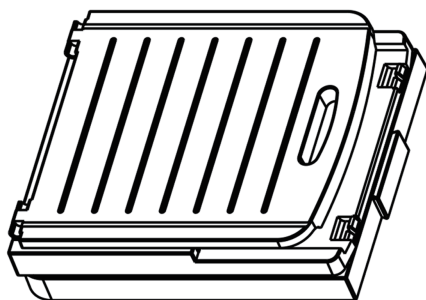

# AFTER-SALE SERVICE CARD

If you have any suggestions for our products or find that the products have quality problems, please contact us first, our after-sales team will reply you within 24 hours, and we will do our best to give you solutions until you are satisfied.

## Guaranteed Customer Service

Your shopping experience is very important to us!  
Feel unsatisfied? Contact us!  
Have any questions? Contact us!

Wanna Share how wonderful our smart products makes your home?  
Share your pictures with us.  
Any suggestions? Contact us!  
We gotcha back!