

ASSEMBLY INSTRUCTION

Before you begin, please follow assembly instruction carefully.
Then follow them step by step.

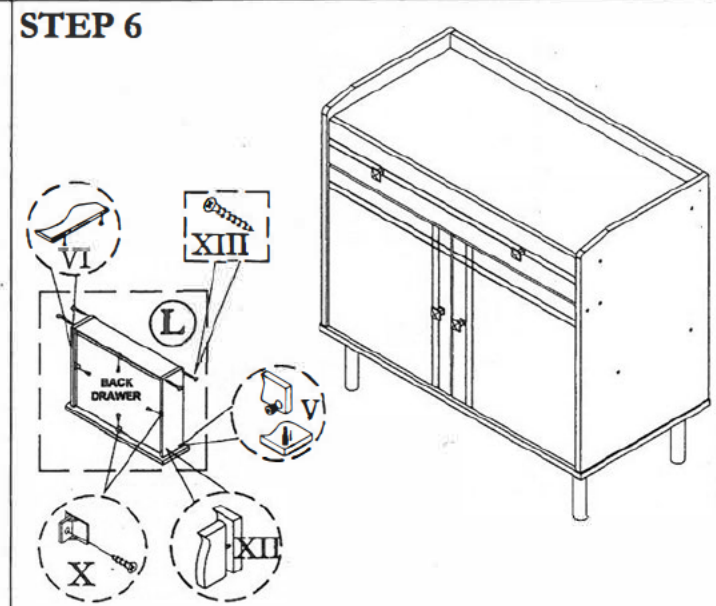
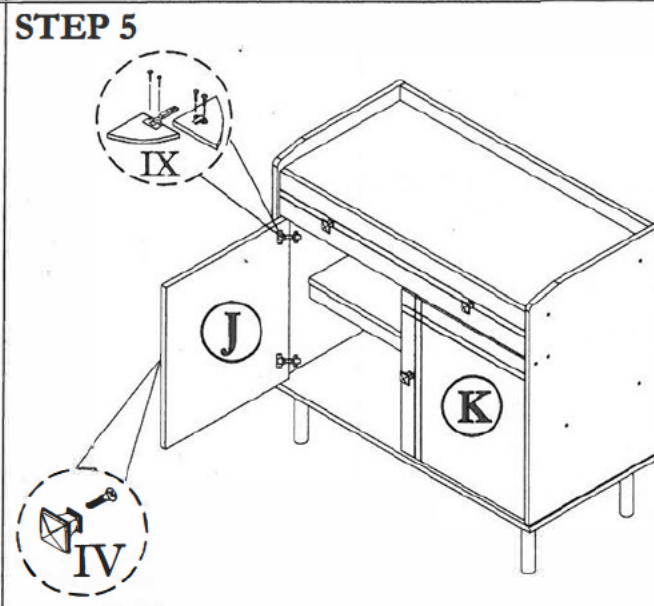
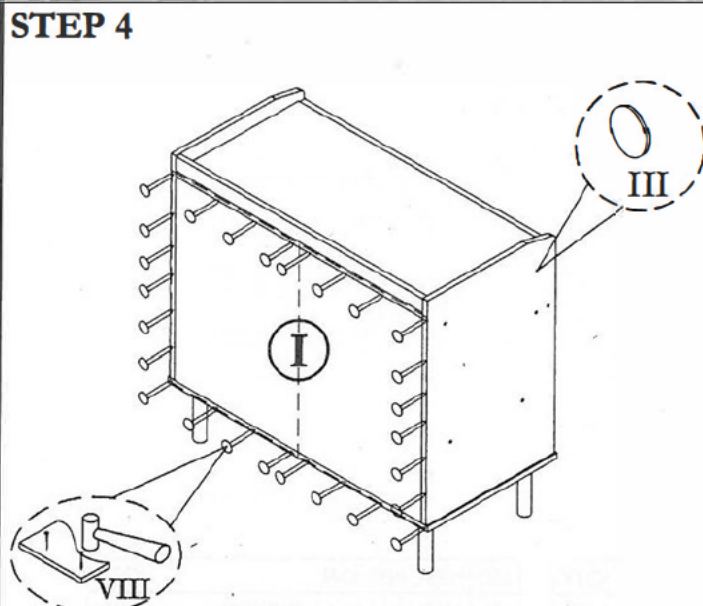
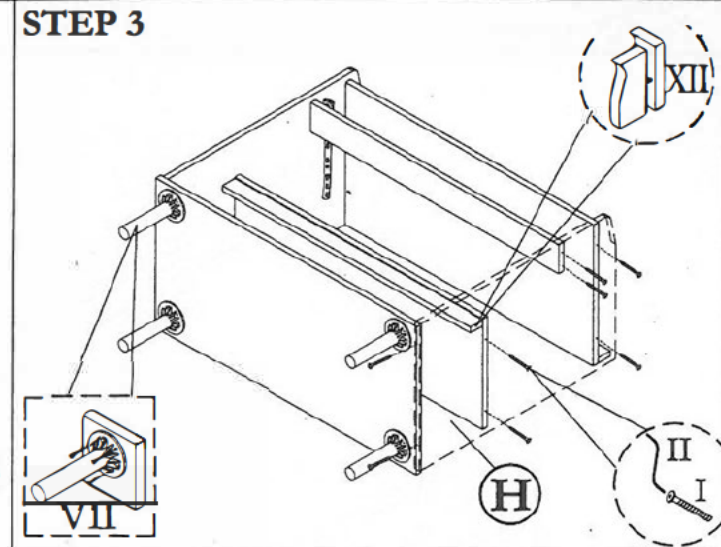
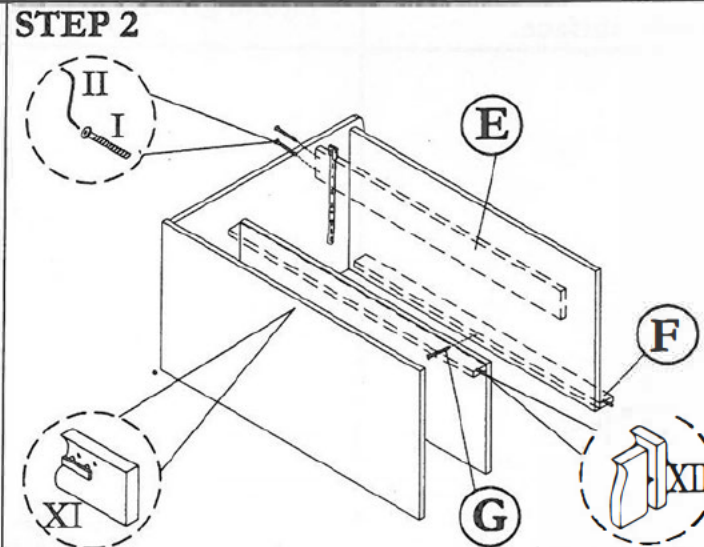
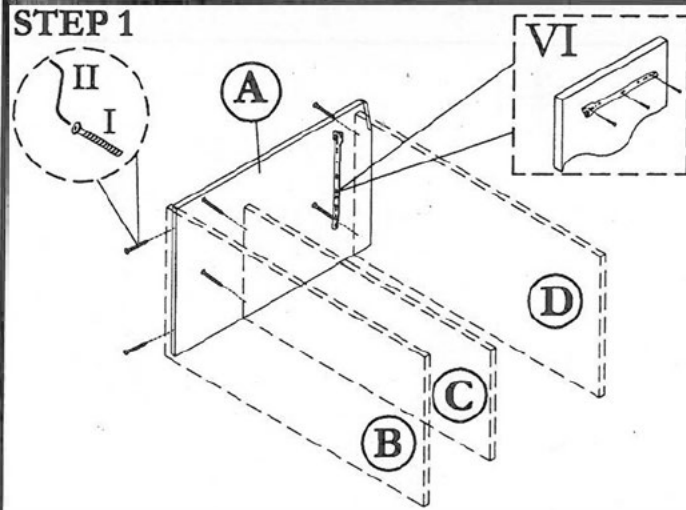

HARDWARE LIST

NO	DESCRIPTION	QTY
I	JCBCW SCREW M6.3 x 50	17pcs
II	M4 ALLEN KEY	1pc
III	STICKER	12pcs
IV	HANDLE & SCREW M4 x 22	4sets

V	Q-FIT	2sets
VI	12" DRAWER SLIDER & SCREW M3.5 x 16	1sets
VII	150MM P.LEG & SCREW M3.5 x 16	4sets
VIII	NAIL	40pcs
IX	HINGE (C) & SCREW M3.5 x 16	4sets
X	DRAWER SUPPORT & SCREW M3.5 x 12	4sets

XI	HIPS STOPPER & SCREW M3.5 x 16	1set
XII	M8 x 30 WOOD DOWEL	6pcs
XIII	M8 x 32 CHIPBOARD SCREW	4pcs

CAUTION:

To clean use soft, dry cloth. Do not use detergent or chemicals
 Avoid contact with water and direct sunlight.
 To be assembled on a soft, dry, clean and smooth surface.

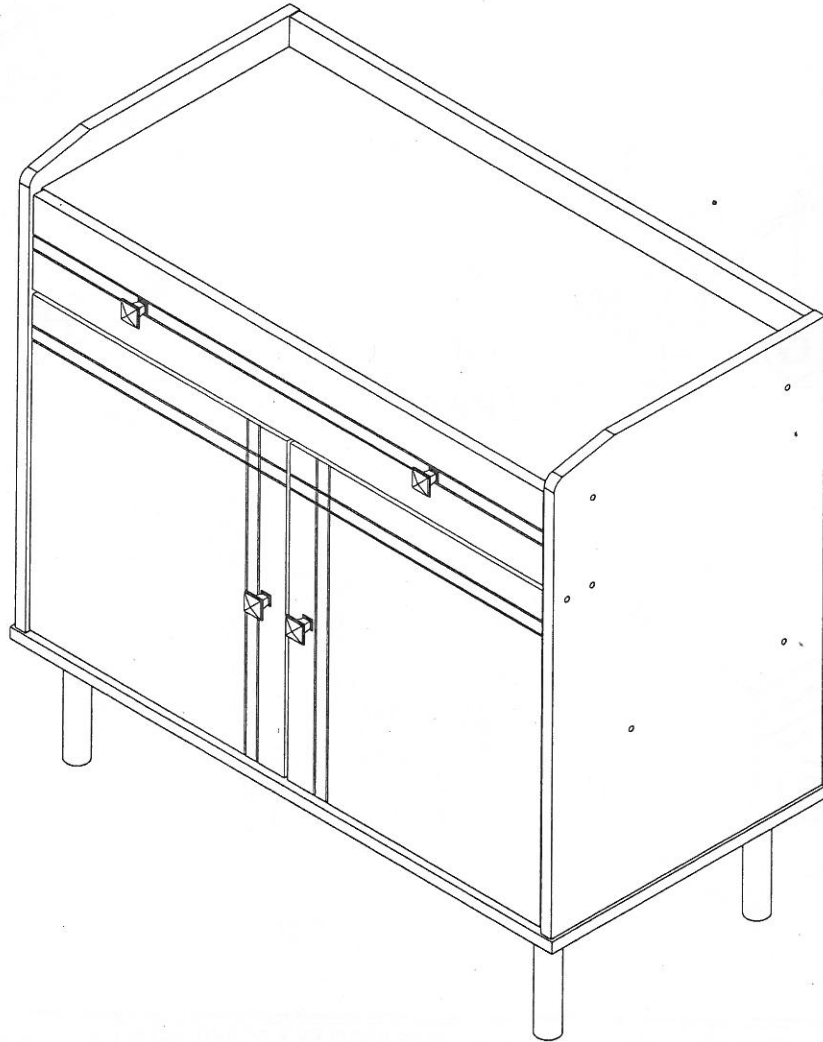

COMPLETE SET

ORDERING REPAIR PARTS

In order to obtain smooth and rapid service when ordering repair parts, please give full attention to the following of PART NUMBER.

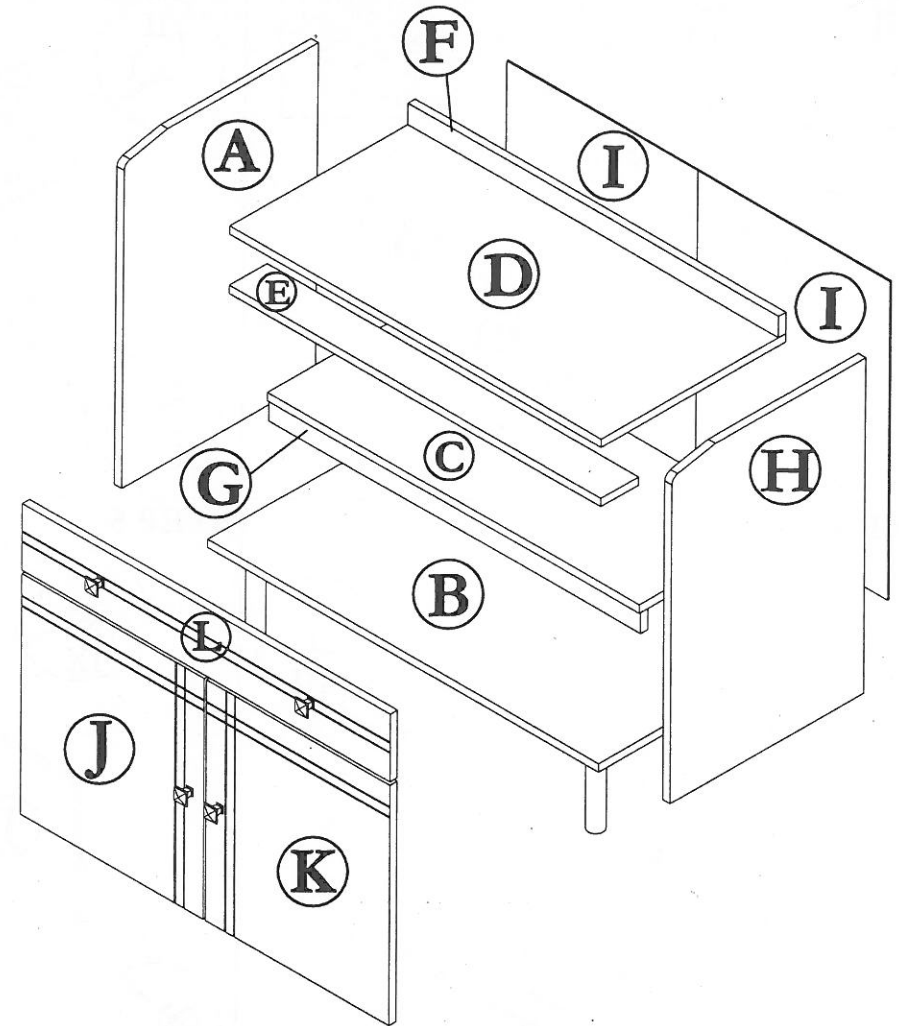

NO	DESCRIPTION	QTY
A	LEFT SIDE	01
B	LOWEST SHELF	01
C	CENTRE SHELF	01
D	UPPER SHELF	01
E	HORIZONTAL SHELF	01
F	BACK SUPPORT	01
	RIGHT SIDE (Bottom)	01

NO	DESCRIPTION	QTY
G	CENTRE SHELF SUPPORT	01
H	RIGHT SIDE	01
I	BACK	02
J	LEFT SIDE DOOR	01
K	RIGHT SIDE DOOR	01
L	DRAWER FACE	01