

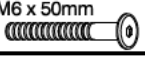





ASSEMBLY INSTRUCTIONS

- IMPORTANT NOTE :**
- * PLACE ALL WOODEN PARTS ON A CLEAN AND SMOOTH SURFACE SUCH AS A RUG OR CARPET TO AVOID THE PARTS FROM BEING SCRATCHED.
 - * BEFORE YOU BEGIN, KINDLY FOLLOW THE ASSEMBLY INSTRUCTIONS STEP BY STEP.
 - * DO NOT TIGHTEN ALL SCREWS UNTIL THE CHAIR IS FULLY SET-UP.

HARDWARE LIST			PART LIST		
A	JCBC SCREW M6 x 50mm 	8PCS	1	RIGHT SIDE FRAME	1PC
B	BARREL NUT M6 x 13mm 	8PCS	2	LEFT SIDE FRAME	1PC
C	FH SCREW #8 x 32mm 	4PCS	3	FRONT APRON	1PC
D	WOOD DOWEL M8 x 35mm 	8PCS	4	BACK APRON	1PC
E	ALLEN KEY M4 	1PC	5	TOP REST	1PC
F	JCBC W M6 X 40mm 	2PCS	6	TOP REST DOWN	1PC
			7	CENTER RAIL	1PC
			8	CHAIR SEAT	1PC

CAUTIONS :

(1) DO NOT FULLY-TIGHTEN THE NUT OR NUT BOLTS INITIALLY UNTIL ALL NUTS OR BOLT IS READY ASSEMBLED.

(TO AVOID CAUSING DAMAGES TO THE THREAD, DO NOT OVER-TIGHTEN THE NUTS OR BOLTS.)

(2) KEEP ALL HARDWARE PART OUT OF REACH OF CHILDREN.

STEP 1

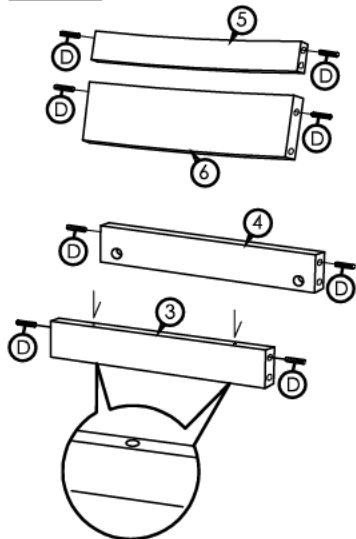

Front Apron has hole for screw.

STEP 2

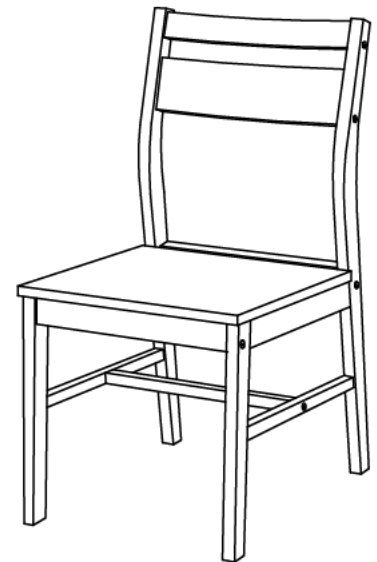
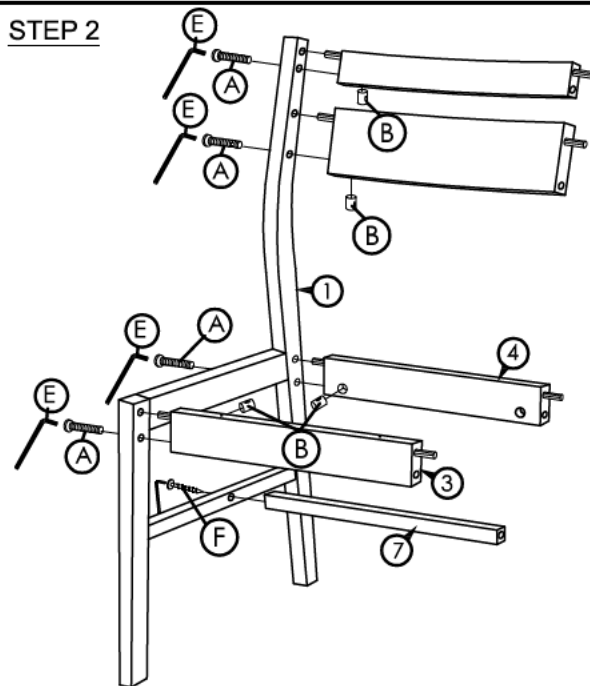

COMPLETED CHAIR ASSEMBLY.

STEP 3

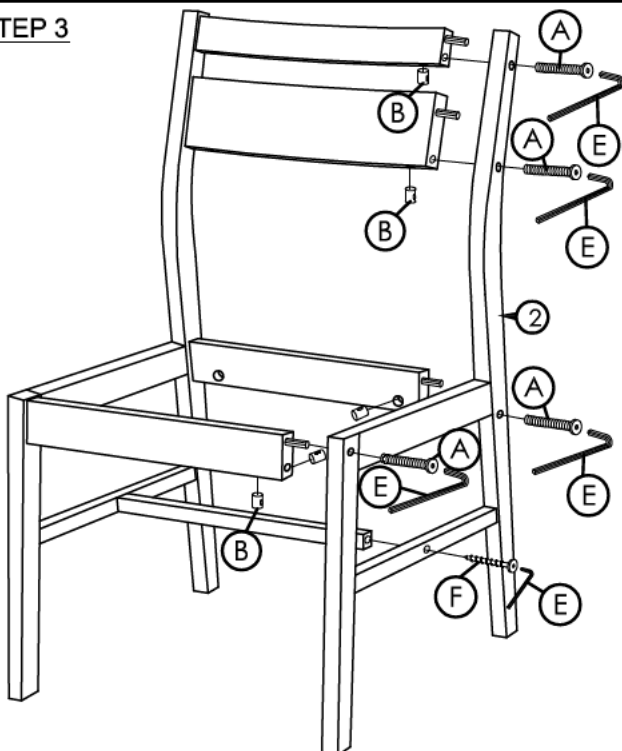

STEP 4

