

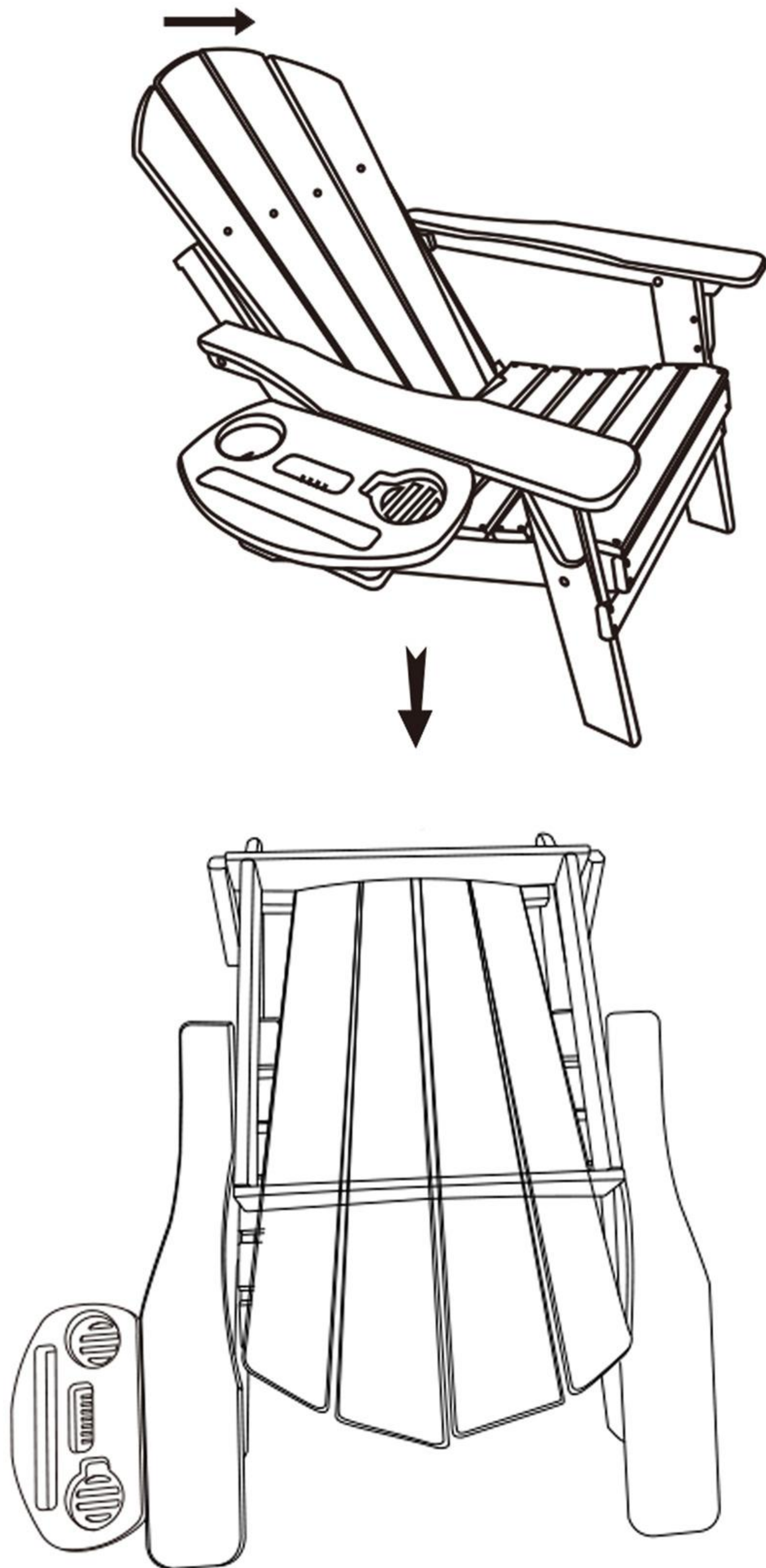

# Step 8

## Fold and Unfold This Recliner Chair

Before Folding this Chair, Kindly Push the Stool Back First and then Gently Fold the Chair's Backrest and Seat inwards.



 **Notice**

---

Please make sure to use dowels to completely connect the chair with the seat

---

 Please make sure that the plugs are not stuck in the middle

# Outdoor Folding

## Adirondack Chair

### Instruction Manual



# Thank you

Thank you for choosing us.

We hope your new furniture helps create a gathering place for you and your loved ones to enjoy for many years to come!

## Contact Us

**If you have any problem, please give us a chance to make it right for you!**

Contact our friendly customer service department for help first. Replacements for missing or damaged parts will be shipped ASAP!

## Before You Start

- Please read all instructions carefully.
- Retain instructions for future reference.
- Separate and count all parts and hardware.
- Read through each step carefully and follow the proper order.
- We recommend that, where possible, all items are assembled near to the area in which they will be placed in use, to avoid moving the product unnecessarily once assembled.
- Always place the product on a flat, steady and stable surface.
- Keep all small parts and packaging materials for this product away from babies and children.

### Assembly Procedure

## Step 7

**Adjust this Reclining Chair.**

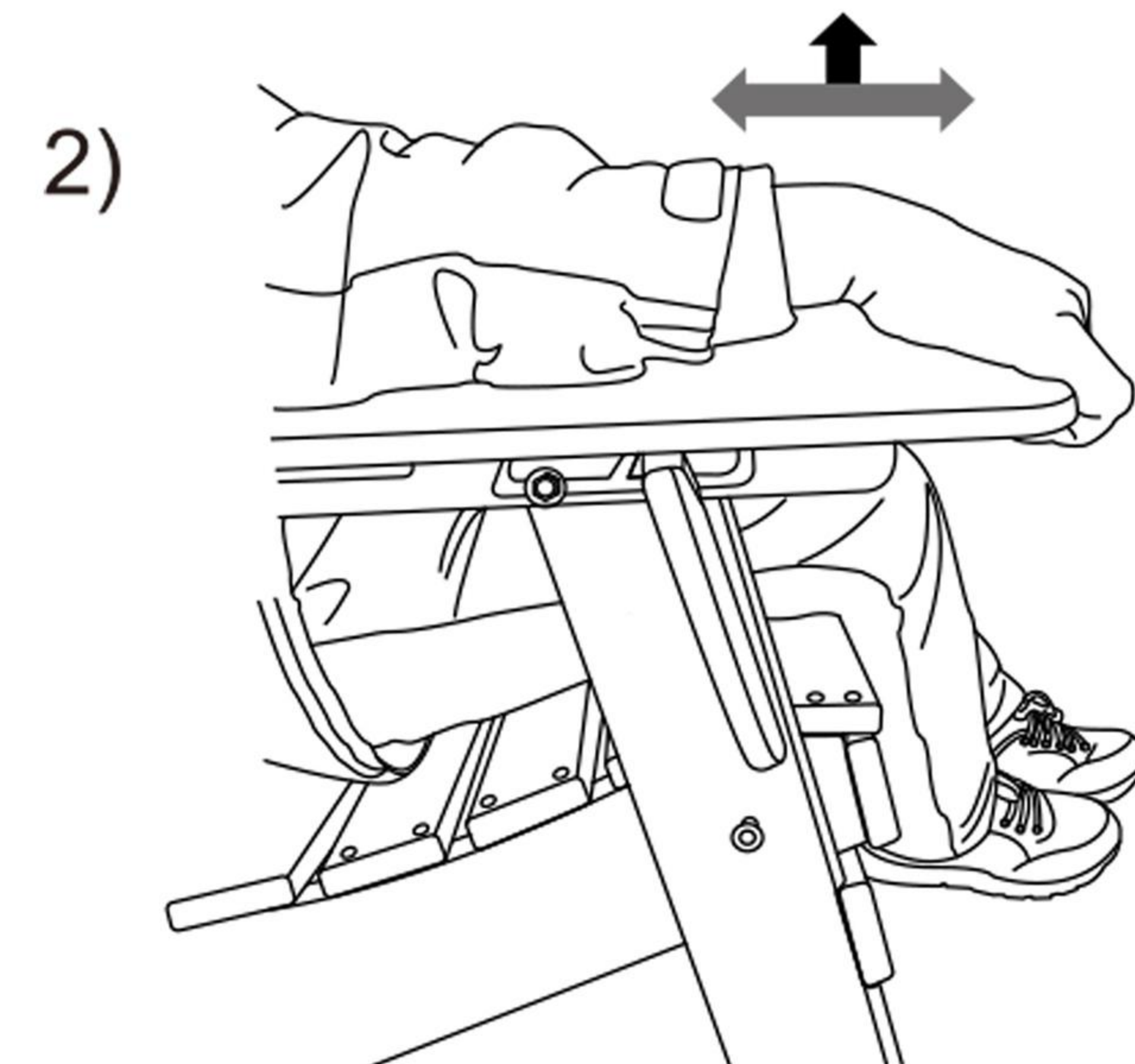
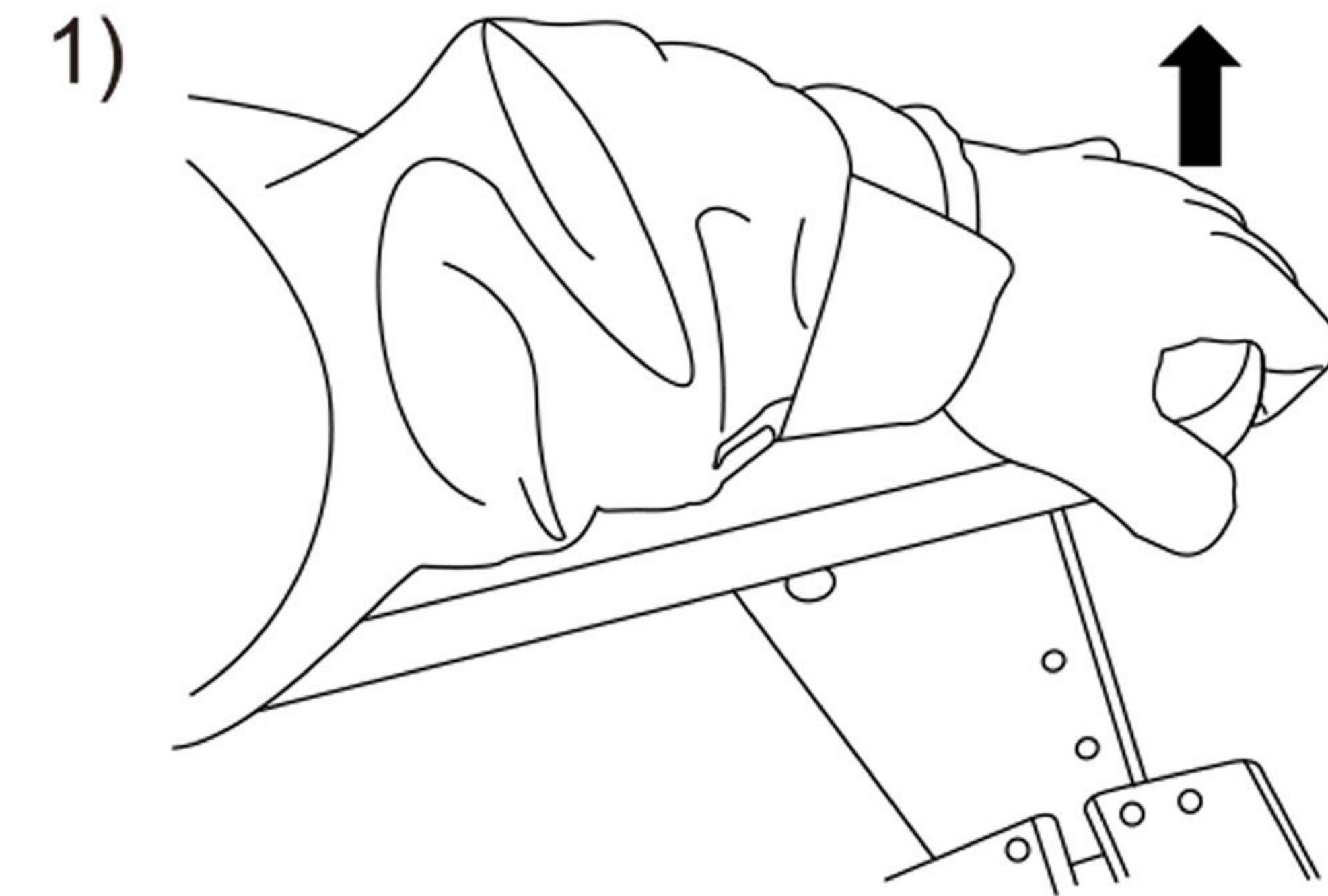

# Step 6



③ M6 x 50mm  
Bolt



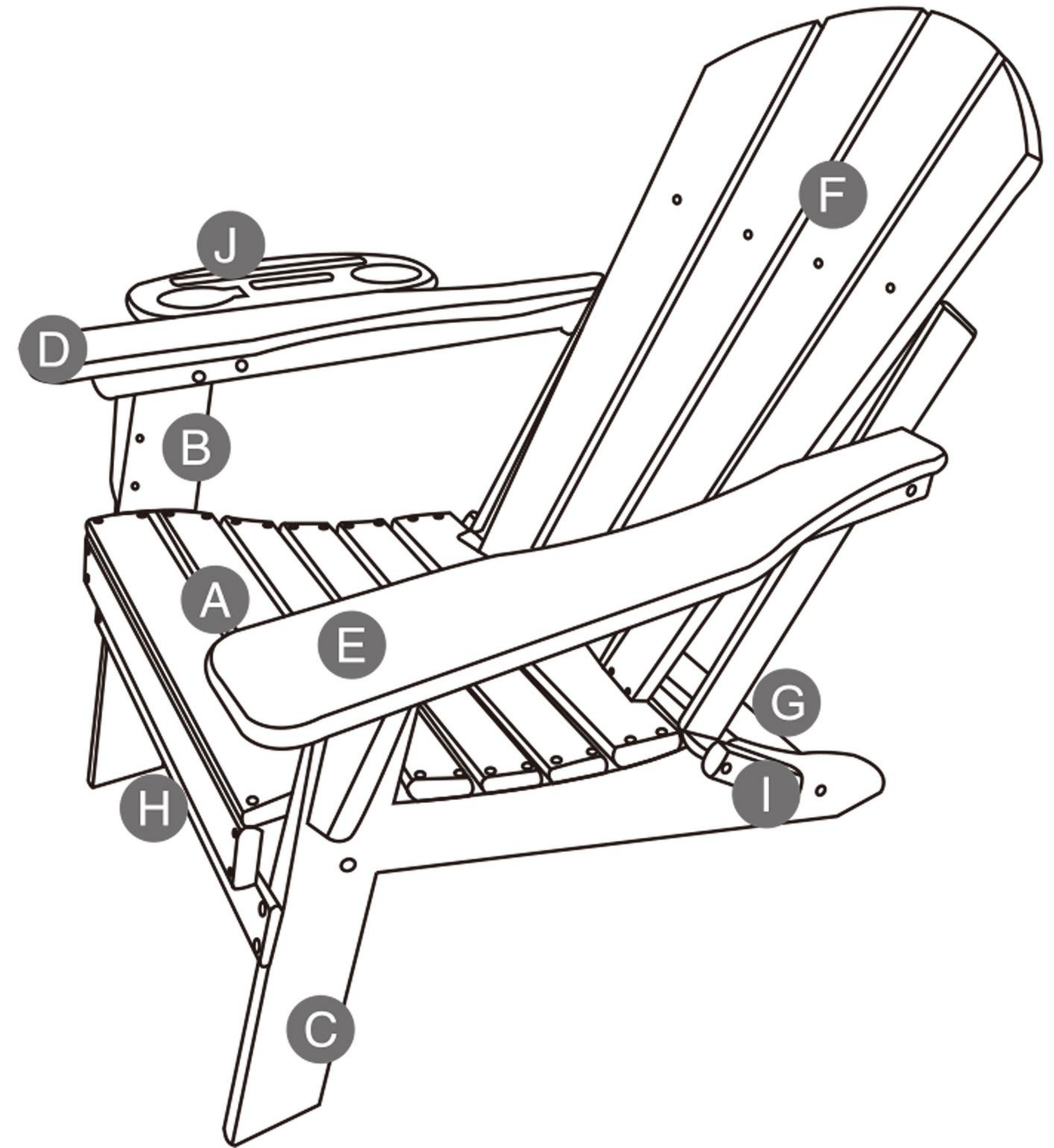
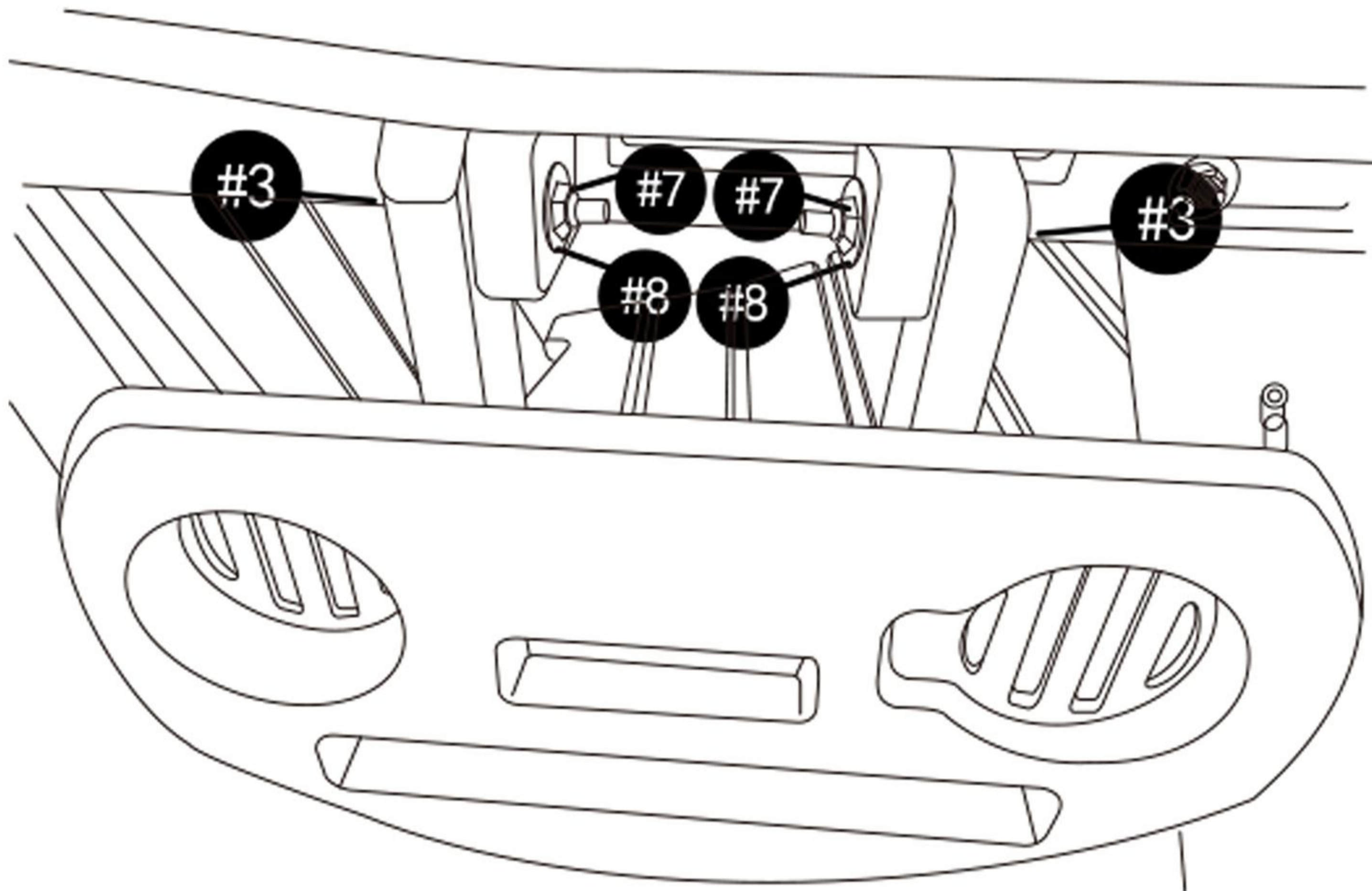

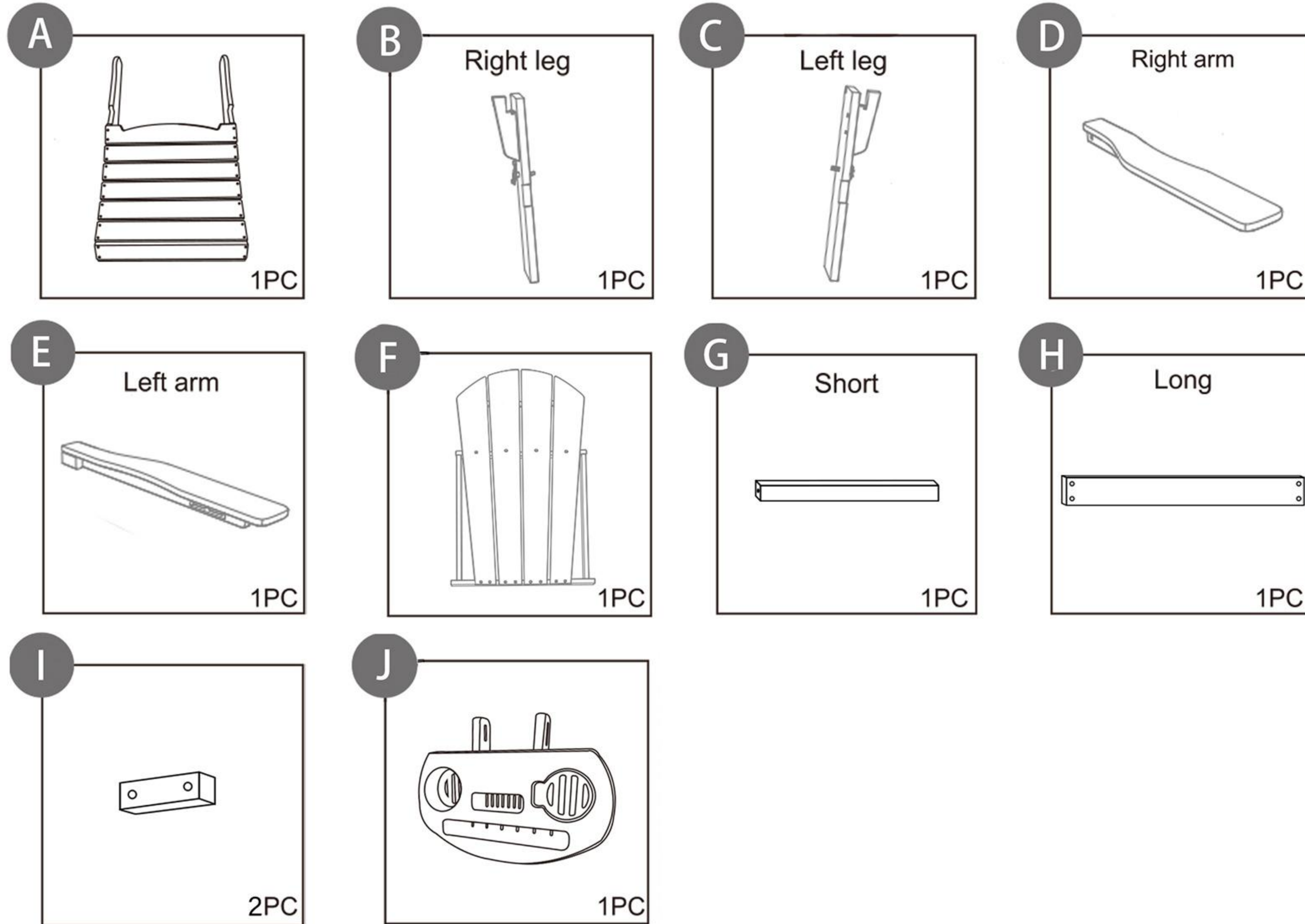

Secure Part J (4 in 1 Cup Holder Tray) to the Right Armrest,  
by using Hardware#3, Washer#7, Nuts#8

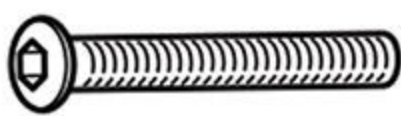
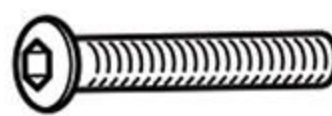
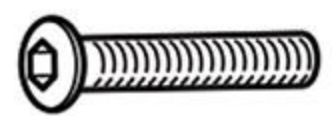
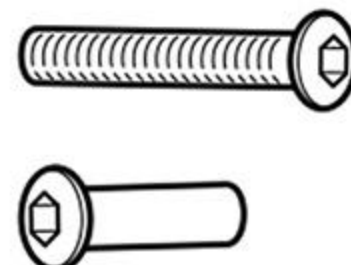

## PARTS LISTS

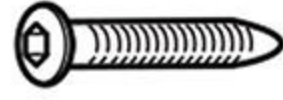

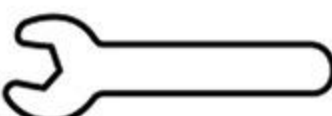
## HARDWARE LIST

|  |  |  |  |  |
|--|--|--|--|--|
| #1<br>M6 x 80mm<br>BOLT<br><br>2PCS   | #2<br>M6 x 60mm<br>BOLT<br><br>2PCS | #3<br>M6 x 50mm<br>BOLT<br><br>4PCS | #4<br>BOLT<br><br>2PCS   | #5<br>M6 x 60 mm<br>Screw<br><br>2PCS |
| #6<br>M6 x 40 mm<br>Screw<br><br>6PCS | #7<br>M6 WASHER<br><br>10PCS        | #8<br>M6 NUT<br><br>8PCS            | #9<br>SPANNER<br><br>1PC | #10<br>ALLEN KEY 4S<br><br>2PCS       |

## Assembly Procedure

### Step 5

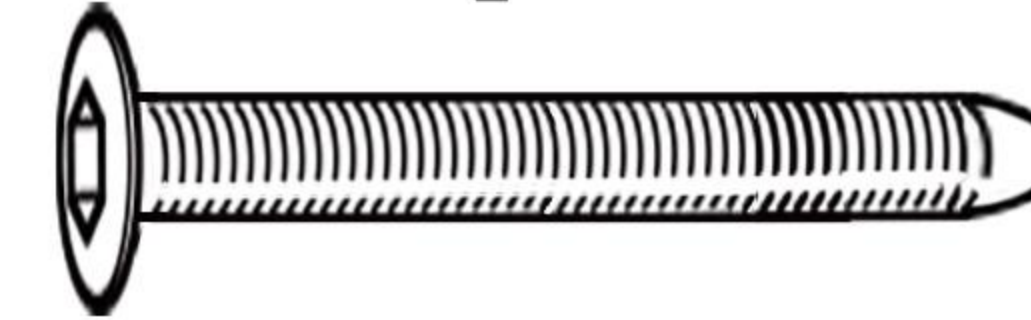

⑥ M6 x 40mm  
Screw

Connect Part G to the Seat Panel by using Hardware#6



⑤ M6 x 60mm  
Screw

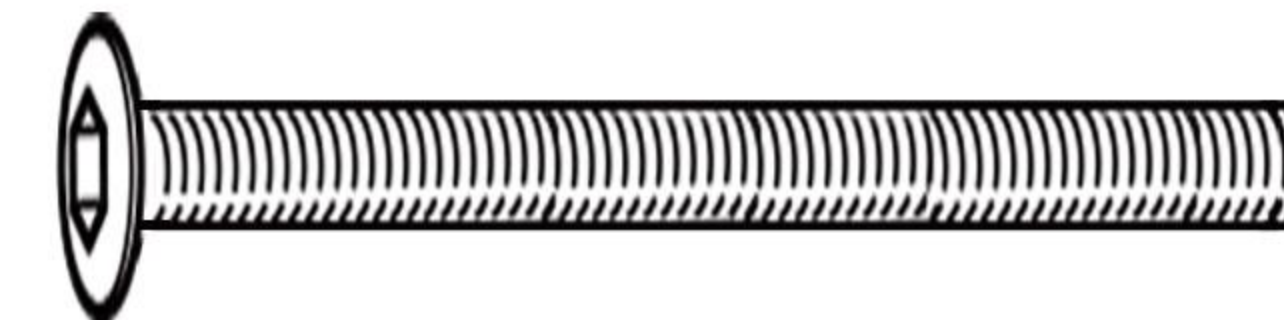

③ M6 x 50mm  
Bolt

Secure the Upper-hole of Part I to the Back Panel using Hardware#5

Secure the Lower-hole of Part I to the Seat Panel using

Hardware#3, Washer#7, Nuts#8

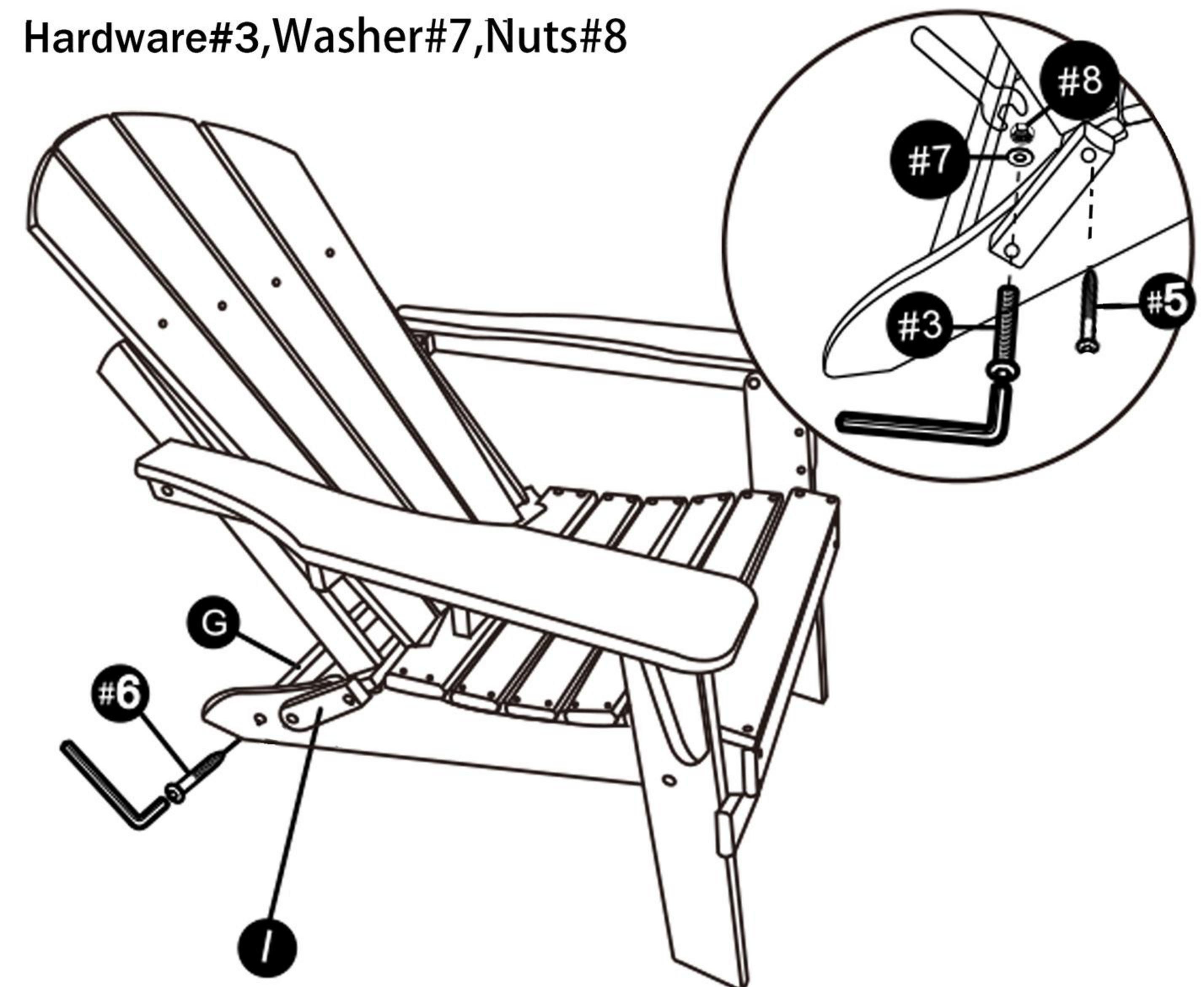

# Step 3

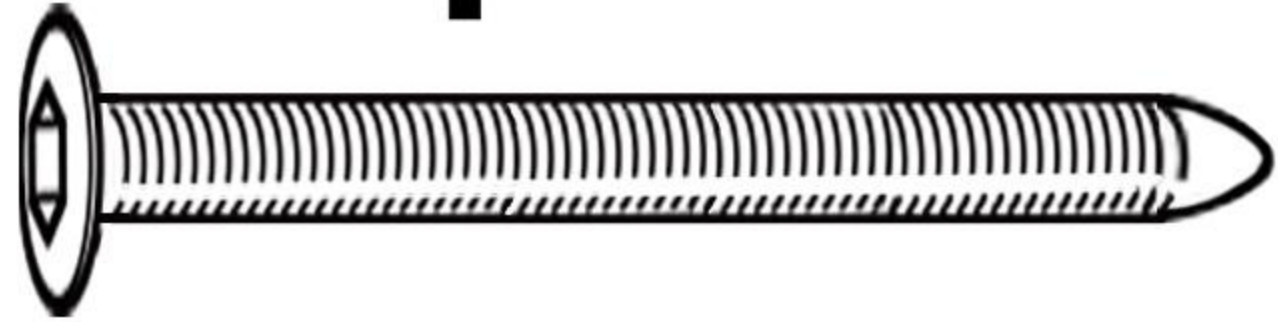

② M6 x 50mm  
Screw

Secure Part G to Part B & C using Hardware#2



⑥ M6 x 60mm  
Bolt

Assemble Part D(Right Arm) to the Right Leg,

Assemble Part E(Left Arm) to the Left Leg,

using Hardware#6,Washer#10,Nut#11

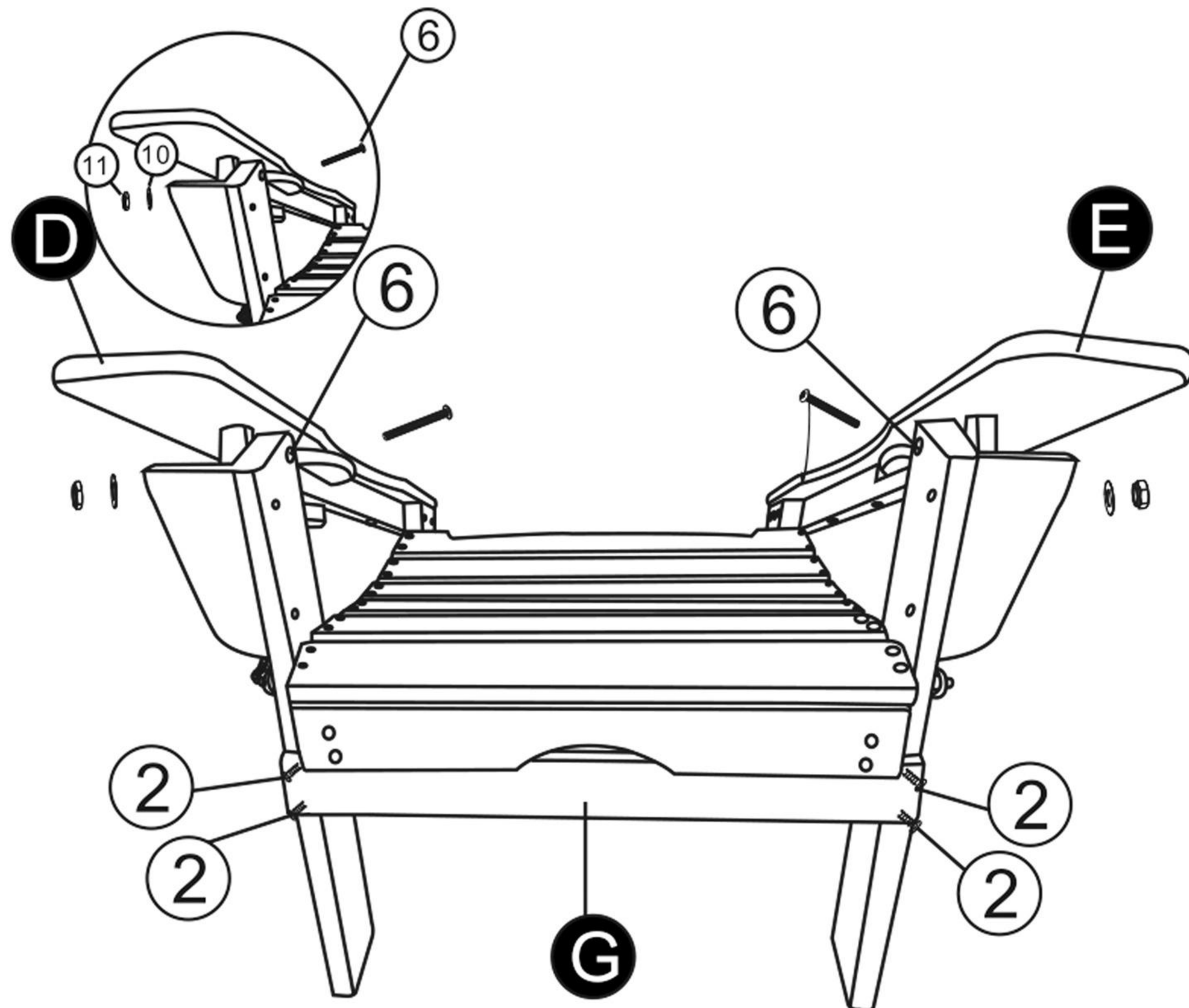

# Step 2

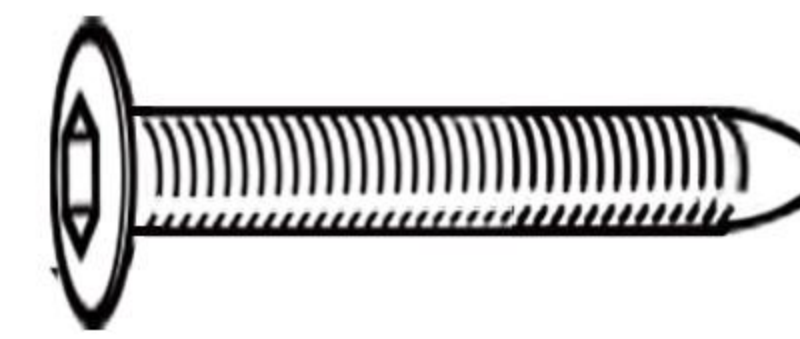

④ M6 x 30mm  
Screw

Assemble Part J (Cupholder) to Part D (Aramrest)

Assemble Part K (Cupholder) to Part E (Aramrest)

using Hardware#4

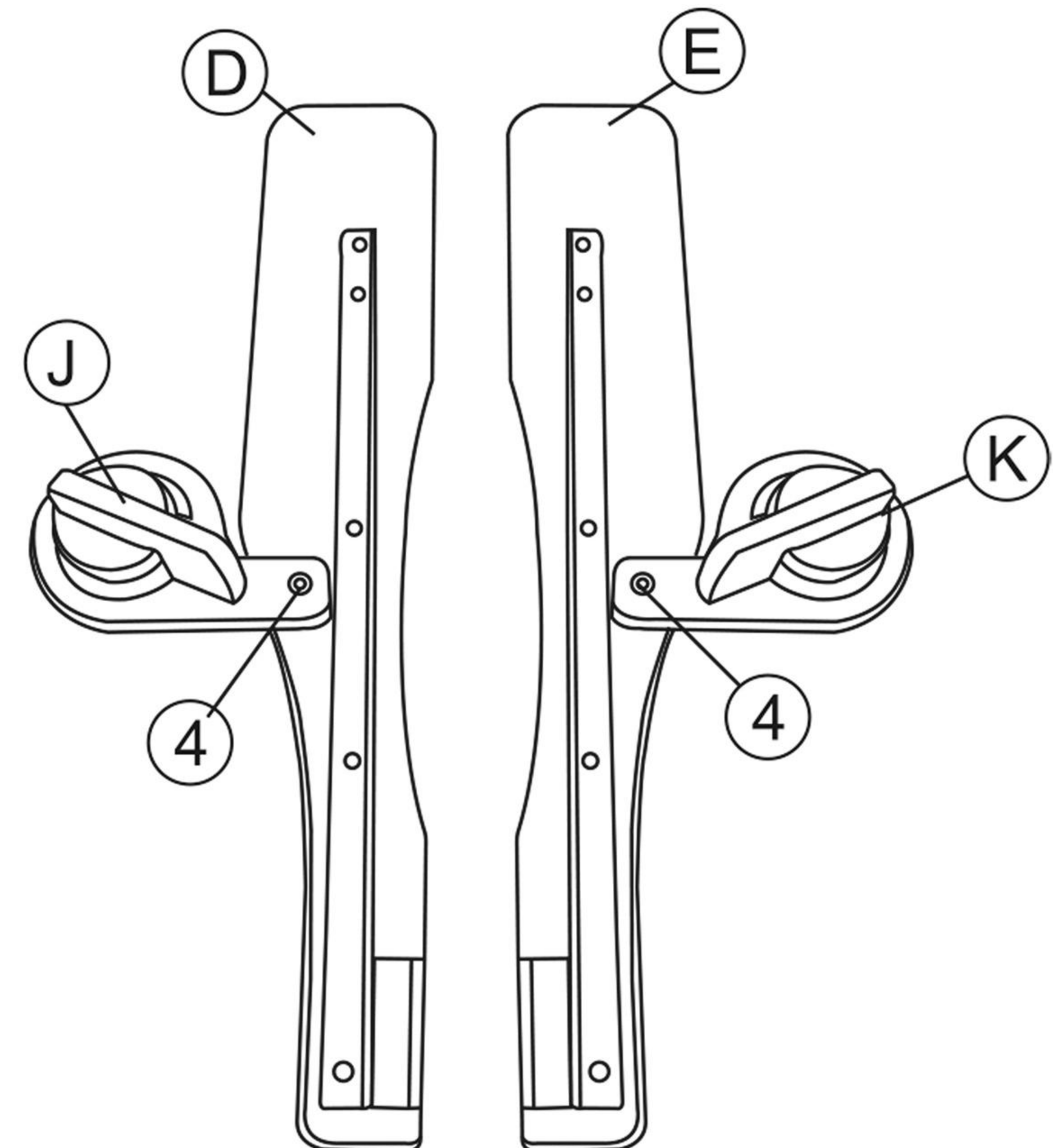

Assembly Procedure

# Step 1



⑥ M6 x 60mm Bolt

Assemble Part B&C to the PartA (seat panel) using Hardware#6,Washer#10,Nuts#11  
Tighten the chain Bolts on both legs.

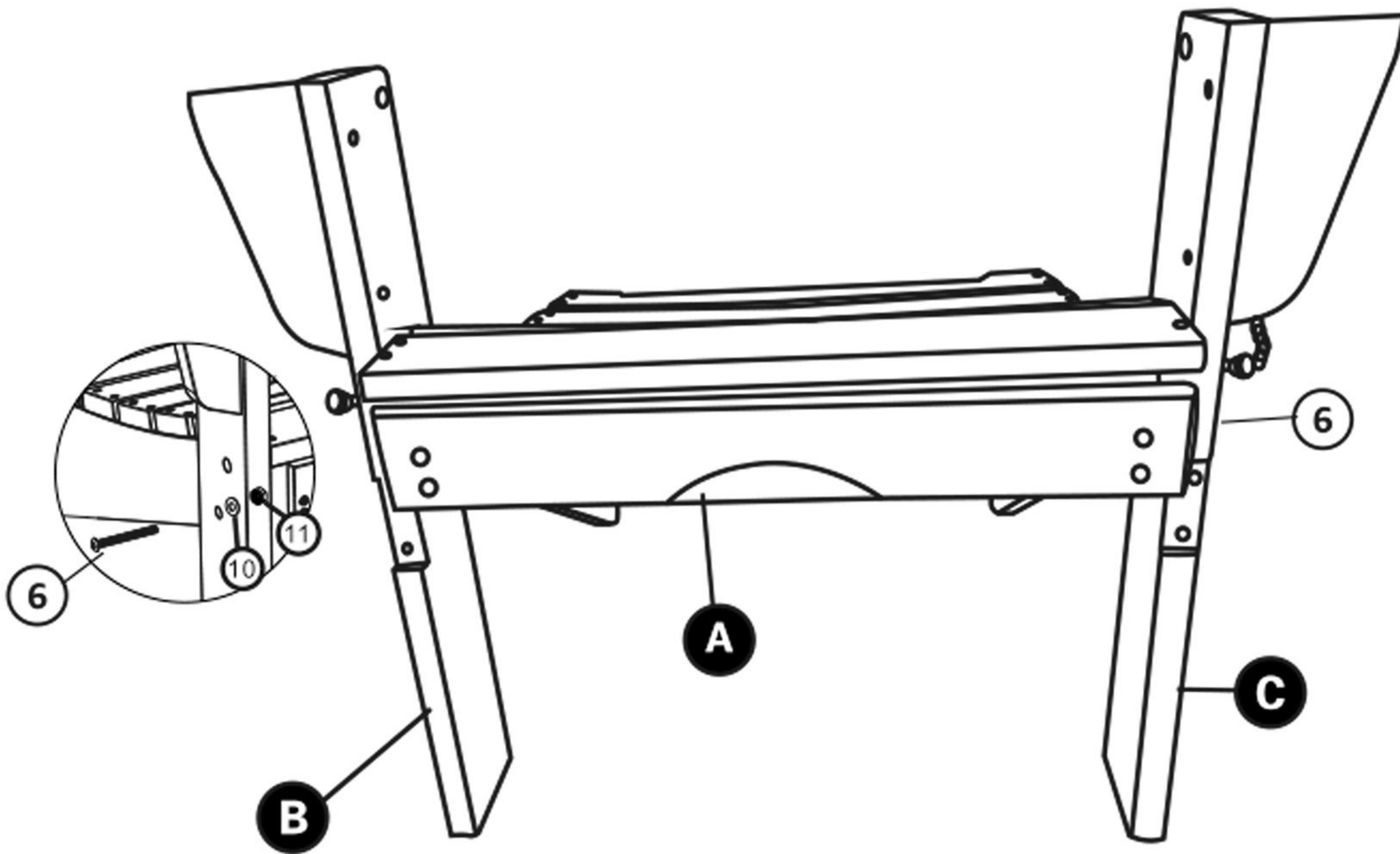

Assembly Procedure

# Step 4



⑦ M6 x 80mm Bolt

Assemble Part F(Back Panel) to the Armrests using Hardware#7,Washer#10,Nuts#11

