

SHOWER/EYEWASH STATION

6900K & 6900K-ADA ASSEMBLY INSTRUCTIONS

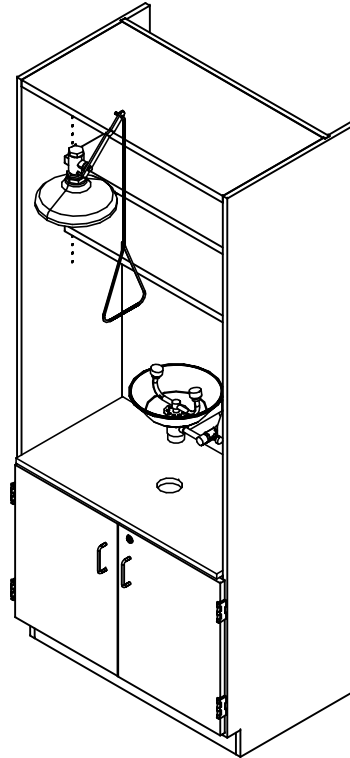

NOTE:

1. MODEL VIEWS MAY NOT REPRESENT EXACT MODEL PURCHASED

DWN BY:	EMK	DWN DATE:	4/9/15
APR BY:		DATE APR:	
APR BY:		DATE APR:	

UNLESS OTHERWISE SPECIFIED
DIMENSION ARE IN INCHES
CABINET SQUARENESS ± .0625
FRACTIONAL VALUES ± 1/32"
- ALL VALUES ± OVERALL -



300 South Krueger Street
Suring, WI 54174
diversifiedwoodcrafts.com

TITLE:
SHOWER/EYEWASH STATION
ASSEMBLY INSTRUCTIONS

REV.	DESCRIPTION	DATE	NAME	ECN NO.
A	CREATED ASSEMBLY INSTRUCTIONS	4/9/15	EMK	-
REVISION LEVEL				

THIS DRAWING IS THE SOLE PROPERTY OF
DIVERSIFIED WOOD CRAFTS. IT MAY NOT
BE ALTERED OR CHANGED WITHOUT
PERMISSION

DRAWING NUMBER:	SCALE:	SHEET:	REVISION:
6900K & 6900K-ADA	NTS	1 OF 3	REV A

TOOLS REQUIRED

CONTACT CEMENT

SCREW DRIVER

ASSEMBLY COMPONENTS

ITEMS INCLUDED	PART #	PART DESCRIPTION	QTY
RUBBER BASE MOLDING	100283	RUBBER BASE MOLDING (SOLD BY FOOT)	13.5
STAINLESS STEEL CORNERS	100057	CORNERS-STAINLESS STEEL,BASE	4
SCREWS-BASE	100064	SCREW,#6X 1/2 PTH SMS SS SCREW	16
SHELF CLIPS	100027	SHELF CLIPS,PLASTIC,5MM PIN	12
FIXTURE	100615	FIXTURE,EW814 WALL MNT. EYEWASH	1
FIXTURE	100614	FIXTURE,ES635 VERTICAL MTD SHOWER	1
FIXTURE	226460	FIXTURE,ES643 W/47.5 PULL ROD ADA	1
FIXTURE	100633	FIXTURE, EW808 EYEWASH FOR ADA UNIT	1

NOTE:

1. ****XX**** INDICATES ITEMS USED ONLY FOR THE 6900K-ADA.

DWN BY:	EMK	DWN DATE:	4/9/15
APR BY:		DATE APR:	
APR BY:		DATE APR:	

UNLESS OTHERWISE SPECIFIED
DIMENSION ARE IN INCHES
CABINET SQUARENESS ± .0625
FRACTIONAL VALUES ± 1/32"
- ALL VALUES ± OVERALL -



300 South Krueger Street
Suring, WI 54174
diversifiedwoodcrafts.com

TITLE:
SHOWER/EYEWASH STATION
TOOLS AND ASSEMBLY COMPONENTS

REV.	DESCRIPTION	DATE	NAME	ECH NO.
A	CREATED ASSEMBLY INSTRUCTIONS	4/9/15	EMK	-

REVISION LEVEL

THIS DRAWING IS THE SOLE PROPERTY OF
DIVERSIFIED WOOD CRAFTS. IT MAY NOT
BE ALTERED OR CHANGED WITHOUT
PERMISSION

DRAWING NUMBER:

6900K & 6900K-ADA

SCALE:

NTS

SHEET:

2 OF 3

REVISION:

REV A

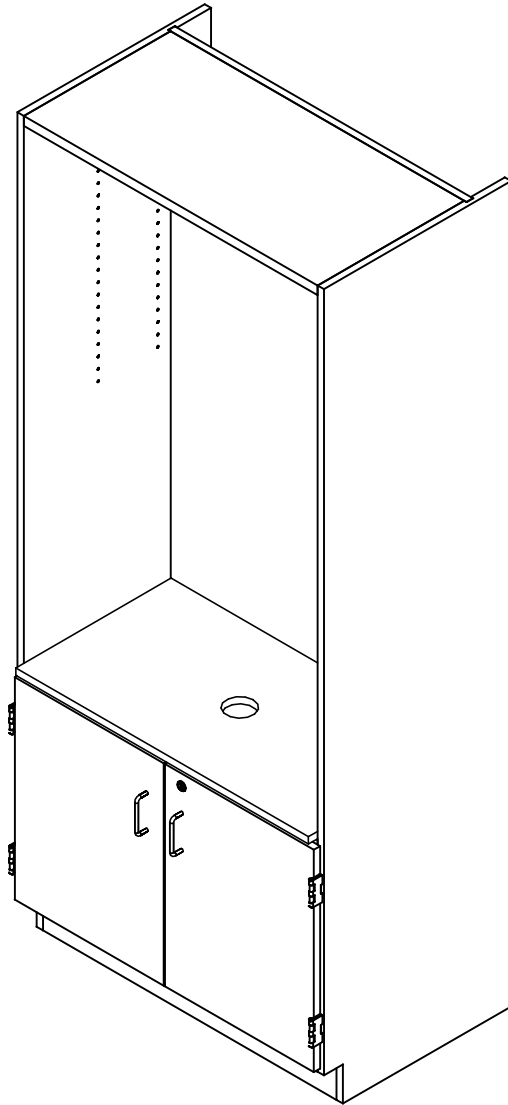

STEP 1:

- POSITION CABINET IN YOUR DESIRED LOCATION.
- LEVEL THE CABINET.
- ANCHOR TO WALL AS CABINET WILL BE TOP HEAVY.

****NOTE****
 CABINET MUST BE LEVEL OR
 DOORS AND DRAWERS MAY NOT
 OPEN OR CLOSE CORRECTLY

NOTE:

1.

DWN BY:	EMK	DWN DATE:	4/9/15
APR BY:		DATE APR:	
APR BY:		DATE APR:	

UNLESS OTHERWISE SPECIFIED
 DIMENSION ARE IN INCHES
 CABINET SQUARENESS ± .0625
 FRACTIONAL VALUES ± 1/32"
 - ALL VALUES ± OVERALL -



300 South Krueger Street
 Suring, WI 54174
 diversifiedwoodcrafts.com

TITLE:
 SHOWER/EYEWASH STATION
 ASSEMBLY INSTRUCTIONS

REV.	DESCRIPTION	DATE	NAME	ECN NO.
A	CREATED ASSEMBLY INSTRUCTIONS	4/9/15	EMK	-

THIS DRAWING IS THE SOLE PROPERTY OF
 DIVERSIFIED WOOD CRAFTS. IT MAY NOT
 BE ALTERED OR CHANGED WITHOUT
 PERMISSION

DRAWING NUMBER:	SCALE:	SHEET:	REVISION:
6900K & 6900K-ADA	NTS	3 OF 3	REV A

ADJUSTABLE
SHELVES - TYPICAL

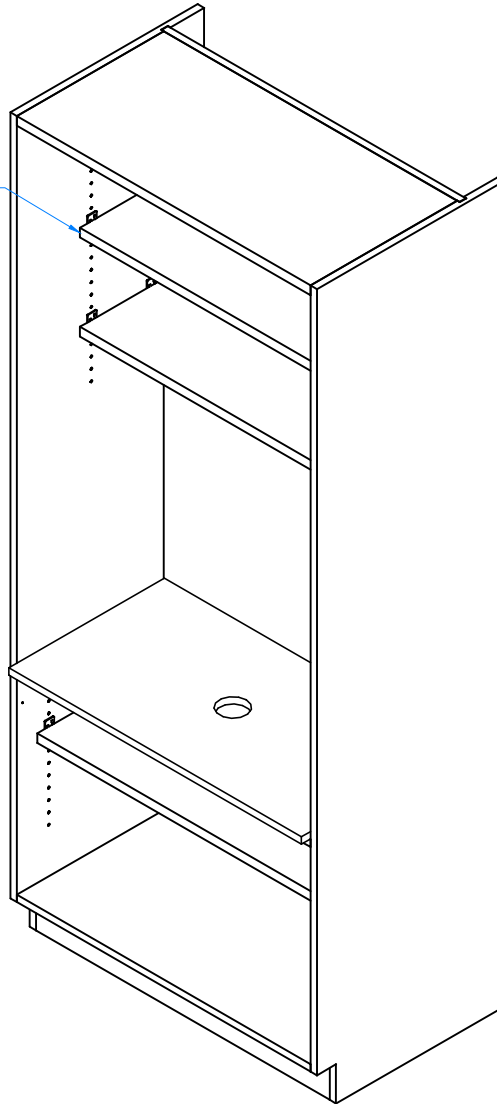

DOORS AND HARDWARE REMOVED TO
SHOW CLARITY

STEP 2:

- INSERT SHELF CLIPS IN DESIRED LOCATION.
- PLACE SHELVES ON CLIPS, MAKING SURE THEY ARE LEVEL.

NOTE:

1.

DWN BY:	EMK	DWN DATE:	4/9/15
APR BY:		DATE APR:	
APR BY:		DATE APR:	



300 South Krueger Street
Suring, WI 54174
diversifiedwoodcrafts.com

UNLESS OTHERWISE SPECIFIED
DIMENSION ARE IN INCHES
CABINET SQUARENESS ± .0625
FRACTIONAL VALUES ± 1/32"
- ALL VALUES ± OVERALL -

THIS DRAWING IS THE SOLE PROPERTY OF
DIVERSIFIED WOOD CRAFTS. IT MAY NOT
BE ALTERED OR CHANGED WITHOUT
PERMISSION

TITLE:
SHOWER/EYEWASH STATION
ASSEMBLY INSTRUCTIONS

REV.	DESCRIPTION	DATE	NAME	ECN NO.
A	CREATED ASSEMBLY INSTRUCTIONS	4/9/15	EMK	-
REVISION LEVEL				

DRAWING NUMBER:	SCALE:	SHEET:	REVISION:
6900K & 6900K-ADA	NTS	3 OF 3	REV A

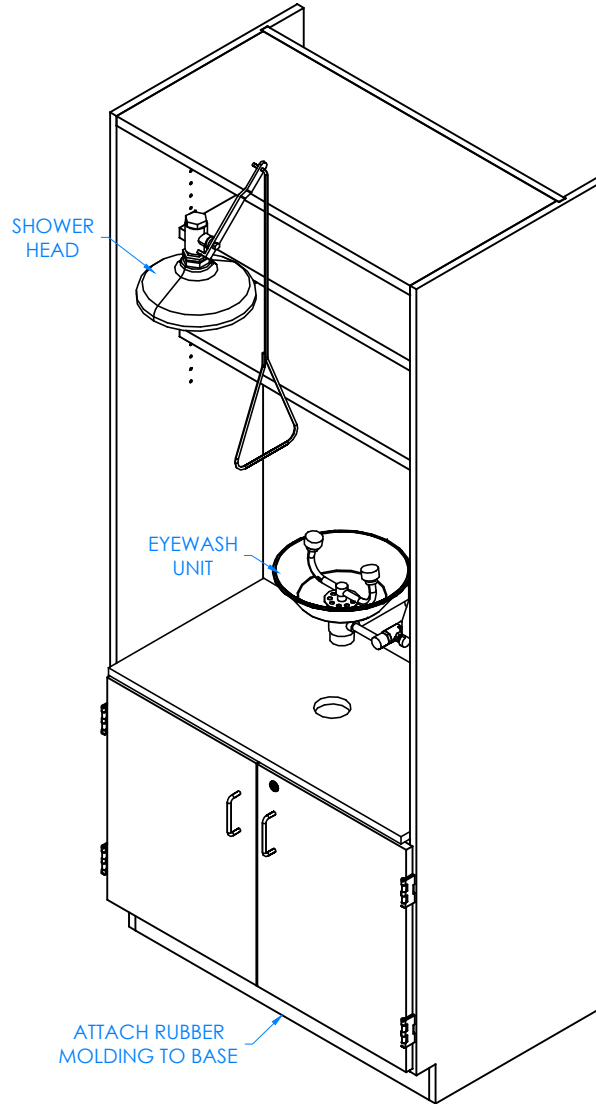

STEP 3:

- IF YOU HAVE A 6900K UNIT, ATTACH RUBBER MOLDING TO BASE OF CABINET USING CONTACT CEMENT.
- SCREW STAINLESS STEEL CORNER BRACKETS ON EACH CORNER OVER BASE MOLDING WITH HARDWARE PROVIDED.
- ATTACH SHOWER HEAD AND EYEWASH UNIT.

NOTE:

1. ALL PLUMBING NEEDS TO BE DONE BY A LICENSED PLUMBER PER LOCAL CODE.

COMPLETE UNIT SHOWN

REV.	DESCRIPTION	DATE	NAME	ECH NO.
A	CREATED ASSEMBLY INSTRUCTIONS	4/9/15	EMK	-
REVISION LEVEL				

DWN BY:	EMK	DWN DATE:	4/9/15
APR BY:		DATE APR:	
APR BY:		DATE APR:	

UNLESS OTHERWISE SPECIFIED
DIMENSION ARE IN INCHES
CABINET SQUARENESS ± .0625
FRACTIONAL VALUES ± 1/32"
- ALL VALUES ± OVERALL -

THIS DRAWING IS THE SOLE PROPERTY OF
DIVERSIFIED WOOD CRAFTS. IT MAY NOT
BE ALTERED OR CHANGED WITHOUT
PERMISSION



300 South Krueger Street
Suring, WI 54174
diversifiedwoodcrafts.com

TITLE:
**SHOWER/EYEWASH STATION
ASSEMBLY INSTRUCTIONS**

DRAWING NUMBER: 6900K & 6900K-ADA	SCALE: NTS	SHEET: 5 OF 5	REVISION: REV A
---	---------------	------------------	--------------------