

# Instruction booklet



The type and quantity of components may vary for different style sheds. Assembly of all shed styles is by the same method as detailed.

Before assembling the shed, please check that all parts are present.

Report any shortages or other issues immediately.

No.	Components	Number
1	Front panel	1
2	Rear panel	1
3	side panels	4
4	Felt	1
5	Roof diamond	2
6	Floor	2
7	Roof panels	4
8	Door	1 or 2
9	Windows	Optional
10	Window bead 15mm x 20mm	Optional
11	Floor bearers tanalised 26mm x 38mm	Variable
12	Barge boards 11mm x 41mm	4
13	Tee Hinges	3 (single door) 6 (double door)
14	Turn button	1 (single door) 2 (double door)
15	cover strips 11mm x 41mm	6
16	Hasp and Staple	1

Adequate provision must be made to ensure that the floor boards of the building do not come into direct contact with the ground and air is able circulate underneath. A concrete or paving slab base is acceptable, but the building must not be allowed to sit in pooled water during wet conditions.

**Timber Information.** Timber is a natural product and can therefore be subject to warping, shrinkage, splitting etc...Periods of excessive dry spells can cause the timber to lose internal moisture resulting in shrinkage on a panel. During periods of excessive wet spells, the timber may experience some swelling. Unfortunately this process cannot be avoided. If you have problems with certain boards shrinking, try to decrease the amount of direct sunlight it gets. During hot spells spray any shrunken boards with a hosepipe, this will replenish the moisture in the timber.

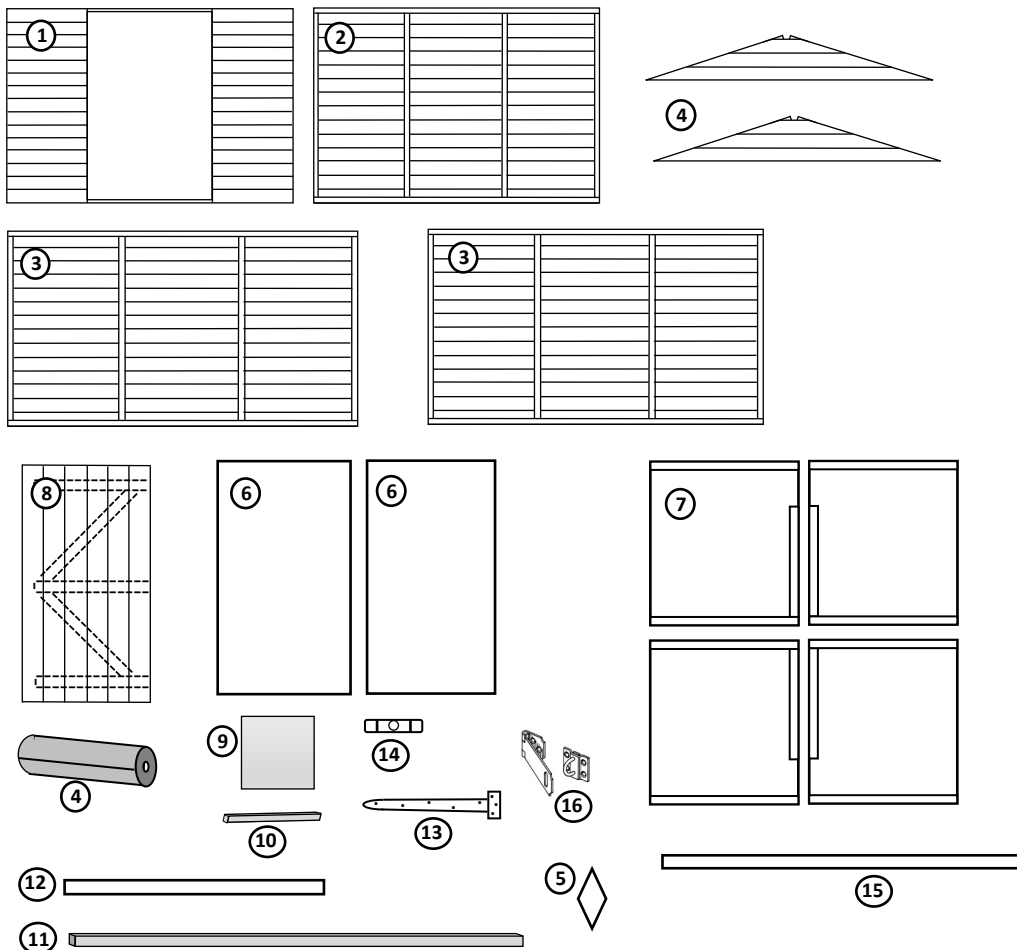

Fixings		
60mm screws		32mm ringshank nails
40mm screws		13mm clout nails
25mm black screws		30mm panel pins (windows options only)

## 1. Floor Section

The floor and floor bearers are supplied separately.

The ROOF is supplied with batons already attached.

Depending on the size of your shed, you will have either 3 or 4 floor boards, which should be fixed together as shown below.

Attach the floor bearers as shown below. Starting at one end, place each floor bearer approx. 30cms apart, ensuring that one bearer is fixed along both outer edges of the floor. Where two boards meet, ensure that they are joined together onto one floor bearer as shown below.

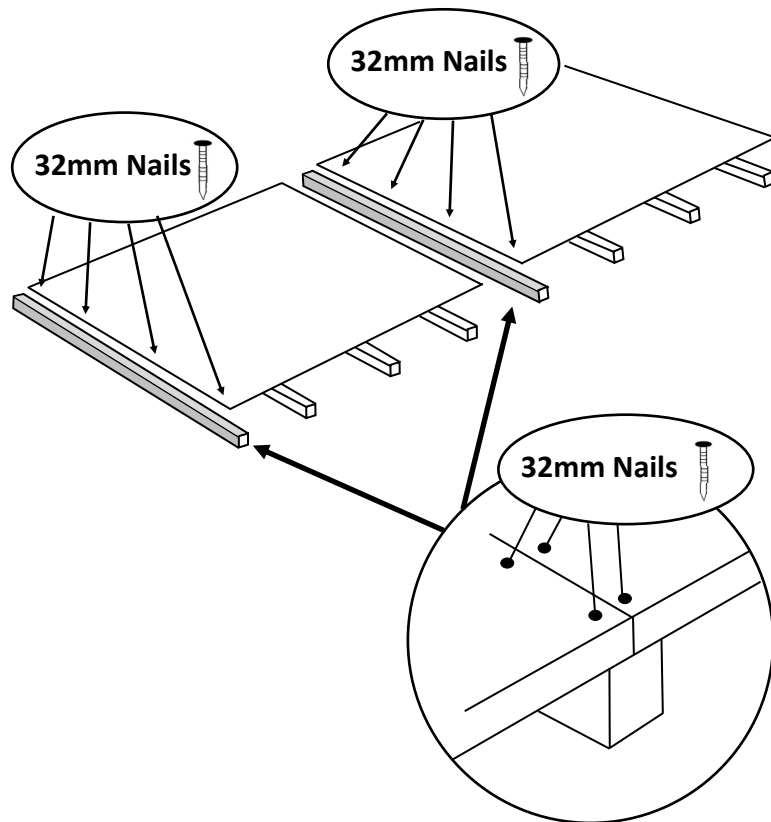

## 2. Wall Panels

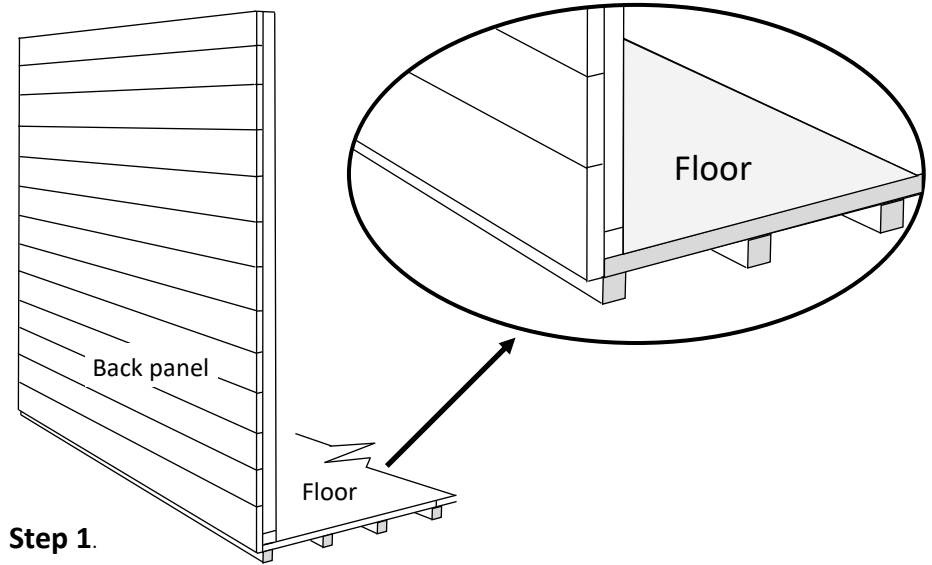

### Step 1.

Position the back panel so that the edge of the panel is flush with the edge of the floor at both ends and the overhang on the bottom of the panel is butted up to the floor. This panel is the same width as the floor board.

### Step 2.

Position the corresponding front or rear panel next to the end panel, to make a corner. The cladding of the front/rear panel should be proud of the end panel to allow fitting of the corner cover strips, as shown below. Next screw the remaining panels into place using the same method.

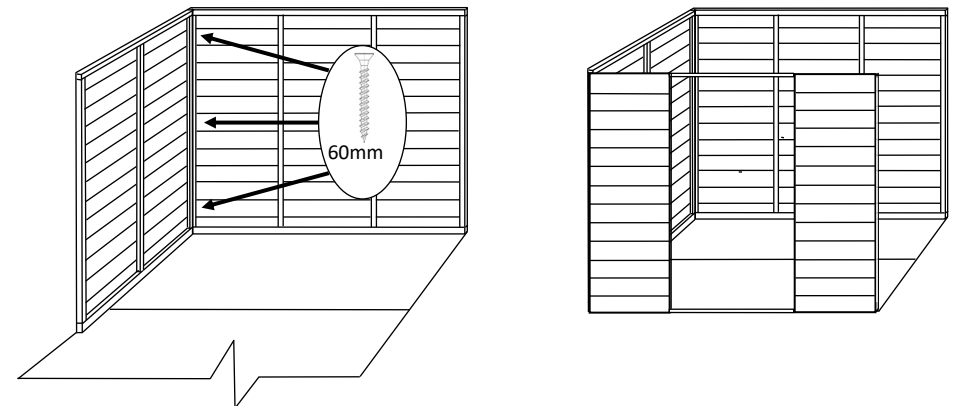

### Step 3.

Fix the remaining panels in place using the method shown in step 2.

**Do not screw any of the panels to the floor at this point.**

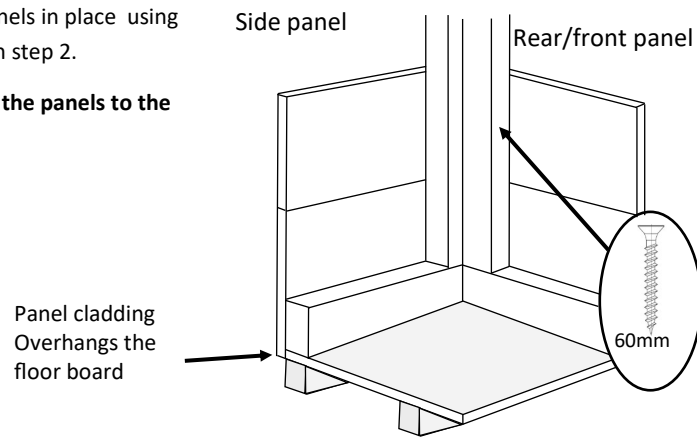

### Step 4.

Fix the Apex points to the top of the front and rear panels using 60mm screws as shown.

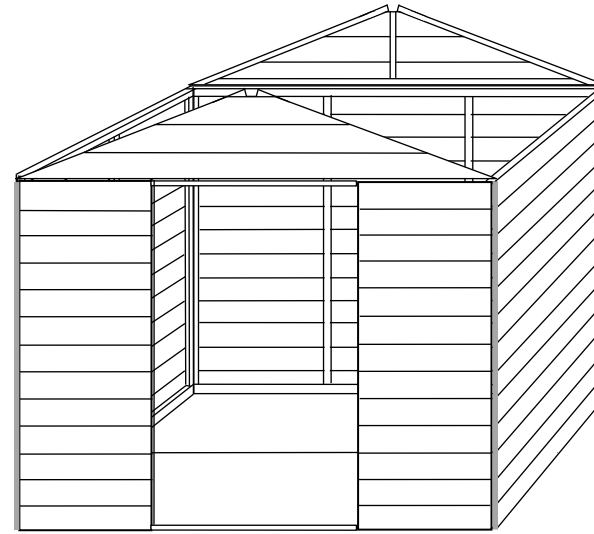
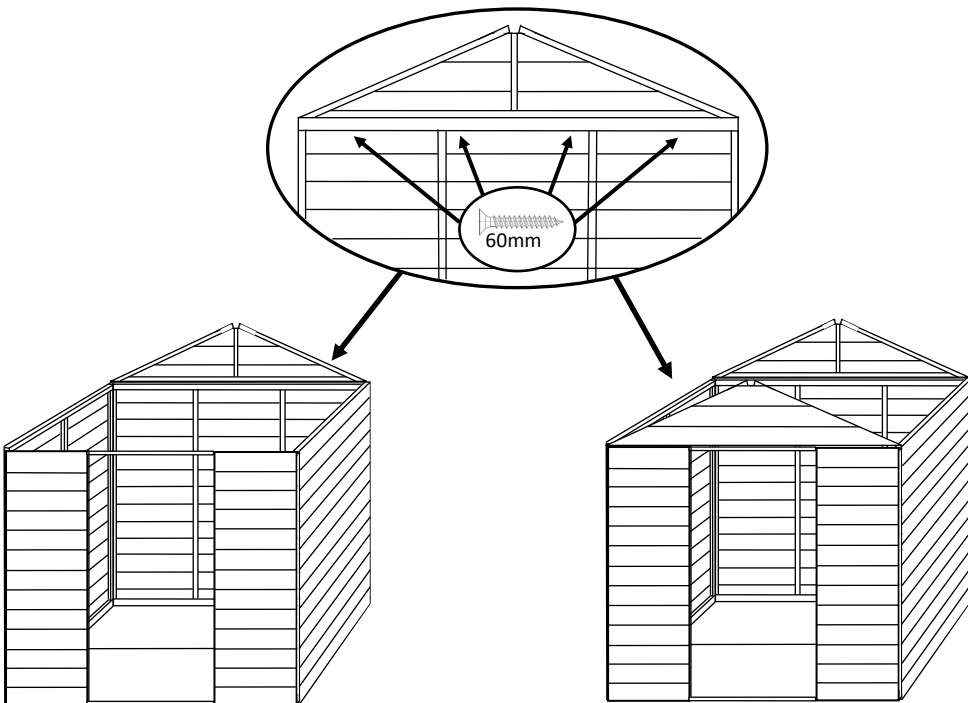

### Step 4 .

Once the Apex points are screwed into position, attach the 6 cover strips, as shown, using 32mm nails.

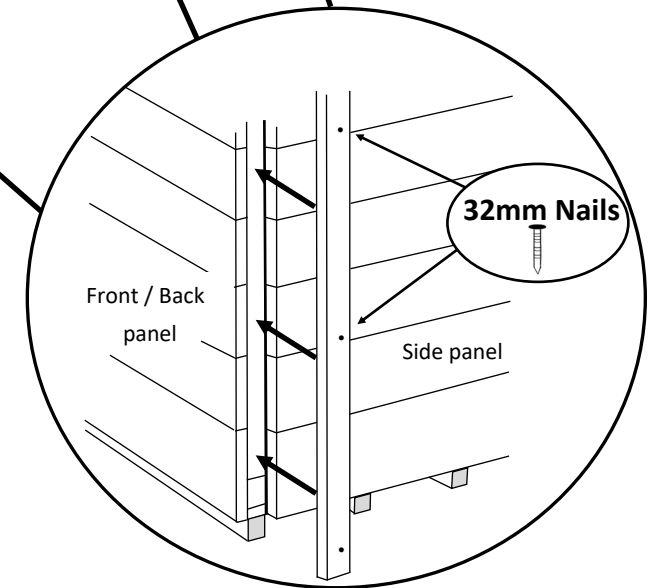

### 3. Roof

#### Step 1.

Lay two of the large roof boards onto the shed as shown. The edges without baton attached should overhang the apex end panel of the shed. Using the 40mm screws, fix the roof brace into position by screwing through the brace into the baton of the roof, ensuring that the roof boards are pushed upwards to match the angle of the roof brace.

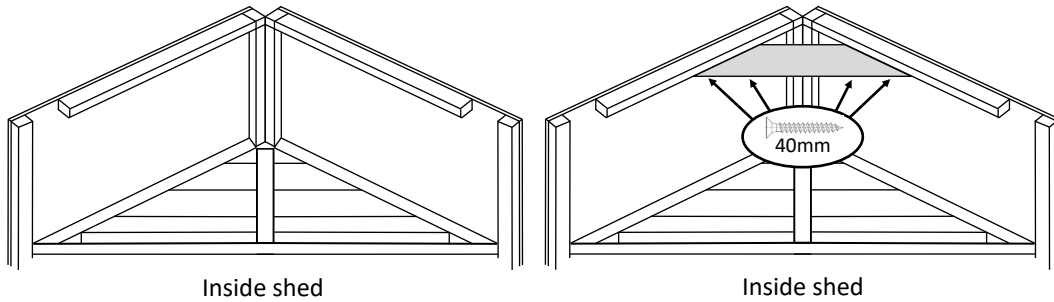

#### Step 2.

Place the next two roof boards onto the shed in the same manner. Secure all roof boards together as shown

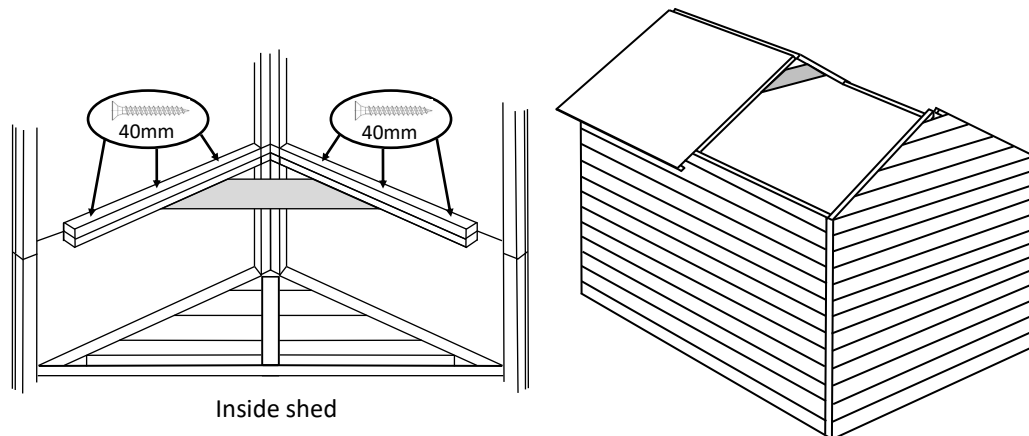

### 4. Felt

#### Step 1.

Position the first length of felt along the lower edge of one side of the roof and fix as shown. Repeat on the other side of the shed. Place the next piece of the felt over the apex of the roof, ensuring that it overlaps the lower piece by at least 10cm and fix with 13mm clout nails as shown. Finally attach the last piece of felt in the same way.

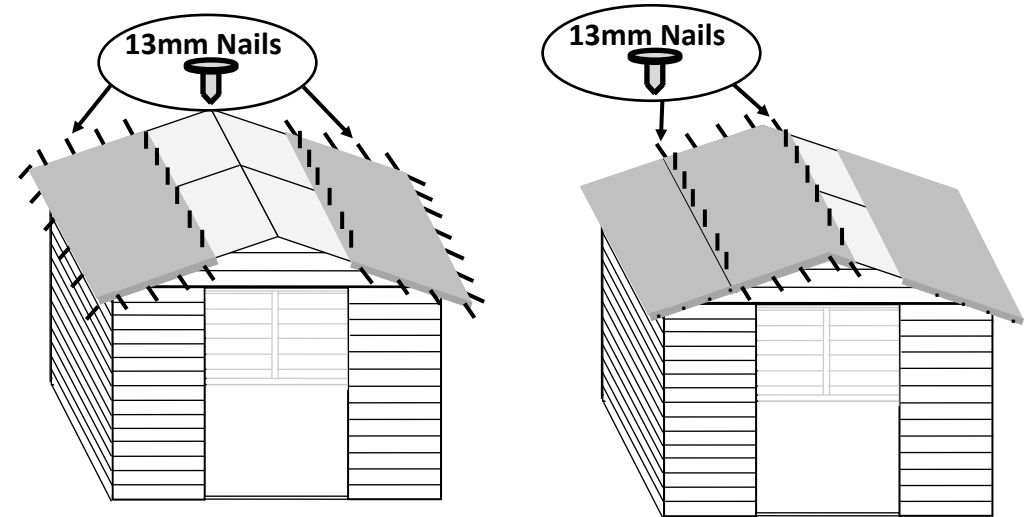

#### Step 2.

Attach the barge boards to the front and back of the roof with the 32mm nails. Ensure that each barge board is flush with the roof line before fixing. Next place the diamond over the join between the barge boards and fix in place with the 32mm nails.

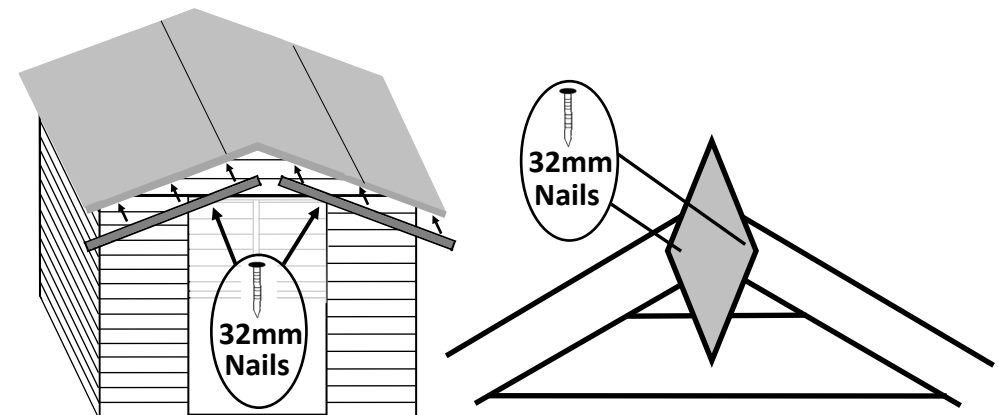

## 5. Doors

Lie the door on a flat surface with the cladding facing upwards. Take one T hinge and position on the door as shown below, making sure that the T hinge is directly above the brace on the underside of the door. Fix the T hinge into place with the 25mm black screws. Repeat for the remaining T hinges. With the T hinges secured, position the door squarely in the door frame. Fix the top hinge first with 1 screw and the bottom hinge second with the 25mm black screws. Make sure that the door can open and close freely and then fix the remaining screws into the hinges

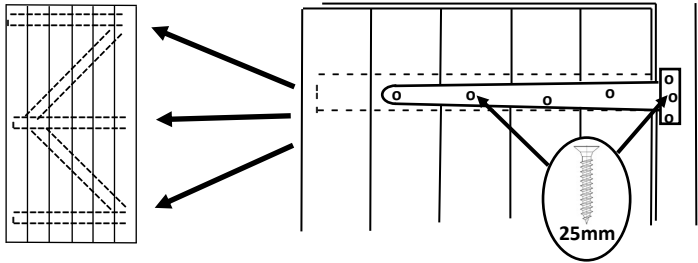

## 6. Hasp and Staple

Attach the hasp and staple to the outside of the door and door frame, using the black 25mm screws, as shown below.

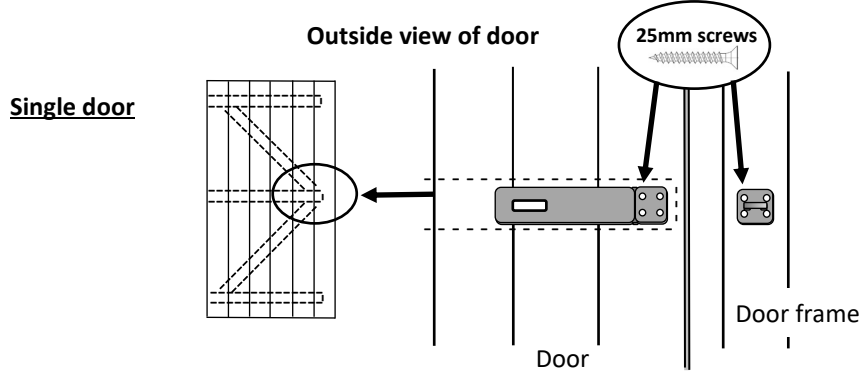

## Double door

If your shed has a double door, see opposite. Using a hand saw, you will need to cut out a small section of the weather strip on the door over the middle brace, to allow fitting of the hasp and staple.

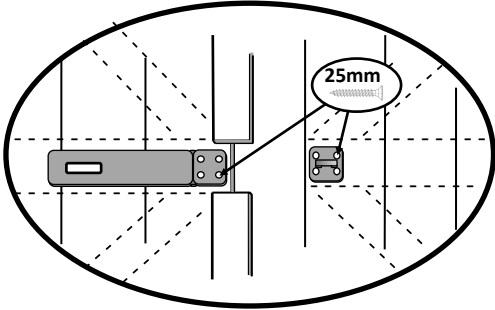

## 7. Windows (optional)

To fit the windows it is recommended that a waterproof sealant is applied around the edge of the glazing before fitting. From the inside of the building fit the styrene window into the frame and secure in place with the 4 strips of window bead. Fix the window bead to the window frame with 30mm panel pins .

