

---

## ASSEMBLY INSTRUCTION

# BAR CHAIR

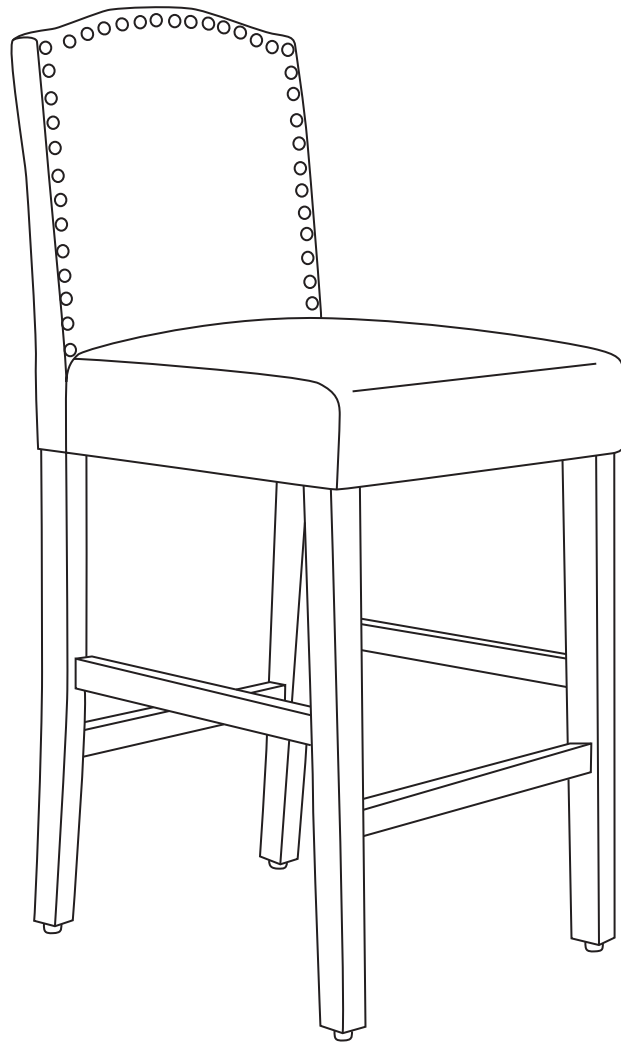

---





Please carefully unpack and identify each component before beginning assembly. Before you begin, please refer to parts list to make sure that you have all parts. Please take care when assembling the unit and always place the parts on a clean, soft surface. If you require assistance with assembly or parts, [REDACTED]

---



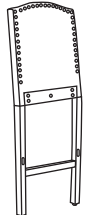

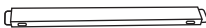
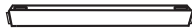

# PRE-ASSEMBLY PREPARATION

- **CAUTION:** Assembly will require at least 2 adults. DO NOT use power tools. Please inspect all items BEFORE assembly. If for any reason you need to return this item, please kindly return it in its original packaging.
- **WARNING!**
  1. DO NOT let any sharp objects touch or rub the surface of the product.
  2. When assembling, do not let children play around the working area.
  3. DO NOT tighten all bolts and screws completely until the entire unit has been assembled and set up.
  4. DO NOT USE if this product become damaged, and/or components are broken or missing.
- **CARE AND CLEANING:** DO NOT scratch or chip the finish. DO NOT use abrasive chemicals for cleaning. Clean with mild soap on a soft rag. Rinse and dry thoroughly.
- **MAINTENANCE:** Please periodically check all fittings and re-tighten as necessary.

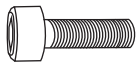
## PARTS LIST

<p>BACK (A)</p>  <p>Qty: 2</p>	<p>SEAT (B)</p>  <p>Qty: 2</p>	<p>LEFT RUNG (C-L)</p>  <p>Qty: 2</p>	<p>RIGHT RUNG (C-R)</p>  <p>Qty: 2</p>
<p>FRONT RUNG (D)</p>  <p>Qty: 2</p>	<p>LEFT FRONT LEG (L)</p>  <p>Qty: 2</p>	<p>RIGHT FRONT LEG (R)</p>  <p>Qty: 2</p>	

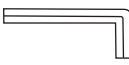
## HARDWARE LIST

<p>ALLEN BOLT (1) M8X60MM</p>  <p>Qty: 10</p>	<p>ALLEN BOLT (2) M8X80MM</p>  <p>Qty: 8</p>	<p>SPRING WAAHER (3)</p>  <p>Qty: 18</p>	<p>FLAT WASHER (4)</p>  <p>Qty: 18</p>
<p>ALLEN KEY (5)</p>  <p>Qty: 2</p>	<p>SCREW (6) M4X50MM</p>  <p>Qty: 12</p>		

## STEP-BY-STEP ASSEMBLY

PLEASE CAREFULLY UNPACK AND IDENTIFY EACH COMPONENT BEFORE BEGINNING ASSEMBLY. BEFORE YOU BEGIN, PLEASE REFER TO PARTS LIST TO MAKE SURE THAT YOU HAVE ALL PARTS.

- STEP 1** Attach the Seat (B) to the Back (A) by using Flat Washer (4), Spring Washer (3), Allen Bolt (1), Allen Bolt (2) and Allen Key (5) as shown in below diagram.  
Please tighten the bolts 80%.

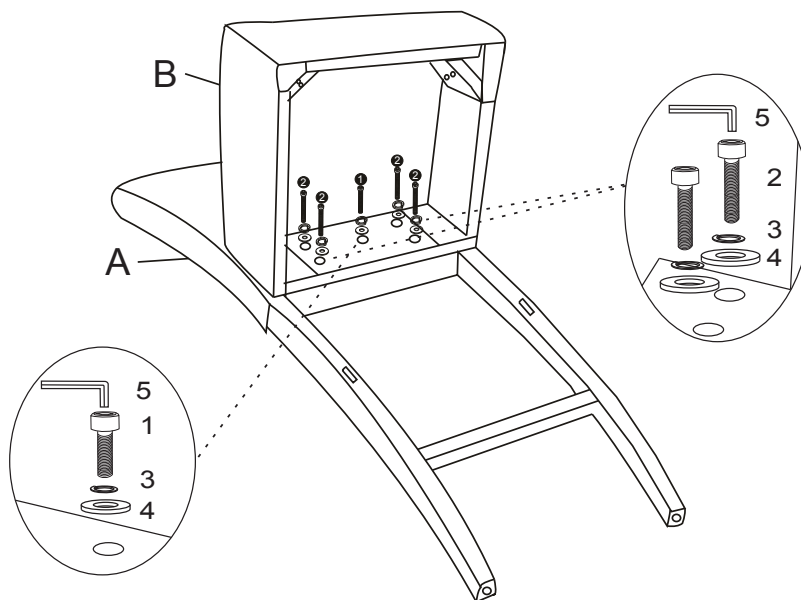

- STEP 2** Please put the Left Rung (C-L) and the Right Rung (C-R) into the chair Back (A) as shown in below diagram.

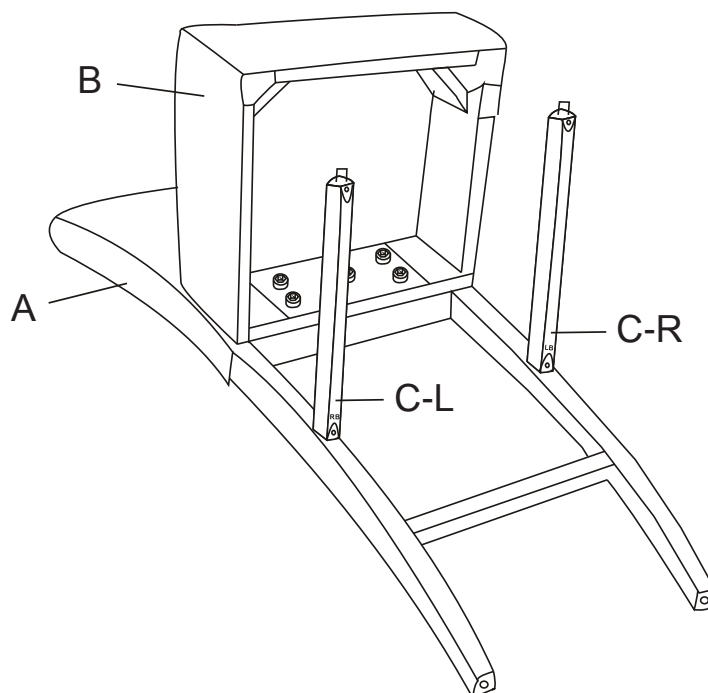

**STEP 3** Please put two Front Legs (L&R) into the Seat (B), and then put Front Rung (D) into the Front Legs(L&R) as shown in below diagram.

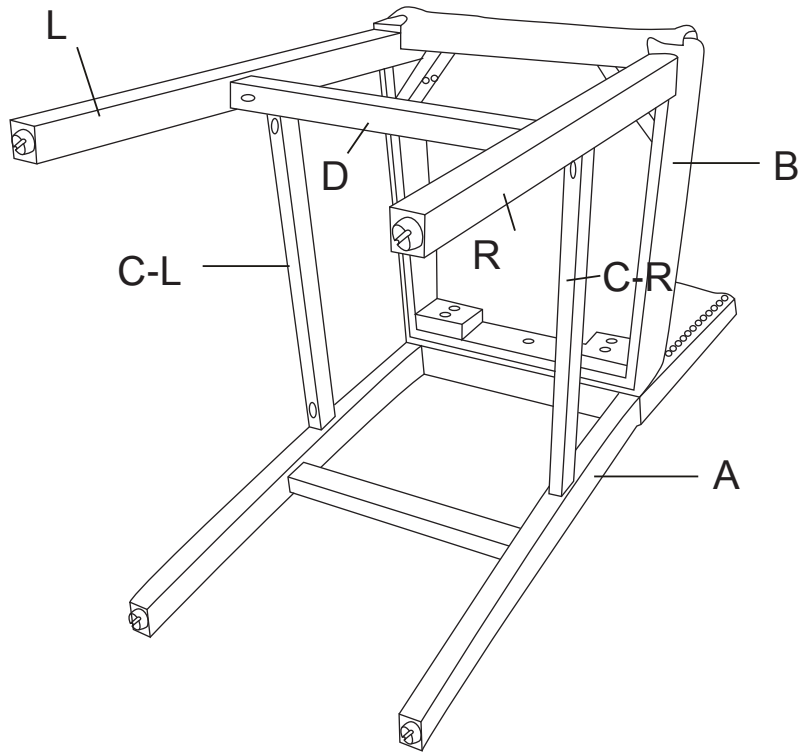

**STEP 4** Attach two Front Leg (L&R) to the Seat (B) by using Flat Washer (4), Spring Washer (3), Allen Bolt (1) and Allen Key (5) as shown in below diagram. Please tighten the bolts 80%.

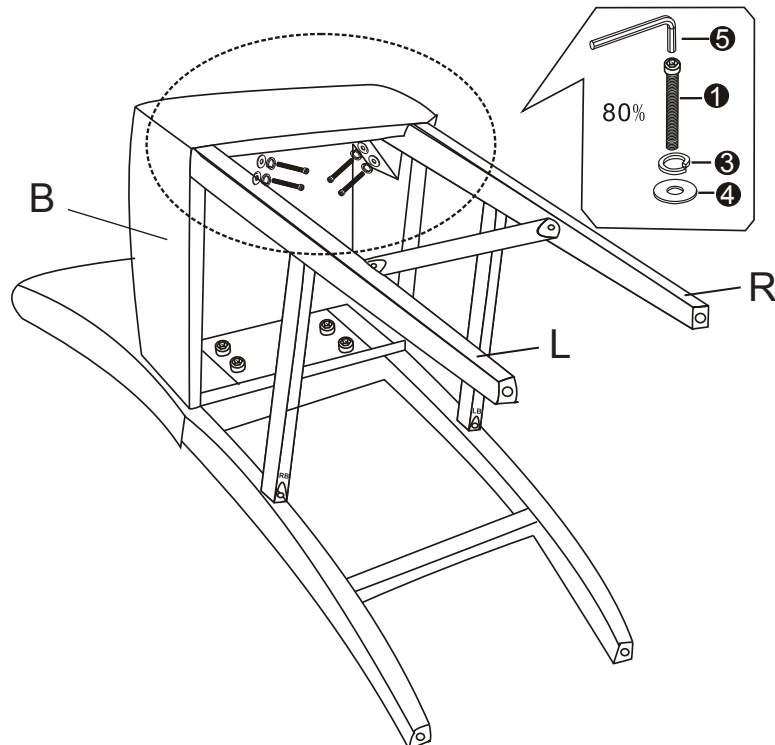

**STEP 5** Insert the screw (6) into the holes on the Rungs (D&L&R) by screwing it in as shown in below diagram. Please tighten the all screws 100%.

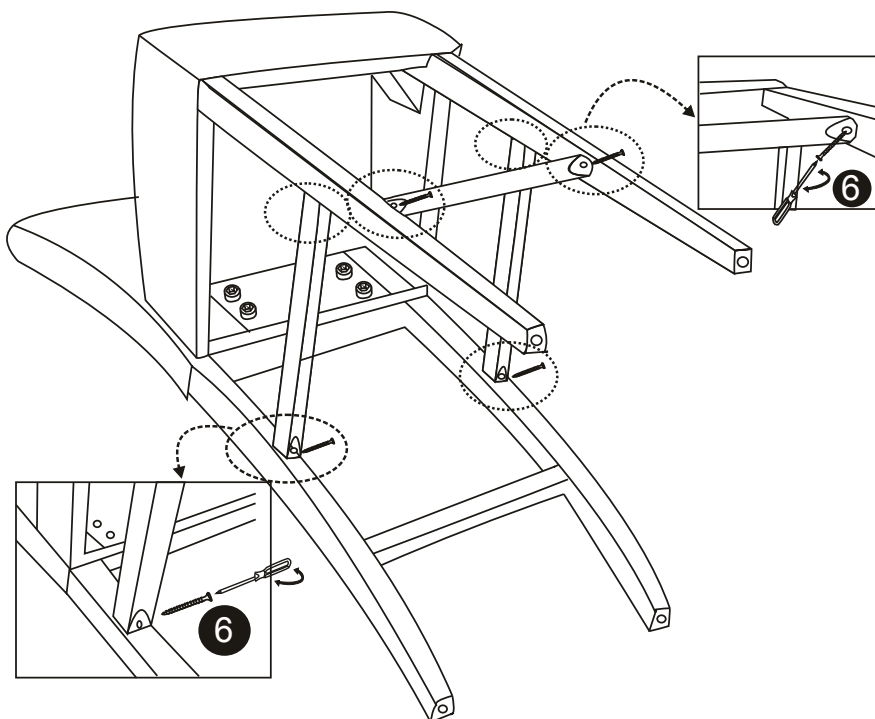

**STEP 6** Use body weight to adjust balance of chair, then please tighten all the bolts (1&2) 100%.

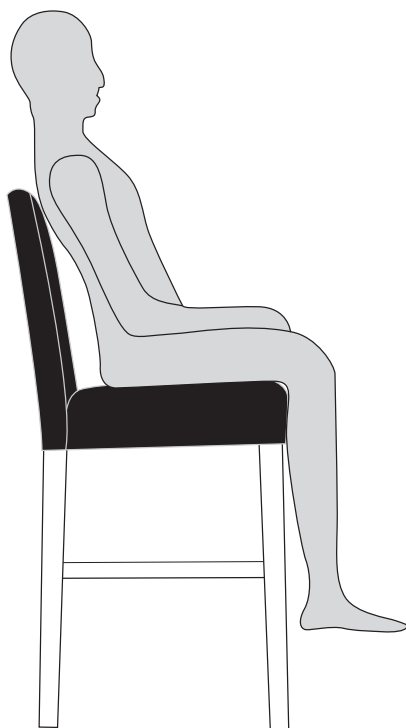

**STEP 7** Use Adjusting leveler to adjust the level of chair if necessary.

