

# *ASSEMBLY INSTRUCTIONS*



*29"*  
**BAR STOOL**

# ASSEMBLY INSTRUCTIONS

## ASSEMBLY TIPS:

1. Remove hardware from box and sort by size.
2. Please check to see that all hardware and parts are present prior to start of assembly.
3. Please follow attached instructions in the same sequence as numbered to assure fast & easy assembly.



## WARNING!

1. Don't attempt to repair or modify parts that are broken or defective. Please contact the store immediately.
2. This product is for home use only and not intended for commercial establishments.





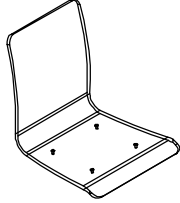
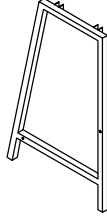
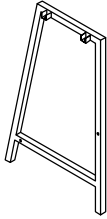
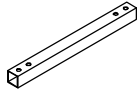
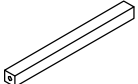



ASSEMBLY TIME 20 MINUTES

## PARTS IDENTIFICATION

A	SEAT AND BACK		1PC
B	LEFT FRAME		1PC
C	RIGHT FRAME		1PC
D	TOP CROSSBAR		2PCS
E	BOTTOM CROSSBAR		2PCS

Z

HARDWARE IDENTIFICATION

1	SHORT BOLT (1/4" x 12mm SR)		4PCS
2	LONG BOLT (1/4" x 35mm SR)		4PCS
3	WASHER (ø16mm)		8PCS
4	PLASTIC WASHER (ø16mm)		4PCS
5	SPRING WASHER (1/4")		8PCS
6	NUT (1/4")		4PCS
7	CAP (25 x 25mm BLK)		4PCS
8	HEX CAP HEAD BOLT (1/4" x 27mm)		4PCS
9	ALLEN WRENCH (4mm)		1PC

NOTE:QUANTITIES SHOWN ARE FOR ONE STOOL

# ASSEMBLY INSTRUCTIONS

**STEP 1** Do not tighten until each step is completed or instructed.

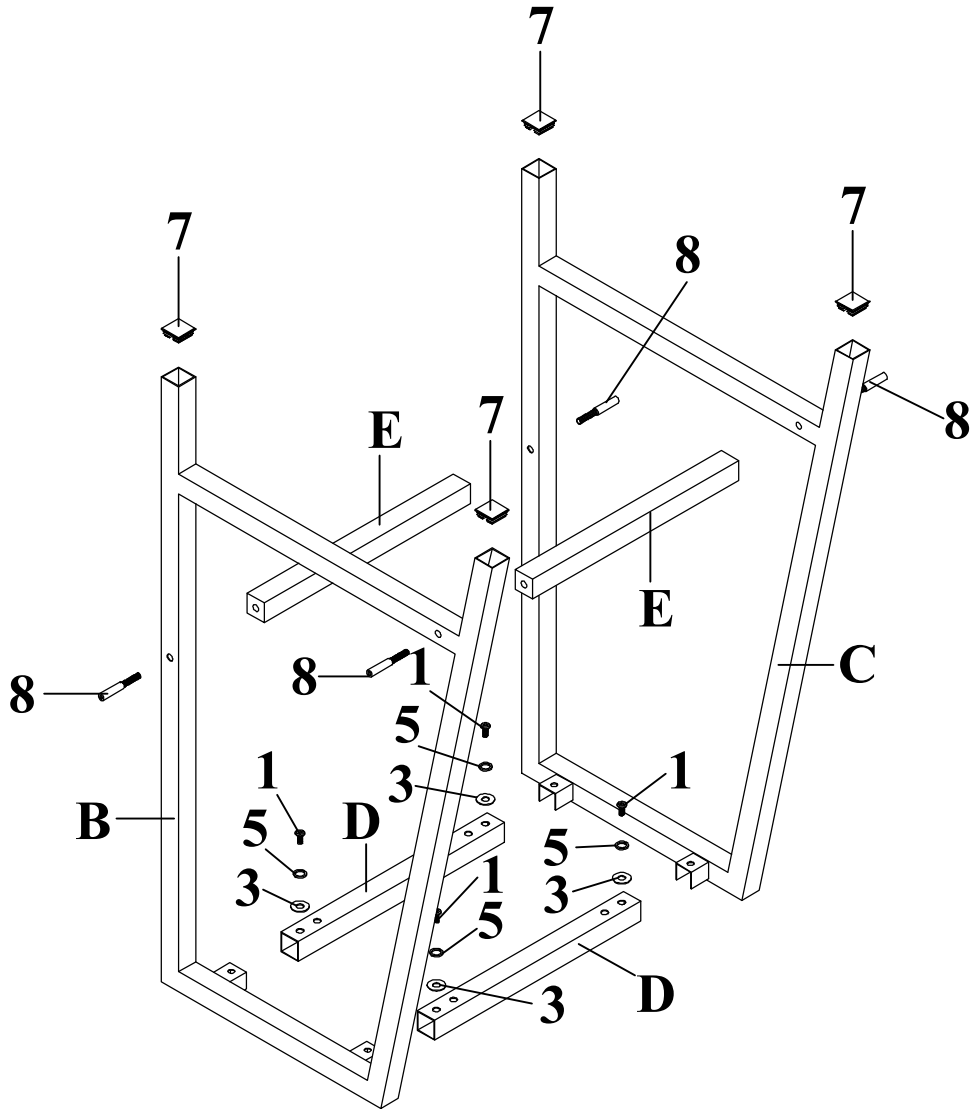

# ASSEMBLY INSTRUCTIONS

## STEP 2

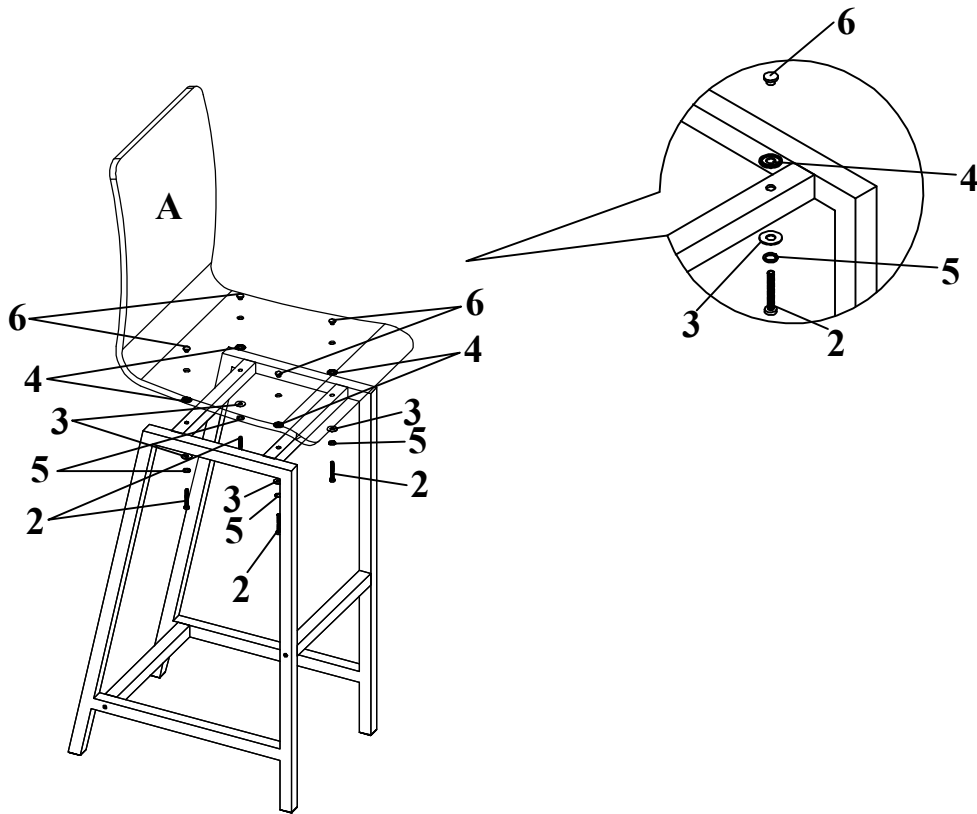

## STEP 3

## COMPLETE

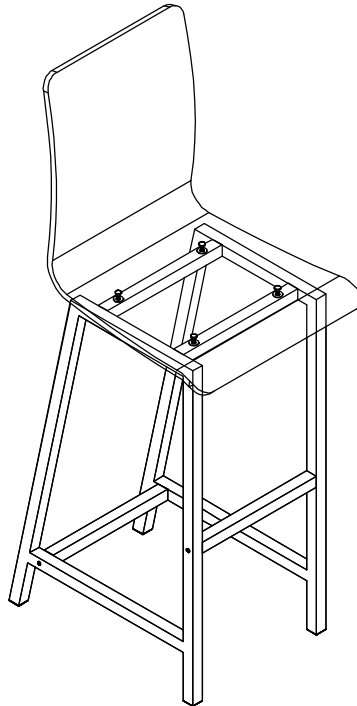

How to clean Acrylic product:

Using a dry soft microfiber cloth, lightly brush off any dust.

For additional care, dampen the cloth with warm water.

For deepest cleaning, use an Acrylic cleaner.

# ASSEMBLY INSTRUCTIONS

**Product Size : 432 X 533 X 1168 H (MM)**

**Product Size : 17" X 21" X 46"**

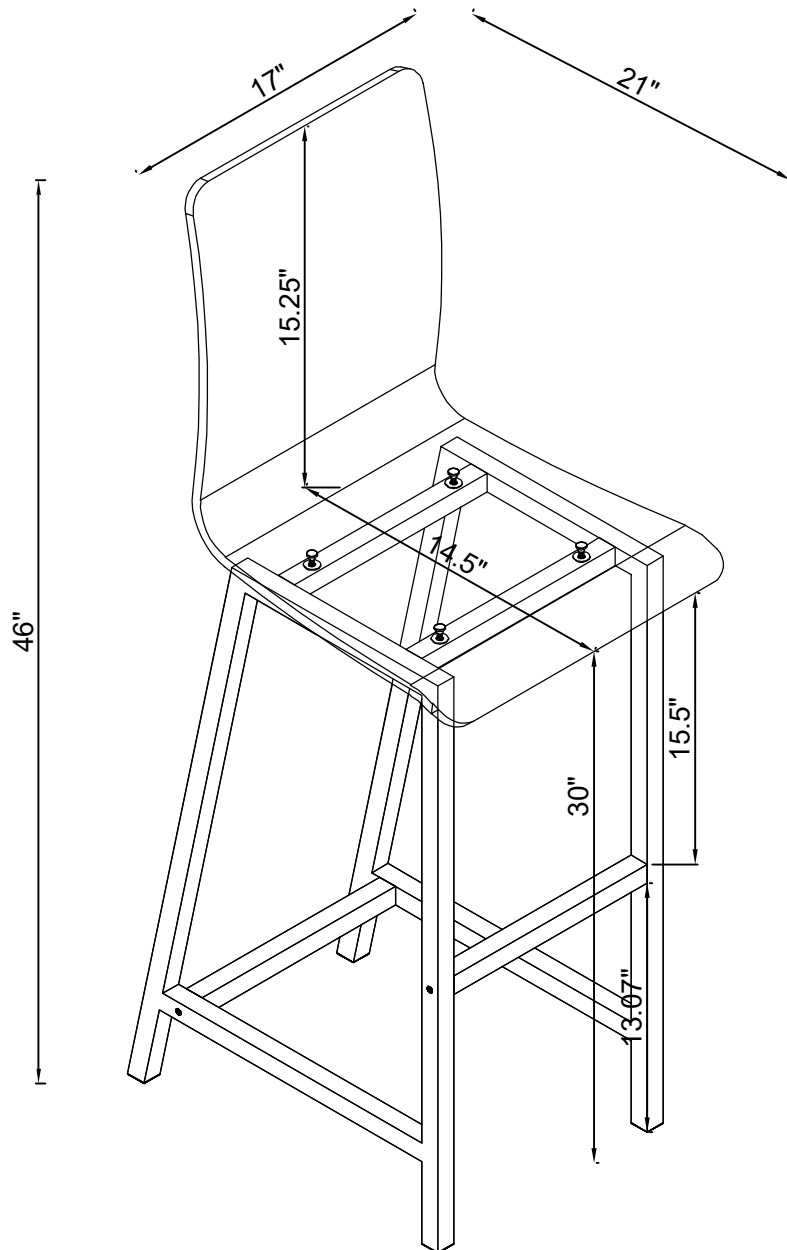

Note : Dimension tolerance  $\pm 5\%$

*ASSEMBLY INSTRUCTIONS*



*BAR  
TABLE*

# ASSEMBLY INSTRUCTIONS

## ASSEMBLY TIPS:

1. Remove hardware from box and sort by size.
2. Please check to see that all hardware and parts are present prior to start of assembly.
3. Please follow attached instructions in the same sequence as numbered to assure fast & easy assembly.



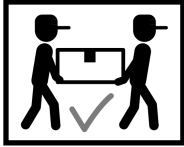

## WARNING!

1. Don't attempt to repair or modify parts that are broken or defective. Please contact the store immediately.
2. This product is for home use only and not intended for commercial establishments.

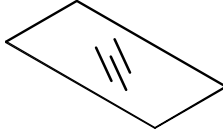
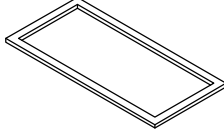
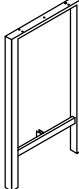
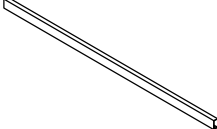

ASSEMBLY TIME 50 MINUTES

## PARTS IDENTIFICATION

A	GLASS		1PC
BN	TOP FRAME		1PC
CN	SIDE FRAME		2PCS
D	CROSSBAR		1PC
E	TRIANGLE METAL		4PCS
F	SUPPORT METAL		4PCS

# ASSEMBLY INSTRUCTIONS

## HARDWARE IDENTIFICATION

ZN

1 SHORT BOLT  
(1/4" x 12mm SR)  12PCS

2 LONG BOLT  
(1/4" x 30mm SR)  10PCS

3 SUCTION CUP  
( $\phi$ 15 x 2.7mm)  6PCS

4 CAP  
(50 x 50mm BLK)  4PCS

5 WASHER  
( $\phi$ 16mm)  2PCS

6 COVER  8PCS

7 ALLEN KEY  
(4mm)  1PC

### STEP 1

Do not tighten until each step is completed or instructed.

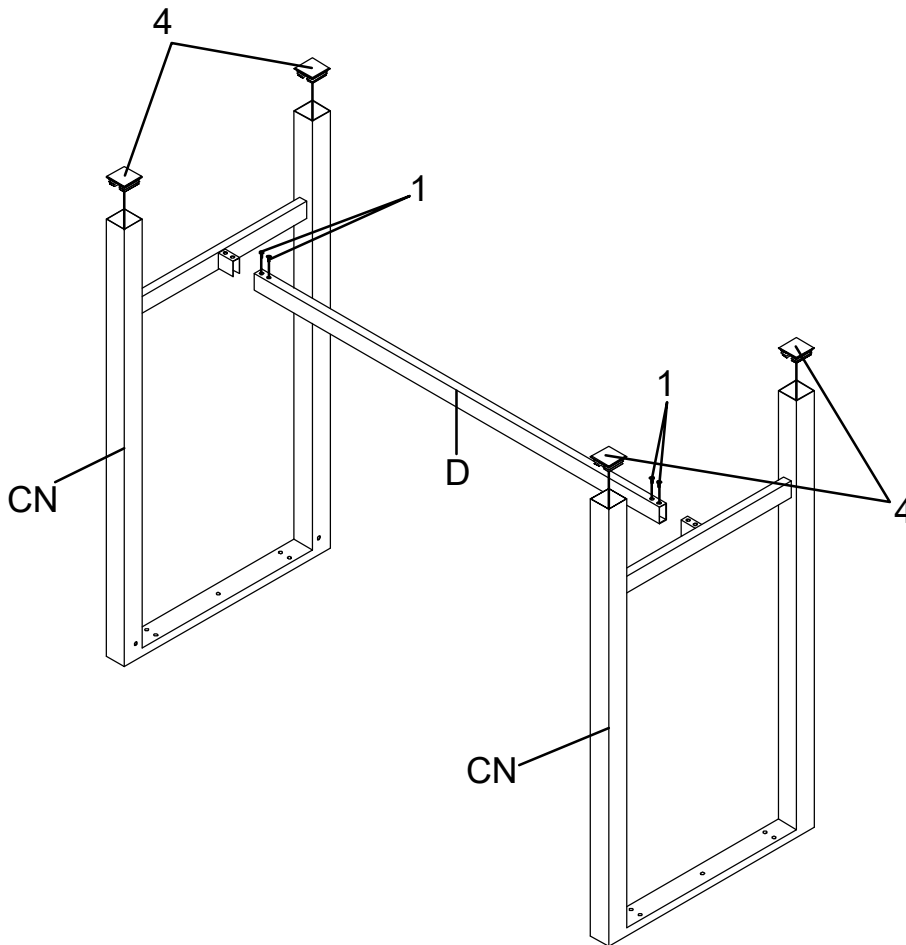

# ASSEMBLY INSTRUCTIONS

## STEP 2

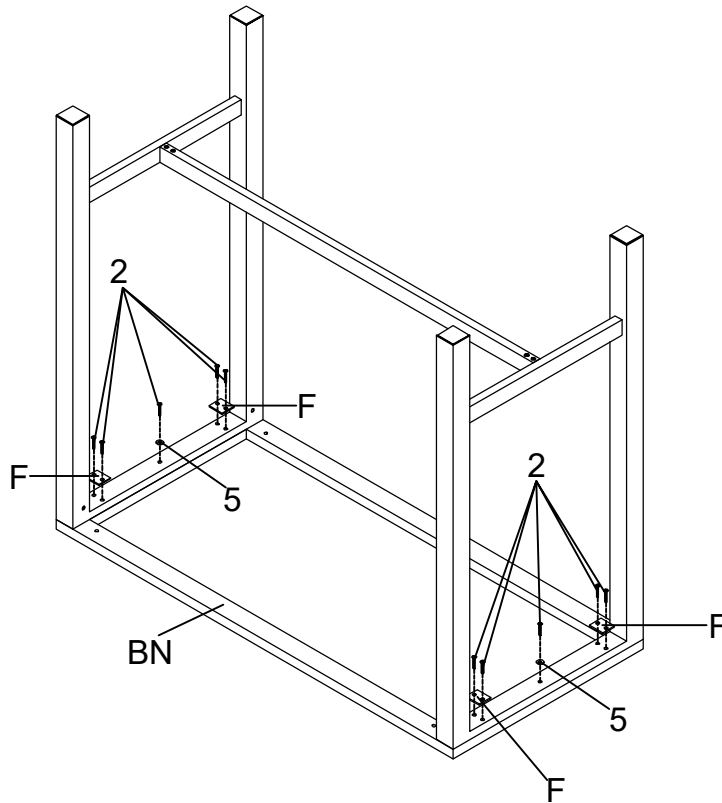

## STEP 3

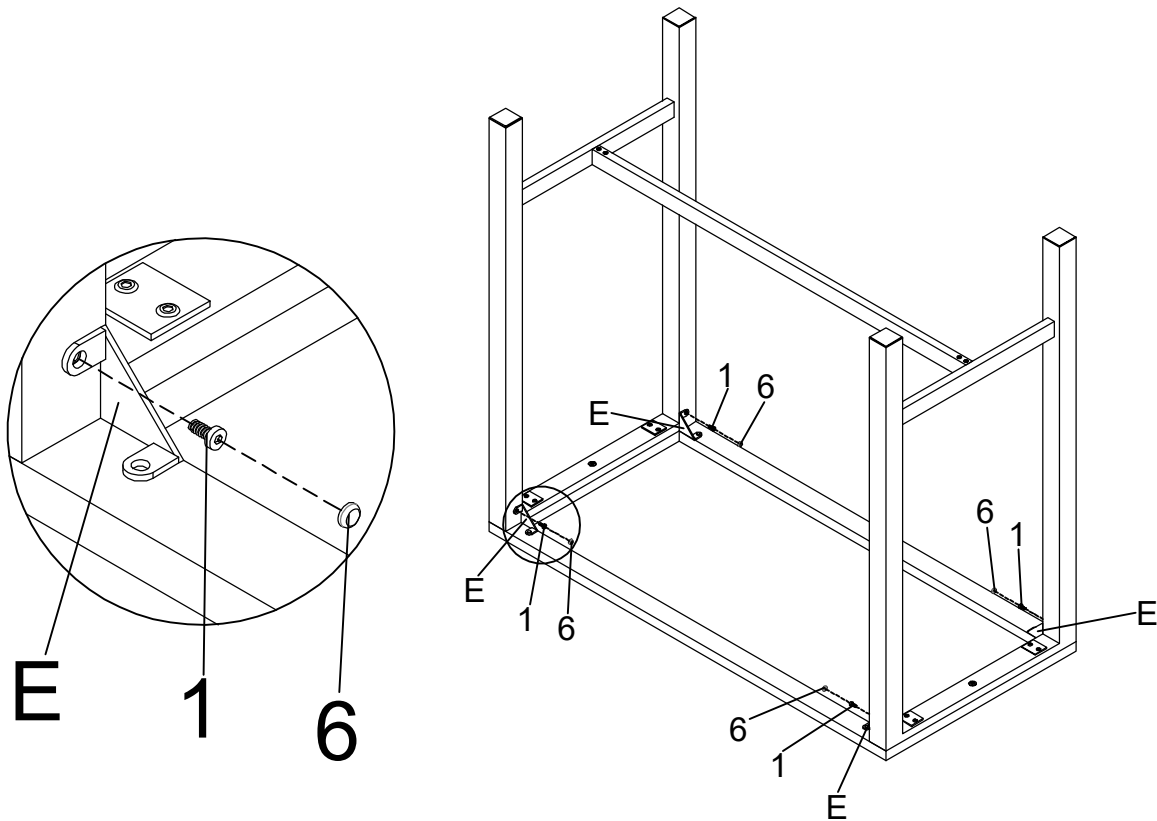

# ASSEMBLY INSTRUCTIONS

## STEP 4

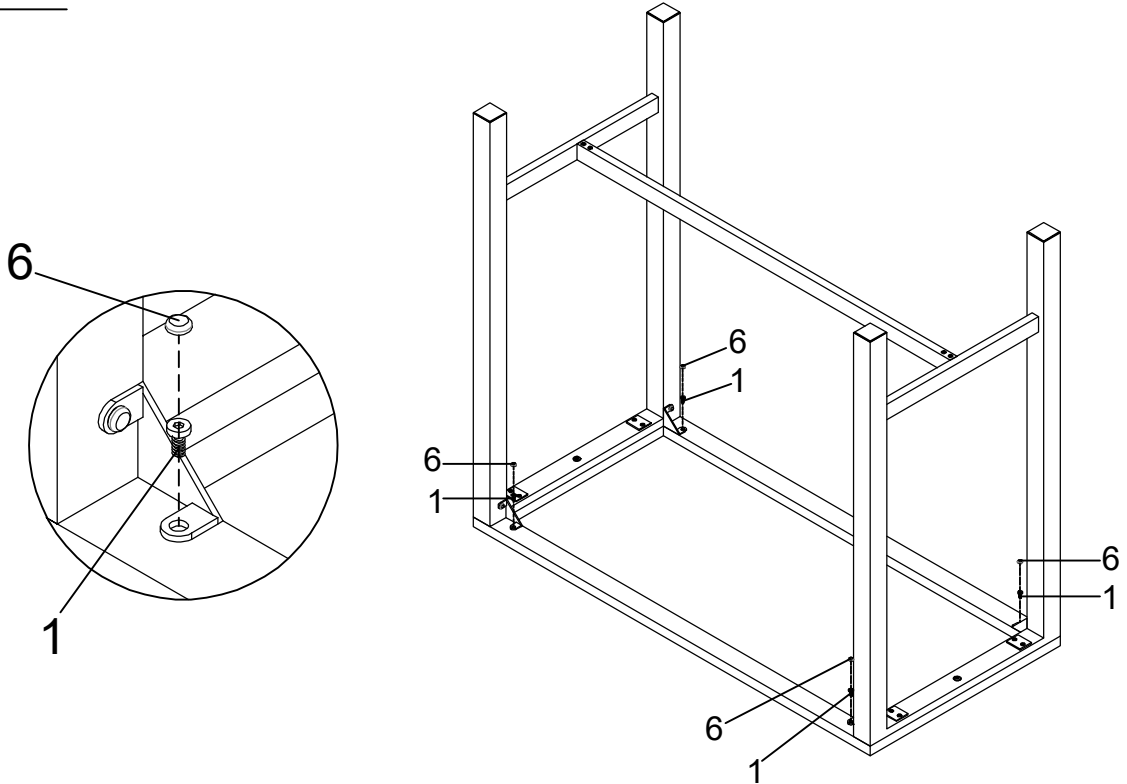

## STEP 5

### COMPLETE

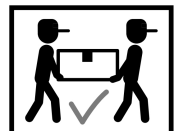
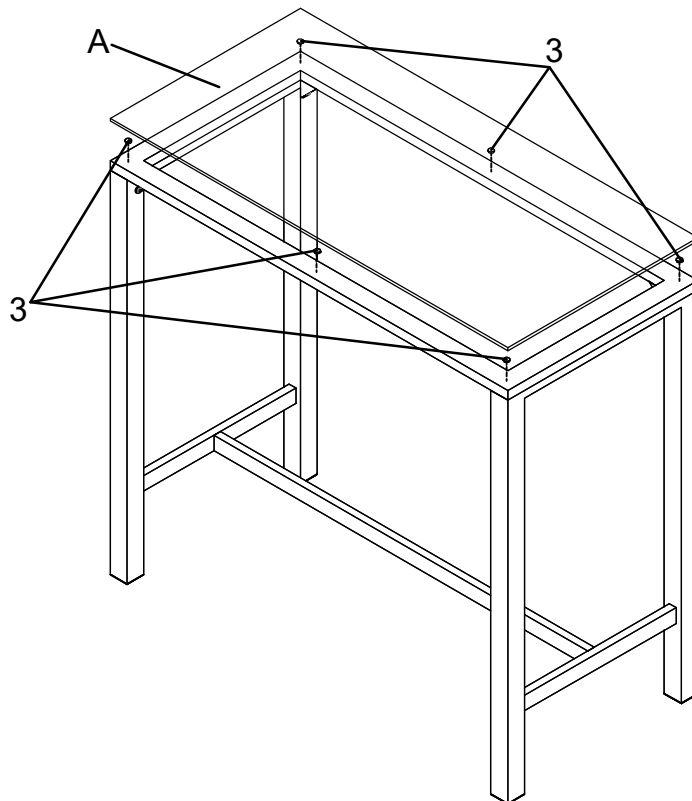

# ASSEMBLY INSTRUCTIONS

**Product Size : 1188 X 571 X 1080 H (MM)**

**Product Size : 46  $\frac{3}{4}$ " X 22  $\frac{1}{2}$ " X 42  $\frac{1}{2}$ "**

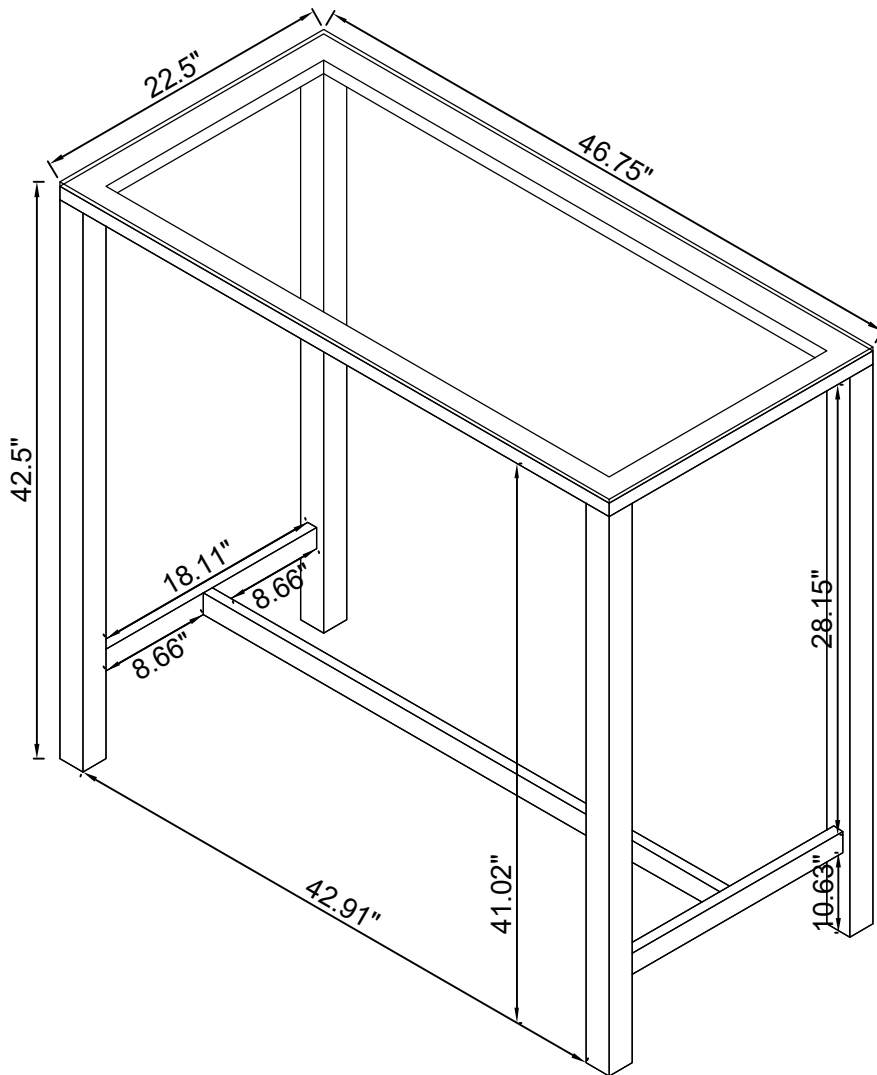

Note : Dimension tolerance  $\pm 5\%$