

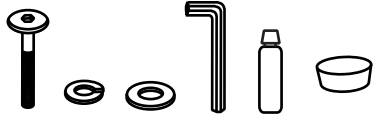

Assembly Instructions





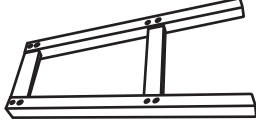
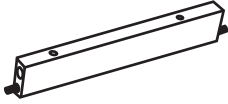
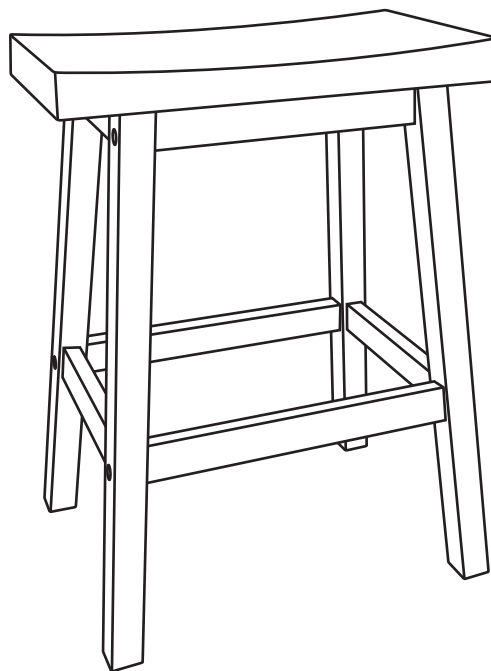

PARTS LIST

FIGURE	DESCRIPTION	QTY
	Hardware Bag	1 Pc
	Hardseat	1 Pc
	Assembly Leg	2 Pcs
	Stretcher	2 Pcs



Assembly Instructions

HARDWARE PARTS :

					
M6x40mm JCBC Bolt 8 pcs	M6x13mm Lock Washer 8 pcs	M6.3x12.5mm Flat Washer 8 pcs	Allen Key 1 pc	Glue 1 pc	Wood Plug 8 pcs

ASSEMBLY

STEP 1

1. Apply **Glue** to all the pre-drilled holes before attaching Stretcher .Insert each Stretcher into pre-drilled holes on both of the Assembly Leg . As shown in Fig.1.
- 1.1 Insert the **JCBC Bolt** through a **Lock Washer** ,a **Flat Washer** and the pre-drilled holes of Assembly Leg into the pre-drilled holes on the Seat Box Rail,use the provided **Allen Key** but do not fully tighten the bolts yet.As shown in Fig.2.
- 1.2 Insert the **JCBC Bolt** through a **Lock Washer** ,a **Flat Washer** and the pre-drilled holes of Assembly Leg into the pre-drilled holes on the Stretcher,use the provided **Allen Key** . As shown in Fig.3.

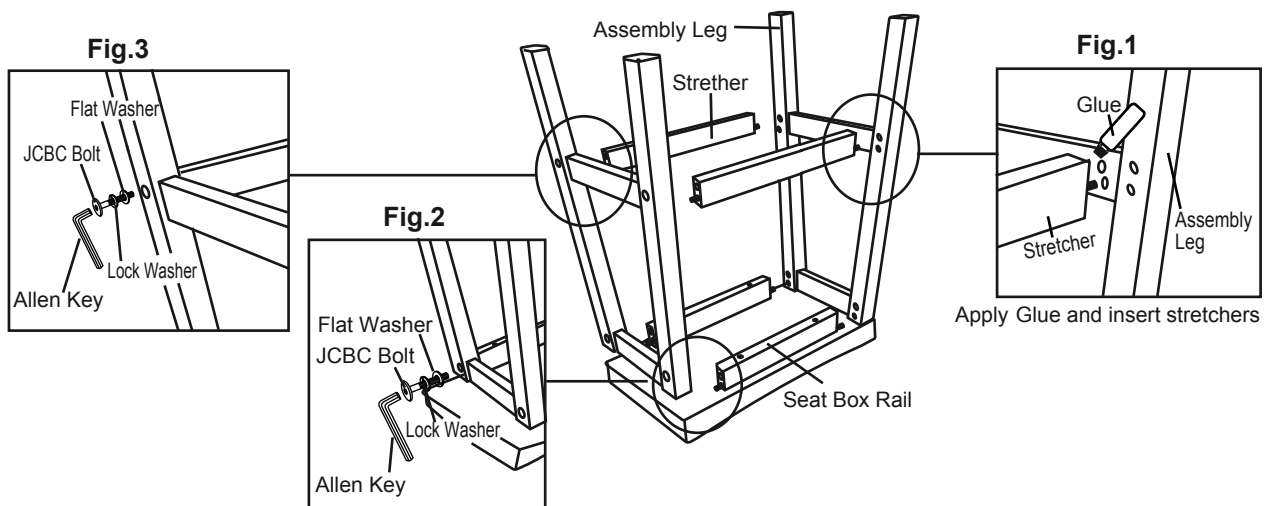

STEP 2

Turn the chair upright . Check it balance and tighten all bolts . Insert **Wood Plug** into the holes at the middle of the Legs.

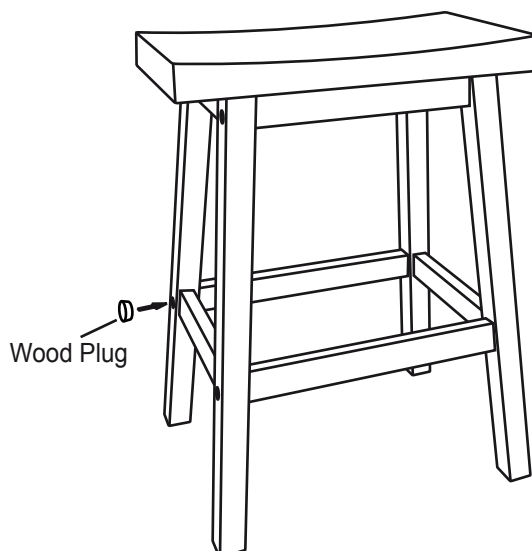

IMPORTANT NOTE :

~ Please keep all hardware out of the reach of children.

CARE INSTRUCTION

~ Be sure to use the same type of polish consistently. Your furniture will appear cloudy or streaky if oil based or wax based polishes are interchanged.
~ Spray your furniture surface evenly. Wipe in a circular motion with a soft clean cloth.