



















Assembly Instruction

A	X20	B	X20	C	X6	D	X20	E	X1	F	X6	G	X6	H	X6
															
M6x35mm		Ø15x9mm		M6x40mm		M3x14mm		4mm		M5x40mm		Ø8x30mm		M6x12mm	
I	X14	J	X2	K	X1	M	X1	N	X8	O	X2	P	X2	Q	X8
															
M7x50mm								M4x35mm		M4x50mm		Ø6x30mm		M3.5x14mm	
S	X4	L	X2	R	X2										
															
M3x16mm															

Cam Lock Fastening System

Insert the cam bolt into the hole first, then insert the cam lock and lock it.

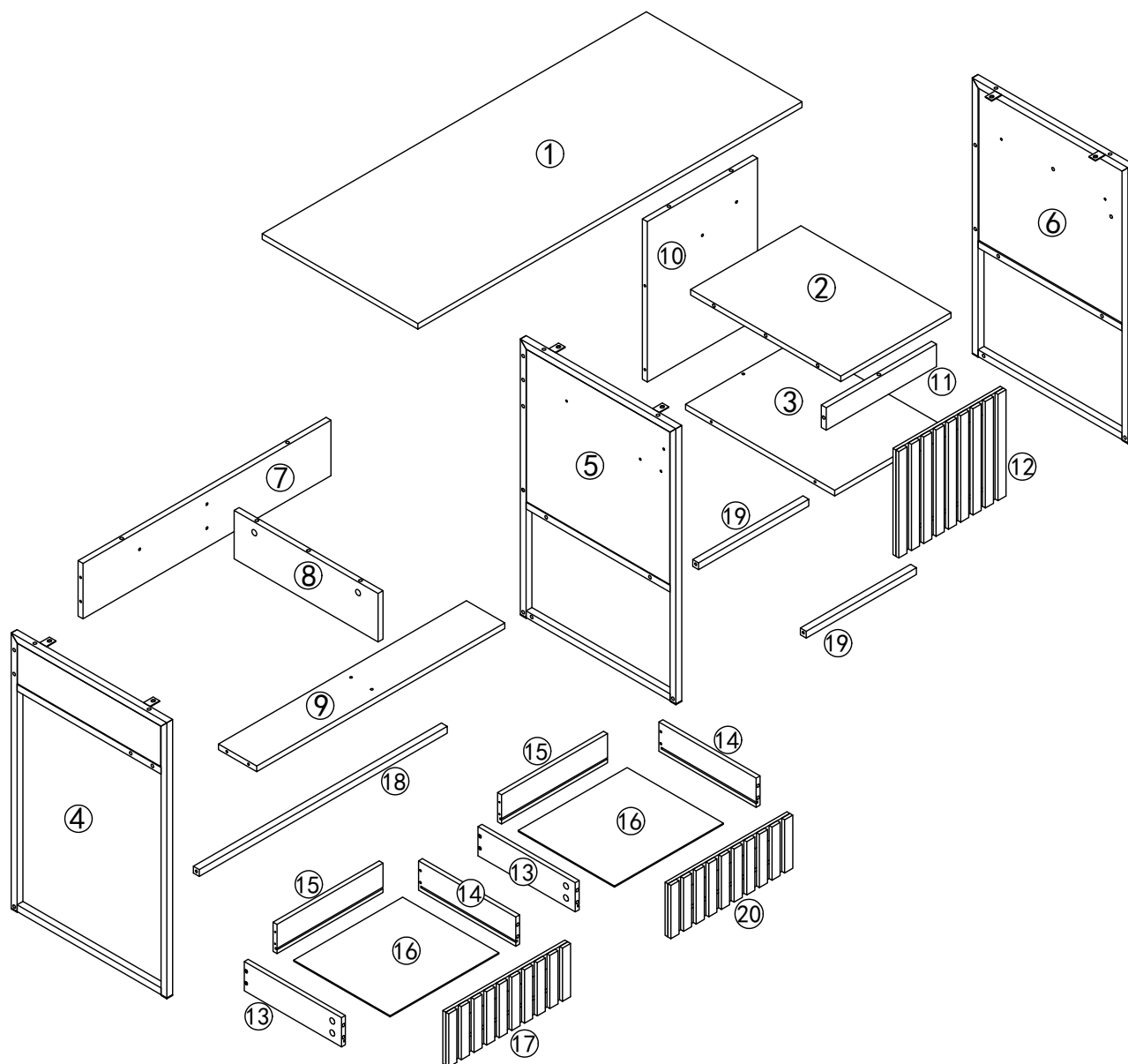
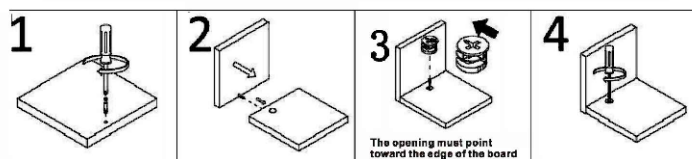

1

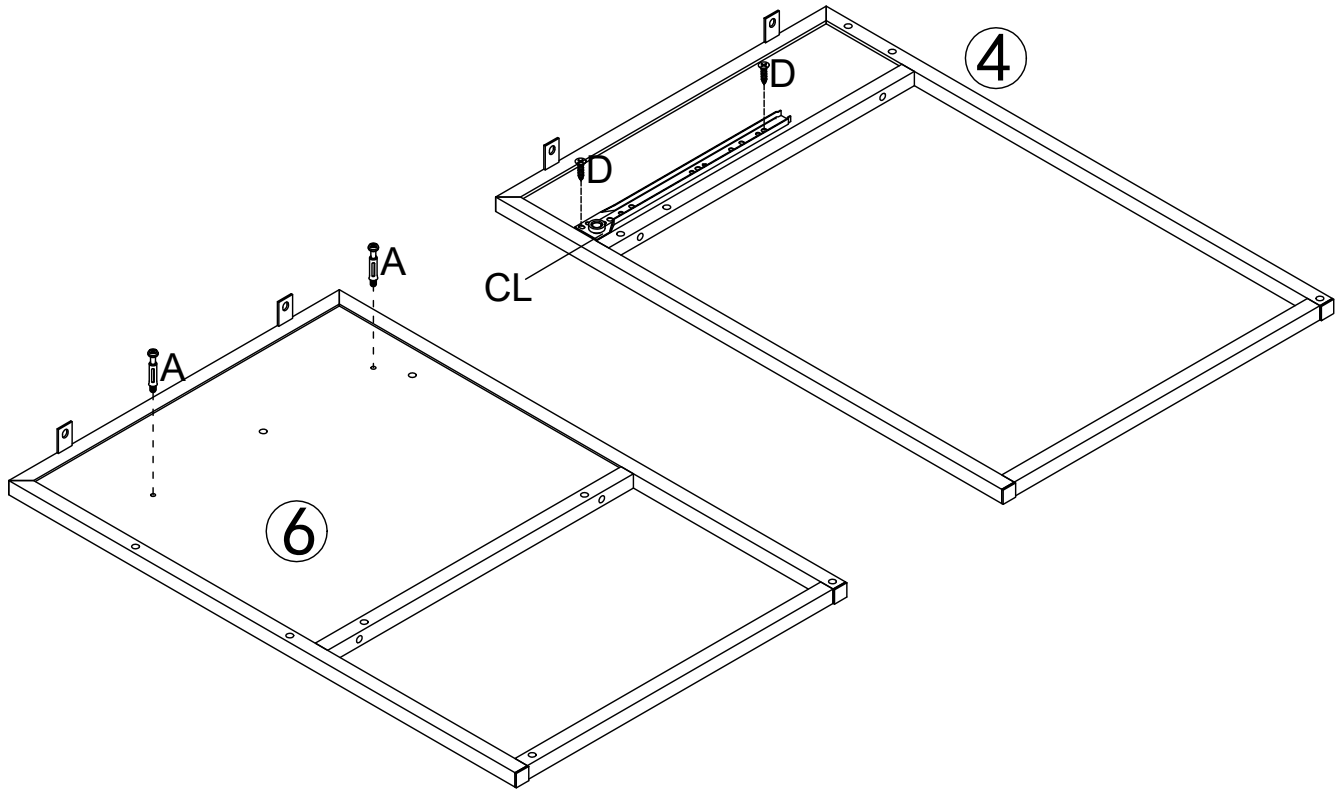
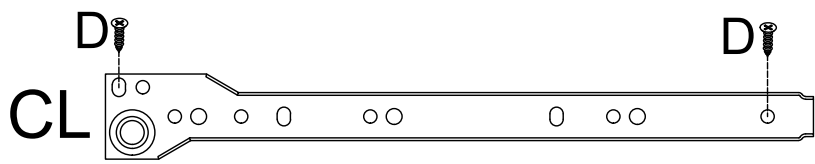

A	x2
	
M6x35mm	

D	x2
	
M3x14mm	

2

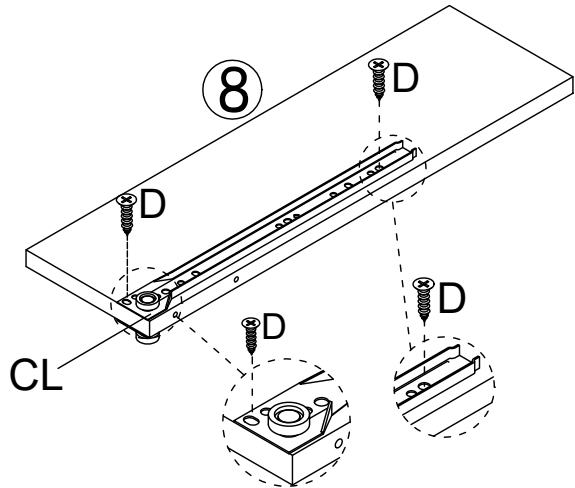
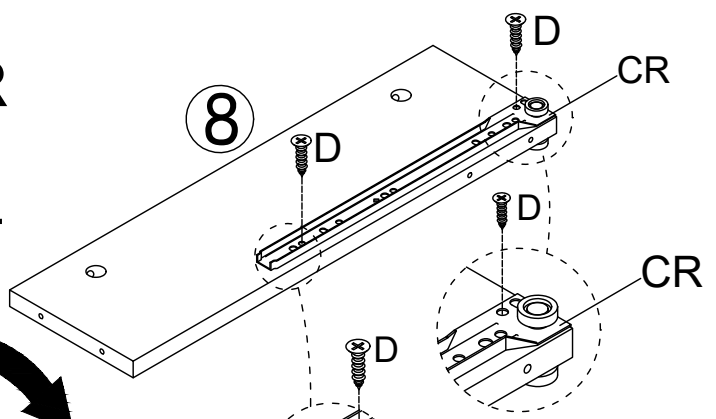
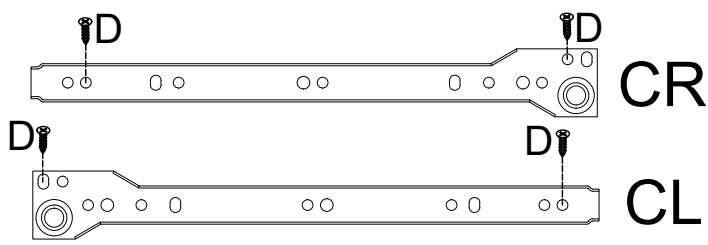

Once done the screws on front side of #8 board, please flip over it to back side to screw slides.

D	x4
	
M3x14mm	

3

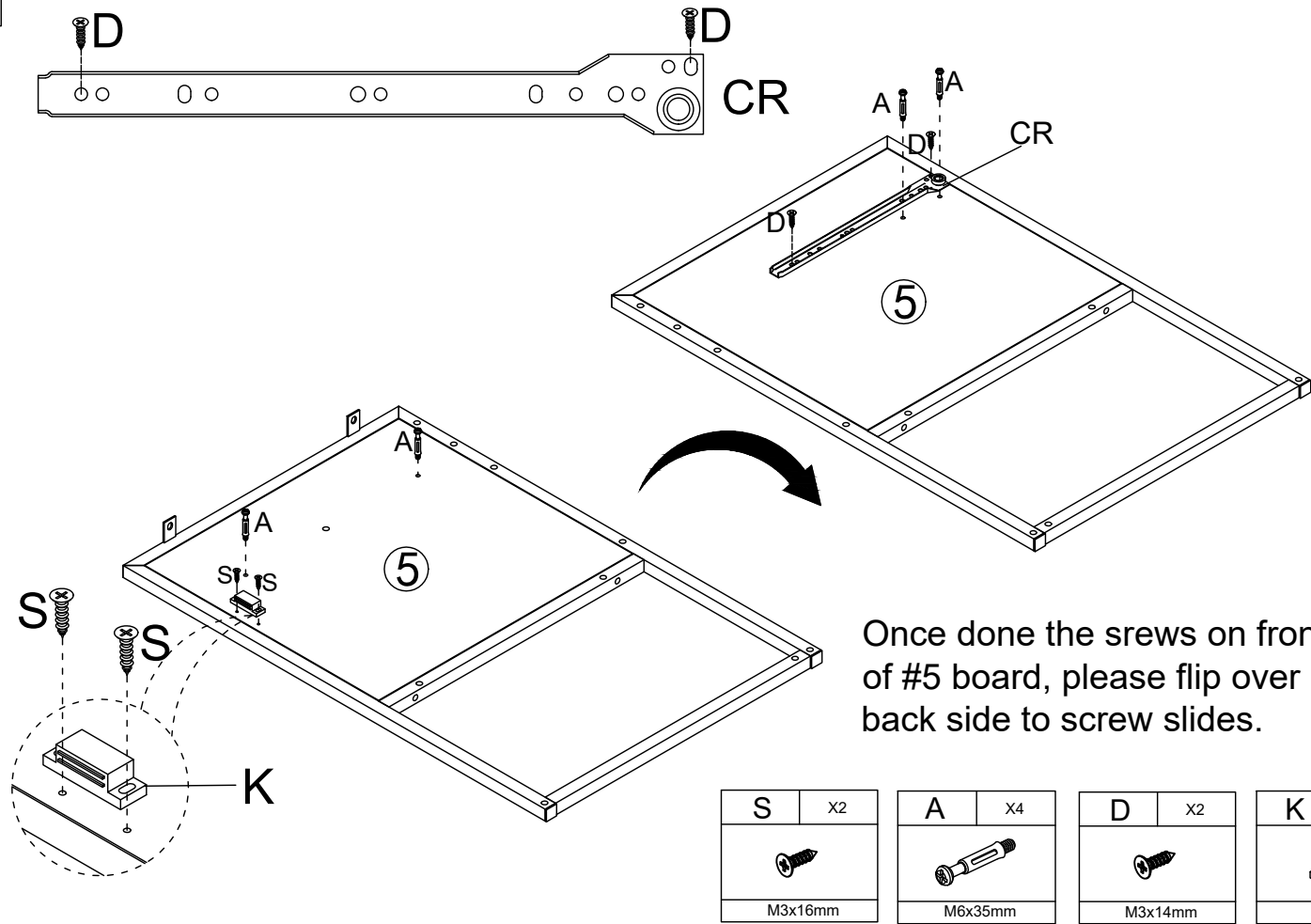

Once done the screws on front side of #5 board, please flip over it to back side to screw slides.

S	X2
	
M3x16mm	

A	X4
	
M6x35mm	

D	X2
	
M3x14mm	

K	X1
	

4

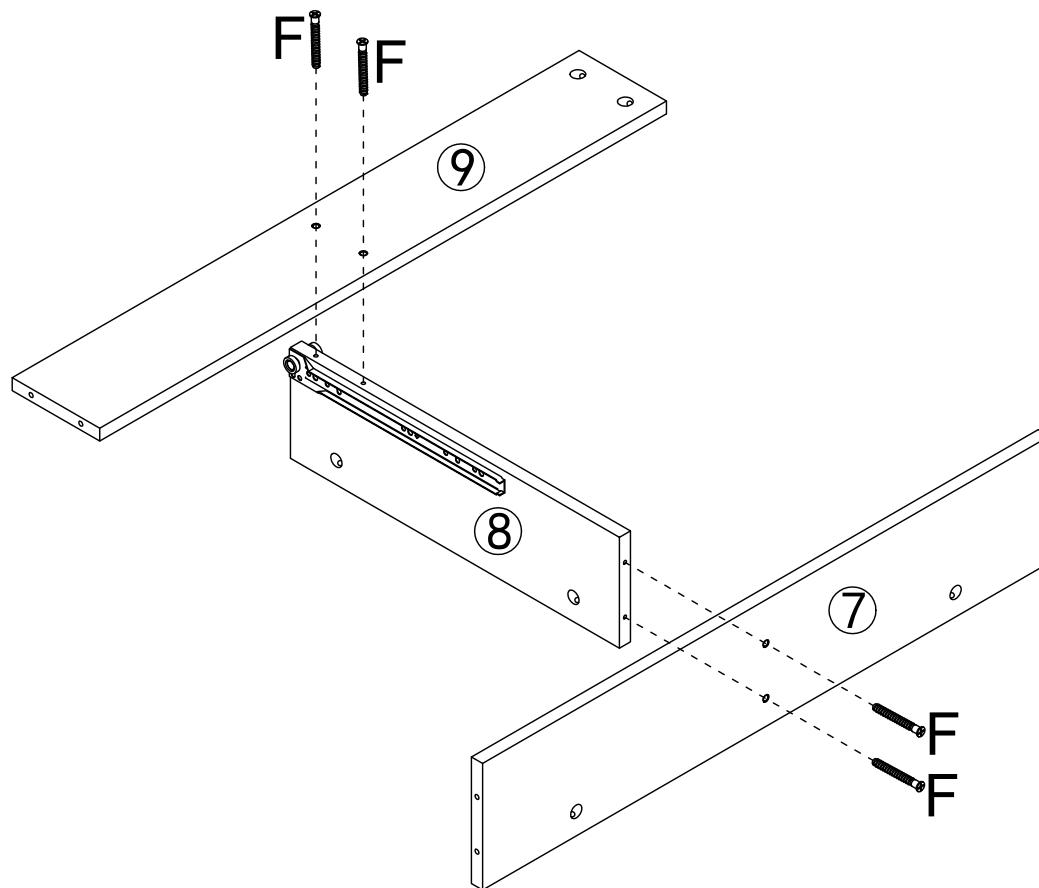

F	X4
	
M5x40mm	

5

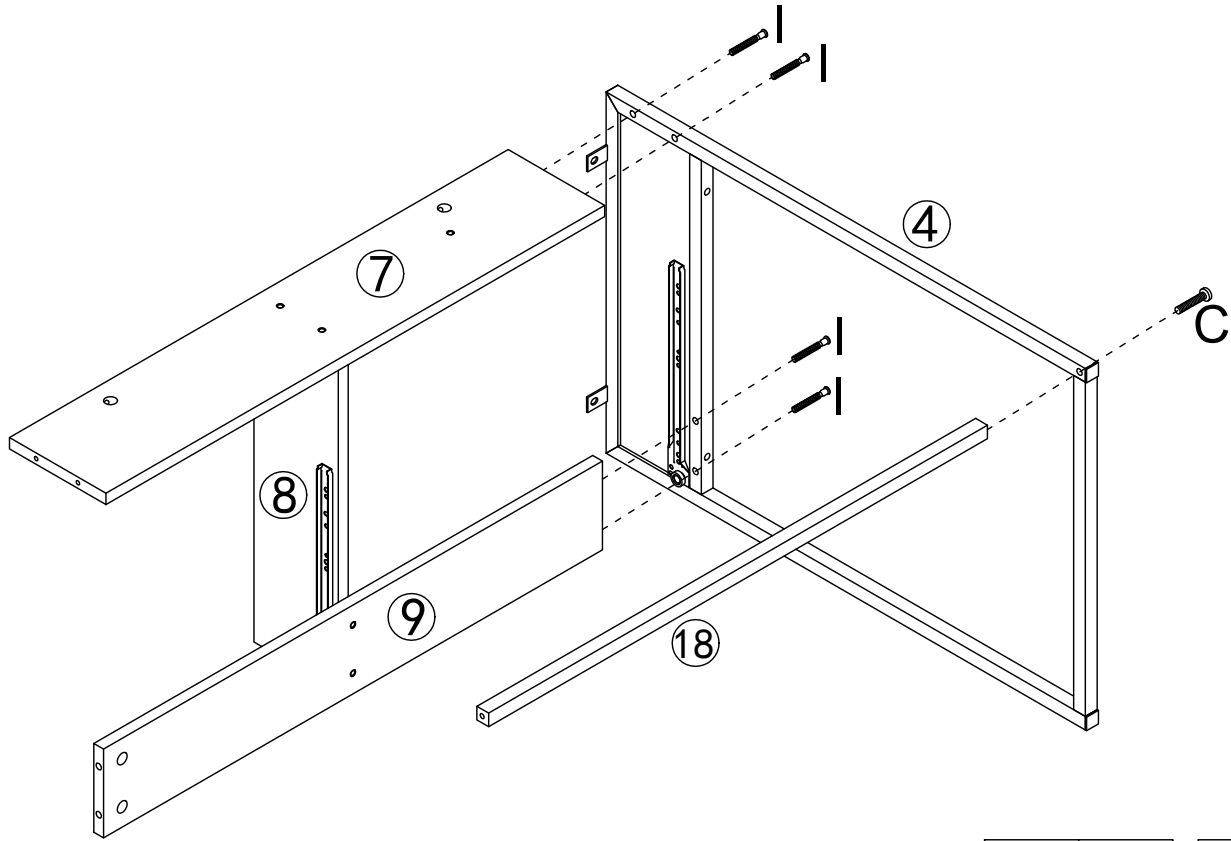



I	X4
	
M7x50mm	

C	X1
	
M6x40mm	

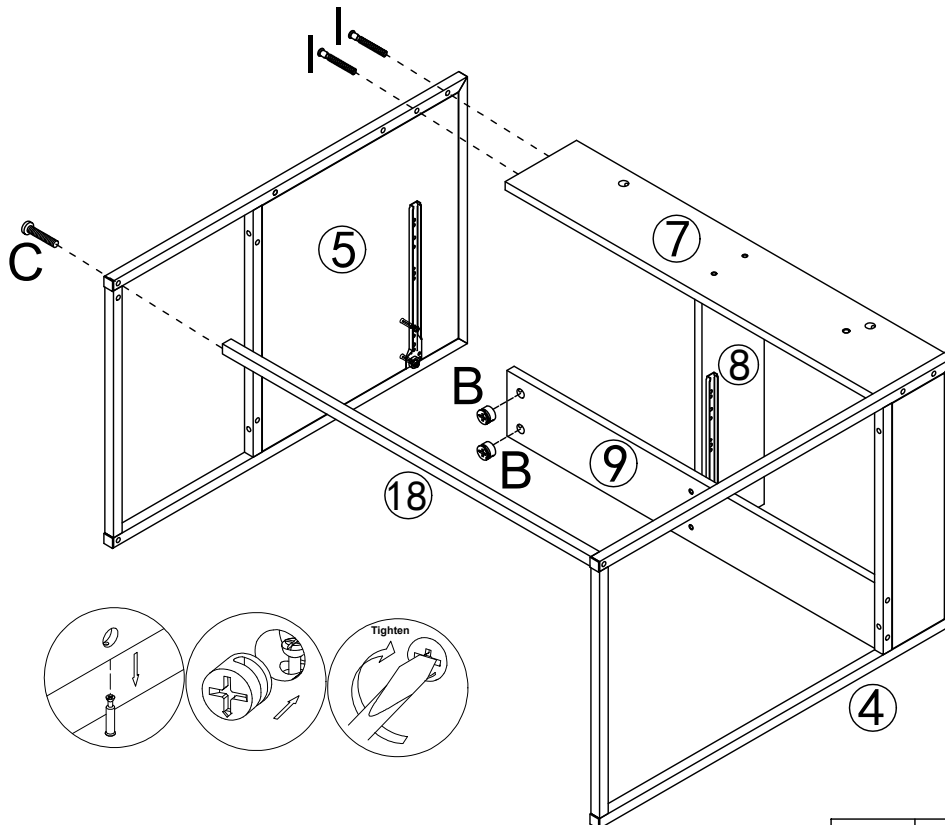
6

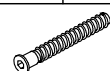



I	X2
	
M7x50mm	

B	X2
	
Ø15x9mm	

C	X1
	
M6x40mm	

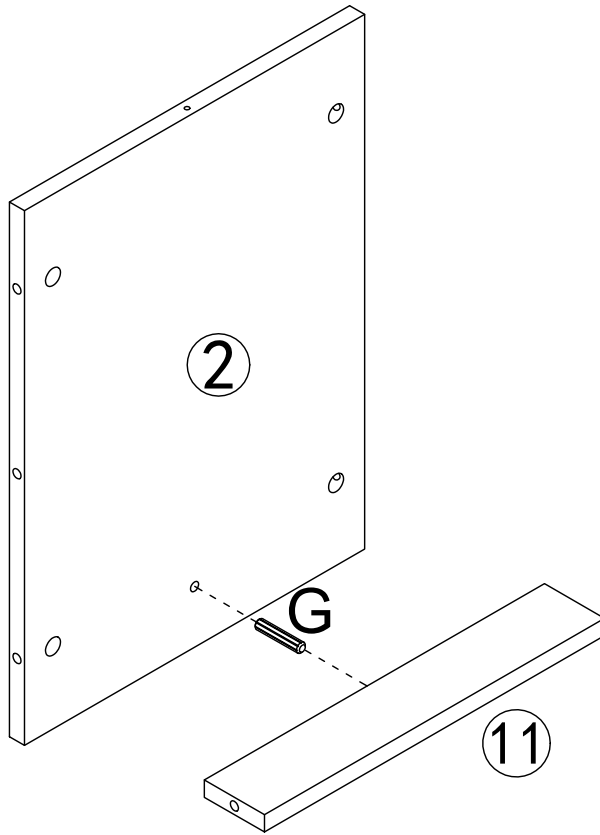
7



G	X1
	
Ø8x30mm	

8

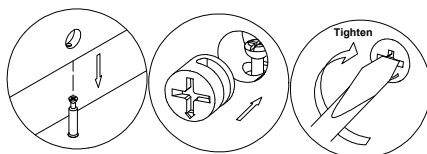
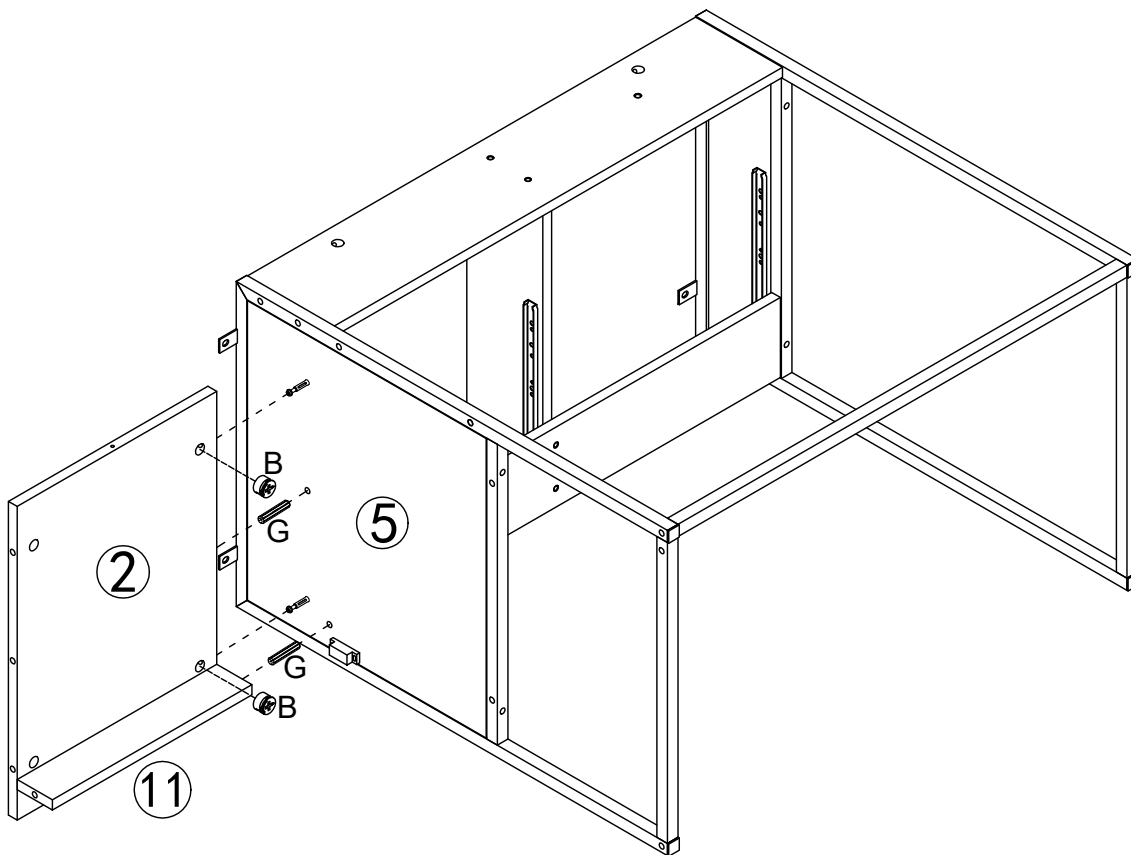



B	X2
	
Ø15x9mm	

G	X2
	
Ø8x30mm	

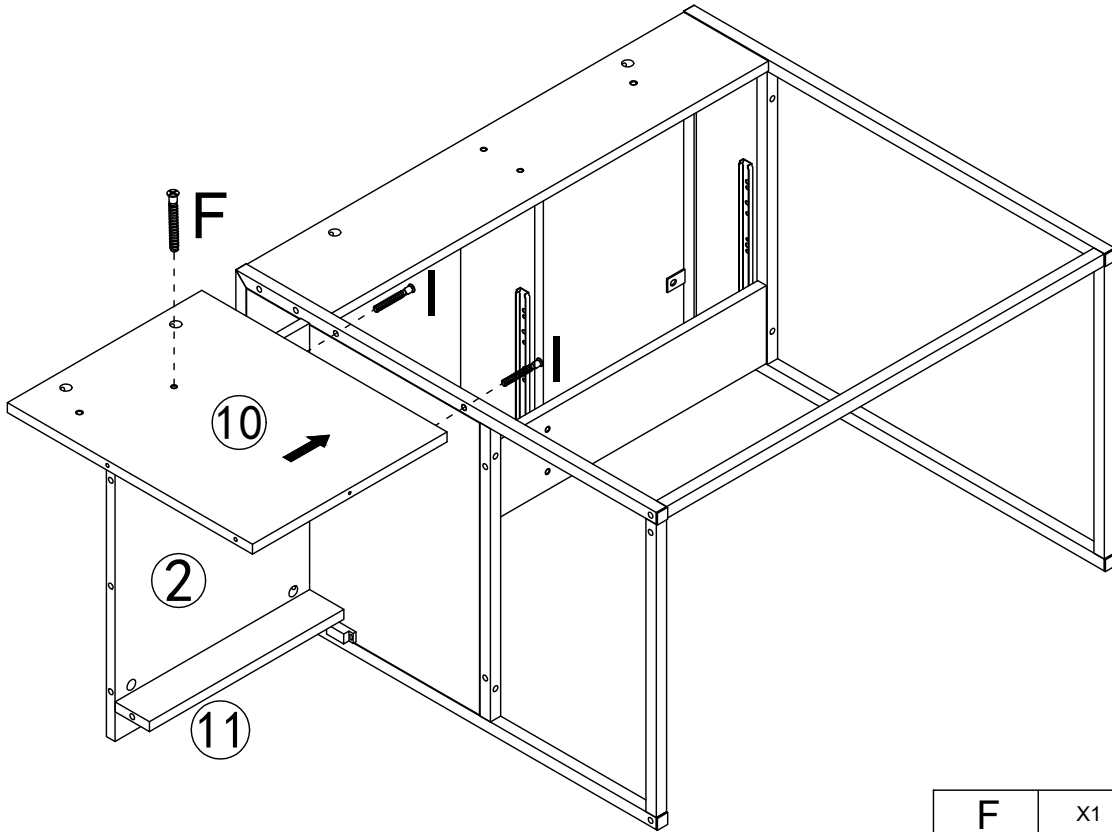

9

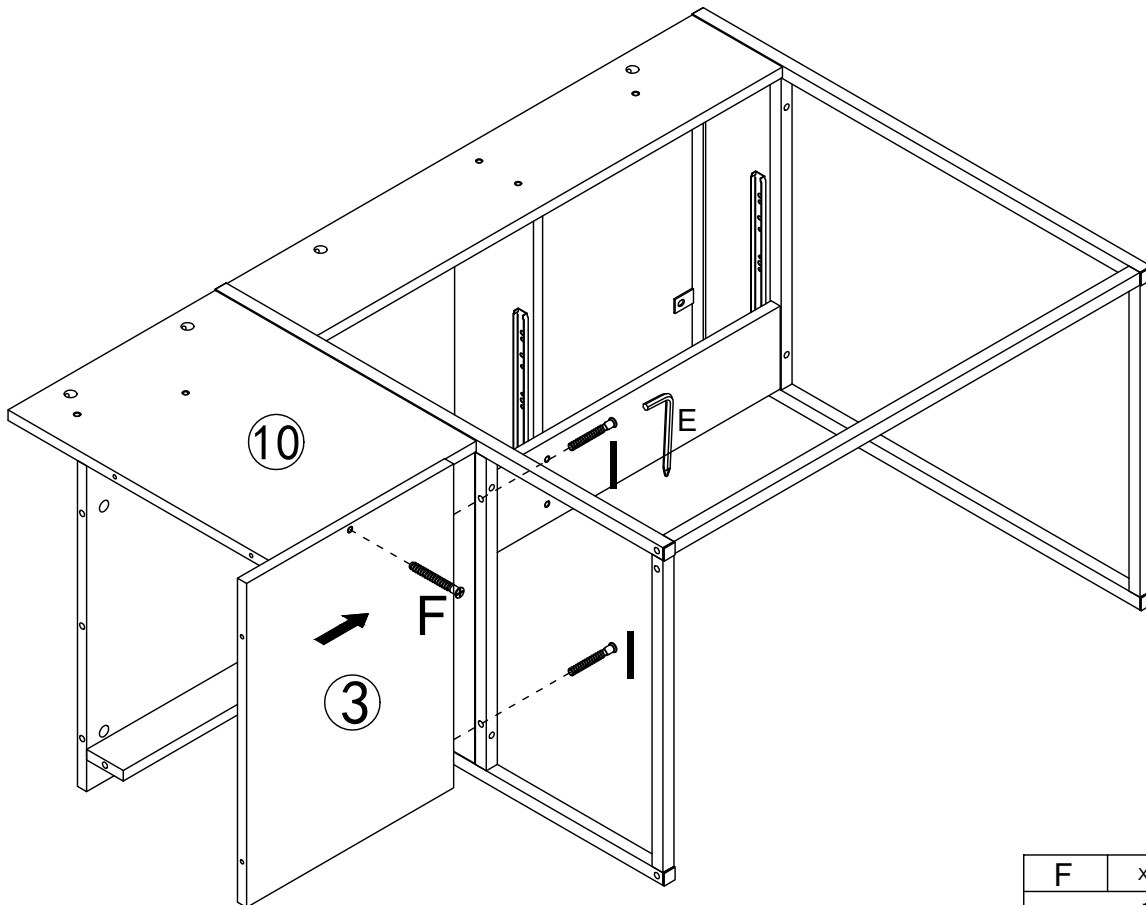

F	X1	I	X2
			
M5x40mm		M7x50mm	

10



F	X1	I	X2
			
M5x40mm		M7x50mm	

11

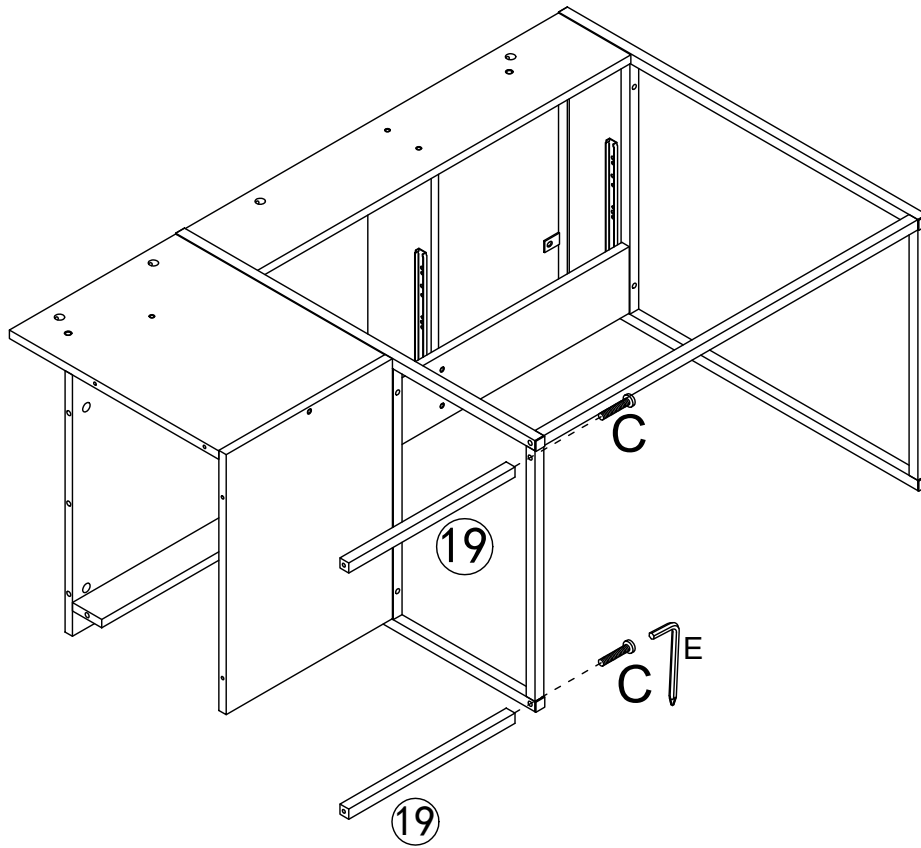

C	X2
M6x40mm	

12

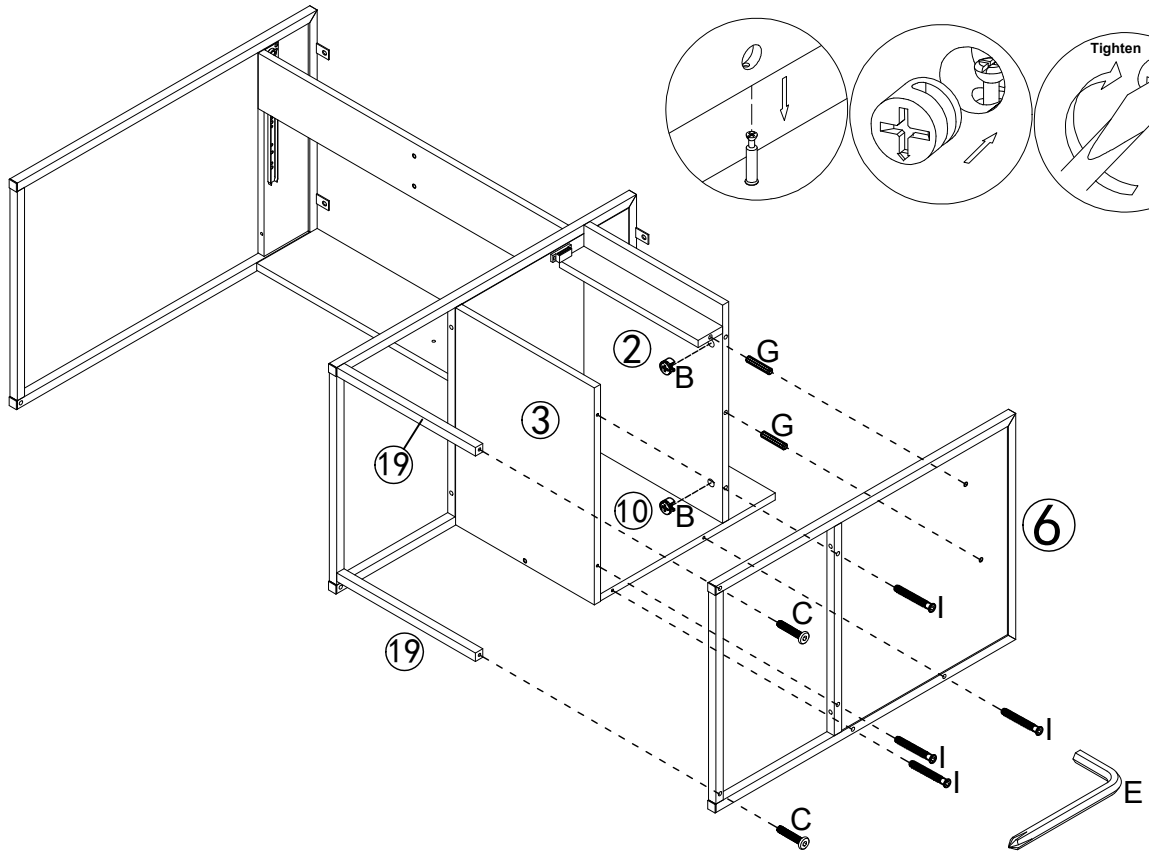

G	X2
Ø8x30mm	

B	X2
Ø15x9mm	

I	X4
M7x50mm	

C	X2
M6x40mm	

13

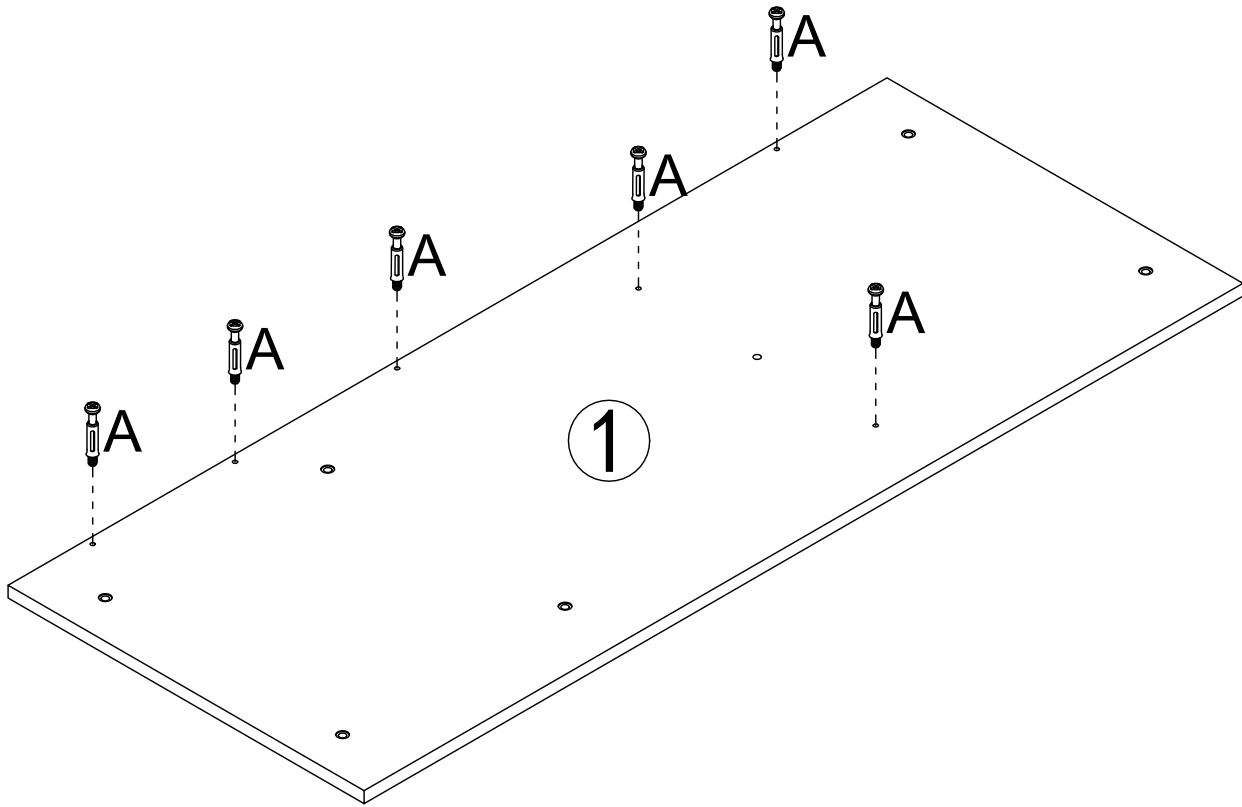

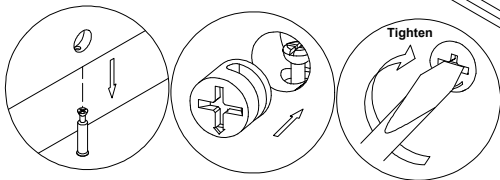
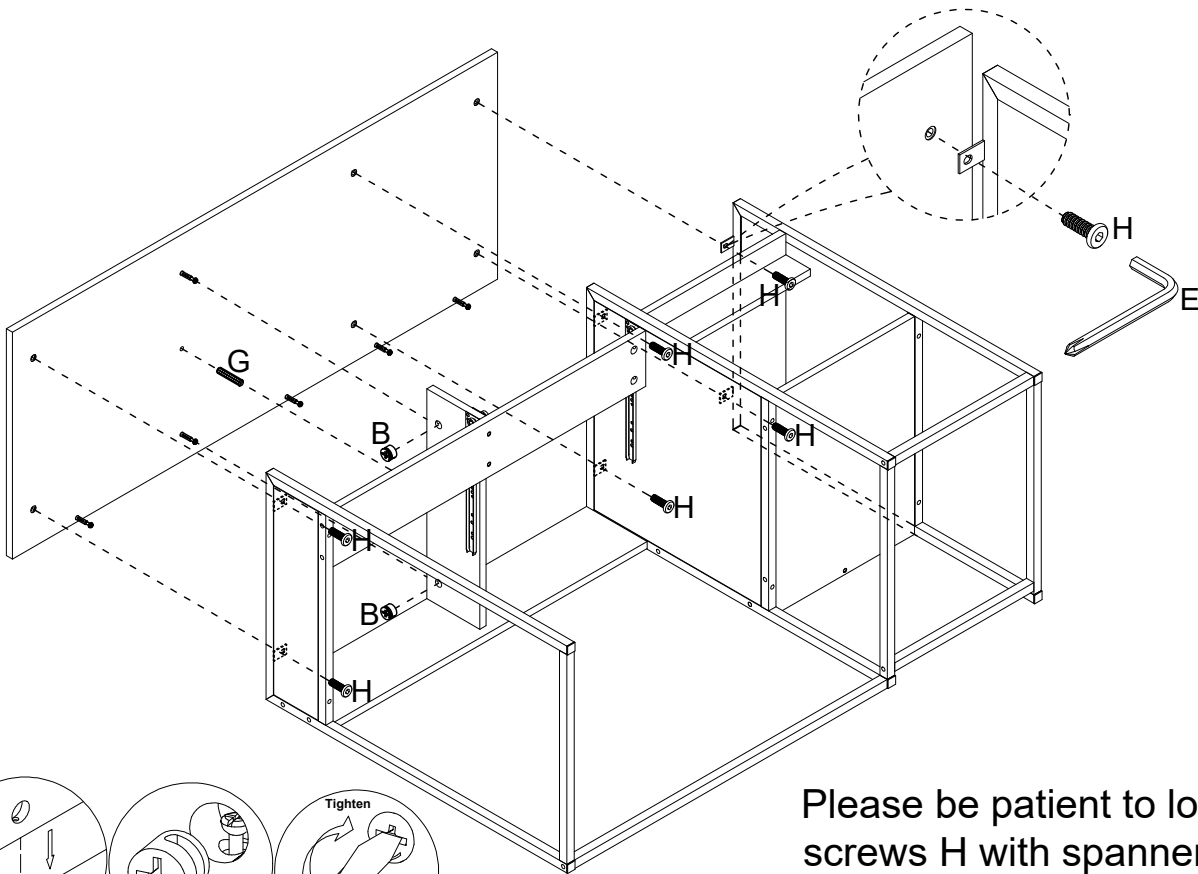

A	X6
	
M6x35mm	

14



Please be patient to lock hexagon screws H with spanner E.

B	X2	G	X1	H	X6
					
Ø15x9mm		Ø8x30mm		M6x12mm	

15

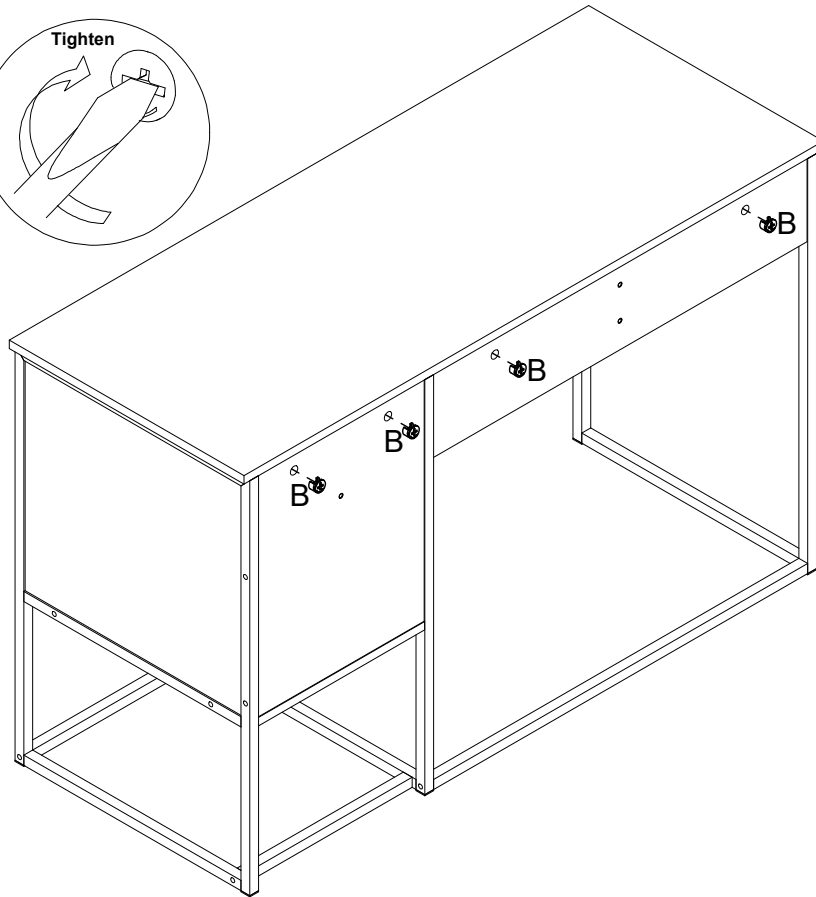
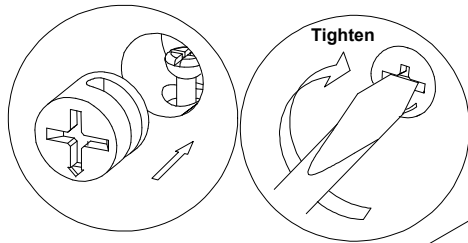

B	x4
Ø15x9mm	

16

Anti falling accessories for backup if necessary.

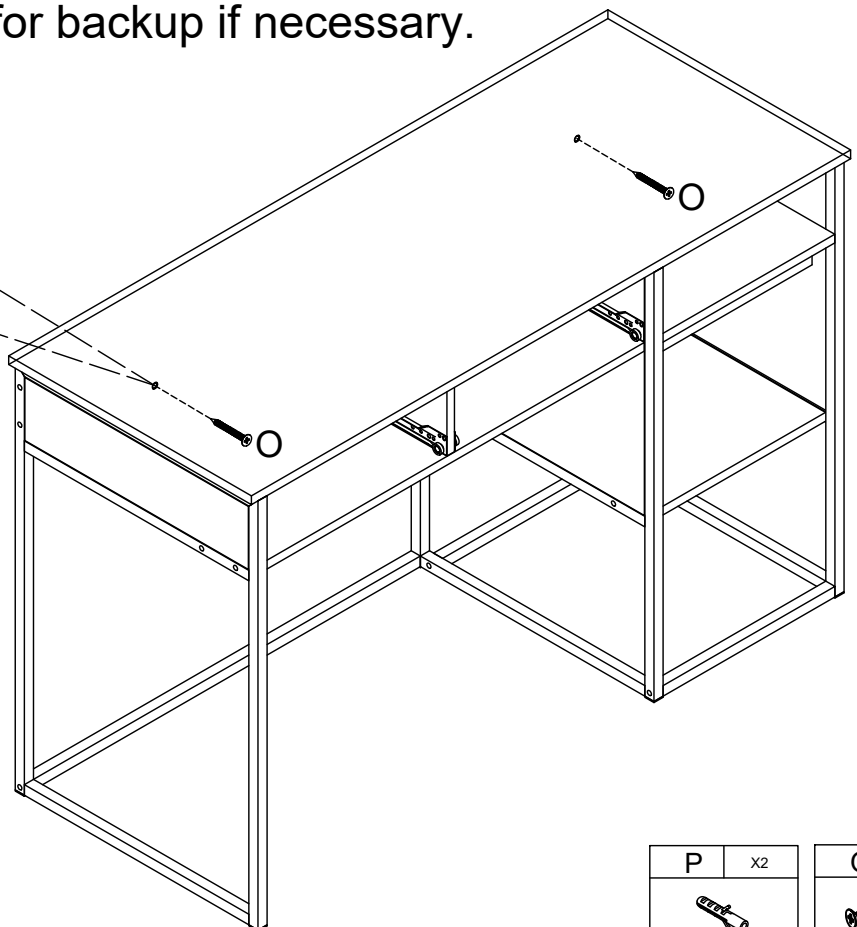
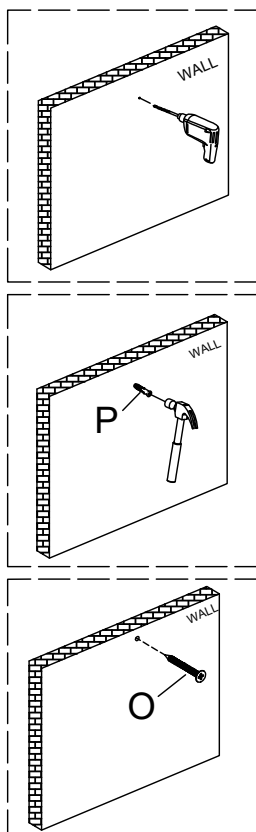



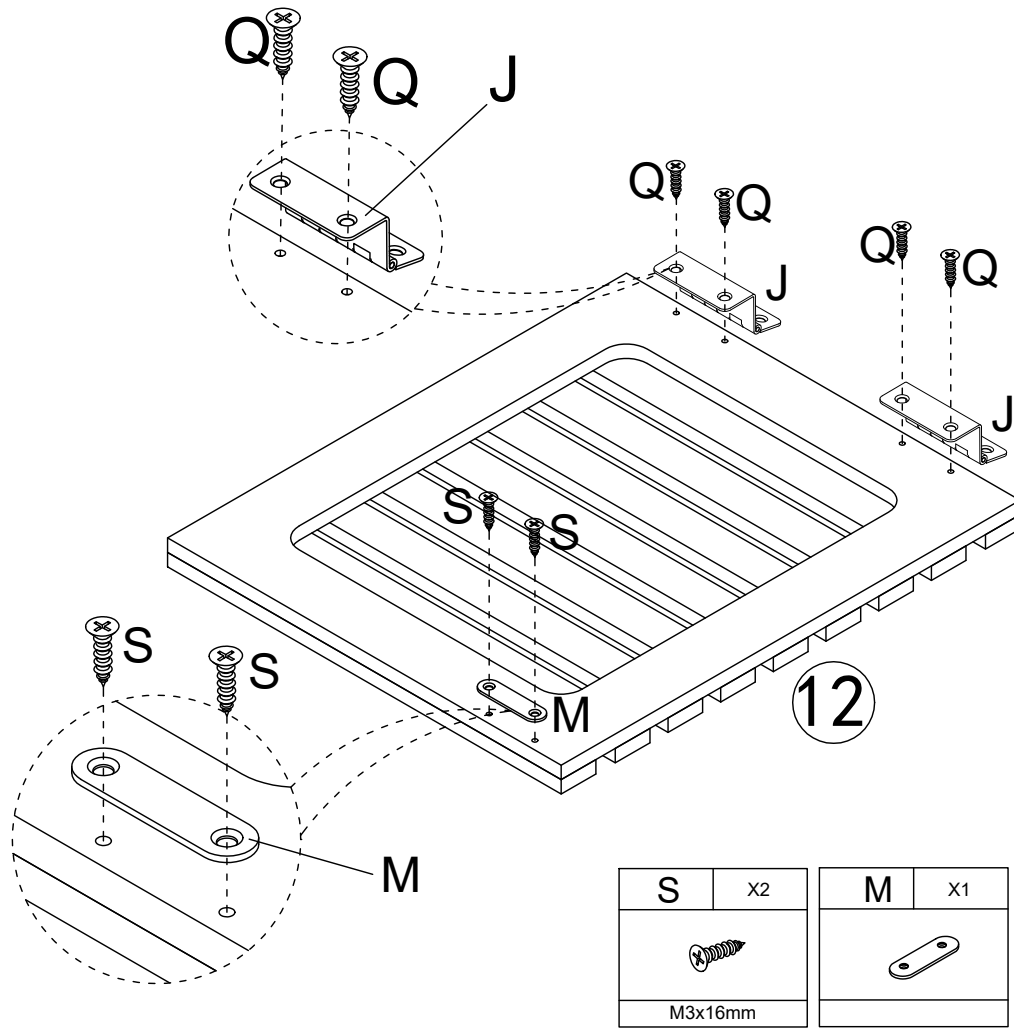

P	x2
Ø6x30mm	

O	x2
M4x50mm	

17



S	x2	M	x1	J	x2	Q	x4
							
M3x16mm						M3.5x14mm	

18

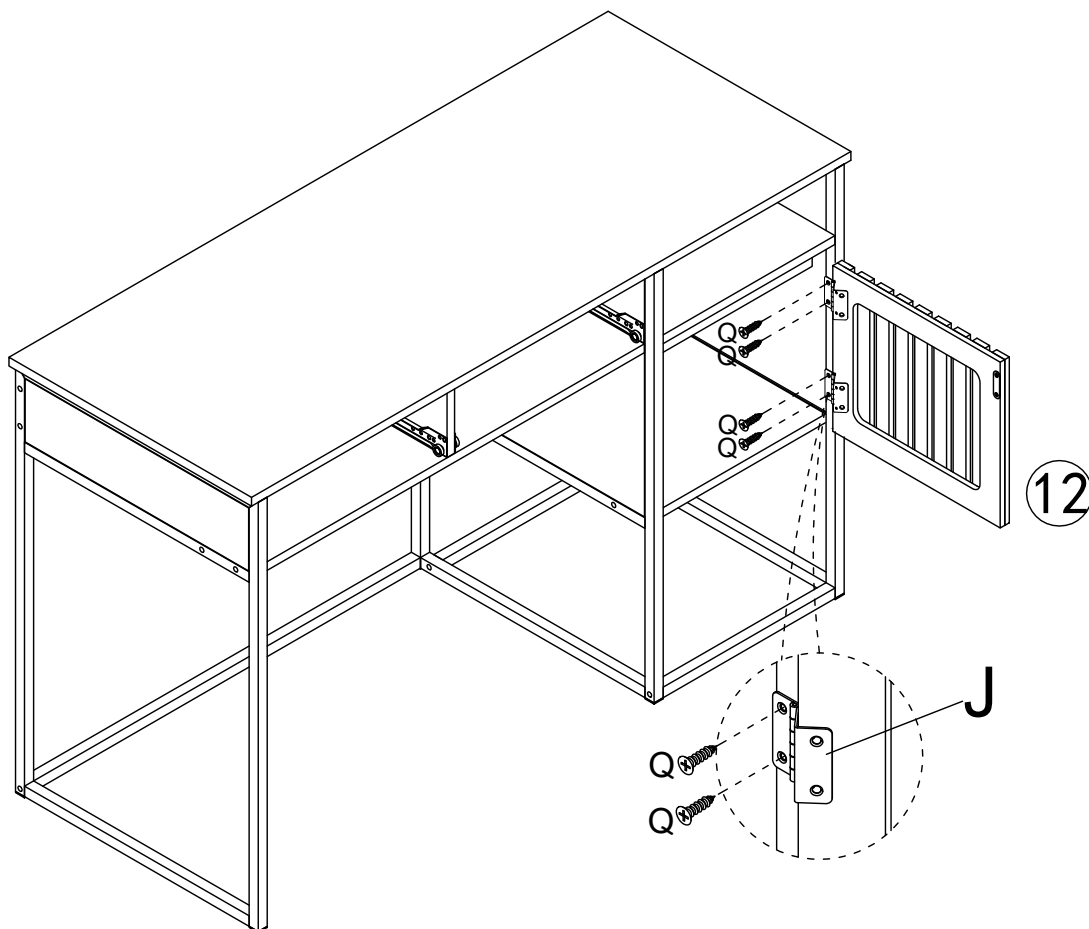

Q	x4
	
M3.5x14mm	

19

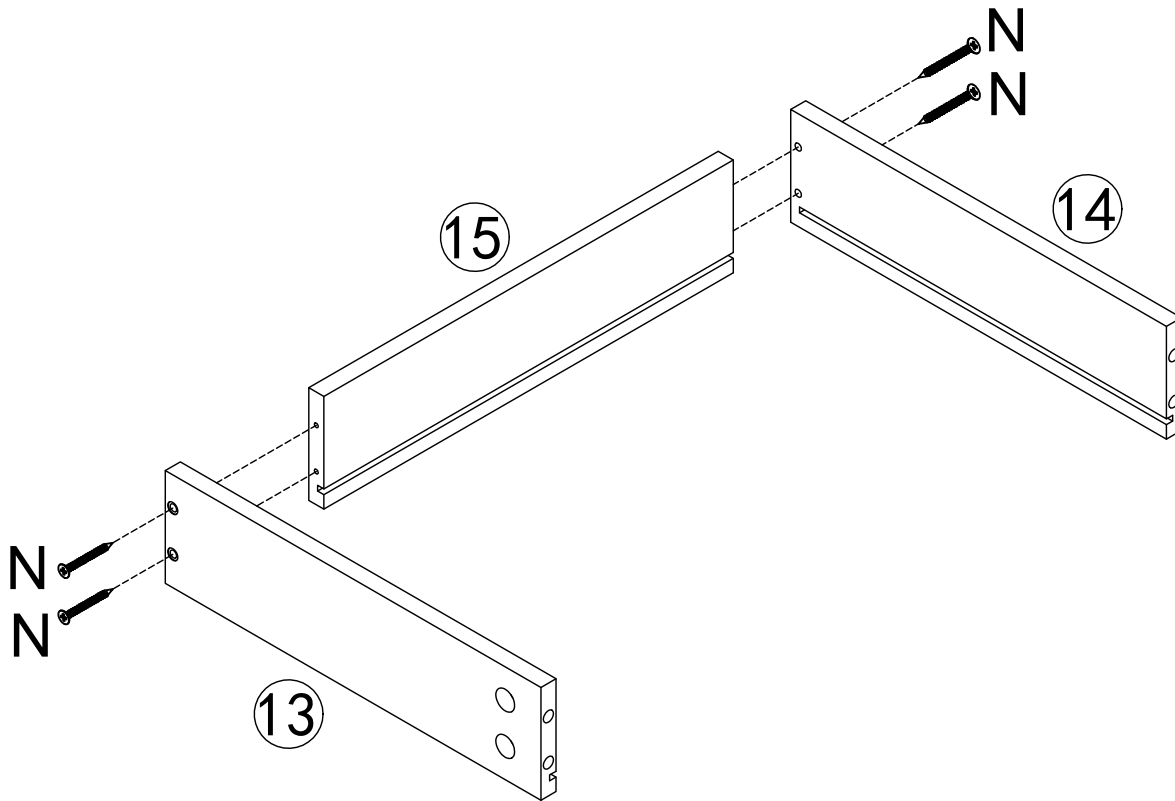

x2

N	x8
	
M4x35mm	

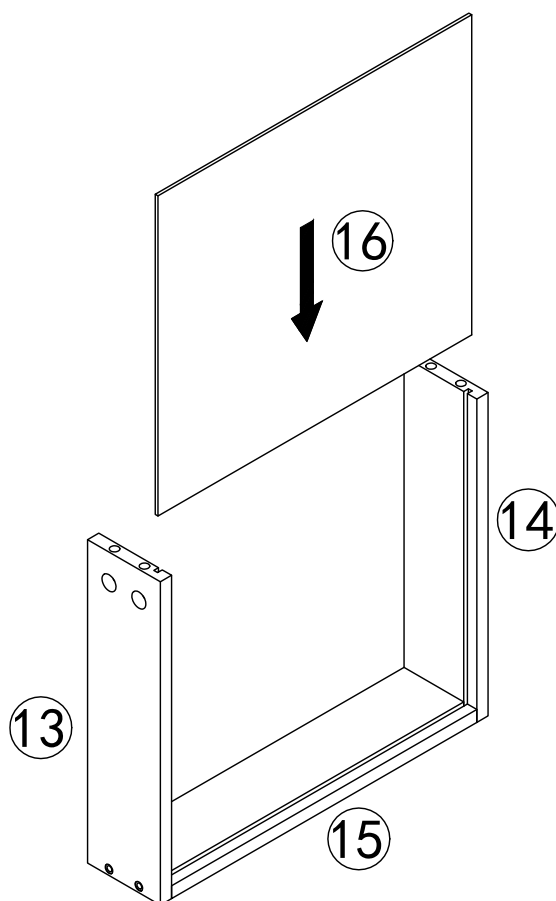

20

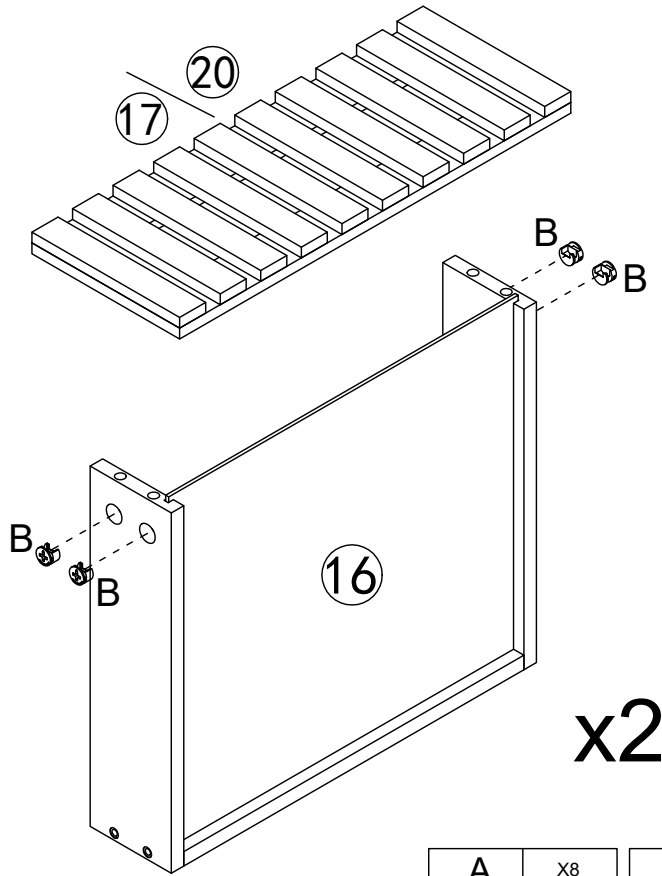
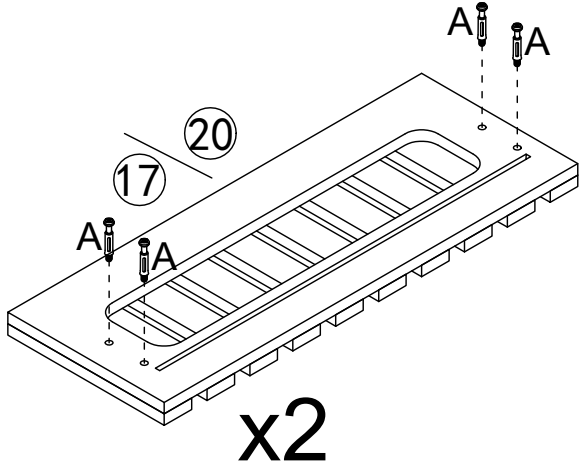
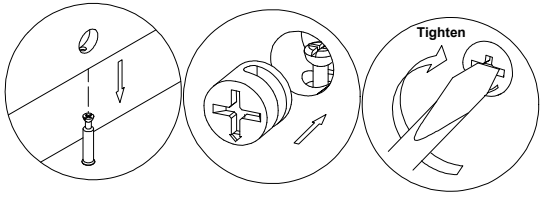

x2

21



A	x8	B	x8
			
M6x35mm		Ø15x9mm	

22

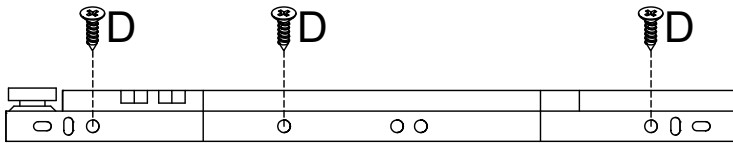

DL/DR

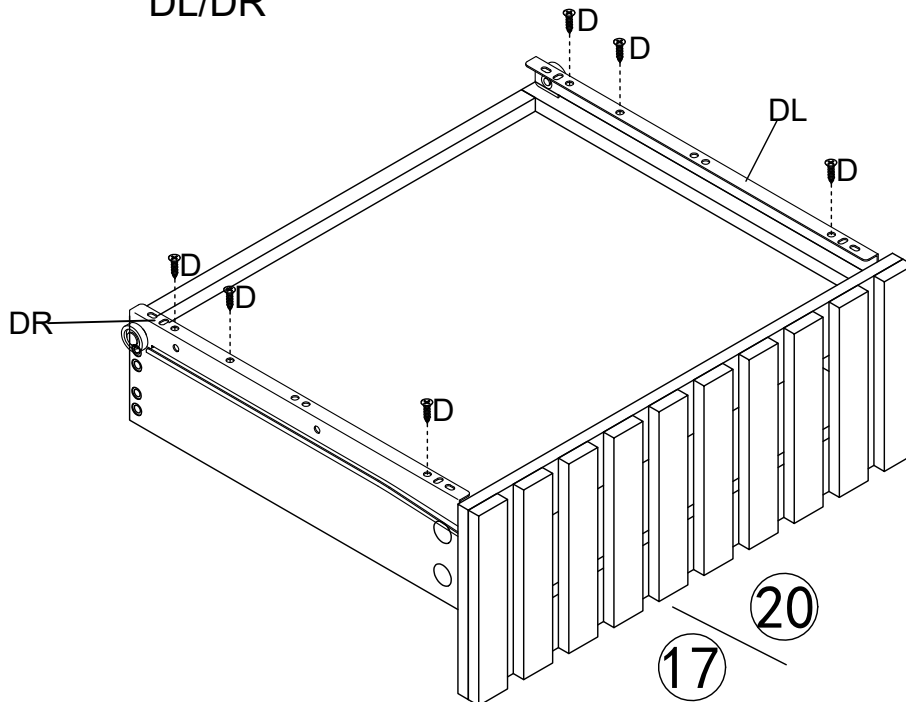

x2

D	x12
	
M3x14mm	

23

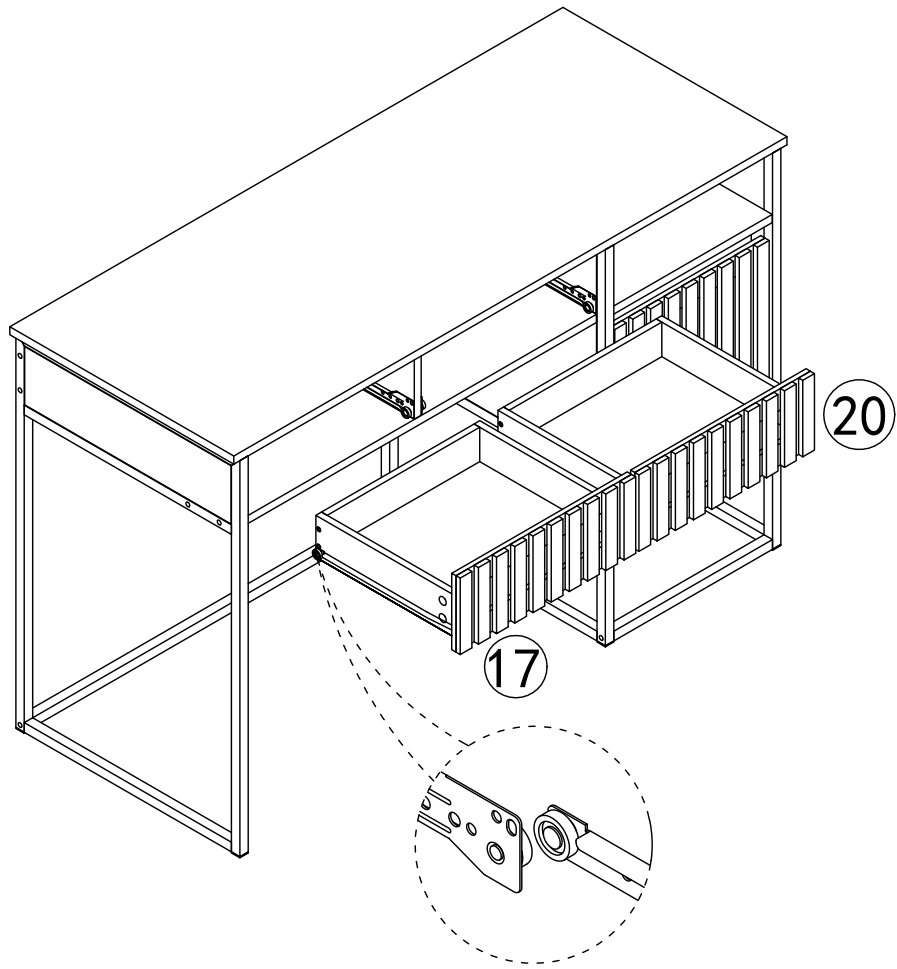

24

